



MURATORI

**TIPO-TYPE-TYP
MAS**

CATALOGO RICAMBI
Catalogue Pièces Detachées
Ersatzteilkatalog
Spare Parts Catalogue
Catálogo Recambios

EDIZIONE 02/1998



**NORME PER LE ORDINAZIONI - COMMANDES/NORMES - BESTELLNORMEN - HOW TO ORDER
INDICE DELLE TAVOLE - INDEX DES TABLES - TAFELVERZEICHNIS - TABLES INDEX**

MAS

Per ordinare parti di ricambio specificare:

- tipo e matricola della macchina (apposti sulla macchina o sui documenti di acquisto);
- numero del riferimento del pezzo nel disegno (Pos.), numero della tavola (Tav.) e numero di codice

N.B.: le indicazioni destro o sinistro vengono date guardando la macchina da dietro.

Pour les commandes de pièces de rechange veuillez spécifier:

- type et numéro de serie de la machine (indiqués sur la machine et sur le bon d'achat);
- numéro de référence du pièce sur le plan (Pos.), numéro du plan (Tav.) et numero de code (codice)

N.B.: les indications droite ou gauche sont données en regardant la machine par derrière.

Zum Bestellen von Ersatzteilen folgendes angeben:

- Typ und Serien-Nr. der Maschine (zu finden auf der Maschine oder der Einkaufspapieren);
- Bezug-Nr. des Ersatzteils auf der Zeichnung (Pos.), Zeichnungsnummer (Tav.) und Kodenummer (codice)

N.B.: Die Angaben rechts und links verstehen sich so, dass man hinter der Maschine steht.

When ordering spare parts specify:

- machine type and serial number (found on the machine or on the purchasing documents);
- reference number of the part on the relative drawing (Pos.), number of the drawing (Tav.) and part number (codice)

N.B.: right-hand or left-hand indications are made by viewing the machine from the rear.

TAV. 1.0
GRUPPO TELAIO
ENSEMBLE CHASSIS
SATZ FÜR RAHMEN
KIT FOR FRAME

TAV. 2.0
GRUPPO RULLO ROTORE STANDARD A 4 ZAPPE
ENSEMBLE ROTOR STANDARD A 4 LAMES
SATZ FÜR STANDARDROTOR ZU 4 MESSER
KIT FOR STANDARD ROTOR 4 BLADES

TAV. 3.0
GRUPPO RIDUTTORE A 1 VELOCITA'
ENSEMBLE BOITIER MONOVITNESS
SATZ FÜR EINGANGGETRIEBE
KIT FOR ONE-SPEED GEAR BOX

TAV. 4.0
GRUPPO RIDUTTORE A 1 VELOCITA' (fino a matr. 32189)
ENSEMBLE BOITIER MONOVITESSE (jusqu'au nr. de serie 32189)
SATZ FÜR EINGANGGETRIEBE (bis Seriennr. 32189)
KIT FOR ONE-SPEED GEAR BOX (up to serial nr. 32189)

TAV. 5.0
PROTEZIONI ANTINFORTUNISTICHE "CE"
PROTECTIONS "CE"
UNFALLSCHUTZVORRICHTUNGEN "CE"
SAFETY GUARDS "CE"

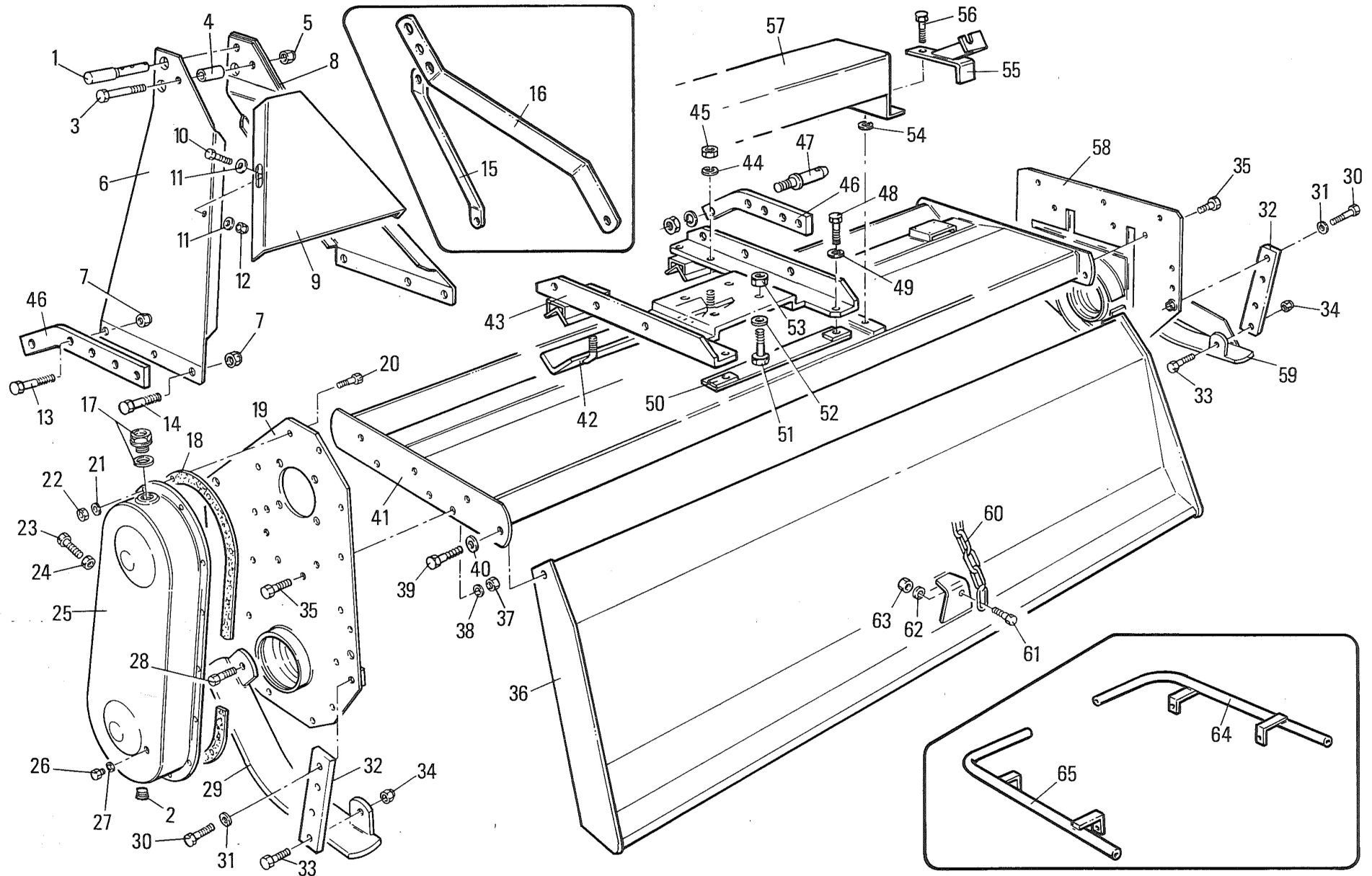

MURATORI MAS

TAV. 1.0

POS.	N°	CODICE Q.	DESCRIZIONE	DESIGNATION	BENENNUNG	DESCRIPTION	DESIGNAZIONE	Da matr.	Fino matr.
								De nr. serie Vom Seriennr. From serial nr.	Jusqu'au nr. serie Bis Seriennr. Up to serial nr.
1	68062000	1	PERNO	AXE	BOLZEN	PIN	1^CAT.		
2	68008700	1	TAPPO	BOUCHON	STOPFEN	PLUG	3/8" CONICO		
3	60021500	1	VITE	VIS	SCHRAUBE	SCREW	TE 12x80 UNI 5737 ZNT 8.8		
4	32069101	1	DISTANZIALE	ENTRETOISE	DISTANZSTUECK	SPACER			
5	62010600	1	DADO	ECROU	MUTTER	NUT	M 12 x 1,75 AUTOBLOCC.		
6	40089400	1	ARCATA SX	ARCADE (G)	ARKADE (LINKS)	ARCADE (LH)		25602	
7	62010600	6	DADO	ECROU	MUTTER	NUT	M 12 x 1,75 AUTOBLOCC.	25602	
8	40089300	1	ARCATA DX	ARCADE (D)	ARKADE (RECHTS)	ARCADE (RH)		25602	
9	39097900	1	CHIUSURA	FERMATURE	VERSCHLUSS	LOCK		25602	
10	60022800	2	VITE	VIS	SCHRAUBE	SCREW	TE 8 x 20 UNI 5739 ZNT 8.8	25602	
11	61004700	4	RONDELLA	RONDELLE	SCHEIBE	WASHER	PIANAØ 8 UNI 6592 ZNT	25602	
12	62007200	2	DADO	ECROU	MUTTER	NUT	M 8 x 1,25 UNI 5587 ZNT 8.8	25602	
13	60028100	4	VITE	VIS	SCHRAUBE	SCREW	TE 12 x 55UNI 5737 ZNT 8.8		
14	60023000	2	VITE	VIS	SCHRAUBE	SCREW	TE 12 x 30 UNI 5739 ZNT 8.8		
15	30056200	2	TIRANTE	TIRANT	STANGE	TIEROD			25601
16	30056100	2	TIRANTE	TIRANT	STANGE	TIEROD			25601
17	68000500	1	TAPPO	BOUCHON	STOPFEN	PLUG			
18	80005601	1	GUARNIZIONE	GARNITURE	DICHTUNG	SEAL			
19	40042301	1	PIASTRA	PLAQUE	PLATTE	PLATE			23432
19	40086001	1	PIASTRA	PLAQUE	PLATTE	PLATE		23433	
20	60000900	9	VITE	VIS	SCHRAUBE	SCREW	TE 8 x 20 UNI 5739 8.8		
20	60023800	1	VITE	VIS	SCHRAUBE	SCREW	TE 8 x 50 UNI 5737 8.8		
21	61000600	10	RONDELLA	RONDELLE	SCHEIBE	WASHER	DENT. INT. Ø 8 UNI 3704		
22	62000700	10	DADO	ECROU	MUTTER	NUT	M 8 x 1,25 UNI 5587		
23	60027400	1	VITE	VIS	SCHRAUBE	SCREW	TE 14 x 70 UNI 5739 8.8		
24	62000100	1	DADO	ECROU	MUTTER	NUT	M 14 x 2 ALTO UNI 5587		

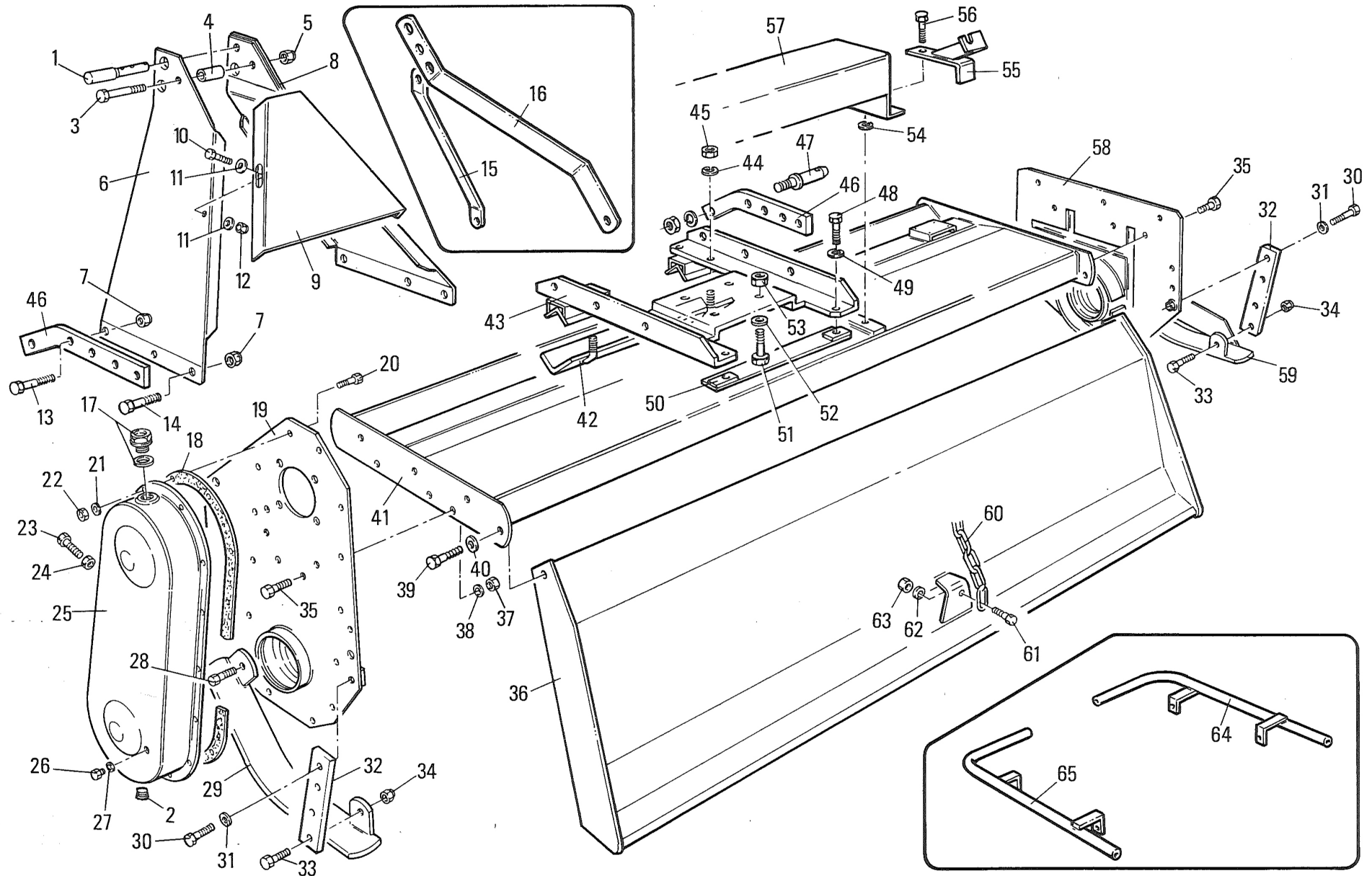

MURATORI MAS

TAV. 1.0

POS.	N°	CODICE Q.	DESCRIZIONE	DESIGNATION	BENENNUNG	DESCRIPTION	DESIGNAZIONE	Da matr.	Fino matr.
								De nr. serie Vom Seriennr. From serial nr.	Jusqu'au nr. serie Bis Seriennr. Up to serial nr.
25	40010700	1	COPERCHIO	COUVERCLE	DECKEL	COVER			
26	60001100	1	VITE	VIS	SCHRAUBE	SCREW	TE 10 x 10 UNI 5739 4.8		
27	61000800	1	RONDELLA	RONDELLE	SCHEIBE	WASHER	PIANA Ø 10 ALLUMINIO		
28	60002200	2	VITE	VIS	SCHRAUBE	SCREW	TE 12 x 20 UNI 5739 8.8		
29	40002501	1	SLITTA SX	PATIN (G)	STUTZTKUFE (LINKS)	SKID (LH)			
30	60001400	2	VITE	VIS	SCHRAUBE	SCREW	TE 12 x 25 UNI 5739 8.8		
31	61000500	2	RONDELLA	RONDELLE	SCHEIBE	WASHER	DENT. INT. Ø 12 UNI 3704		
32	30001300	2	ASTA REGOLAZIONE	TIGE REGOLATION	TIEFEINSTELLUNGSSTANG	DEPHT CONTROL ROD			
33	60001400	2	VITE	VIS	SCHRAUBE	SCREW	TE 12 x 25 UNI 5739 8.8		
34	62001100	2	DADO	ECROU	MUTTER	NUT	M 12 x 1,75 UNI 5589		
35	60002300	12	VITE	VIS	SCHRAUBE	SCREW	TE 10 x 25 UNI 5739 8.8		
36	41008002	1	COFANO	CAPOT	SCHUTZHAUBE	HOOD	MA 085	18074	
36	41008102	1	COFANO	CAPOT	SCHUTZHAUBE	HOOD	MA 105	18074	
36	41022402	1	COFANO	CAPOT	SCHUTZHAUBE	HOOD	MA 115	18074	
36	41008202	1	COFANO	CAPOT	SCHUTZHAUBE	HOOD	MA 125	18074	
36	41022502	1	COFANO	CAPOT	SCHUTZHAUBE	HOOD	MA 135	18074	
36	41008302	1	COFANO	CAPOT	SCHUTZHAUBE	HOOD	MA 145	18074	
36	41051801	1	COFANO	CAPOT	SCHUTZHAUBE	HOOD	MA 085	18075	
36	41051901	1	COFANO	CAPOT	SCHUTZHAUBE	HOOD	MA 105	18075	
36	41052001	1	COFANO	CAPOT	SCHUTZHAUBE	HOOD	MA 115	18075	
36	41052101	1	COFANO	CAPOT	SCHUTZHAUBE	HOOD	MA 125	18075	
36	41052201	1	COFANO	CAPOT	SCHUTZHAUBE	HOOD	MA 135	18075	
36	41052301	1	COFANO	CAPOT	SCHUTZHAUBE	HOOD	MA 145	18075	
37	62000500	12	DADO	ECROU	MUTTER	NUT	M 10 x 1,5 UNI 5587		
38	61000400	12	RONDELLA	RONDELLE	SCHEIBE	WASHER	DENT. INT. Ø 10 UNI 3704		
39	60019300	2	VITE	VIS	SCHRAUBE	SCREW	TE 14 x 50 UNI 5739 8.8	18075	

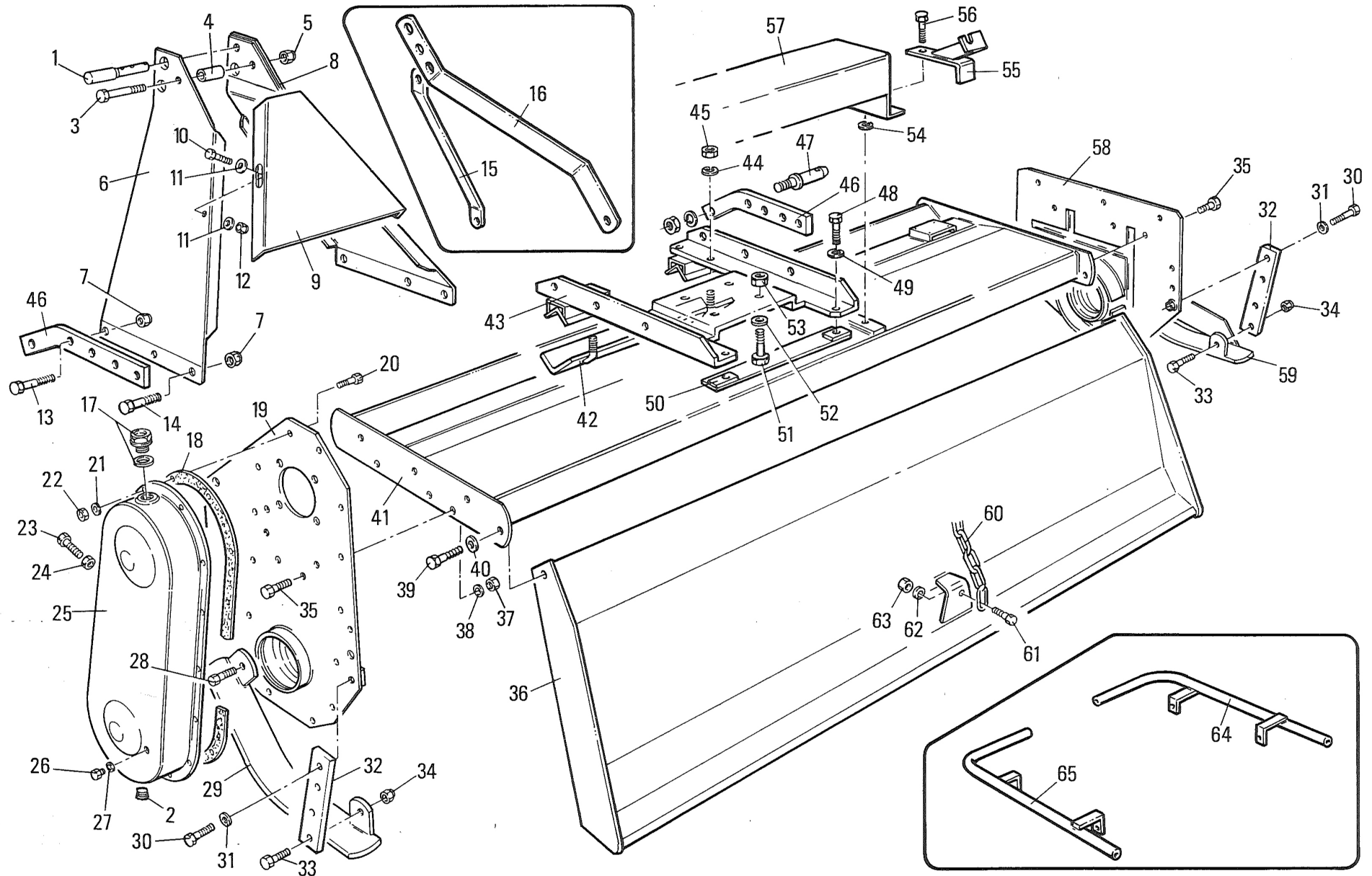

MURATORI MAS

TAV. 1.0

POS.	N°	CODICE Q.	DESCRIZIONE	DESIGNATION	BENENNUNG	DESCRIPTION	DESIGNAZIONE	Da matr.	Fino matr.
								De nr. serie Vom Seriennr. From serial nr.	Jusqu'au nr. serie Bis Seriennr. Up to serial nr.
40	61004500	2	RONDELLA	RONDELLE	SCHEIBE	WASHER	GROWER Ø 14 UNI 1751	18075	
41	41050700	1	TELAIO	CHASSIS	RAHMEN	FRAME	MAS 085		
41	41050800	1	TELAIO	CHASSIS	RAHMEN	FRAME	MAS 105		
41	41050900	1	TELAIO	CHASSIS	RAHMEN	FRAME	MAS 115		
41	41051000	1	TELAIO	CHASSIS	RAHMEN	FRAME	MAS 125		
41	41051100	1	TELAIO	CHASSIS	RAHMEN	FRAME	MAS 135		
41	41051200	1	TELAIO	CHASSIS	RAHMEN	FRAME	MAS 145		
42	40070000	1	RISCONTRO	BARRE ANTER. DE FIXAG	VORDERES HALTEBAND	FRONT CLAMP BAR			
43	40068600	1	CASTELLO SCORR.	SYSTEME DEPORTABLE	GLEITENSCHLOSS	SYSTEME DEPORTABLE			32189
43	40106900	1	CASTELLO SCORR.	SYSTEME DEPORTABLE	GLEITENSCHLOSS	SYSTEME DEPORTABLE		32190	
44	61000500	4	RONDELLA	RONDELLE	SCHEIBE	WASHER	DENT. INT. Ø 12 UNI 3704		
45	62000600	4	DADO	ECROU	MUTTER	NUT	M 12 x 1,75 UNI 5587		
46	30055901	2	BRACCIO MOBILE	BRAS	ARM	ARM			
46	40086400	1	BRACCIO MOBILE SX	BRAS	ARM	ARM	ATTACCO 26"		
46	40086500	1	BRACCIO MOBILE DX	BRAS	ARM	ARM	ATTACCO 26"		
47	68062500	2	PERNO	AXE	BOLZEN	PIN			
48	60001400	2	VITE	VIS	SCHRAUBE	SCREW	TE 12 x 25 UNI 5739 8.8		
49	61000500	2	RONDELLA	RONDELLE	SCHEIBE	WASHER	DENT. INT. Ø 12 UNI 3704		
50	40068500	1	PIATTO	PLAQUE	PLATTE	DISC			
51	60025600	4	VITE	VIS	SCHRAUBE	SCREW	TE 10 x 130 UNI 5737 ZNT 8.8	32190	
51	60002200	4	VITE	VIS	SCHRAUBE	SCREW	TE 12 x 20 UNI 5739 8.8		32189
52	61004900	4	RONDELLA	RONDELLE	SCHEIBE	WASHER	PIANA Ø 10 UNI 6592 ZNT	32190	
52	61000500	4	RONDELLA	RONDELLE	SCHEIBE	WASHER	DENT. INT. Ø 12 UNI 3704		32189
53	62010400	4	DADO	ECROU	MUTTER	NUT	M 10 x 1,5 AUTOBLOCC.	32190	
54	61000400	1	RONDELLA	RONDELLE	SCHEIBE	WASHER	DENT. INT. Ø 10 UNI 3704		
55	40068400	1	AGGANCIAMENTO CATENA	CROCHET	HAKEN	HOOK			

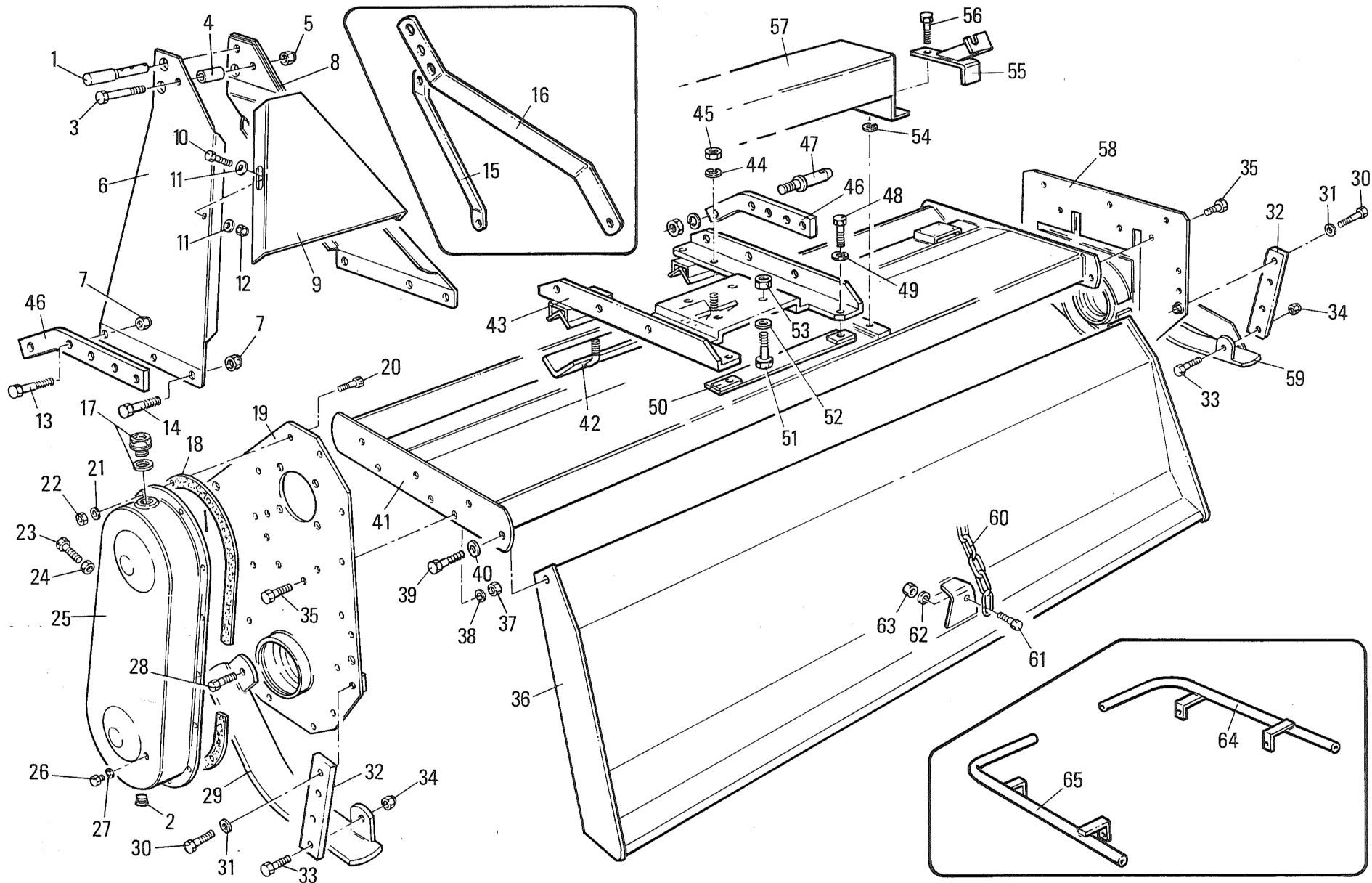

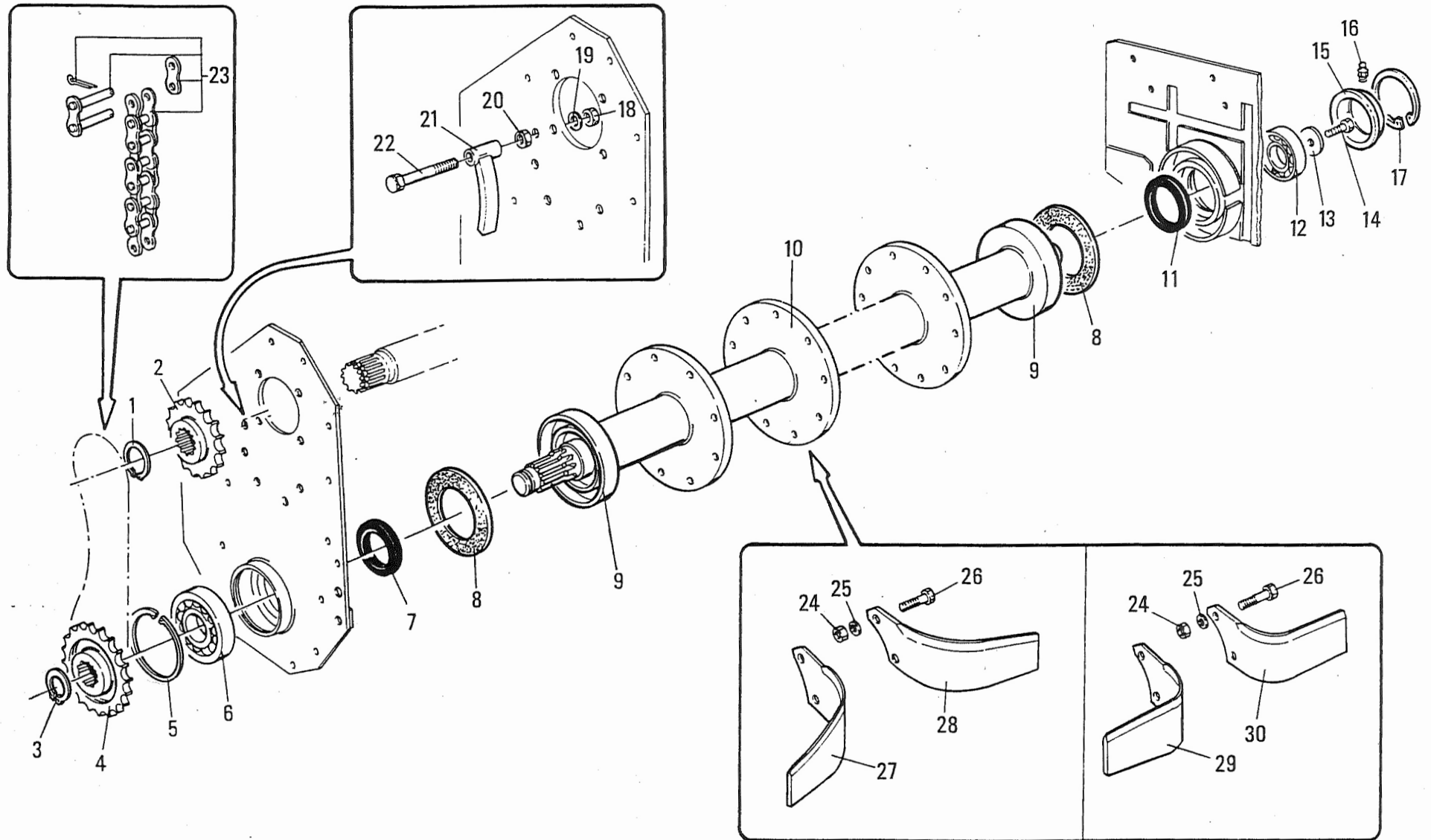

MURATORI MAS

TAV. 2.0

POS.	N°	CODICE Q.	DESCRIZIONE	DESIGNATION	BENENNUNG	DESCRIPTION	DESIGNAZIONE	Da matr.	Fino matr.
								De nr. serie Vom Seriennr. From serial nr.	Jusqu'au nr. serie Bis Seriennr. Up to serial nr.
1	63000700	1	ANELLO ELASTICO	ARREOTIR	SPANNRING	SNAP-RING	Ø 40 E UNI 7435		
2	10012600	1	PIGNONE	PIGNON	RITZEL	PINION	Z 10 1"		
2	10023800	1	PIGNONE SPECIALE	PIGNON SPECIAL	SONDER RITZEL	SPECIAL PINION	Z 11 1" giri maggiorati		
3	63000700	1	ANELLO ELASTICO	ARREOTIR	SPANNRING	SNAP-RING	Ø 40 E UNI 7435		
4	10006600	1	CORONA	COURONNE	KRANZ	CROWN	Z 17 1"		
4	10021400	1	CORONA SPECIALE	COURONNE SPECIAL	SONDER KRANZ	SPECIAL CROWN	Z 16 1" giri maggiorati		
5	63000200	1	ANELLO ELASTICO	ARREOTIR	SPANNRING	SNAP-RING	Ø 80 I UNI 7437		
6	67004400	1	CUSCINETTO	ROULEMENT	LAGER	BEARING	6208		
7	66002100	1	ANELLO TENUTA	JOINT D'ETANCHEITE	DICHTUNGSRING	JUNT RING	45x72x10		
8	68000600	2	GUARNIZIONE	GARNITURE	DICHTUNG	SEAL	Ø 100		
9	39049200	2	CAPPELOTTO	BOUCHON	ABSCHLUSSKAPPE	CAP NUT			
10	42013903	1	ROTORE	ROTOR	ROTOR	ROTOR	MA 85		
10	42014003	1	ROTORE	ROTOR	ROTOR	ROTOR	MA 105		
10	42014103	1	ROTORE	ROTOR	ROTOR	ROTOR	MA 115		
10	42014203	1	ROTORE	ROTOR	ROTOR	ROTOR	MA 125		
10	42014303	1	ROTORE	ROTOR	ROTOR	ROTOR	MA 135		
10	42014403	1	ROTORE	ROTOR	ROTOR	ROTOR	MA 145		
11	66000100	1	ANELLO TENUTA	JOINT D'ETANCHEITE	DICHTUNGSRING	JUNT RING	45x65x10		
12	67009700	1	CUSCINETTO	ROULEMENT	LAGER	BEARING	6306		
13	61002300	1	RONDELLA	RONDELLE	SCHEIBE	WASHER	Piana 13x40x4		
14	60001400	1	VITE	VIS	SCHRAUBE	SCREW	TE 12x25 UNI 5739 8,8		
15	39014000	1	COPERCHIO	COUVERCLE	DECKEL	COVER			
16	64000200	1	INGRASSATORE	GRAISSEUR	SCHMIERNIPPEL	GREASE FITTING	6x1 diritto		
17	63000300	1	ANELLO ELASTICO	ARREOTIR	SPANNRING	SNAP-RING	Ø 72 I UNI 7437		
18	62000600	1	DADO	ECROU	MUTTER	NUT	M 12x1,75 UNI 5587		
19	61000500	1	RONDELLA	RONDELLE	SCHEIBE	WASHER	Dent. int. Ø 12 UNI 3704		

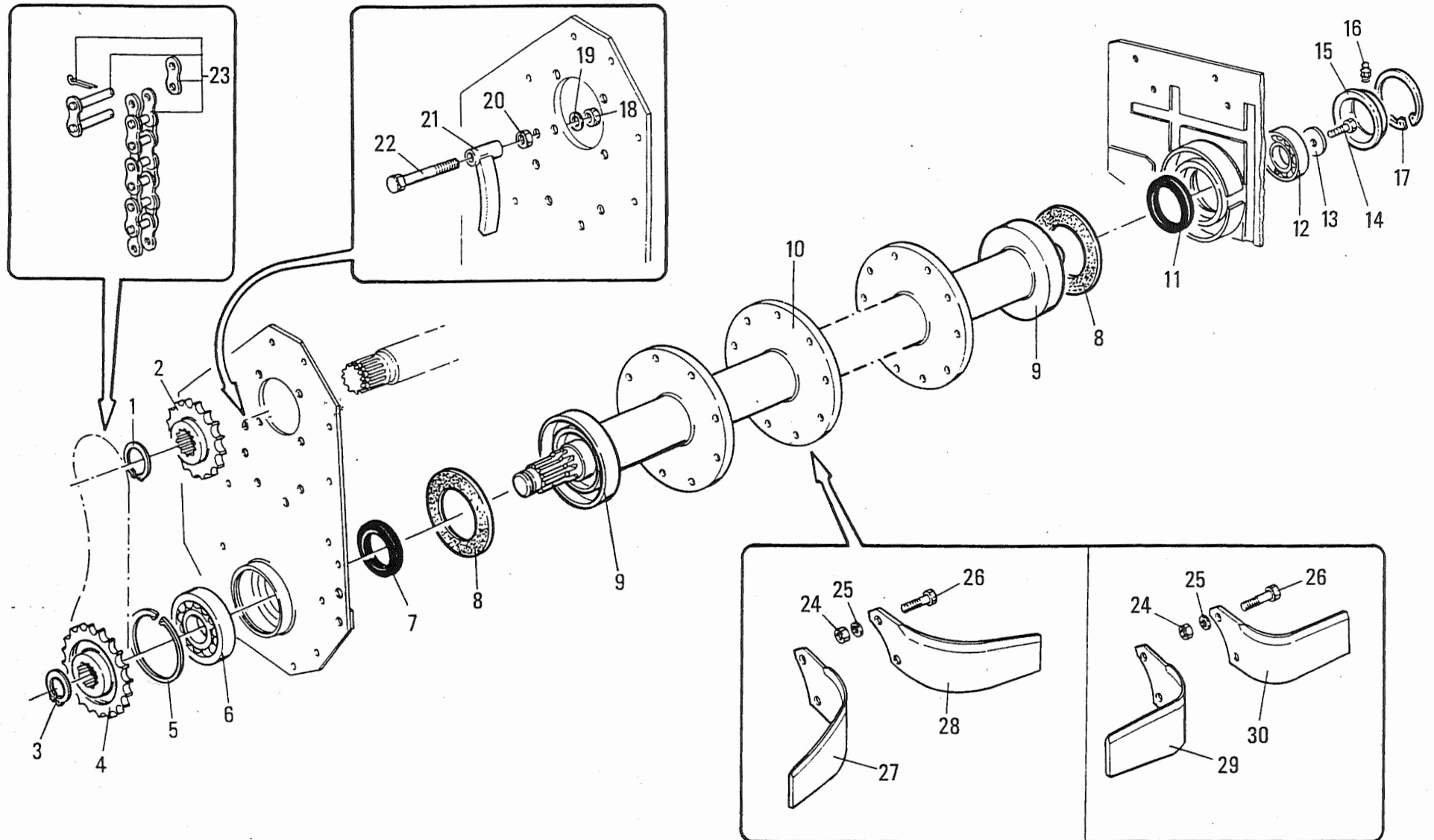

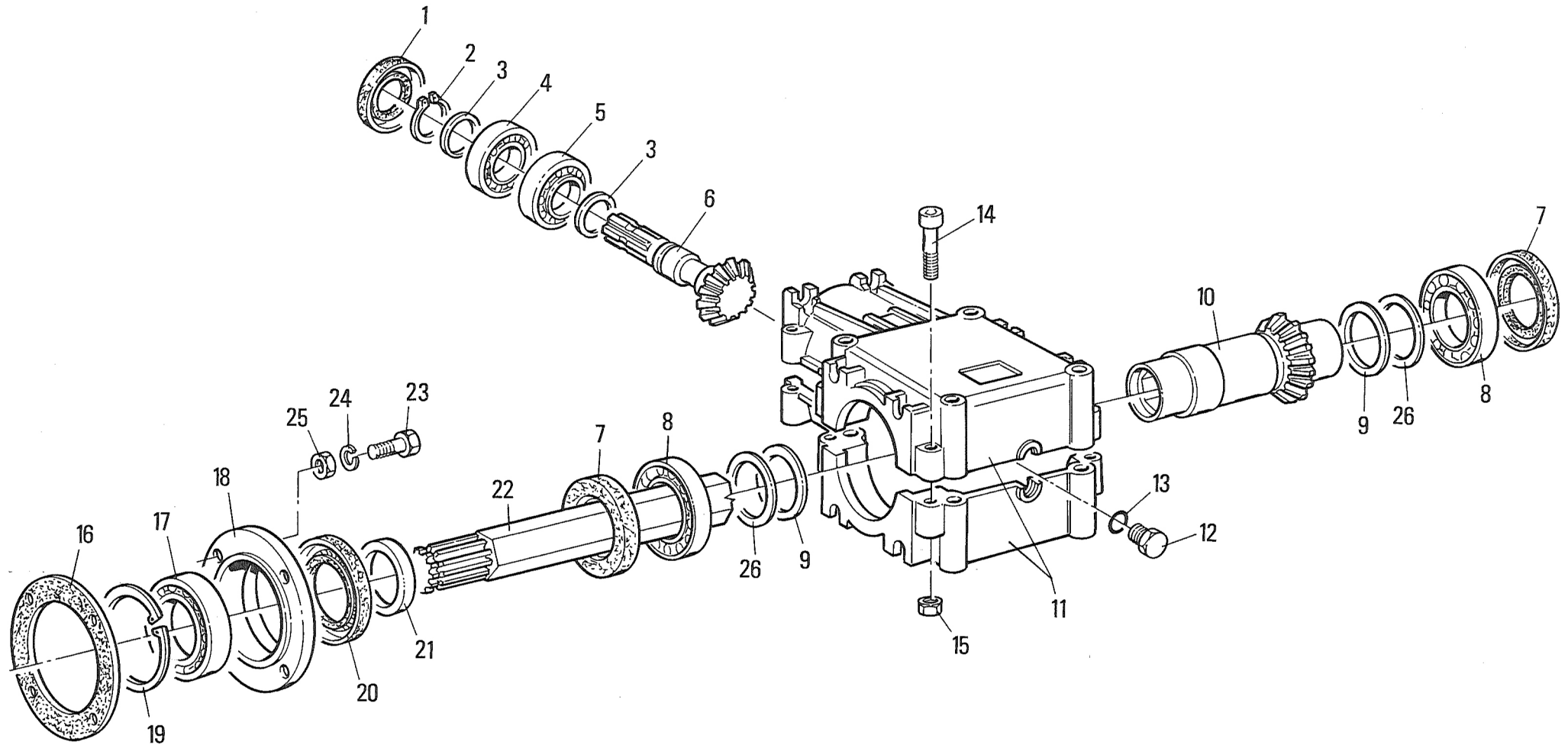

MURATORI MAS

TAV. 3.0

POS.	N°	CODICE Q.	DESCRIZIONE	DESIGNATION	BENENNUNG	DESCRIPTION	DESIGNAZIONE	Da matr.	Fino matr.
								De nr. serie Vom Seriennr. From serial nr.	Jusqu'au nr. serie Bis Seriennr. Up to serial nr.
1	66011600	1	ANELLO TENUTA	JOINT D'ETANCHEITE	DICHTUNGSRING	JUNT RING	35 x 62 x 7	32190	
2	63000600	1	ANELLO ELASTICO	ARREOTIR	SPANNRING	SNAP-RING	Ø 35 E UNI 7435	32190	
3	68052300	2	SPESSORE	EPAISSEUR	DICKE	THICKNESS	45 x 35 x 06	32190	
4	67003700	1	CUSCINETTO	ROULEMENT	LAGER	BEARING	6207	32190	
5	67002100	1	CUSCINETTO	ROULEMENT	LAGER	BEARING	6307	32190	
6	10012700	1	ALBERO	ARBRE	WELLE	SHAFT	Z 13 M 5	32190	
7	66011700	2	ANELLO TENUTA	JOINT D'ETANCHEITE	DICHTUNGSRING	JUNT RING	50 x 62 x 7	32190	
8	67006600	2	CUSCINETTO	ROULEMENT	LAGER	BEARING	6010	32190	
9	32122300	2	DISTANZIALE	ENTRETOISE	DISTANZSTUECK	SPACER		32190	
10	10030700	1	CORONA	COURONNE	KRANZ	CROWN		32190	
11	03001400	2	SEMISCATOLA	DEMI-CARTER	GEHAUESHAELFTE	HALF CASE		32190	
12	68051300	1	TAPPO	BOUCHON	STOPFEN	PLUG		32190	
13	66011100	1	ANELLO TENUTA	JOINT D'ETANCHEITE	DICHTUNGSRING	JUNT RING	OR 3062	32190	
14	60020500	8	VITE	VIS	SCHRAUBE	SCREW	TCEI 8 x 55 UNI 5931 8.8	32190	
15	62000700	8	DADO	ECROU	MUTTER	NUT	M 8 x 1,25 UNI 5587	32190	
16	80009000	1	GUARNIZIONE	GARNITURE	DICHTUNG	SEAL			
17	67002100	1	CUSCINETTO	ROULEMENT	LAGER	BEARING	6307		
18	01008701	1	SUPPORTO	SUPPORT	TRAEGER	SUPPORT			
19	63000200	1	ANELLO ELASTICO	ARREOTIR	SPANNRING	SNAP-RING	Ø 80 I UNI 7437		
20	66002100	1	ANELLO TENUTA	JOINT D'ETANCHEITE	DICHTUNGSRING	JUNT RING	45 x 72 x 10		
21	32031700	1	BOCCOLA	DOUILLE	BUECHSE	BUSHING			
22	38008600	1	SEMIASSE	DEMI-ESSIEU	ACHSWELLE	AXLE SHAFT	MAS 085		
22	38008700	1	SEMIASSE	DEMI-ESSIEU	ACHSWELLE	AXLE SHAFT	MAS 105		
22	38008800	1	SEMIASSE	DEMI-ESSIEU	ACHSWELLE	AXLE SHAFT	MAS 115		
22	38008900	1	SEMIASSE	DEMI-ESSIEU	ACHSWELLE	AXLE SHAFT	MAS 125		
22	38009000	1	SEMIASSE	DEMI-ESSIEU	ACHSWELLE	AXLE SHAFT	MAS 135		

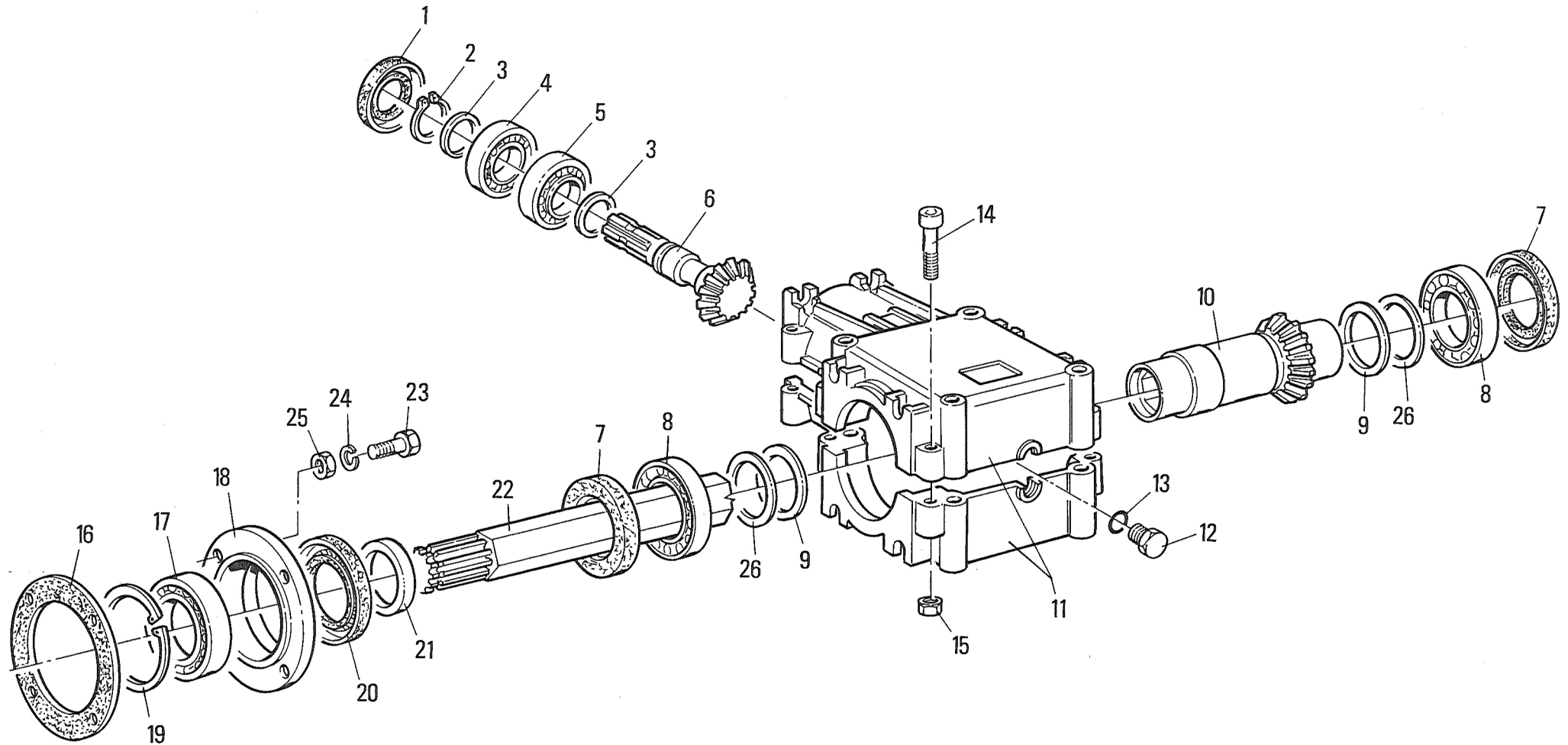

fino matricola - jusqu' au nr. serie - bis Seriennr. - up to serial nr. **32189**

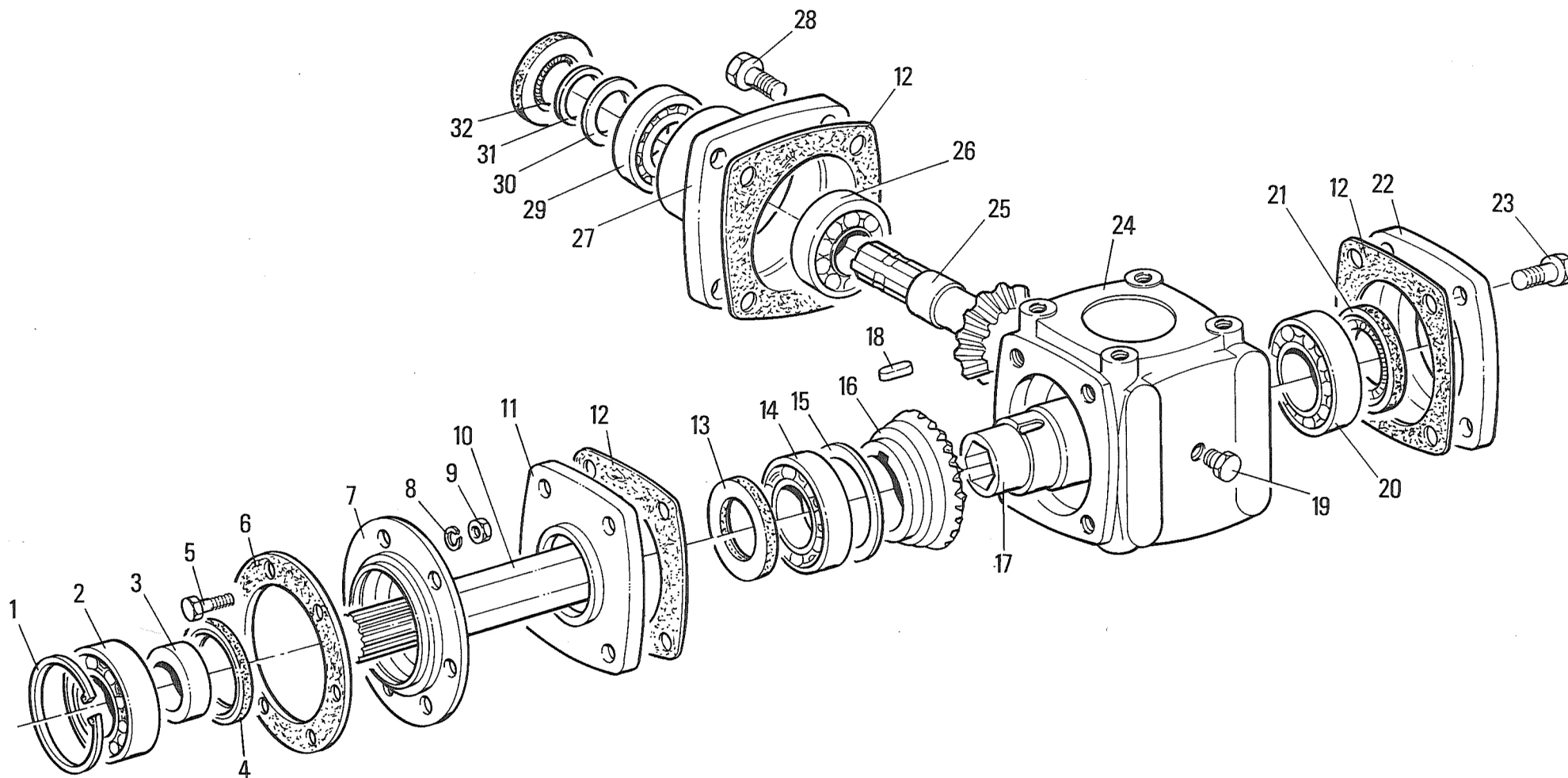

MURATORI MAS

TAV. 4.0

POS.	N°	CODICE Q.	DESCRIZIONE	DESIGNATION	BENENNUNG	DESCRIPTION	DESIGNAZIONE	Da matr.	Fino matr.
								De nr. serie Vom Seriennr. From serial nr.	Jusqu'au nr. serie Bis Seriennr. Up to serial nr.
1	63000200	1	ANELLO ELASTICO	ARREOTIR	SPANNRING	SNAP-RING	Ø 80 I UNI 7437		
2	67002100	1	CUSCINETTO	ROULEMENT	LAGER	BEARING	6307		
3	32031700	1	BOCCOLA	DOUILLE	BUECHSE	BUSHING			
4	66002100	1	ANELLO TENUTA	JOINT D'ETANCHEITE	DICHTUNGSRING	JUNT RING	45 x 72 x 10		
5	60000400	6	VITE	VIS	SCHRAUBE	SCREW	TE 10 x 30 UNI 5739 8.8		23432
5	60000500	4	VITE	VIS	SCHRAUBE	SCREW	TE 12x 30 UNI 5739 8.8	23433	
6	80009000	1	GUARNIZIONE	GARNITURE	DICHTUNG	SEAL			
7	01008700	1	SUPPORTO	SUPPORT	TRAEGER	SUPPORT			24432
7	01008701	1	SUPPORTO	SUPPORT	TRAEGER	SUPPORT		23433	
8	61000400	6	RONDELLA	RONDELLE	SCHEIBE	WASHER	DENT. INT. Ø 10 UNI 3704		23432
8	61000500	4	RONDELLA	RONDELLE	SCHEIBE	WASHER	DENT. INT. Ø 12 UNI 3704	23433	
9	62000500	6	DADO	ECROU	MUTTER	NUT	M 10 x 1,5 UNI 5587		23432
9	62000600	4	DADO	ECROU	MUTTER	NUT	M 12 x 1,75 UNI 5587	23433	
10	38008600	1	SEMIASSE	DEMI-ESSIEU	ACHSWELLE	AXLE SHAFT	MAS 085		
10	38008700	1	SEMIASSE	DEMI-ESSIEU	ACHSWELLE	AXLE SHAFT	MAS 105		
10	38008800	1	SEMIASSE	DEMI-ESSIEU	ACHSWELLE	AXLE SHAFT	MAS 115		
10	38008900	1	SEMIASSE	DEMI-ESSIEU	ACHSWELLE	AXLE SHAFT	MAS 125		
10	38009000	1	SEMIASSE	DEMI-ESSIEU	ACHSWELLE	AXLE SHAFT	MAS 135		
10	38009100	1	SEMIASSE	DEMI-ESSIEU	ACHSWELLE	AXLE SHAFT	MAS 145		
11	01008500	1	COPERCHIO	COUVERCLE	DECKEL	COVER			32189
12	80006500	3	GUARNIZIONE	GARNITURE	DICHTUNG	SEAL			32189
13	66003900	1	ANELLO TENUTA	JOINT D'ETANCHEITE	DICHTUNGSRING	JUNT RING	50 x 65 x 8		32189
14	67006600	1	CUSCINETTO	ROULEMENT	LAGER	BEARING	6010		32189
15	68013000	1	SPESSORE	EPAISSEUR	DICKE	THICKNESS	80 x 63 x 1		32189
16	10017100	1	CORONA CONICA	COURONNE CONIQUE	KEGELKRANZ	RING BEVEL	Z 19		32189
17	32047100	1	CANOTTO ESAGONALE	TUBE	ROHR	TUBE			32189

fino matricola - jusqu' au nr. serie - bis Seriennr. - up to serial nr. **32189**

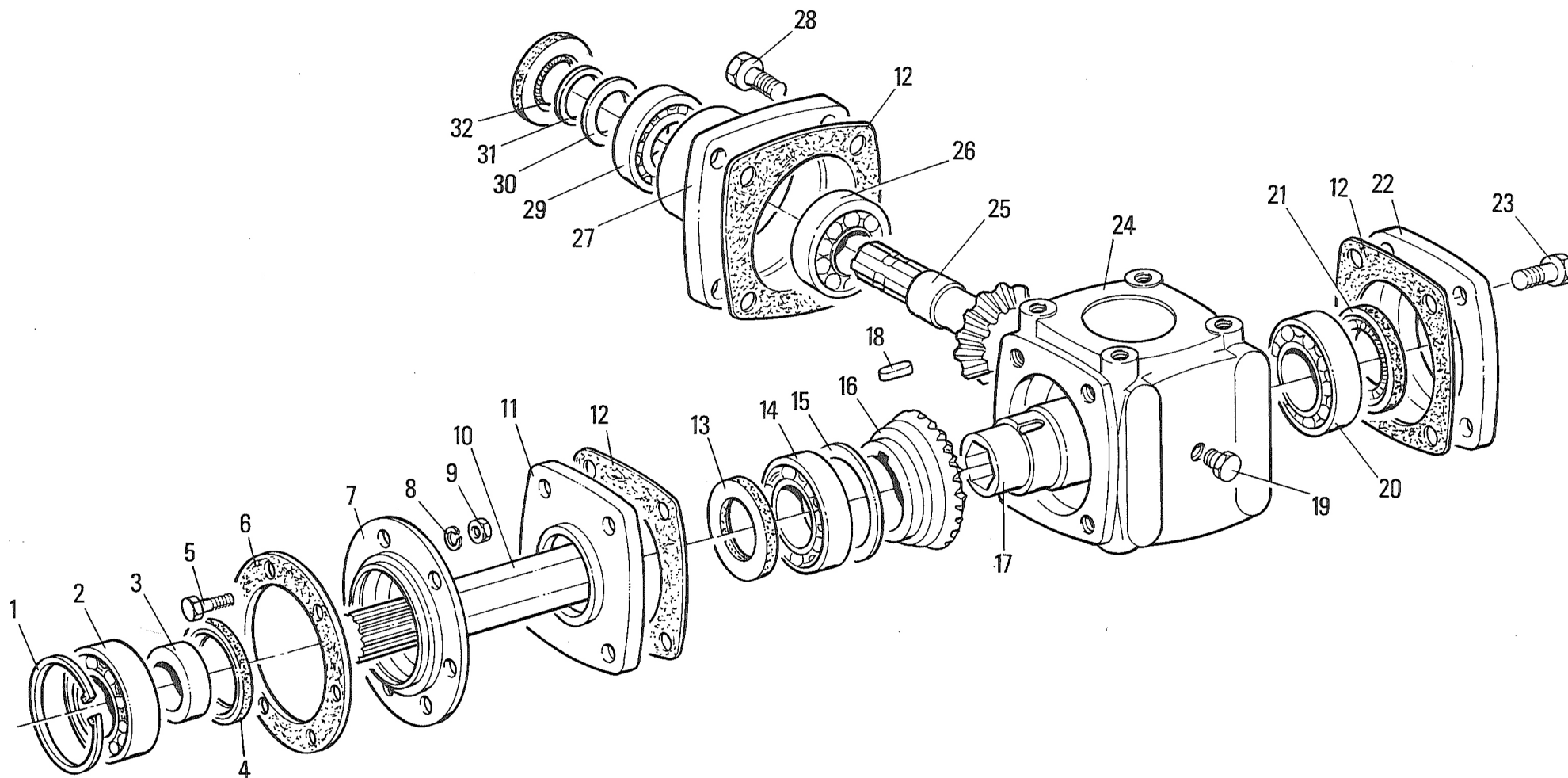

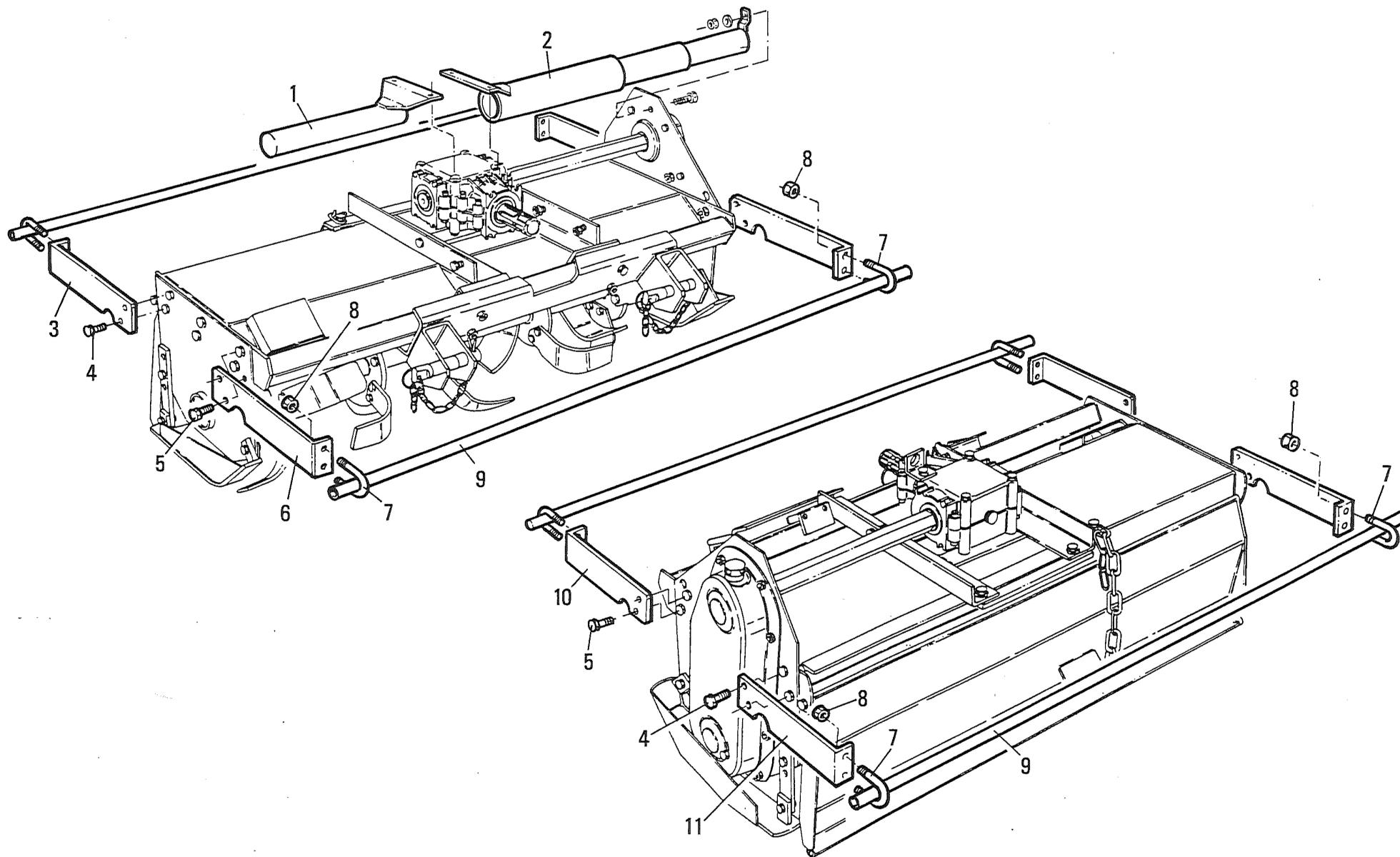

MURATORI MAS

TAV. 5.0

POS.	N°	CODICE Q.	DESCRIZIONE	DESIGNATION	BENENNUNG	DESCRIPTION	DESIGNAZIONE	Da matr.	Fino matr.
								De nr. serie Vom Seriennr. From serial nr.	Jusqu'au nr. serie Bis Seriennr. Up to serial nr.
1	40201700	1	PROTEZIONE	PROTECTION	SCHUTZ	GUARD	085		
1	40201900	1	PROTEZIONE	PROTECTION	SCHUTZ	GUARD	105-115		
1	40202000	1	PROTEZIONE	PROTECTION	SCHUTZ	GUARD	125		
1	40202200	1	PROTEZIONE	PROTECTION	SCHUTZ	GUARD	135-145		
2	45083600	1	PROTEZIONE	PROTECTION	SCHUTZ	GUARD	085		
2	45083700	1	PROTEZIONE	PROTECTION	SCHUTZ	GUARD	105		
2	45083800	1	PROTEZIONE	PROTECTION	SCHUTZ	GUARD	115		
2	45083900	1	PROTEZIONE	PROTECTION	SCHUTZ	GUARD	125		
2	45084000	1	PROTEZIONE	PROTECTION	SCHUTZ	GUARD	135		
2	45084100	1	PROTEZIONE	PROTECTION	SCHUTZ	GUARD	145		
2	45084200	1	PROTEZIONE	PROTECTION	SCHUTZ	GUARD	165		
3	30154500	1	STAFFA POST. DX	BRIDE	BUEGEL	BRACKET			
4	60021300	2	VITE	VIS	SCHRAUBE	SCREW	TE 10 x 30 UNI 5739		
5	60017900	2	VITE	VIS	SCHRAUBE	SCREW	TE 10 x 25 UNI 5739		
6	30154300	1	STAFFA ANT. DX	BRIDE	BUEGEL	BRACKET			
7	38022100	4	CAVALLOTTO	ARRETOIR	KLEMMSTUECK	UBOLT			
8	62010100	8	DADO	ECROU	MUTTER	NUT	M 6 x 1 AUTOBLOCC.		
9	32148000	2	TUBO	TUBE	ROHR	TUBE	085		
9	32148200	2	TUBO	TUBE	ROHR	TUBE	105		
9	32148300	2	TUBO	TUBE	ROHR	TUBE	115		
9	32148400	2	TUBO	TUBE	ROHR	TUBE	125		
9	32148500	2	TUBO	TUBE	ROHR	TUBE	135		
9	32148600	2	TUBO	TUBE	ROHR	TUBE	145		
10	30154200	1	STAFFA POST. SX	BRIDE	BUEGEL	BRACKET			
11	30154400	1	STAFFA ANT. SX	BRIDE	BUEGEL	BRACKET			



MURATORI S.p.A.

Via Pavarello, 21 - 41051 Castelnuovo Rangone (MO) Italy - Tel. 059.5330611 Fax 059.537259

www.muratoriequip.it *info@muratoriequip.it*

Capitale sociale Euro 480.000 interamente versato

Registro Imprese di Modena

Codice fiscale e numero d'iscrizione: 00708860366