

MURATORINI

**TIPO-TYPE-TYP
ME12
ME12C**

**CATALOGO RICAMBI
Catalogue Pièces Detachées
Ersatzteilkatalog
Spare Parts Catalogue
Catálogo Recambios**

EDIZIONE 10/2004

Per ordinare parti di ricambio specificare:

- tipo e matricola della macchina (apposti sulla macchina o sui documenti di acquisto);
- numero del riferimento del pezzo nel disegno (Pos.), numero della tavola (Tav.) e numero di codice

N.B.: le indicazioni destro o sinistro vengono date guardando la macchina da dietro.

Pour les commandes de pièces de rechange veuillez spécifier:

- *type et numéro de série de la machine (indiqués sur la machine et sur le bon d'achat);*
- *numéro de référence du pièce sur le plan (Pos.), numéro du plan (Tav.) et numéro de code (codice)*

N.B.: *les indications droite ou gauche sont données en regardant la machine par derrière.*

Zum Bestellen von Ersatzteilen folgendes angeben:

- *Typ und Serien-Nr. der Maschine (zu finden auf der Maschine oder der Einkaufspapieren);*
- *Bezug-Nr. des Ersatzteils auf der Zeichnung (Pos.), Zeichnungsnummer (Tav.) und Kodenummer (codice)*

N.B.: *Die Angaben rechts und links verstehen sich so, dass man hinter der Maschine steht.*

When ordering spare parts specify:

- machine type and serial number (found on the machine or on the purchasing documents);
- reference number of the part on the relative drawing (Pos.), number of the drawing (Tav.) and part number (codice)

N.B.: right-hand or left-hand indications are made by viewing the machine from the rear.

TAV. 1.0

GRUPPO TELAIO
ENSEMBLE CHASSIS
SATZ FÜR RAHMEN
KIT FOR FRAME

TAV. 2.0

GRUPPO ROTORI
ENSEMBLE ROTORS
SATZ FÜR ROTOREN
KIT FOR ROTORS

TAV. 3.0

GRUPPO RIDUTTORE A 1 VELOCITA'
ENSEMBLE BOITIER MONOVITESSE
SATZ FÜR EINGANGGETRIEBE
KIT FOR ONE-SPEED GEAR BOX

TAV. 4.0

GRUPPO RIDUTTORE A 4 VELOCITA'
ENSEMBLE BOITIER 4 VITESSE
SATZ FÜR 4-GANGGETRIEBE
KIT FOR 4-SPEED GEAR BOX

TAV. 5.0

GRUPPO RULLO POSTERIORE
ENSEMBLE ROULEAU ARRIERE
SATZ HINTERE WALZE
KIT REAR ROLLER

TAV. 6.0

BARRA LIVELLATRICE POSTERIORE
BARRE NIVELLEUSE ARRIERE
HINTERE PLANIERSCHIENE
REAR LEVELLING BAR

TAV. 7.0

PROTEZIONI ANTINFORTUNISTICHE "CE"
PROTECTIONS "CE"
UNFALLSCHUTZVORRICHTUNGEN "CE"
SAFETY GUARDS "CE"

TAV. 8.0

PROTEZIONI ANTINFORTUNISTICHE "GB"
PROTECTIONS "GB"
UNFALLSCHUTZVORRICHTUNGEN "GB"
SAFETY GUARDS "GB"

TAV. 9.0

ATTACCO POSTERIORE MECCANICO
ATTELAGE ARR. MECANIQUE
HINT. MECHANISCHES HITCH
REAR MECHANICAL HITCH

TAV. 10.0

ATTACCO POSTERIORE IDRAULICO
ATTELAGE ARR. HYDRAULIQUE
HINT. HYDRAULISCHES HITCH
REAR HYDRAULIC HITCH

TAV. 11.0

BARRE ANTIFLESSIONE
BARRES 3/POINTS RENFORCEES
SEITL. VERSTAERKERUNGEN
SIDE REINFORCING BARS

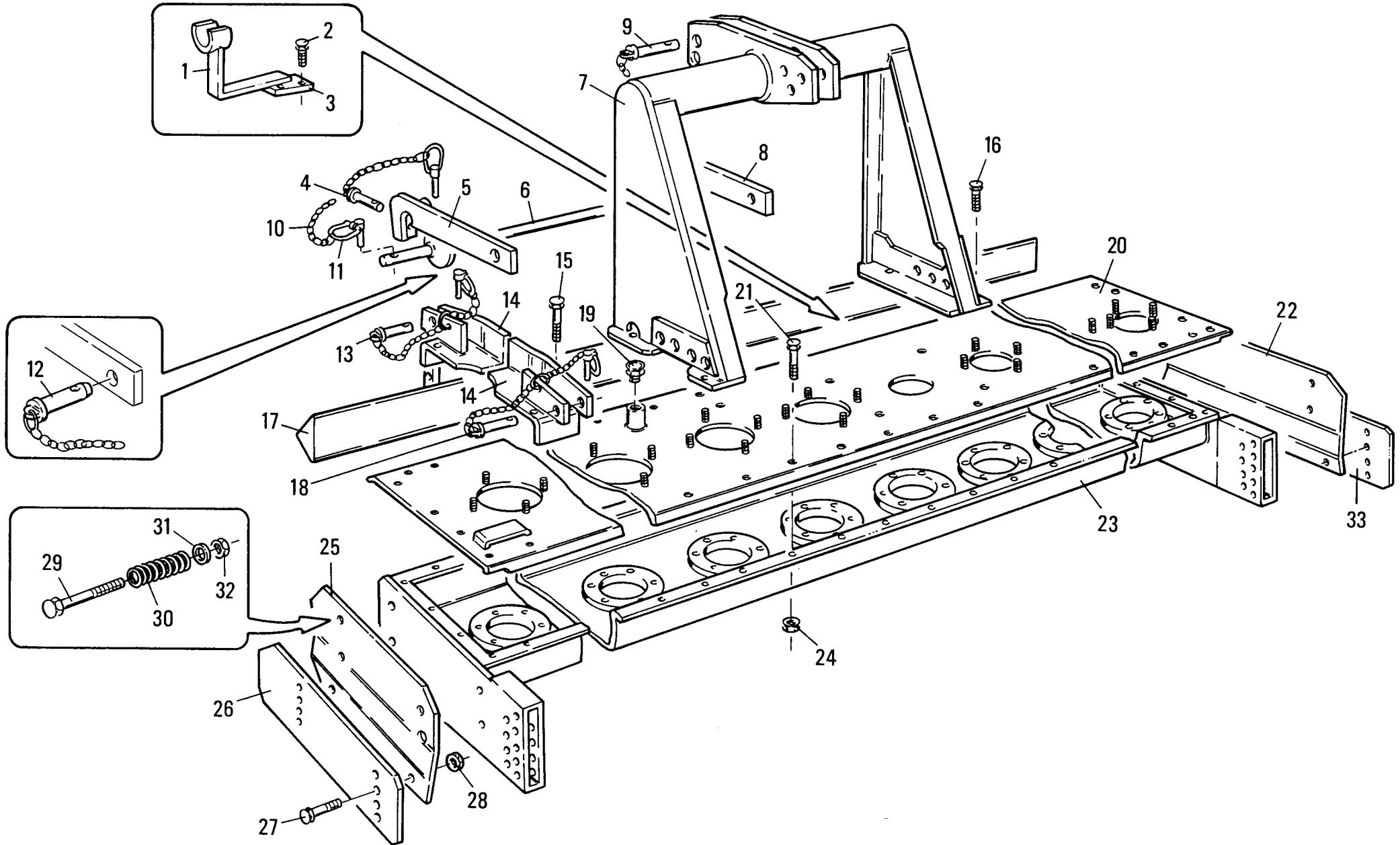

MURATORI ME12 - ME12C
TAV. 1.0

POS.	N° CODICE	Q	DESCRIZIONE	DESIGNATION	BENENNUNG	DESCRIPTION	DESIGNAZIONE	Da matr.	Fino matr
								De nr. serie Vom Seriennr. From serial nr.	Jusqu'au nr. serie Bis Seriennr. Up to serial nr.
1	40186300	1	GANCIO	CROCHET	HAKEN	HOOK			
2	60034100	2	VITE	VIS	SCHRAUBE	SCREW	TE 10 x 1,25 x 45 UNI 5740		
3	30144300	1	PIASTRA	PLAQUE	PLATTE	PLATE			
4	68062000	2	PERNO	PIVOT	BOLZEN	PIN			
5	40186500	1	BRACCIO SX	BRAS (G)	ARM (LINKS)	ARM (LH)			
6	40186600	1	BARRA	BARRE	STANGE	BAR			
7	40186700	1	ATTACCO	ATTACHE	ANSCHLUSS	ATTACHMENT			
8	40186400	1	BRACCIO DX	BRAS (D)	ARM (RECHTS)	ARM (RH)			
9	68062100	1	PERNO	PIVOT	BOLZEN	PIN			
10	68062900	2	CATENA	CHAINE	KETTE	CHAIN			
11	64001900	2	MOLLA A SCATTO	RESSORT	FEDER	SPRING	Ø 10		
12	68062100	2	PERNO	PIVOT	BOLZEN	PIN			
13	68062000	2	PERNO	PIVOT	BOLZEN	PIN			
14	40220100	2	MONTANTE ANT.	MONTANT	SAEULE	PILLAR			
14	40189900	2	MONTANTE POST.	MONTANT	SAEULE	PILLAR			
15	60033700	8	VITE	VIS	SCHRAUBE	SCREW	TE 10 x 1,25 x 35 UNI 5740		
16	60034100	12	VITE	VIS	SCHRAUBE	SCREW	TE 10 x 1,25 x 45 UNI 5740		
17	40184800	1	BARRA ANT.	BARRE	STANGE	BAR	200		
17	40184900	1	BARRA ANT.	BARRE	STANGE	BAR	250		
17	40185000	1	BARRA ANT.	BARRE	STANGE	BAR	300		
18	68062000	2	PERNO	PIVOT	BOLZEN	PIN			
19	68078400	1	TAPPO	BOUCHON	STOPFEN	PLUG			
20	40149200	1	COPERCHIO	COUVERCLE	DECKEL	COVER	200	60594	
20	40149400	1	COPERCHIO	COUVERCLE	DECKEL	COVER	250	60594	
20	40149500	1	COPERCHIO	COUVERCLE	DECKEL	COVER	300	60594	
20	40218000	1	COPERCHIO	COUVERCLE	DECKEL	COVER	200	60595	

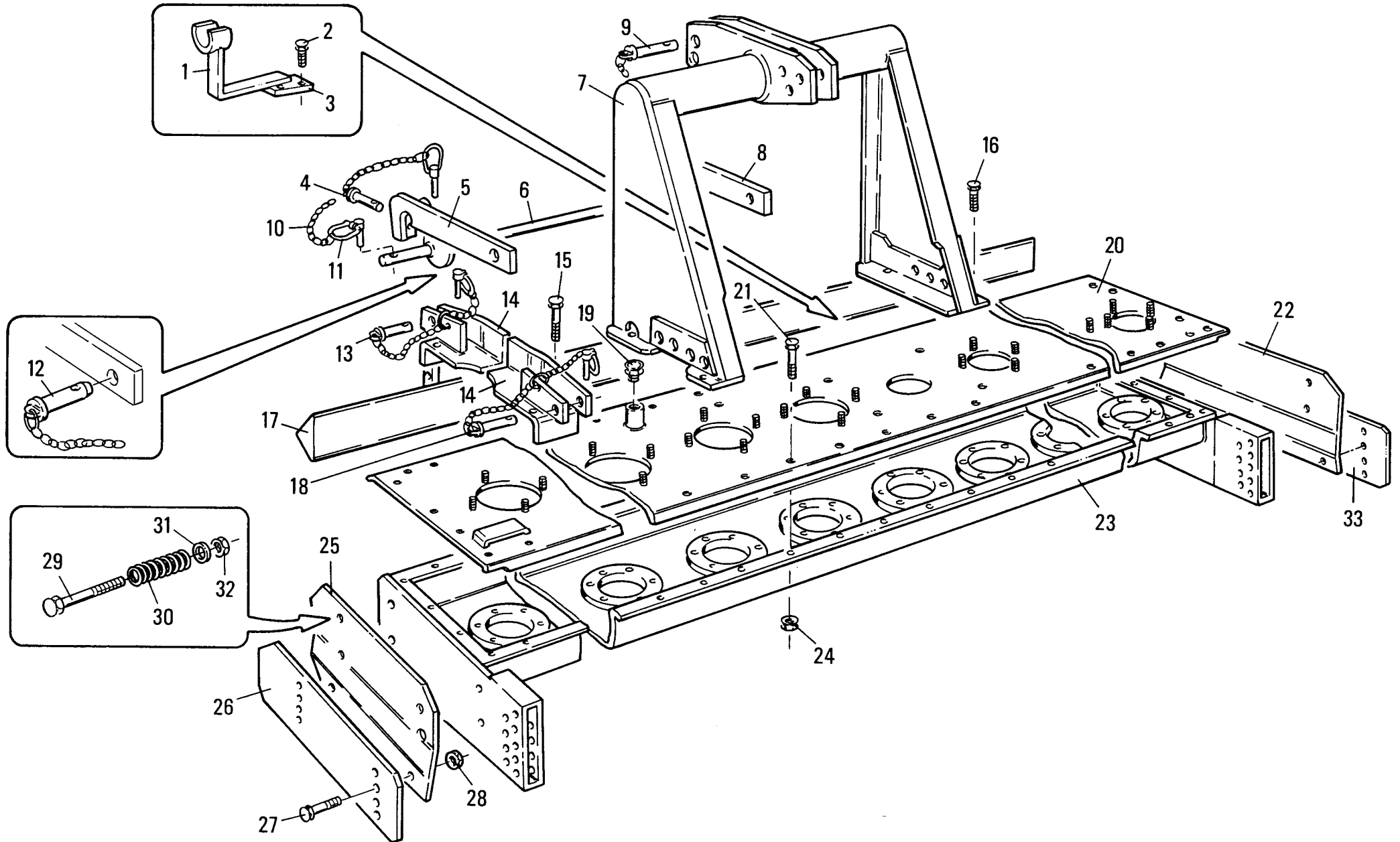

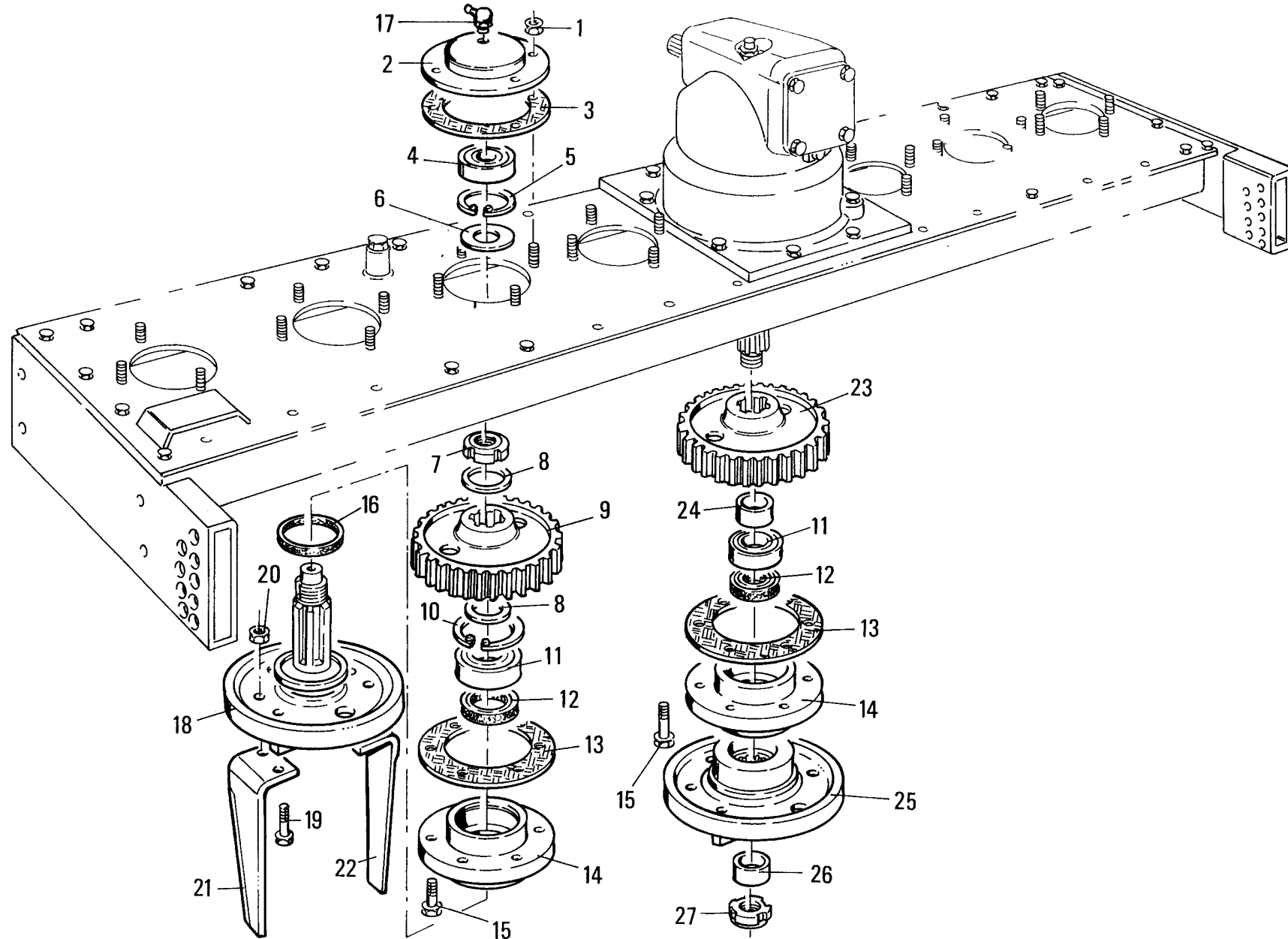

MURATORI ME12 - ME12C

TAV. 2.0

POS.	N° CODICE Q	DESCRIZIONE	DESIGNATION	BENENNUNG	DESCRIPTION	DESIGNAZIONE	Da matr.	Fino matr
							De nr. serie Vom Seriennr. From serial nr.	Jusqu'au nr. serie Bis Seriennr. Up to serial nr.
1	62010300	DADO	ECROU	MUTTER	NUT	M 10 x 1,25 AUTOBLOCC.		
2	10033000	SUPPORTO	SUPPORT	TRAEGER	SUPPORT			79572
2	10042900	SUPPORTO	SUPPORT	TRAEGER	SUPPORT		79573	
3	80014700	GUARNIZIONE	GARNITURE	DICHTUNG	SEAL			
4	67012500	CUSCINETTO	ROULEMENT	LAGER	BEARING	6007 2RS1		79572
4	67018500	CUSCINETTO	ROULEMENT	LAGER	BEARING	6007	79573	
5	63005200	ANELLO ELASTICO	ARRETOIR	SPANNRING	SNAP-RING	Ø 62 DIN 472		
6	39196300	PROTEZIONE	PROTECTION	SCHUTZ	GUARD			
7	62013700	GHIERA	FRETTE	NUTMUTTER	RING NUT	M 40 x 1,5 AUTOBLOCC.		
8	32120600	SPESSORE	EPAISSEUR	DICKE	THICKNESS			
9	10032800	INGRANAGGIO LATERALE	ENGRANAGE LAT.	ZAHNRAD (SEITL.)	SIDE GEAR			
10	63005300	ANELLO ELASTICO	ARRETOIR	SPANNRING	SNAP-RING	Ø 85 DIN 472		
11	67004800	CUSCINETTO	ROULEMENT	LAGER	BEARING	6209		
12	66015100	ANELLO TENUTA	JOINT D'ETANCHEITE	DICHTUNGSRING	JUNT RING	60 x 75 x 8		
13	80014600	GUARNIZIONE	GARNITURE	DICHTUNG	SEAL			
14	10033101	SUPPORTO	SUPPORT	TRAEGER	SUPPORT			
15	60019700	VITE	VIS	SCHRAUBE	SCREW	TE 12 x 1,5 x 30 UNI 5740		
16	68075100	FELTRO	FEUTRE	FILZ	FELT			
17	64004300	INGRASSATORE	GRAISSEUR	SCHMIERNIPPEL	GREASE FITTING	M 12 x 1,75	79573	
18	45100500	ROTORE	ROTOR	ROTOR	ROTOR			
19	60025100	VITE	VIS	SCHRAUBE	SCREW	TE 16 x 1,5 x 50 UNI 5740		
20	62010900	DADO	ECROU	MUTTER	NUT	M 16 x 1,5 AUTOBLOCC.		
21	12016500	LAMA SX	COUTEAU G.	L. MESSER	LH. BLADE			
22	12016400	LAMA DX	COUTEAU D.	R. MESSER	RH. BLADE			
23	10032700	1 INGRANAGGIO CENTRALE	ENGRANAGE CENTR.	ZAHNRAD (ZENTR.)	CENTRAL GEAR			
24	32120400	1 DISTANZIALE	ENTRETOISE	DISTANZSTUECCK	SPACER			

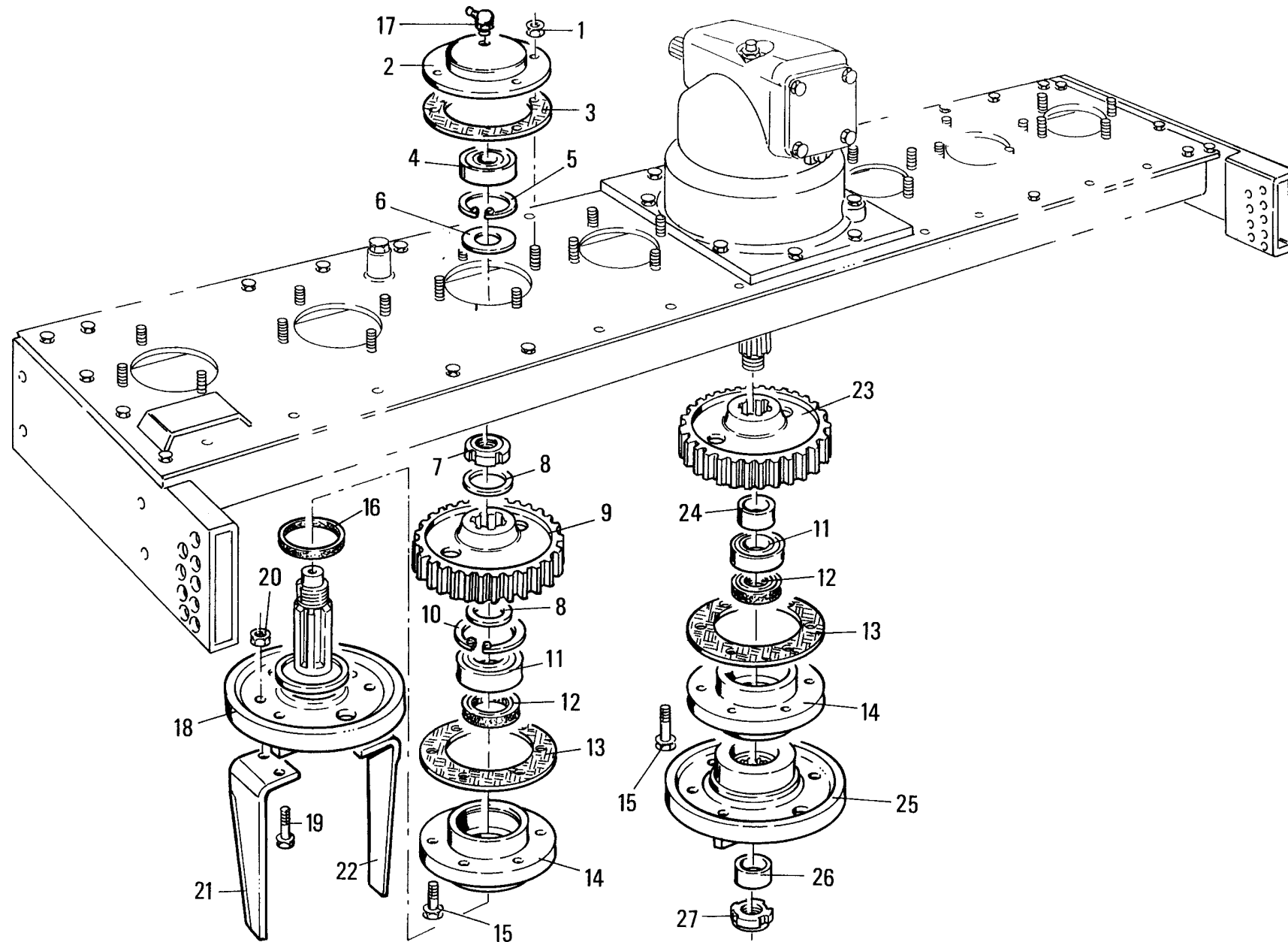

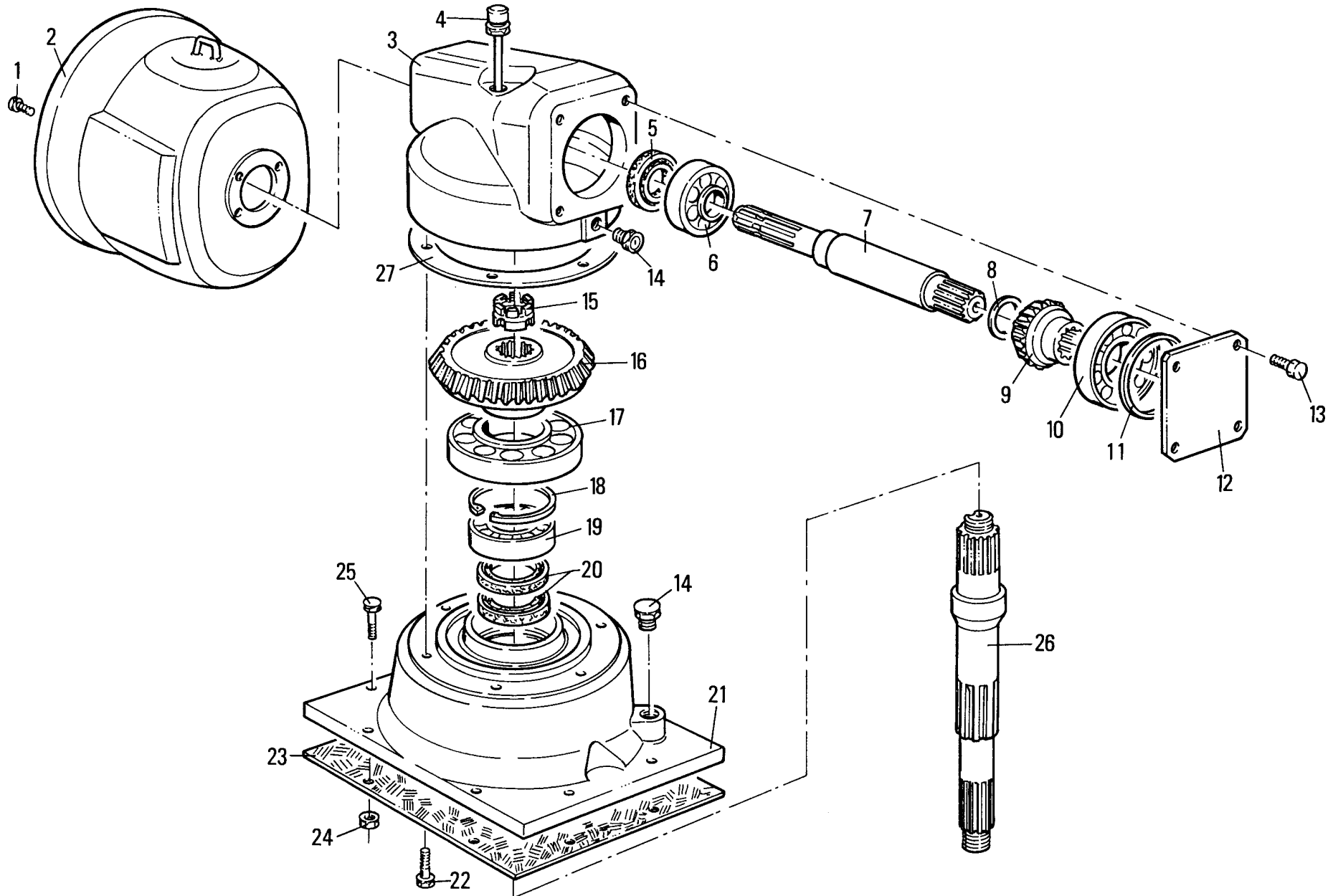

MURATORI ME12
TAV. 3.0

POS.	N° CODICE	Q	DESCRIZIONE	DESIGNATION	BENENNUNG	DESCRIPTION	DESIGNAZIONE	Da matr.	Fino matr
								De nr. serie Vom Seriennr.	Jusqu'au nr. serie Bis Seriennr.
								From serial nr.	Up to serial nr.
1	60021600	4	VITE	VIS	SCHRAUBE	SCREW	TE 10 x 1,5 x 20 UNI 5739		
2	68077000	1	PROTEZIONE	PROTECTION	SCHUTZ	GUARD			
3	01016400	1	SCATOLA	CARTER	GEHAEUSE	GEARBOX			
4	68078700	1	TAPPO	BOUCHON	STOPFEN	PLUG			
5	66015700	1	ANELLO TENUTA	JOINT D'ETANCHEITE	DICHTUNGSRING	JUNT RING			
6	67005500	1	CUSCINETTO	ROULEMENT	LAGER	BEARING	32207		
7	31071700	1	ALBERO	ARBRE	WELLE	SHAFT			
8	68078900		SPESSORE	EPAISSEUR	DICKE	THICKNESS	50 x 40		
9	10038600	1	PIGNONE CONICO	PIGNON CONIQUE	KEGELRITZEL	BEVEL PINION	Z= 14		
10	67009600	1	CUSCINETTO	ROULEMENT	LAGER	BEARING	30212		
11	68079000		SPESSORE	EPAISSEUR	DICKE	THICKNESS	110 x 95		
12	01016600	1	COPERCHIO	COUVERCLE	DECKEL	COVER			
13	60017900	4	VITE	VIS	SCHRAUBE	SCREW	TE 10 x 25 UNI 5739		
14	68078800	2	TAPPO	BOUCHON	STOPFEN	PLUG	M 16 x 1,5		
15	62014200	1	GHIERA	FRETTE	NUTMUTTER	RING NUT	M 40 x 1,5 CON COLLARE		
16	10038700	1	CORONA CONICA	COURONNE CONIQUE	KEGELKRANZ	RING BEVEL	Z= 25		
17	67001600	1	CUSCINETTO	ROULEMENT	LAGER	BEARING	30214		
18	63000100	1	ANELLO ELASTICO	ARRETOIR	SPANNRING	SNAP-RING	Ø 90 I UNI 7437		
19	67009400	1	CUSCINETTO	ROULEMENT	LAGER	BEARING	30210		
20	66015800	2	ANELLO TENUTA	JOINT D'ETANCHEITE	DICHTUNGSRING	JUNT RING			
21	01016500	1	SUPPORTO	SUPPORT	TRAEGER	SUPPORT			
22	60021200	8	VITE	VIS	SCHRAUBE	SCREW	TE 12 x 35 UNI 5739		
23	80014800	1	GUARNIZIONE	GARNITURE	DICHTUNG	SEAL			
24	62010300	4	DADO	ECROU	MUTTER	NUT	M 10 x 1,25 AUTOBLOCC.		
25	60033700	8	VITE	VIS	SCHRAUBE	SCREW	TE 10 x 1,25 x 35 UNI 5740		
26	31071800	1	ALBERO	ARBRE	WELLE	SHAFT			

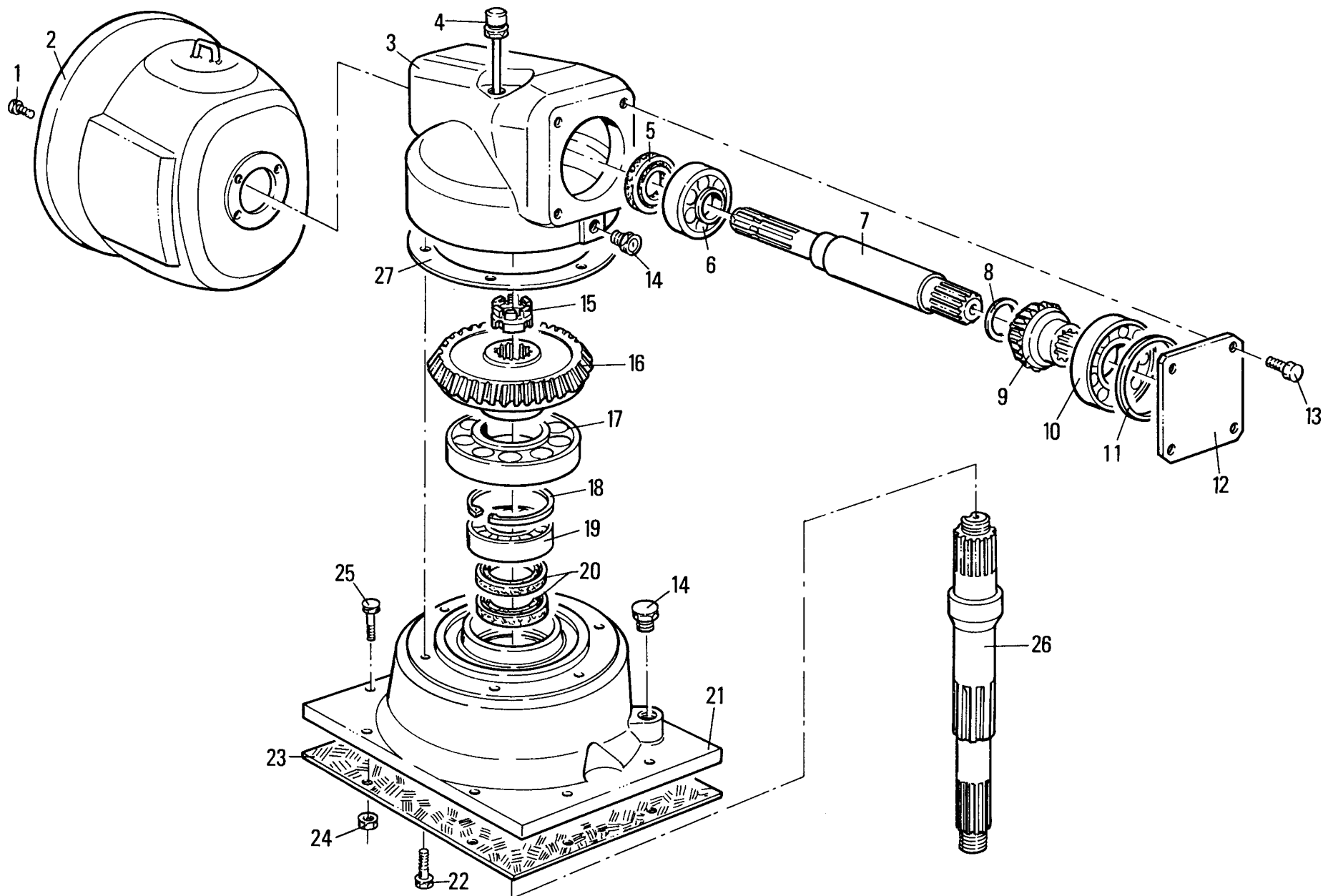

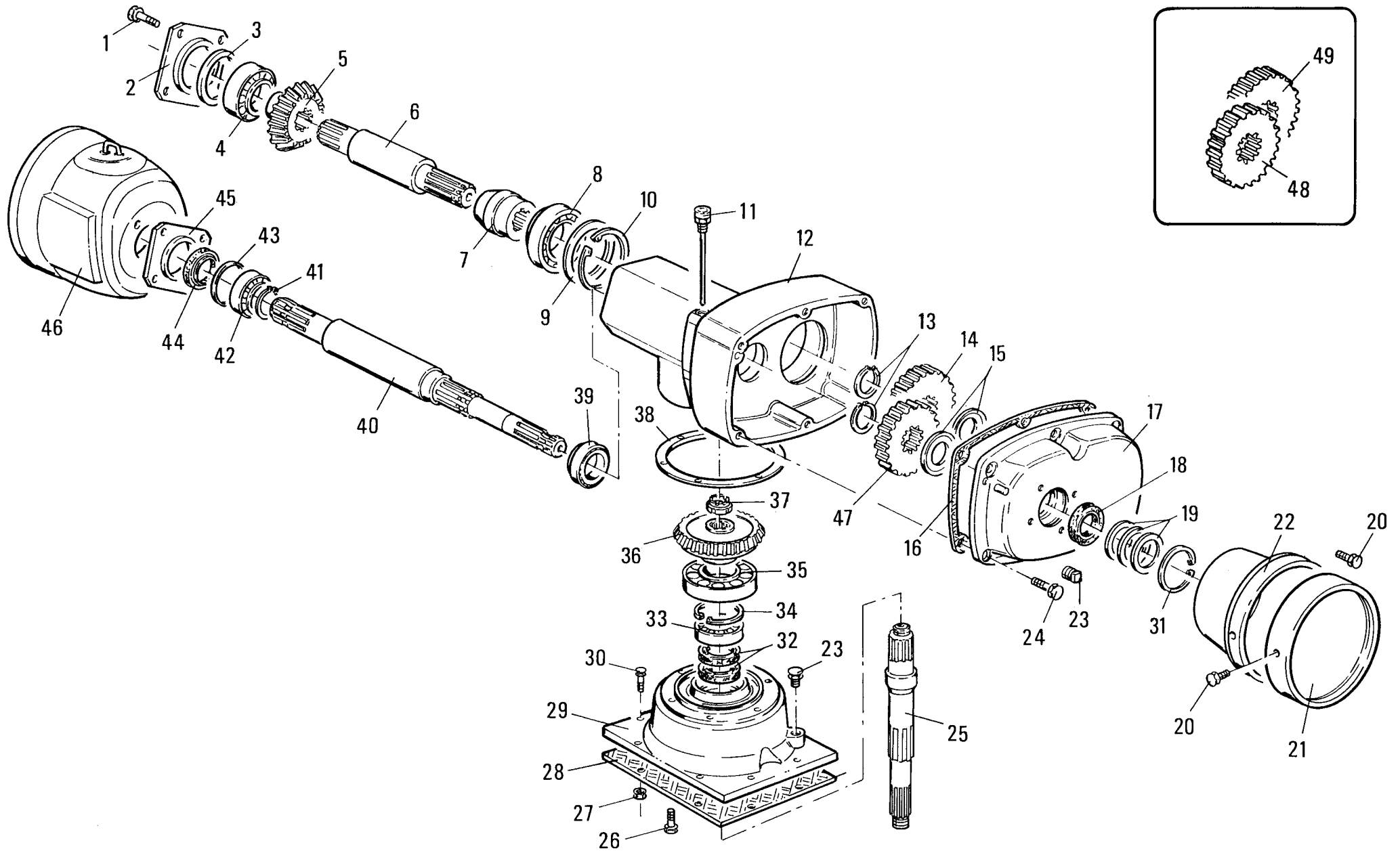

MURATORI ME12

TAV. 4.0

POS.	N° CODICE	Q	DESCRIZIONE	DESIGNATION	BENENNUNG	DESCRIPTION	DESIGNAZIONE	Da matr.	Fino matr
								De nr. serie Vom Seriennr.	Jusqu'au nr. serie Bis Seriennr.
								From serial nr.	Up to serial nr.
1	60021300	8	VITE	VIS	SCHRAUBE	SCREW	TE 10 x 30 UNI 5739		
2	01016800	1	COPERCHIO	COUVERCLE	DECKEL	COVER			
3	68079000		SPESSORE	EPAISSEUR	DICKE	THICKNESS			
4	67009600	1	CUSCINETTO	ROULEMENT	LAGER	BEARING	30212		
5	10038600	1	PIGNONE CONICO	PIGNON CONIQUE	KEGELRITZEL	BEVEL PINION			
6	31071900	1	ALBERO	ARBRE	WELLE	SHAFT			
7	32157800	1	BOCCOLA	DOUILLE	BUECHSE	BUSHING			
8	67009600	1	CUSCINETTO	ROULEMENT	LAGER	BEARING	30212		
9	68079000		SPESSORE	EPAISSEUR	DICKE	THICKNESS	110 x 95		
10	63002800	1	ANELLO ELASTICO	ARRETOIR	SPANNRING	SNAP-RING	Ø 110 I UNI 7437		
11	68080100	1	TAPPO	BOUCHON	STOPFEN	PLUG			
12	01016700	1	SCATOLA	CARTER	GEHAEUSE	GEARBOX			
13	63005800	2	ANELLO ELASTICO	ARRETOIR	SPANNRING	SNAP-RING	Ø 39 E UNI 7435		
14	31072200	1	INGRANAGGIO	PIGNON	ZAHNRAD	GEAR	Z 19		
15	68080200	2	MOLLA RITEGNO	RESSORT	FEDER	SPRING			
16	80015100	1	GUARNIZIONE	GARNITURE	DICHTUNG	SEAL			
17	03002500	1	COPERCHIO POST.	COUVERCLE	DECKEL	COVER			
18	66015700	1	ANELLO TENUTA	JOINT D'ETANCHEITE	DICHTUNGSRING	JUNT RING			
19	68011700	3	SPESSORE	EPAISSEUR	DICKE	THICKNESS	45 x 62 x 2		
20	60015100	4	VITE	VIS	SCHRAUBE	SCREW	TE 8 x 16 UNI 5739		
21	40180000	1	CHIUSURA	FERMATURE	VERSCHLUSS	LOCK			
22	68074300	1	PROTEZIONE	PROTECTION	SCHUTZ	GUARD			
23	68078800	2	TAPPO	BOUCHON	STOPFEN	PLUG	M16 x 1,5		
24	60021300	6	VITE	VIS	SCHRAUBE	SCREW	TE 10 x 30 UNI 5739		
25	31071800	1	ALBERO	ARBRE	WELLE	SHAFT			
26	60021200	8	VITE	VIS	SCHRAUBE	SCREW	TE 12 x 35 UNI 5739		

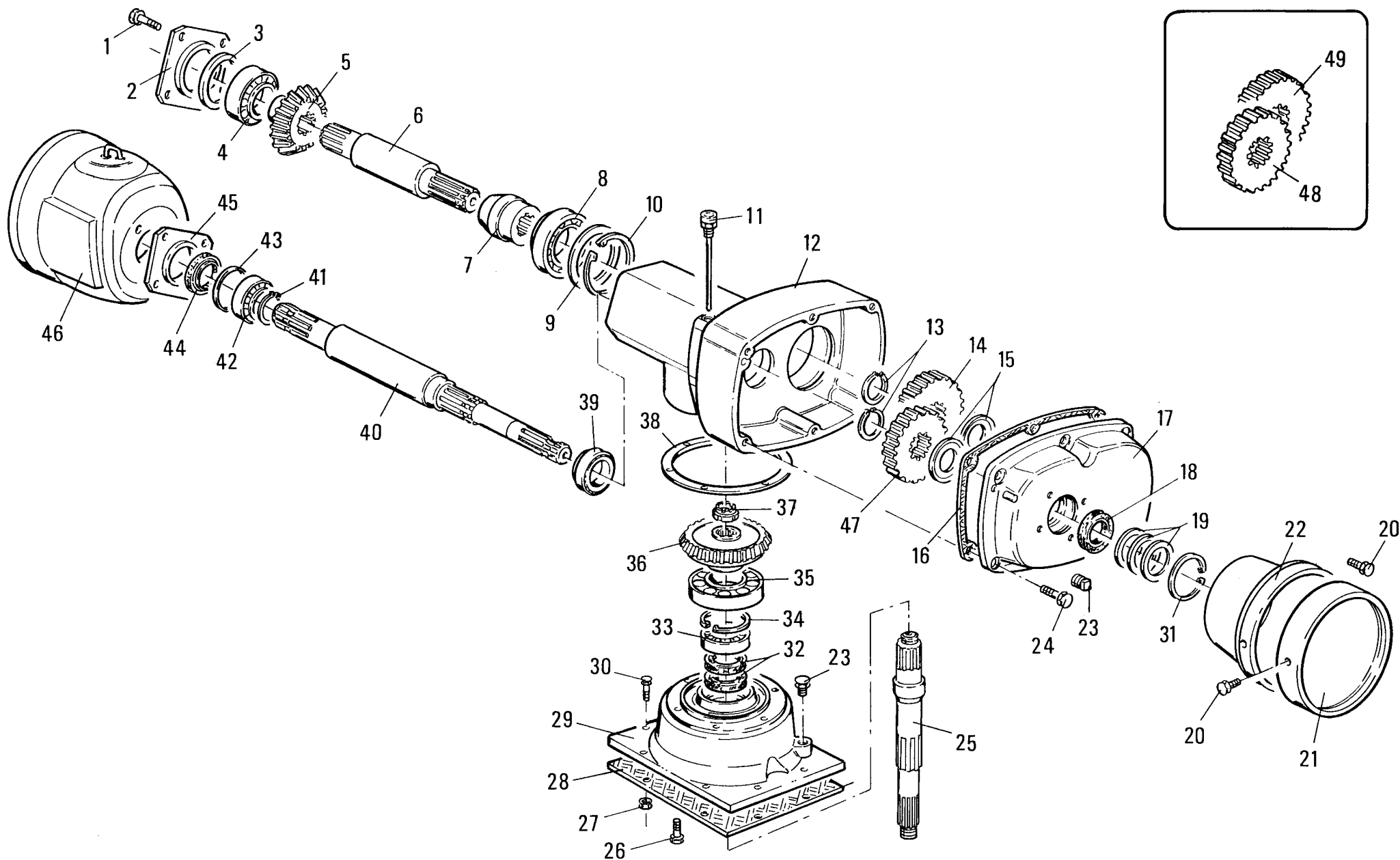

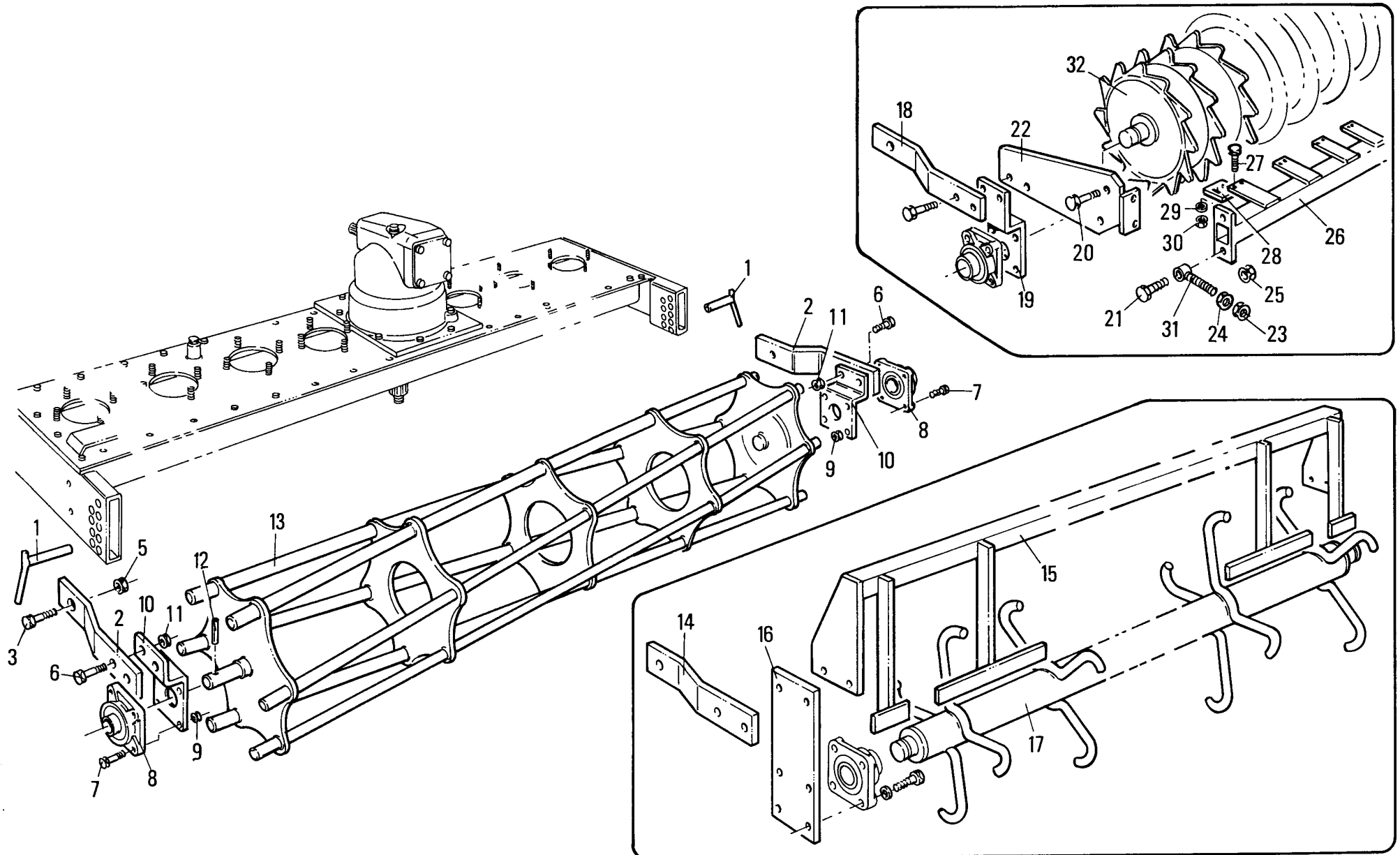

MURATORI ME12 - ME12C

TAV. 5.0

POS.	N° CODICE	Q	DESCRIZIONE	DESIGNATION	BENENNUNG	DESCRIPTION	DESIGNAZIONE	Da matr.	Fino matr
								De nr. serie Vom Seriennr. From serial nr.	Jusqu'au nr. serie Bis Seriennr. Up to serial nr.
1	68065900	2	PERNO	PIVOT	BOLZEN	PIN			
2	30145700	2	BRACCIO	BRAS	ARM	ARM			
3	60025900	2	VITE	VIS	SCHRAUBE	SCREW	TE 20 x 70 UNI 5737		
4									
5	62011400	2	DADO	ECROU	MUTTER	NUT	M 20 x 2,5 AUTOBLOCC.		
6	60006200	4	VITE	VIS	SCHRAUBE	SCREW	TE 14 x 55 UNI 5737		
7	60003400	8	VITE	VIS	SCHRAUBE	SCREW	TE 14 x 45 UNI 5737		
8	67009800	2	SUPPORTO	SUPPORT	TRAEGER	SUPPORT	UCF 207		
9	62010800	8	DADO	ECROU	MUTTER	NUT	M 14 x 2 AUTOBLOCC.		
10	30123600	2	STAFFA	BRIDE	BUEGEL	BRACKET			
11	62010800	4	DADO	ECROU	MUTTER	NUT	M 14 x 2 AUTOBLOCC.		
12	64001400	2	SPINA ELASTICA	GOUPILLE ELASTIQUE	SPANNSTIFT	ELASTIC PIN	8 x 50 UNI 6873		
13	42057900	1	RULLO GABBIA	ROULEAU CAGE	STABWALZE	CAGE ROLLER	200		
13	42058100	1	RULLO GABBIA	ROULEAU CAGE	STABWALZE	CAGE ROLLER	250		
13	42058200	1	RULLO GABBIA	ROULEAU CAGE	STABWALZE	CAGE ROLLER	300		
14	30145800	2	BRACCIO	BRAS	ARM	ARM	200		
14	30145900	2	BRACCIO	BRAS	ARM	ARM	250		
14	30145700	2	BRACCIO	BRAS	ARM	ARM	300		
15	40173300	1	TELAIO	CHASSIS	RAHMEN	FRAME	200		
15	40173500	1	TELAIO	CHASSIS	RAHMEN	FRAME	250		
15	40187400	1	TELAIO	CHASSIS	RAHMEN	FRAME	300		
16	30136600	2	STAFFA	BRIDE	BUEGEL	BRACKET			
17	42057200	1	RULLO PUNTONI	ROULEAU A POINTES	SPITZENWALZE	SPIKED ROLLER	200		
17	42057400	1	RULLO PUNTONI	ROULEAU A POINTES	SPITZENWALZE	SPIKED ROLLER	250		
17	42060100	1	RULLO PUNTONI	ROULEAU A POINTES	SPITZENWALZE	SPIKED ROLLER	300		
18	30145700	2	BRACCIO	BRAS	ARM	ARM			

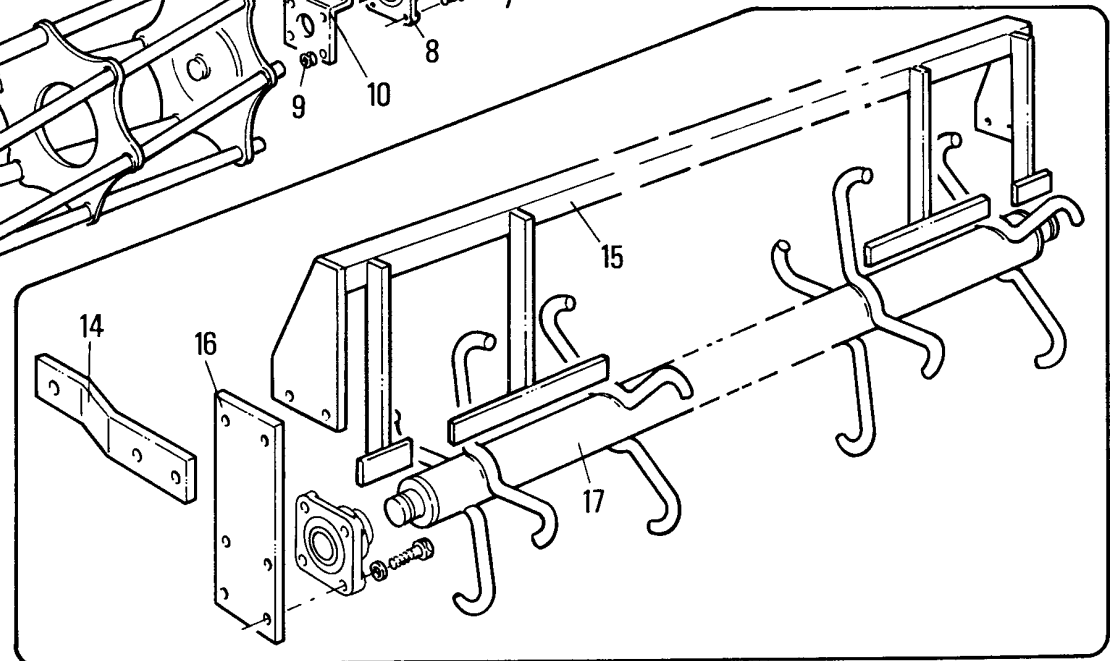
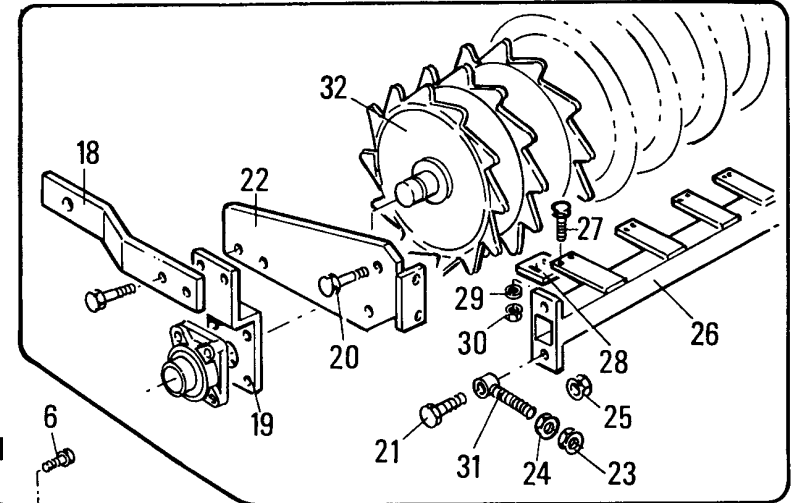
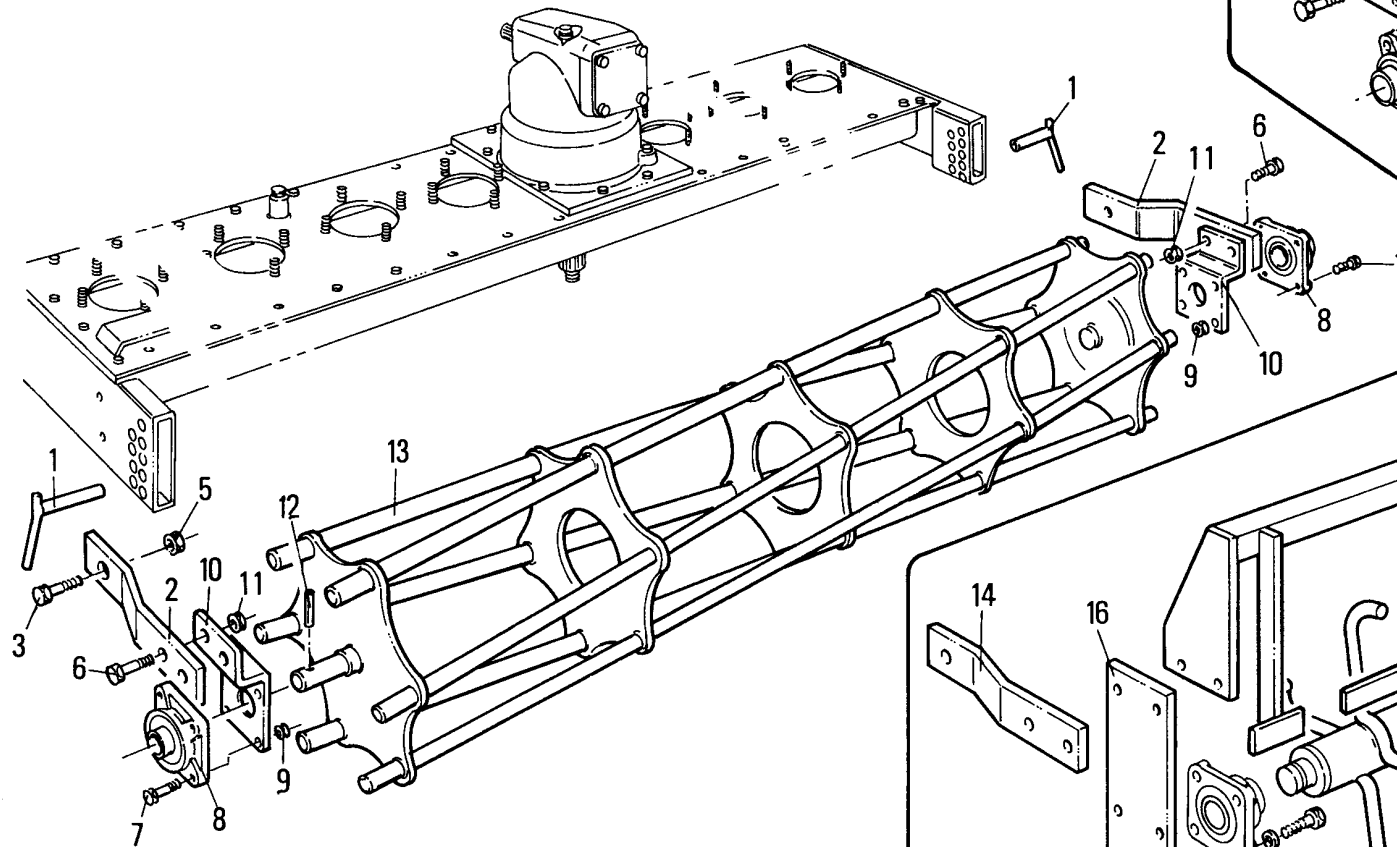

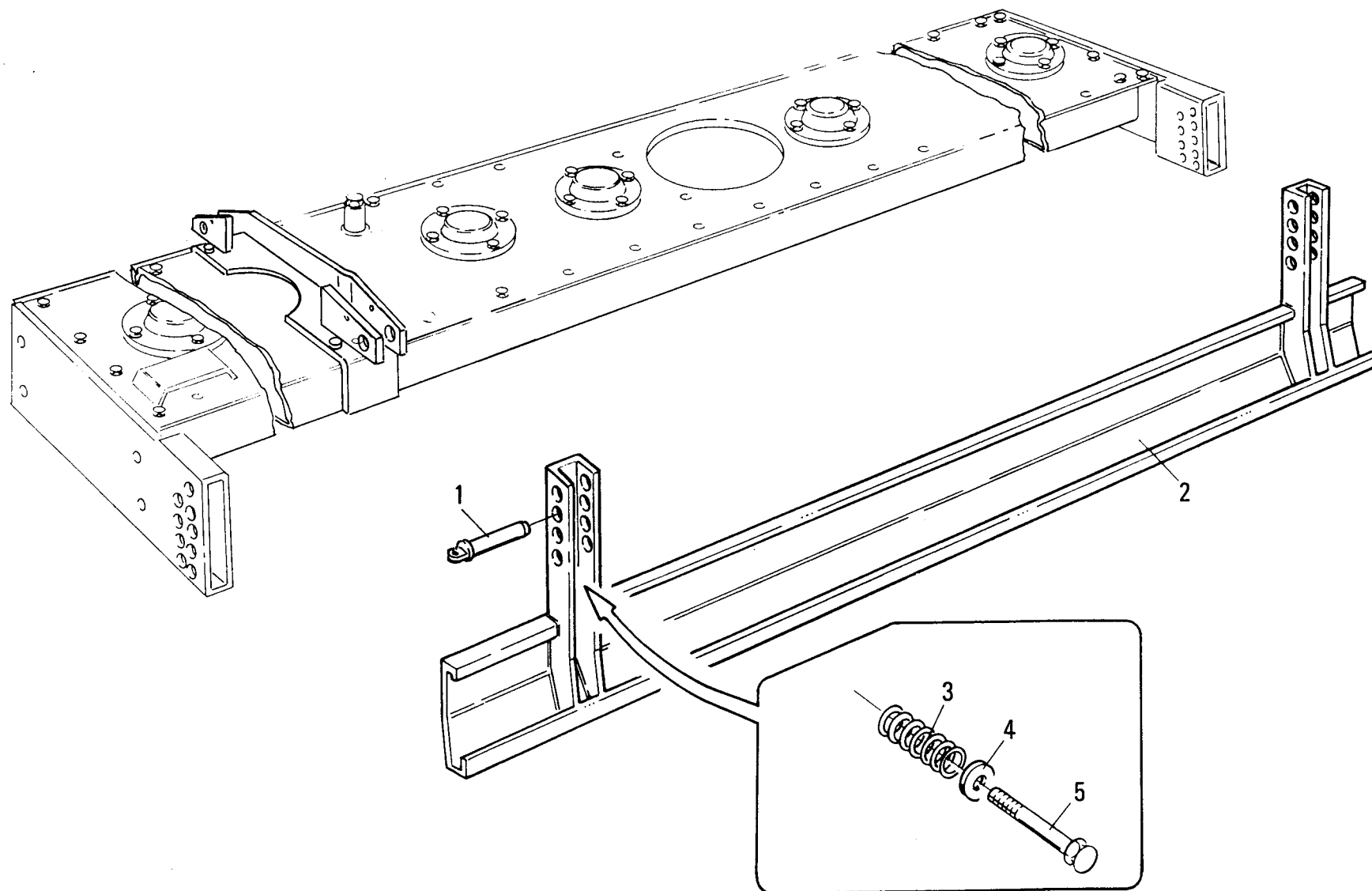

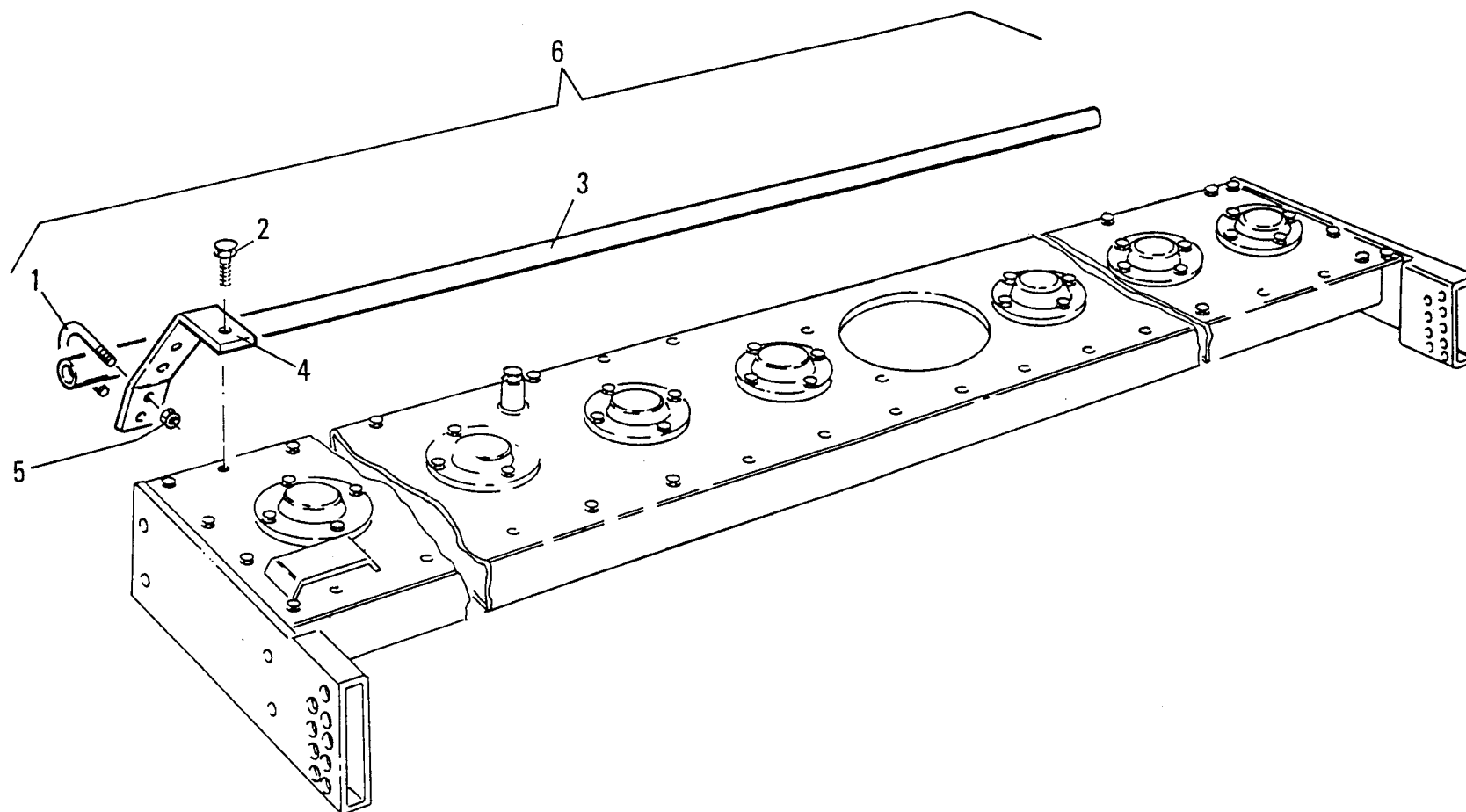

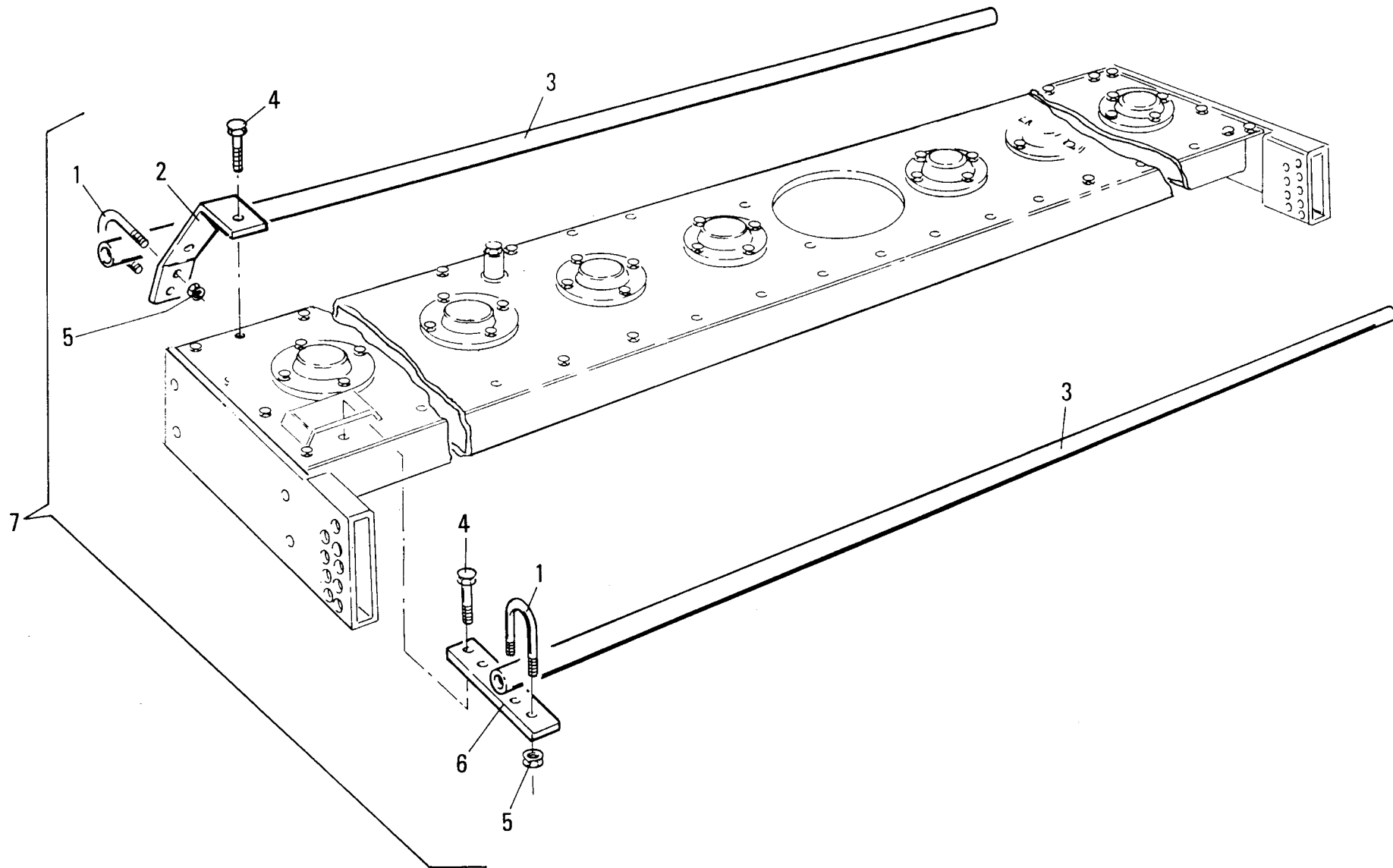

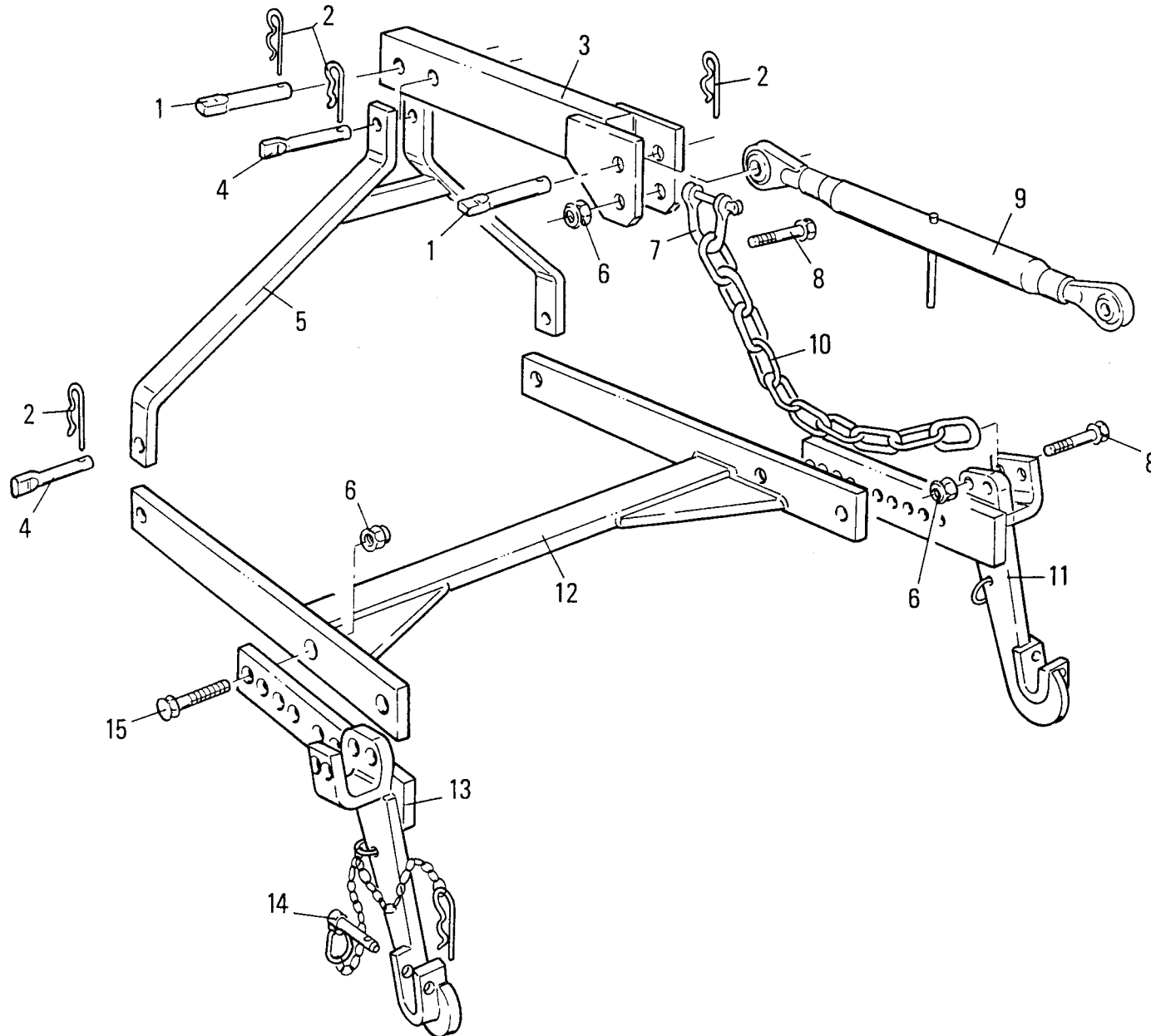

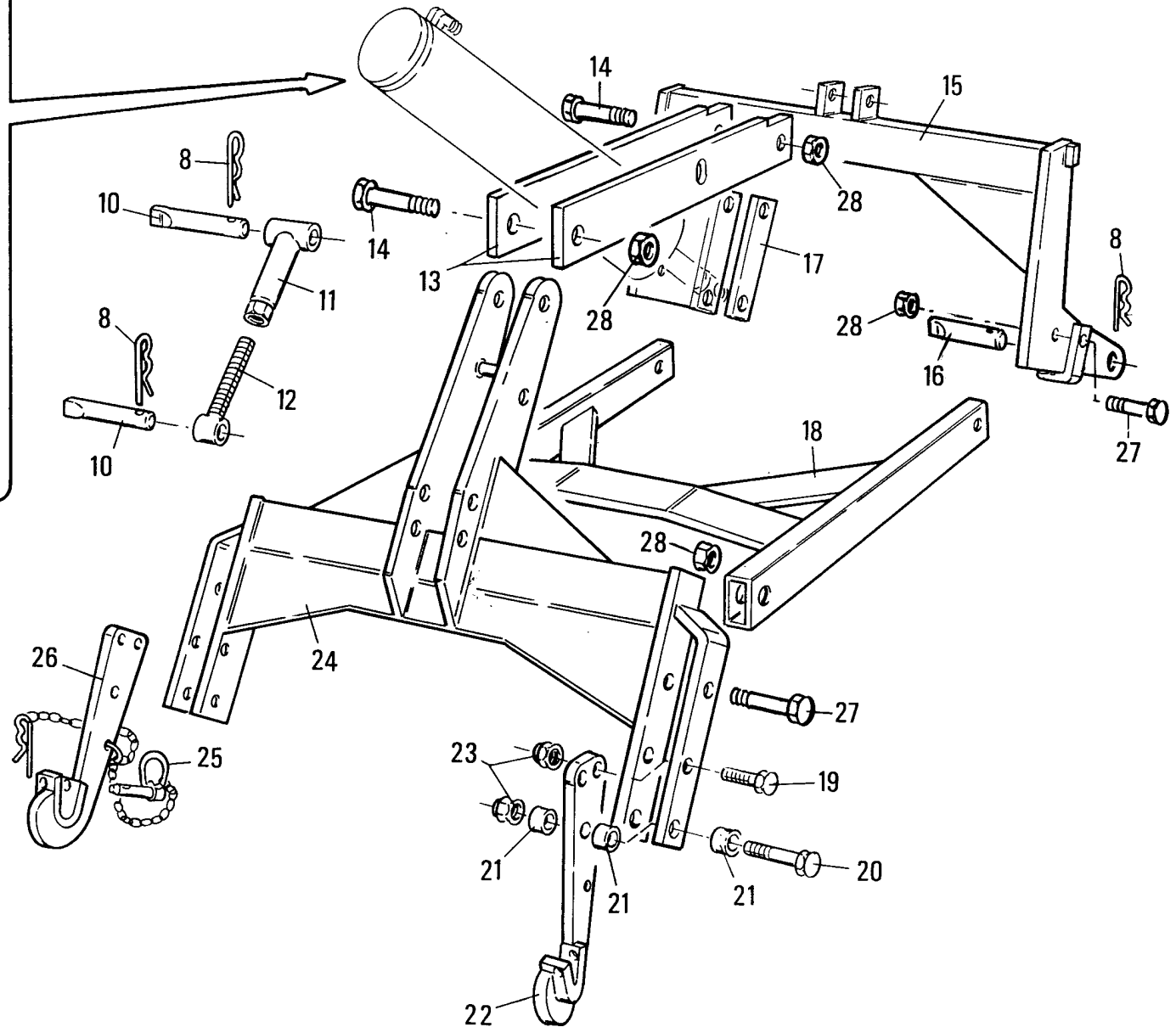
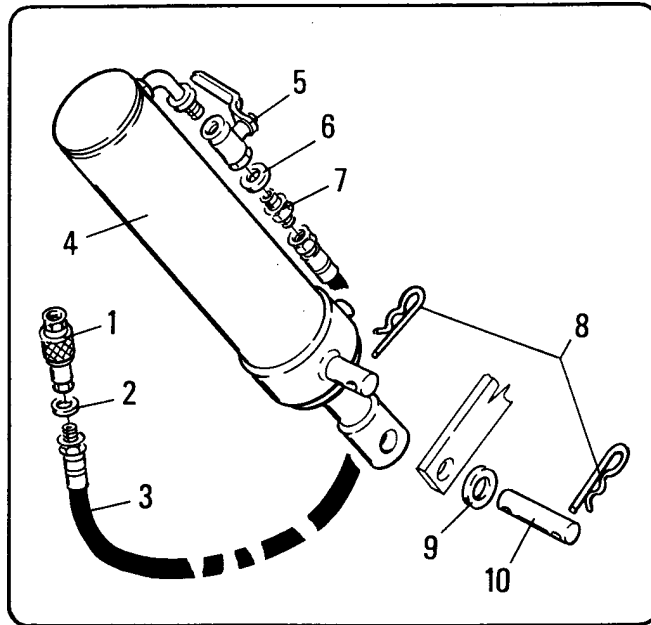

MURATORI ME12 - ME12C

TAV. 10.0

POS.	N° CODICE	Q	DESCRIZIONE	DESIGNATION	BENENNUNG	DESCRIPTION	DESIGNAZIONE	Da matr.	Fino matr
								De nr. serie	Jusqu'au nr. serie
								Vom Seriennr.	Bis Seriennr.
								From serial nr.	Up to serial nr.
1	68043500	1	ATTACCO RAPIDO	ATTELAGE RAPIDE	SCHNELLKUPPLUNG	QUICKLINKAGE			
2	61005700	1	RONDELLA	RONDELLE	SCHEIBE	WASHER	RAME 1/2"		
3	68077700	1	TUBO	TUBE	ROHR	TUBE			
4	68077300	1	CILINDRO	CYLINDRE	ZYLINDER	CYLINDER			
5	68077600	1	RUBINETTO	ROBINET	HAHN	TAP			
6	61005600	2	RONDELLA	RONDELLE	SCHEIBE	WASHER	RAME 3/8"		
7	68077500	1	NIPPLO	RACCORD	NIPPEL	NIPPLE	3/8"		
8	64001000	5	COPIGLIA	COUPILLE	SPLINT	COTTER PIN	AR Ø 5		
9	61003900	2	RONDELLA	RONDELLE	SCHEIBE	WASHER	PIANA 50 x 27 UNI 6592		
10	38022500	3	PERNO	PIVOT	BOLZEN	PIN	L= 115		
11	40205900	1	AGGANCIO	CROCHET	HAKEN	HOOK			
12	40205800	1	VITE	VIS	SCHRAUBE	SCREW			
13	30157800	2	TRAVE						
14	60033700	2	VITE	VIS	SCHRAUBE	SCREW	TE 24 x 180 UNI 5737		
15	40205500	1	TELAIO	CHASSIS	RAHMEN	FRAME			
16	38022400	2	PERNO	PIVOT	BOLZEN	PIN	L= 85		
17	30157700	2	TIRANTE	TIRANT	STANGE	TIEROD			
18	40205600	1	TELAIO	CHASSIS	RAHMEN	FRAME			
19	60035000	2	VITE	VIS	SCHRAUBE	SCREW	TE 18 x 50 UNI 5739		
20	60034900	2	VITE	VIS	SCHRAUBE	SCREW	TE 18 x 120 UNI 5737		
21	32155200	6	BOCCOLA	DOUILLE	BUECHSE	BUSHING			
22	40205300	1	STAFFA DX	BRIDE (D)	BUEGEL(RECHTS)	BRACKET (RH)			
23	62011200	4	DADO	ECROU	MUTTER	NUT	M 18 x 2,5 AUTOBLOCC.		
24	40205700	1	TELAIO	CHASSIS	RAHMEN	FRAME			
25	68077400	2	PERNO	PIVOT	BOLZEN	PIN			
26	40205400	1	STAFFA SX	BRIDE (G)	BUEGEL (LINKS)	BRACKET (LH)			

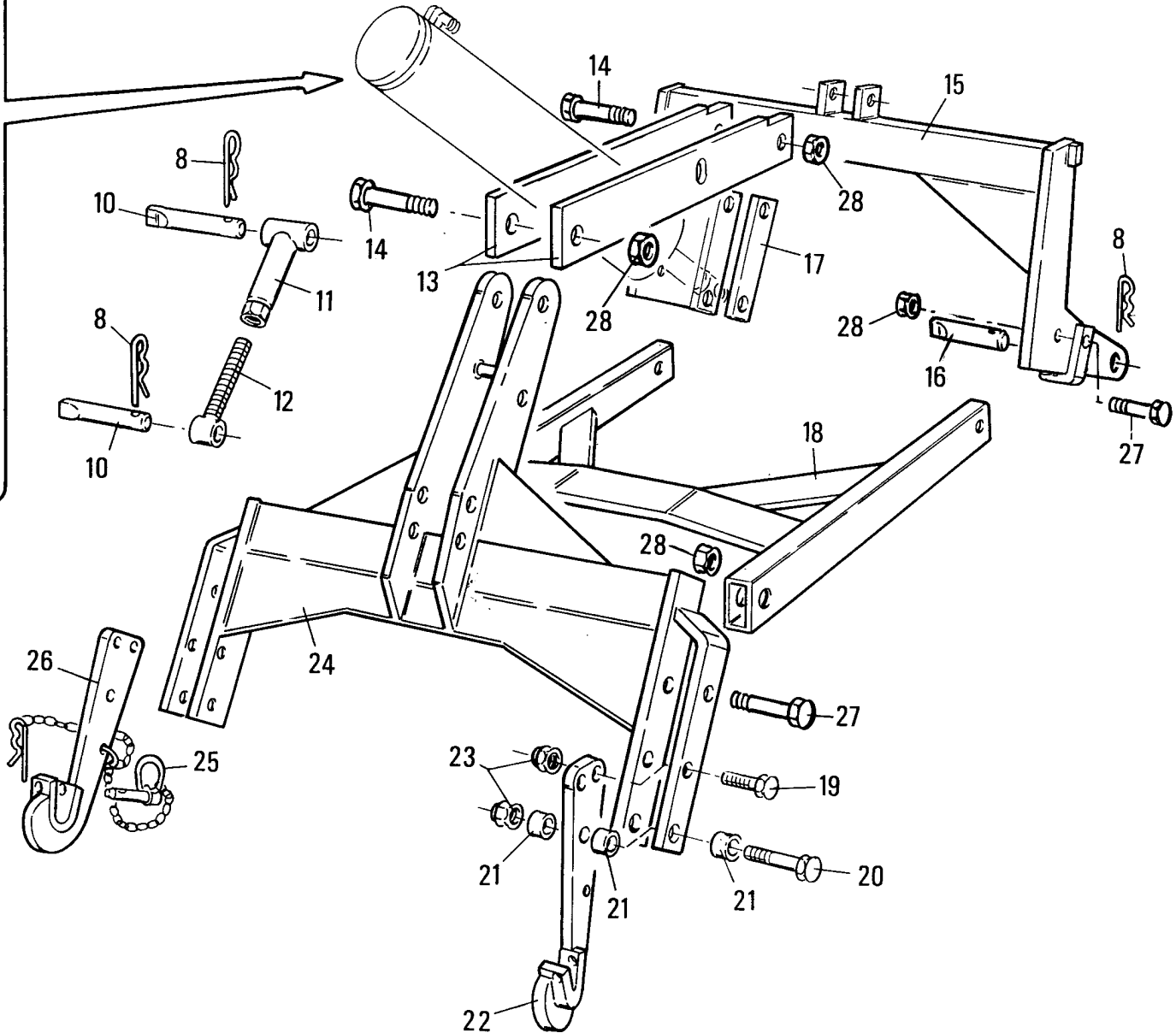
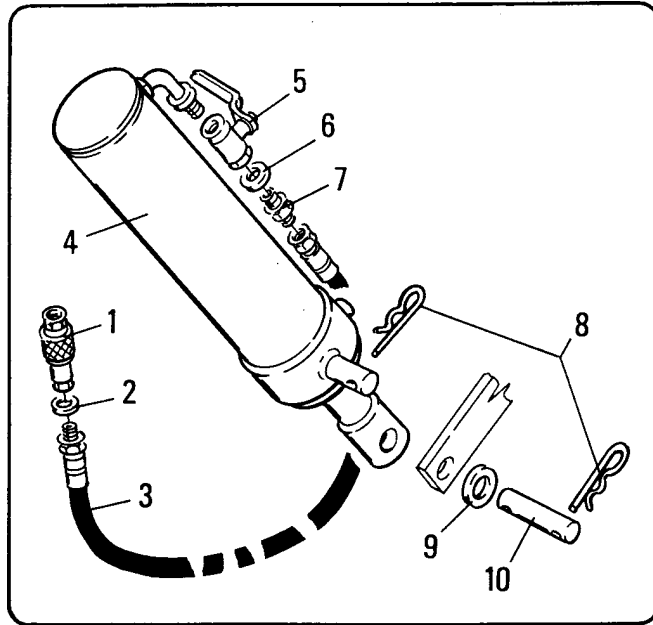

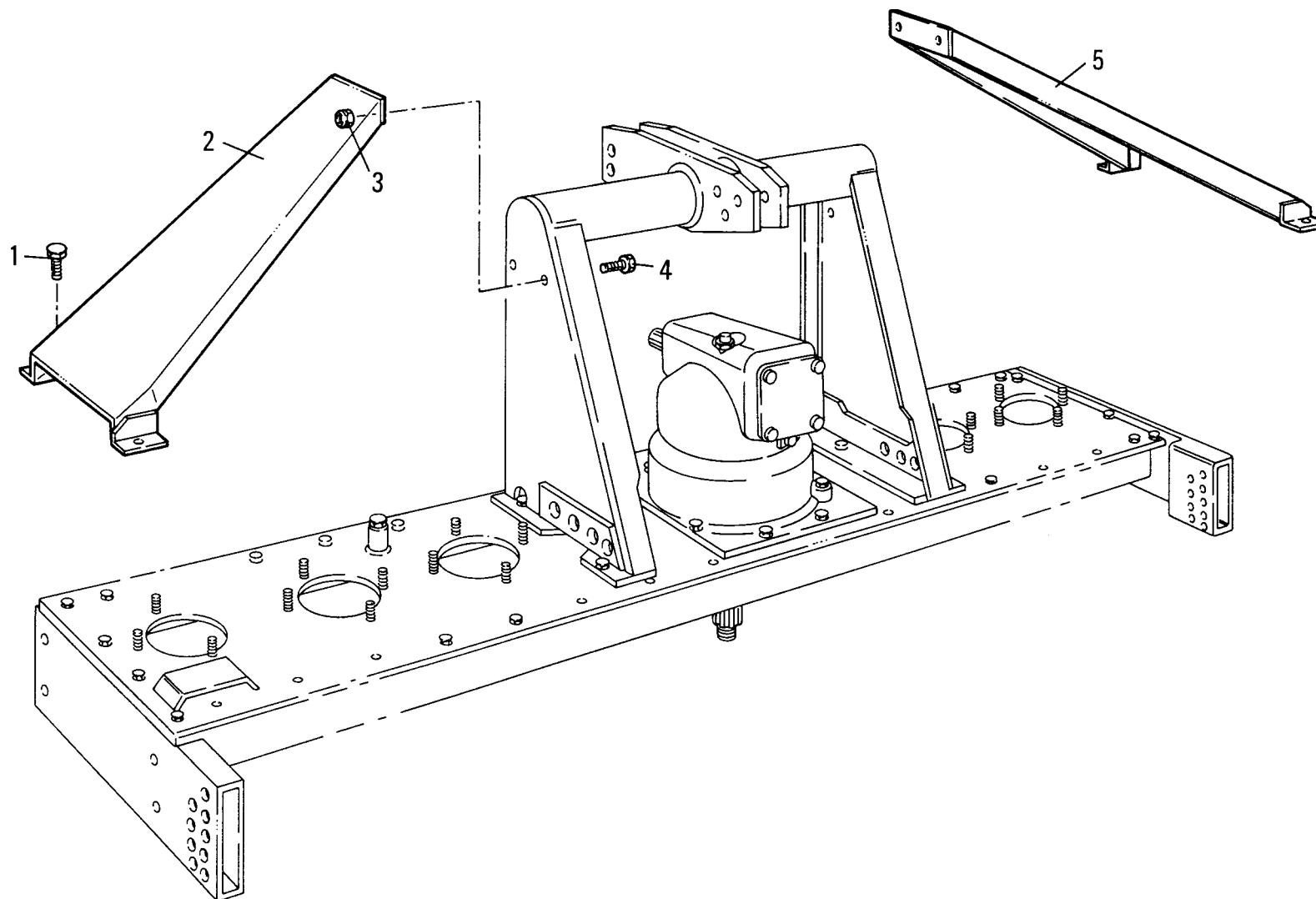

ZAPPATRICI - ERPICI ROTANTI - TRINCIATRICI

MURATORIM 

41051 CASTELNUOVO RANGONE (MODENA) Italy
Via Pavarello, 21 - 21/A-B-C -P.O.Box 45 -
Tel. ++39 059 535919 - Telefax ++39 059 537259
<http://www.muratoriequip.it>
e-mail: info@muratoriequip.it