

# MURATORINI

**TIPO-TYPE-TYP  
ME8 - ME8C**

**CATALOGO RICAMBI  
Catalogue Pièces Detachées  
Ersatzteilkatalog  
Spare Parts Catalogue  
Catálogo Recambios**

**EDIZIONE 10/2004**



Per ordinare parti di ricambio specificare:

- tipo e matricola della macchina (apposti sulla macchina o sui documenti di acquisto);
- numero del riferimento del pezzo nel disegno (Pos.), numero della tavola (Tav.) e numero di codice

**N.B.:** le indicazioni destro o sinistro vengono date guardando la macchina da dietro.

*Pour les commandes de pièces de rechange veuillez spécifier:*

- *type et numéro de série de la machine (indiqués sur la machine et sur le bon d'achat);*
- *numéro de référence du pièce sur le plan (Pos.), numéro du plan (Tav.) et numéro de code (codice)*

**N.B.:** *les indications droite ou gauche sont données en regardant la machine par derrière.*

*Zum Bestellen von Ersatzteilen folgendes angeben:*

- *Typ und Serien-Nr. der Maschine (zu finden auf der Maschine oder der Einkaufspapieren);*
- *Bezug-Nr. des Ersatzteils auf der Zeichnung (Pos.), Zeichnungsnummer (Tav.) und Kodenummer (codice)*

**N.B.:** *Die Angaben rechts und links verstehen sich so, dass man hinter der Maschine steht.*

When ordering spare parts specify:

- machine type and serial number (found on the machine or on the purchasing documents);
- reference number of the part on the relative drawing (Pos.), number of the drawing (Tav.) and part number (codice)

**N.B.:** right-hand or left-hand indications are made by viewing the machine from the rear.

**TAV. 4.0**

GRUPPO RIDUTTORE A 2 VELOCITA'  
ENSEMBLE BOITIER DEUX VITESSE  
SATZ FÜR ZWEIGANGGETRIEBE  
KIT FOR TWO-SPEED GEAR BOX

**TAV. 5.0**

GRUPPO RULLO POSTERIORE  
ENSEMBLE ROULEAU ARRIERE  
SATZ HINTERE WALZE  
KIT REAR ROLLER

**TAV. 6.0**

BARRA LIVELLATRICE POSTERIORE  
BARRE NIVELLEUSE ARRIERE  
HINTERE PLANIERSCHIENE  
REAR LEVELLING BAR

**TAV. 7.0**

PROTEZIONI ANTINFORTUNISTICHE "CE"  
PROTECTIONS "CE"  
UNFALLSCHUTZVORRICHTUNGEN "CE"  
SAFETY GUARDS "CE"

**TAV. 1.0 1/2**

GRUPPO TELAIO  
ENSEMBLE CHASSIS  
SATZ FÜR RAHMEN  
KIT FOR FRAME

**TAV. 1.0 2/2**

GRUPPO TELAIO (250)  
ENSEMBLE CHASSIS (250)  
SATZ FÜR RAHMEN (250)  
KIT FOR FRAME (250)

**TAV. 2.0**

GRUPPO ROTORI  
ENSEMBLE ROTORS  
SATZ FÜR ROTOREN  
KIT FOR ROTORS

**TAV. 3.0**

GRUPPO RIDUTTORE A 1 VELOCITA'  
ENSEMBLE BOITIER MONOVITESSE  
SATZ FÜR EINGANGGETRIEBE  
KIT FOR ONE-SPEED GEAR BOX

**TAV. 8.0**

PROTEZIONI ANTINFORTUNISTICHE "GB"  
PROTECTIONS "GB"  
UNFALLSCHUTZVORRICHTUNGEN "GB"  
SAFETY GUARDS "GB"

**TAV. 9.0**

ATTACCO POSTERIORE MECCANICO (250)  
ATTELAGE ARR. MECANIQUE (250)  
HINT. MECHANISCHES HITCH (250)  
REAR MECHANICAL HITCH (250)

**TAV. 10.0**

ATTACCO POSTERIORE IDRAULICO (250)  
ATTELAGE ARR. HYDRAULIQUE (250)  
HINT. HYDRAULISCHES HITCH (250)  
REAR HYDRAULIC HITCH (250)

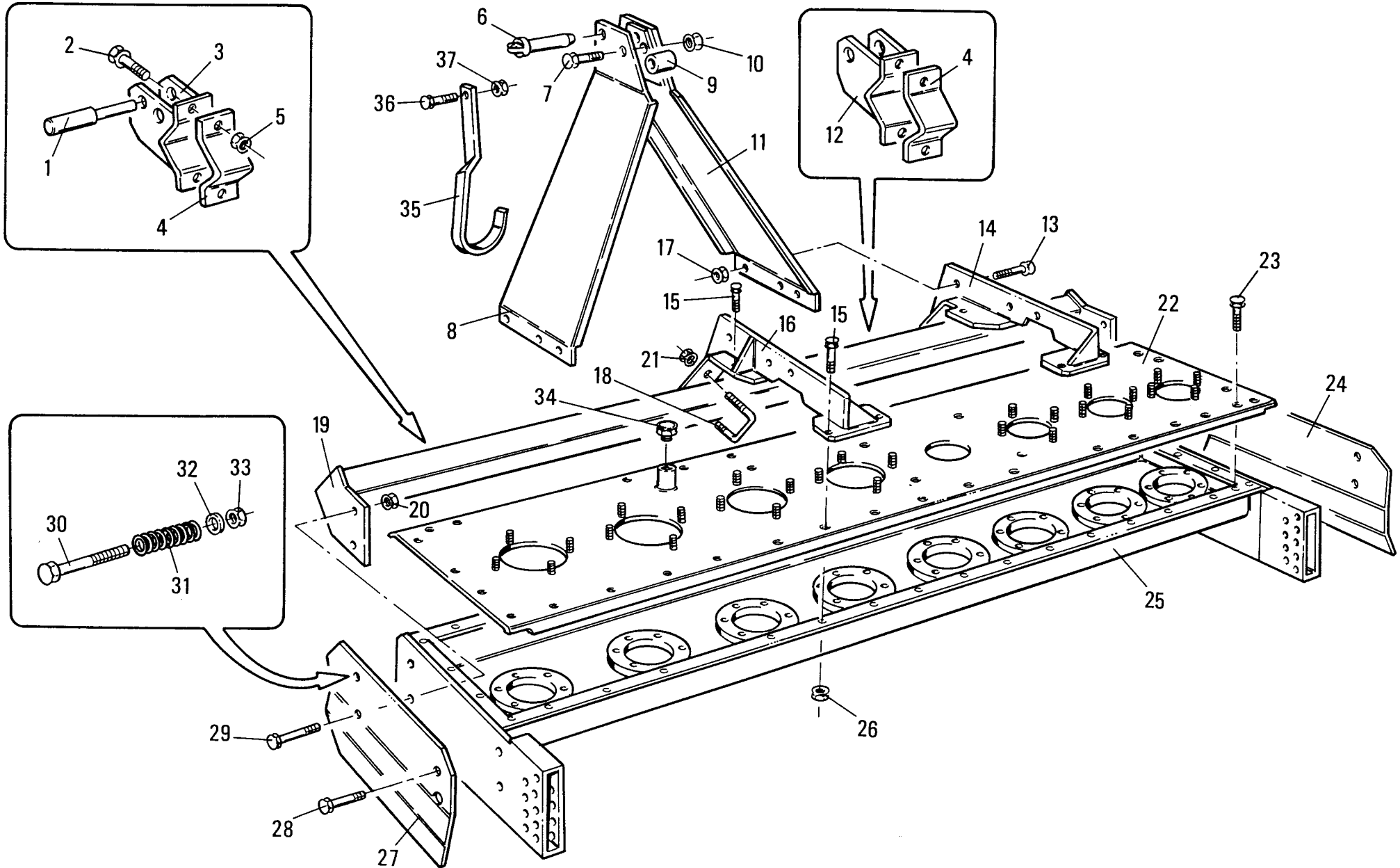

## MURATORI ME8 - ME8C

TAV. 1.0 1/2

POS.	N° CODICE	Q	DESCRIZIONE	DESIGNATION	BENENNUNG	DESCRIPTION	DESIGNAZIONE	Da matr.	Fino matr
								De nr. serie	Jusqu'au nr. serie
								Vom Seriennr.	Bis Seriennr.
								From serial nr.	Up to serial nr.
1	68062200	2	PERNO	PIVOT	BOLZEN	PIN			
2	60027100	4	VITE	VIS	SCHRAUBE	SCREW	TE 16 x 60 UNI 5737		
3	40131600	1	STAFFA SX	BRIDE (G)	BUEGEL (LINKS)	BRACKET (LH)			
4	30102300	2	RITEGNO	FIXAGE	BEFESTIGUNG	CLAMP			
5	62011000	4	DADO	ECROU	MUTTER	NUT	M 16 x 2 AUTOBLOCC.		
6	68062000	1	PERNO	PIVOT	BOLZEN	PIN			
7	60028600	1	VITE	VIS	SCHRAUBE	SCREW	TE 14 x 100 UNI 5737		
8	40154300	1	ARCATA SX	ARCADE (G)	ARKADE (LINKS)	ARCADE (LH)			
9	32069101	1	DISTANZIALE	ENTRETOISE	DISTANZSTUECCK	SPACER			
10	62010800	1	DADO	ECROU	MUTTER	NUT	TE 14 x 2 AUTOBLOCC.		
11	40154400	1	ARCATA DX	ARCADE (D)	ARKADE (RECHTS)	ARCADE (RH)			
12	40133800	1	STAFFA DX	BRIDE (D)	BUEGEL (RECHTS)	BRACKET (RH)			
13	60023200	6	VITE	VIS	SCHRAUBE	SCREW	TE 14 x 35 UNI 5735		
14	40189200	1	MONTANTE DX	MONTANT	SAEULE	PILLAR			
15	60033700	8	VITE	VIS	SCHRAUBE	SCREW	TE 10 x 35 UNI 5740		
16	40189300	1	MONTANTE SX	MONTANT	SAEULE	PILLAR			
17	62010800	6	DADO	ECROU	MUTTER	NUT	M 14 x 2 AUTOBLOCC.		
18	38017300	2	CAVALLOTTO	ARRETOIR	KLEMMSTUECK	UBOLT			
19	40189400	1	BARRA	BARRE	STANGE	BAR	150		
19	40189500	1	BARRA	BARRE	STANGE	BAR	175		
19	40189600	1	BARRA	BARRE	STANGE	BAR	200		
19	40189700	1	BARRA	BARRE	STANGE	BAR	225		
19	40189800	1	BARRA	BARRE	STANGE	BAR	250		
20	62010800	2	DADO	ECROU	MUTTER	NUT	M 14 x 2 AUTOBLOCC.		
21	62010400	4	DADO	ECROU	MUTTER	NUT	M 10 x 1,5 AUTOBLOCC.		
22	40149000	1	COPERCHIO	COUVERCLE	DECKEL	COVER	150		60594

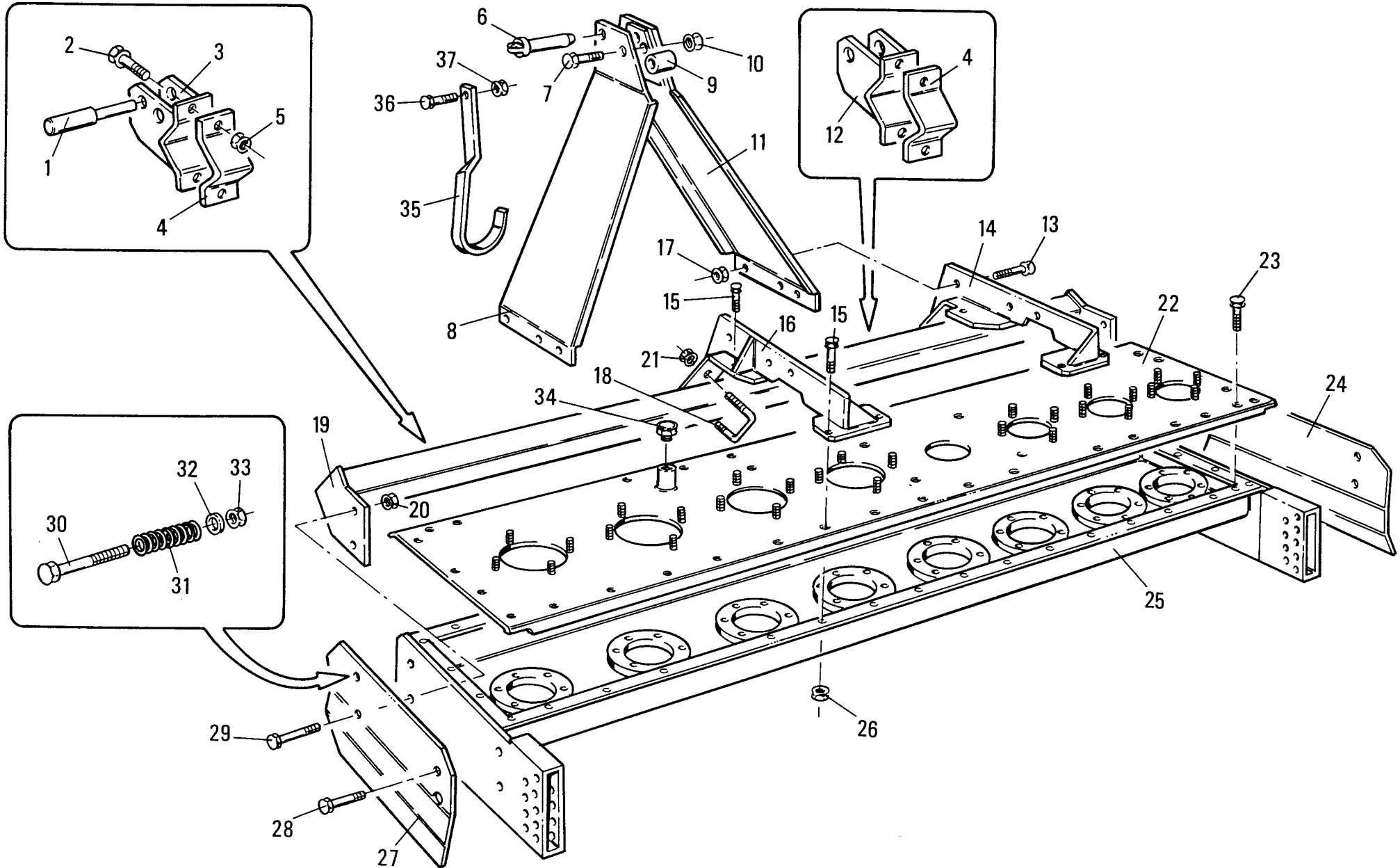

## MURATORI ME8 - ME8C

TAV. 1.0 1/2

POS.	N° CODICE	Q	DESCRIZIONE	DESIGNATION	BENENNUNG	DESCRIPTION	DESIGNAZIONE	Da matr.	Fino matr.
								De nr. serie Vom Seriennr. From serial nr.	Jusqu'au nr. serie Bis Seriennr. Up to serial nr.
22	40149100	1	COPERCHIO	COUVERCLE	DECKEL	COVER	175		60594
22	40149200	1	COPERCHIO	COUVERCLE	DECKEL	COVER	200		60594
22	40149300	1	COPERCHIO	COUVERCLE	DECKEL	COVER	225		60594
22	40149400	1	COPERCHIO	COUVERCLE	DECKEL	COVER	250		60594
22	40217700	1	COPERCHIO	COUVERCLE	DECKEL	COVER	125	60595	
22	40217800	1	COPERCHIO	COUVERCLE	DECKEL	COVER	150	60595	
22	40217900	1	COPERCHIO	COUVERCLE	DECKEL	COVER	175	60595	
22	40218000	1	COPERCHIO	COUVERCLE	DECKEL	COVER	200	60595	
22	40218100	1	COPERCHIO	COUVERCLE	DECKEL	COVER	225	60595	
22	40218200	1	COPERCHIO	COUVERCLE	DECKEL	COVER	250	60595	
23	60028000		VITE	VIS	SCHRAUBE	SCREW	TE 10x1,25x25 UNI 5740		
24	39194200	1	FIANCO	FLANC	SEITENWAND	SIDE FRAME			
25	40184200	1	CASSA	CAISSE	WANNE	GEARCASE	150		60594
25	40184300	1	CASSA	CAISSE	WANNE	GEARCASE	175		60594
25	40184400	1	CASSA	CAISSE	WANNE	GEARCASE	200		60594
25	40184500	1	CASSA	CAISSE	WANNE	GEARCASE	225		60594
25	40184600	1	CASSA	CAISSE	WANNE	GEARCASE	250		60594
25	40217000	1	CASSA	CAISSE	WANNE	GEARCASE	125	60595	
25	40217100	1	CASSA	CAISSE	WANNE	GEARCASE	150	60595	
25	40217200	1	CASSA	CAISSE	WANNE	GEARCASE	175	60595	
25	40217300	1	CASSA	CAISSE	WANNE	GEARCASE	200	60595	
25	40217400	1	CASSA	CAISSE	WANNE	GEARCASE	225	60595	
25	40217500	1	CASSA	CAISSE	WANNE	GEARCASE	250	60595	
26	62010300		DADO	ECROU	MUTTER	NUT	M 10 x 1,25 AUTOBLOCC.		
27	39194100	1	FIANCO	FLANC	SEITENWAND	SIDE FRAME			
28	60023400	2	VITE	VIS	SCHRAUBE	SCREW	TE 14 x 90 UNI 5737		

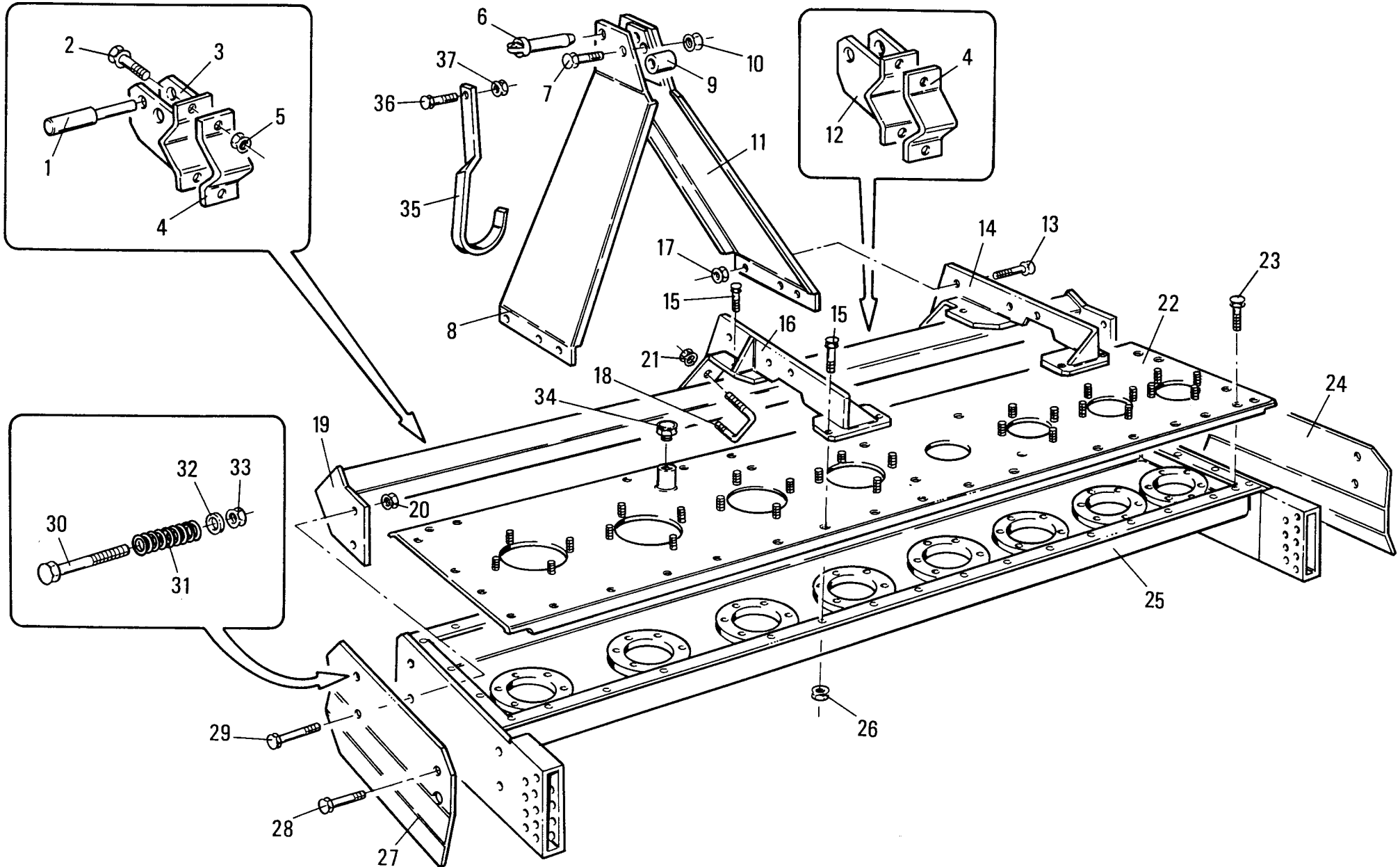



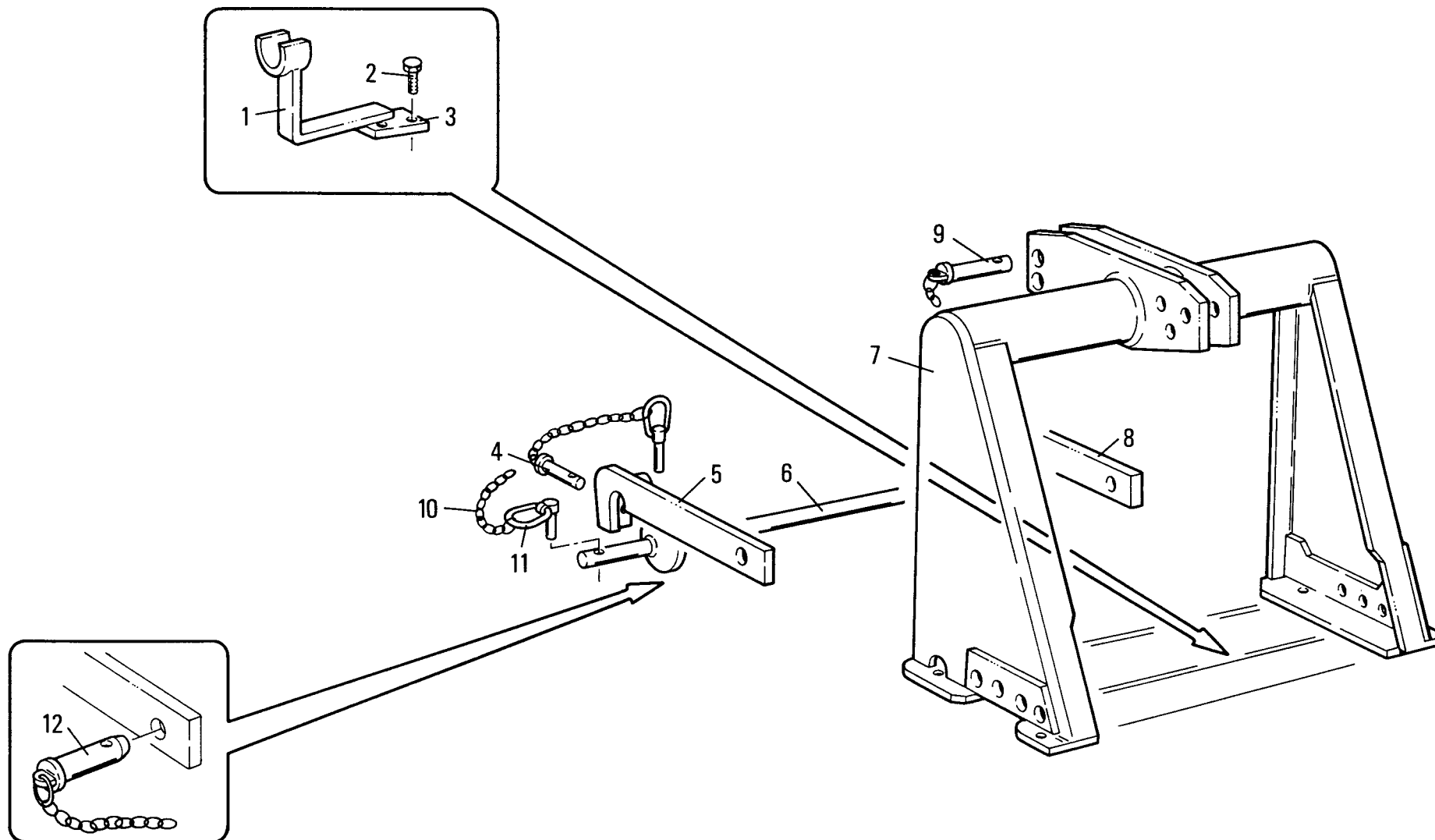





## MURATORI ME8 - ME8C

## TAV. 2.0

POS.	N° CODICE Q	DESCRIZIONE	DESIGNATION	BENENNUNG	DESCRIPTION	DESIGNAZIONE	Da matr.	Fino matr
							De nr. serie Vom Seriennr. From serial nr.	Jusqu'au nr. serie Bis Seriennr. Up to serial nr.
1	62010300	DADO	ECROU	MUTTER	NUT	M 10 x 1,25 AUTOBLOCC.		
2	10033000	SUPPORTO	SUPPORT	TRAEGER	SUPPORT			79572
2	10042900	SUPPORTO	SUPPORT	TRAEGER	SUPPORT		79573	
3	80014700	GUARNIZIONE	GARNITURE	DICHTUNG	SEAL			
4	67012500	CUSCINETTO	ROULEMENT	LAGER	BEARING	6007 2RS1		79572
4	67018500	CUSCINETTO	ROULEMENT	LAGER	BEARING	6007	79573	
5	63005200	ANELLO ELASTICO	ARRETOIR	SPANNRING	SNAP-RING	Ø 62 DIN 472		
6	39196300	PROTEZIONE	PROTECTION	SCHUTZ	GUARD			
7	62013700	GHIERA	FRETTE	NUTMUTTER	RING NUT	M 40 x 1,5 AUTOBLOCC.		
8	32120600	SPESSORE	EPAISSEUR	DICKE	THICKNESS			
9	10032800	INGRANAGGIO LATERALE	ENGRANAGE LAT.	ZAHNRAD (SEITL.)	SIDE GEAR			
10	63005300	ANELLO ELASTICO	ARRETOIR	SPANNRING	SNAP-RING	Ø 85 DIN 472		
11	67004800	CUSCINETTO	ROULEMENT	LAGER	BEARING	6209		
12	66015100	ANELLO TENUTA	JOINT D'ETANCHEITE	DICHTUNGSRING	JUNT RING	60 x 75 x 8		
13	80014600	GUARNIZIONE	GARNITURE	DICHTUNG	SEAL			
14	10033101	SUPPORTO	SUPPORT	TRAEGER	SUPPORT			
15	60019700	VITE	VIS	SCHRAUBE	SCREW	TE 12x1,5x30 UNI 5740		
16	68075100	FELTRO	FEUTRE	FILZ	FELT			
17	64004300	INGRASSATORE	GRAISSEUR	SCHMIERNIPPEL	GREASE FITTING	M 12 x 1,75	79573	
18	45100500	ROTORE	ROTOR	ROTOR	ROTOR			
19	60025100	VITE	VIS	SCHRAUBE	SCREW	TE 16x1,5x50 UNI 5740		
20	62010900	DADO	ECROU	MUTTER	NUT	M 16 x 1,5 AUTOBLOCC.		
21	12016500	LAMA SX	COUTEAU G.	L. MESSER	LH. BLADE			
22	12016400	LAMA DX	COUTEAU D.	R. MESSER	RH. BLADE			
23	10032700	1	INGRANAGGIO CENTRALE	ENGRANAGE CENTR.	ZAHNRAD (ZENTR.)	CENTRAL GEAR		
24	32120400	1	DISTANZIALE	ENTRETOISE	DISTANZSTUECCK	SPACER		

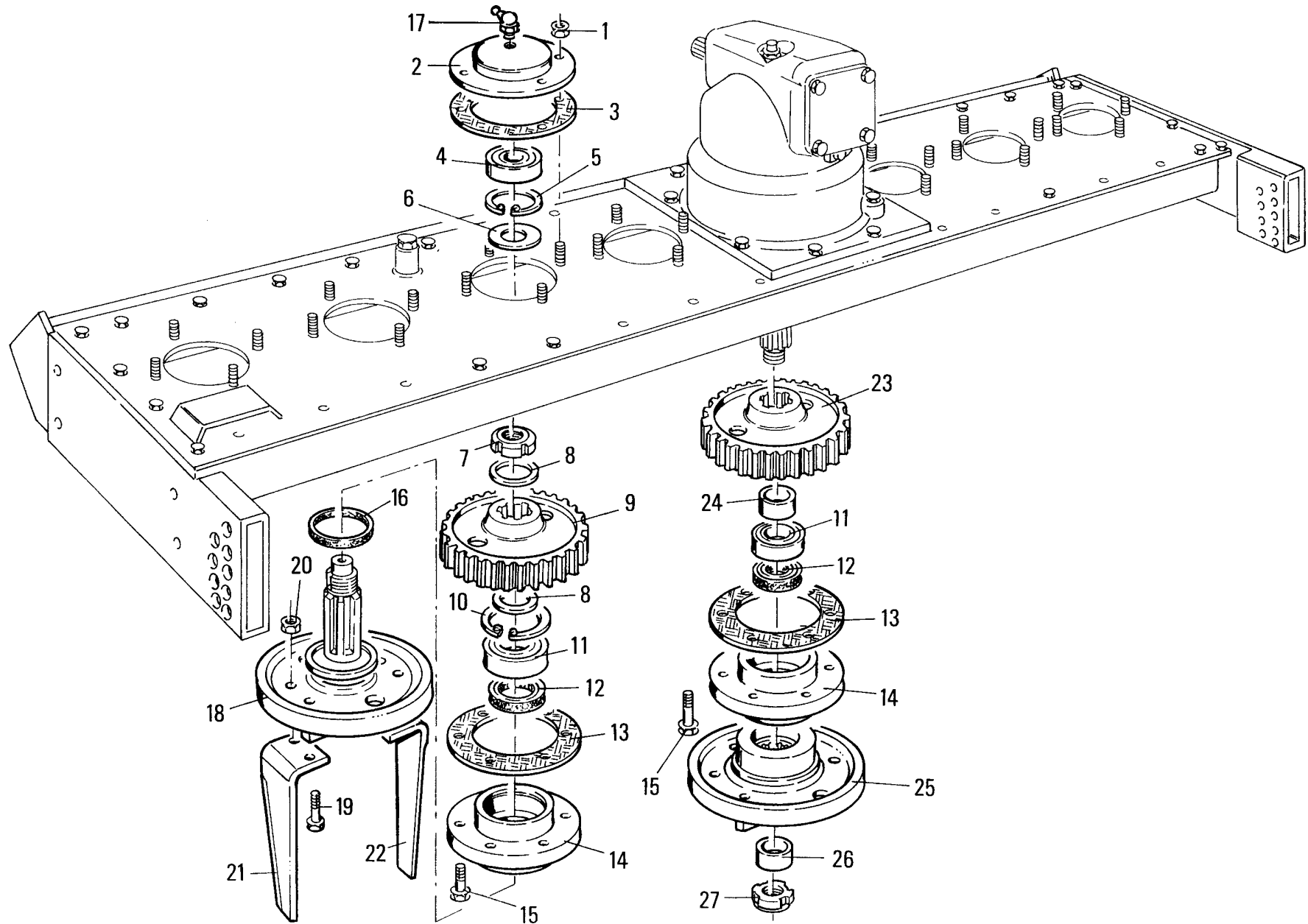



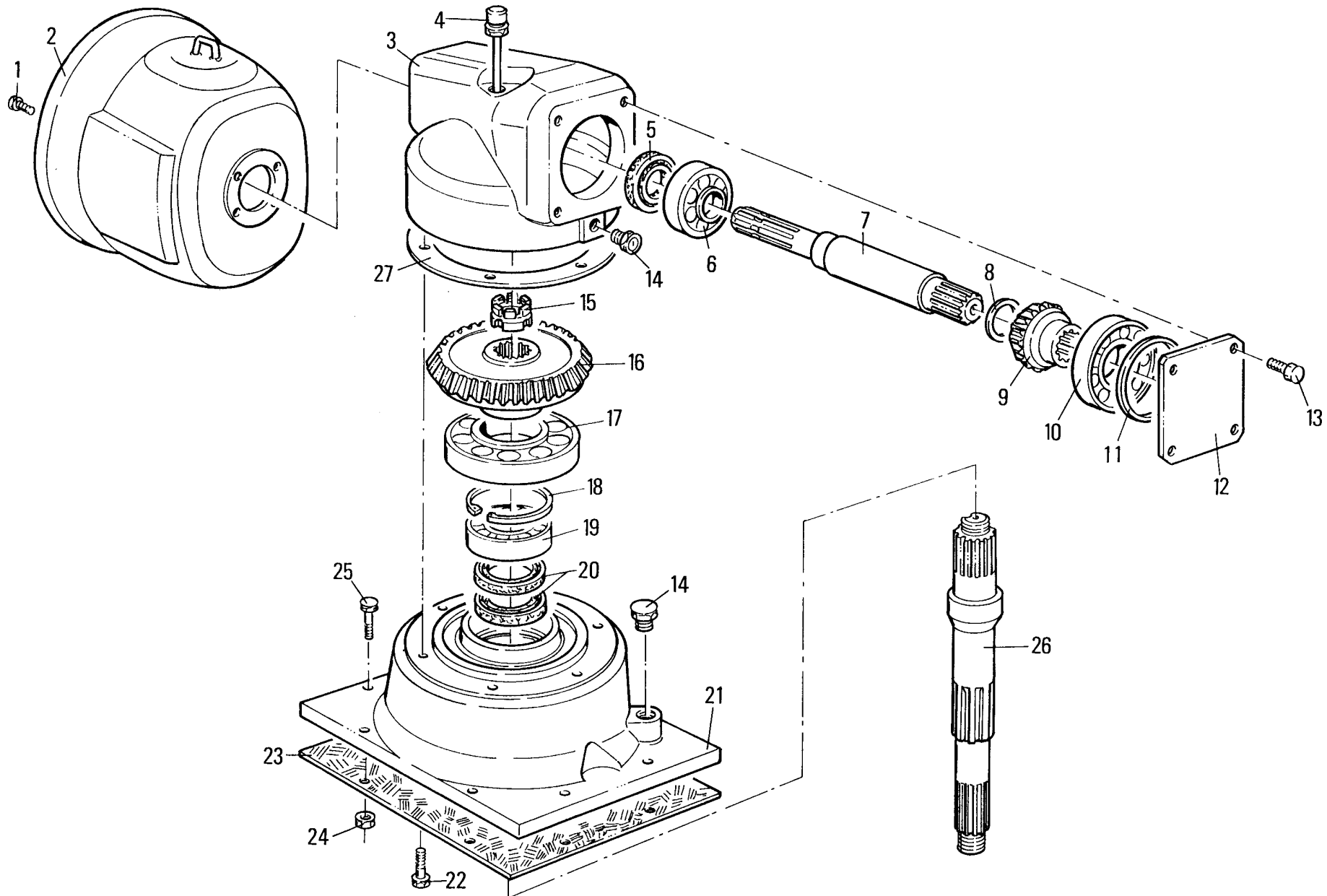

**MURATORI ME8**
**TAV. 3.0**

POS.	N° CODICE	Q	DESCRIZIONE	DESIGNATION	BENENNUNG	DESCRIPTION	DESIGNAZIONE	Da matr.	Fino matr
								De nr. serie Vom Seriennr.	Jusqu'au nr. serie Bis Seriennr.
								From serial nr.	Up to serial nr.
1	60021600	4	VITE	VIS	SCHRAUBE	SCREW	TE 10x1,5x20 UNI 5739		
2	68077000	1	PROTEZIONE	PROTECTION	SCHUTZ	GUARD			
3	01016400	1	SCATOLA	CARTER	GEHAEUSE	GEARBOX			
4	68078700	1	TAPPO	BOUCHON	STOPFEN	PLUG			
5	66015700	1	ANELLO TENUTA	JOINT D'ETANCHEITE	DICHTUNGSRING	JUNT RING			
6	67005500	1	CUSCINETTO	ROULEMENT	LAGER	BEARING	32207		
7	31071700	1	ALBERO	ARBRE	WELLE	SHAFT			
8	68078900		SPESSORE	EPAISSEUR	DICKE	THICKNESS	50 x 40		
9	10038600	1	PIGNONE CONICO	PIGNON CONIQUE	KEGELRITZEL	BEVEL PINION	Z= 14		
10	67009600	1	CUSCINETTO	ROULEMENT	LAGER	BEARING	30212		
11	68079000		SPESSORE	EPAISSEUR	DICKE	THICKNESS	110 x 95		
12	01016600	1	COPERCHIO	COUVERCLE	DECKEL	COVER			
13	60017900	4	VITE	VIS	SCHRAUBE	SCREW	TE 10 x 25 UNI 5739		
14	68078800	2	TAPPO	BOUCHON	STOPFEN	PLUG	M 16 x 1,5		
15	62014200	1	GHIERA	FRETTE	NUTMUTTER	RING NUT	M 40 x 1,5 CON COLLARE		
16	10038700	1	CORONA CONICA	COURONNE CONIQUE	KEGELKRANZ	RING BEVEL	Z= 25		
17	67001600	1	CUSCINETTO	ROULEMENT	LAGER	BEARING	30214		
18	63000100	1	ANELLO ELASTICO	ARRETOIR	SPANNRING	SNAP-RING	Ø 90 I UNI 7437		
19	67009400	1	CUSCINETTO	ROULEMENT	LAGER	BEARING	30210		
20	66015800	2	ANELLO TENUTA	JOINT D'ETANCHEITE	DICHTUNGSRING	JUNT RING			
21	01016500	1	SUPPORTO	SUPPORT	TRAEGER	SUPPORT			
22	60021200	8	VITE	VIS	SCHRAUBE	SCREW	TE 12 x 35 UNI 5739		
23	80014800	1	GUARNIZIONE	GARNITURE	DICHTUNG	SEAL			
24	62010300	4	DADO	ECROU	MUTTER	NUT	M 10 x 1,25 AUTOBLOCC.		
25	60033700	8	VITE	VIS	SCHRAUBE	SCREW	TE 10x1,25x35 UNI 5740		
26	31071800	1	ALBERO	ARBRE	WELLE	SHAFT			

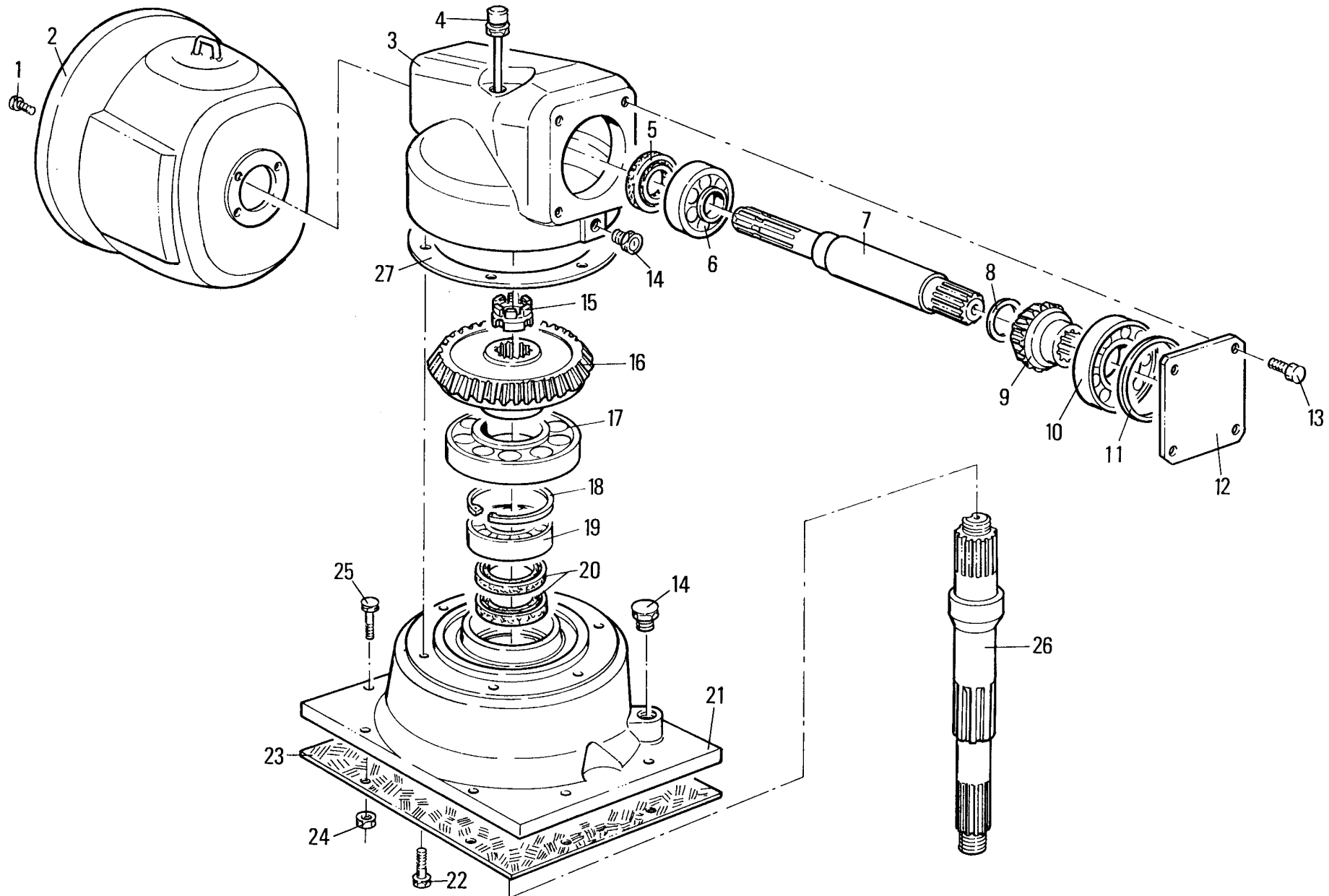



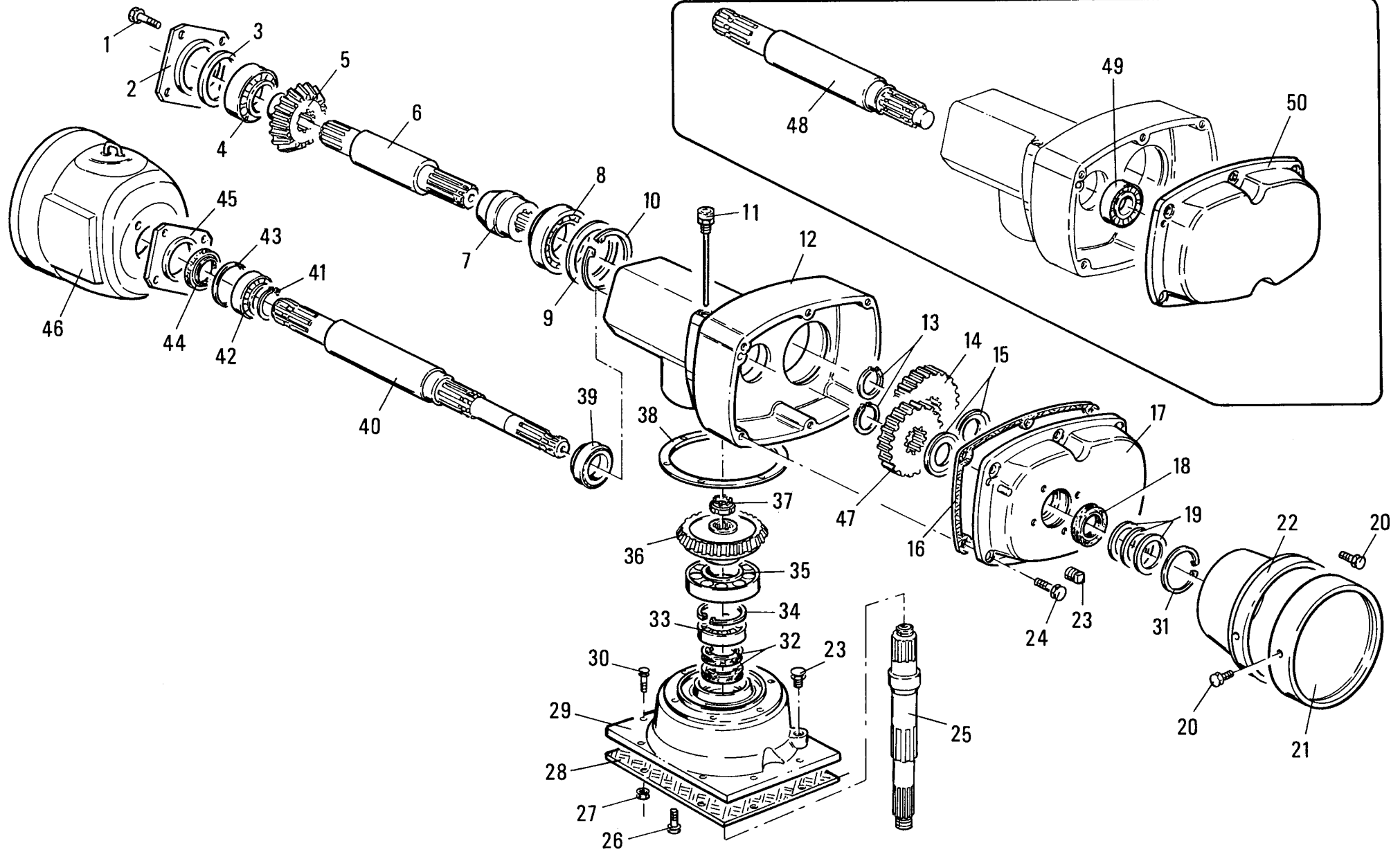

## MURATORI ME8C

TAV. 4.0

POS.	N° CODICE	Q	DESCRIZIONE	DESIGNATION	BENENNUNG	DESCRIPTION	DESIGNAZIONE	Da matr. De nr. serie Vom Seriennr. From serial nr.	Fino matr. Jusqu'au nr. serie Bis Seriennr. Up to serial nr.
<b>I codici con asterisco sono stati utilizzati solo sulle seguenti matricole oltre a quello riportato in tabella:</b>							<b>60583 - 56396 - 56397 - 56398 - 56399</b>		
<i>Les codes avec étoile ont été seulement utilisés sur les numéros de série suivantes:</i>									
<b>Koden mit sternchen wurden nur auf folgenden seriennummer benutzt:</b>									
<i>Codes with (*) have been utilized only on following serial numbers:</i>									
1	60021300	8	VITE	VIS	SCHRAUBE	SCREW	TE 10x30 UNI 5739		
2	01016800	1	COPERCHIO	COUVERCLE	DECKEL	COVER			
3	68079000		SPESSORE	EPAISSEUR	DICKE	THICKNESS			
4	67009600	1	CUSCINETTO	ROULEMENT	LAGER	BEARING	30212		
5	10038600	1	PIGNONE CONICO	PIGNON CONIQUE	KEGELRITZEL	BEVEL PINION			
6	31071900	1	ALBERO	ARBRE	WELLE	SHAFT			
7	32157800	1	BOCCOLA	DOUILLE	BUECHSE	BUSHING			
8	67009600	1	CUSCINETTO	ROULEMENT	LAGER	BEARING	30212		
9	68079000		SPESSORE	EPAISSEUR	DICKE	THICKNESS	110x95		
10	63002800	1	ANELLO ELASTICO	ARRETOIR	SPANNRING	SNAP-RING	Ø 110 I UNI 7437		
11	68080100	1	TAPPO	BOUCHON	STOPFEN	PLUG			
12	01016700	1	SCATOLA	CARTER	GEHAEUSE	GEARBOX			
13	63005800	2	ANELLO ELASTICO	ARRETOIR	SPANNRING	SNAP-RING	Ø 39 E UNI 7435		
14	31072200	1	INGRANAGGIO	PIGNON	ZAHNRAD	GEAR	Z 19		
15	68080200	2	MOLLA RITEGNO	RESSORT	FEDER	SPRING			
16	80015100	1	GUARNIZIONE	GARNITURE	DICHTUNG	SEAL			
17	03002500	1	COPERCHIO POST.	COUVERCLE	DECKEL	COVER			
18	66015700	1	ANELLO TENUTA	JOINT D'ETANCHEITE	DICHTUNGSRING	JUNT RING			
19	68011700	3	SPESSORE	EPAISSEUR	DICKE	THICKNESS	45x62x2		
20	60015100	4	VITE	VIS	SCHRAUBE	SCREW	TE 8x16 UNI 5739		
21	40180000	1	CHIUSURA	FERMATURE	VERSCHLUSS	LOCK			

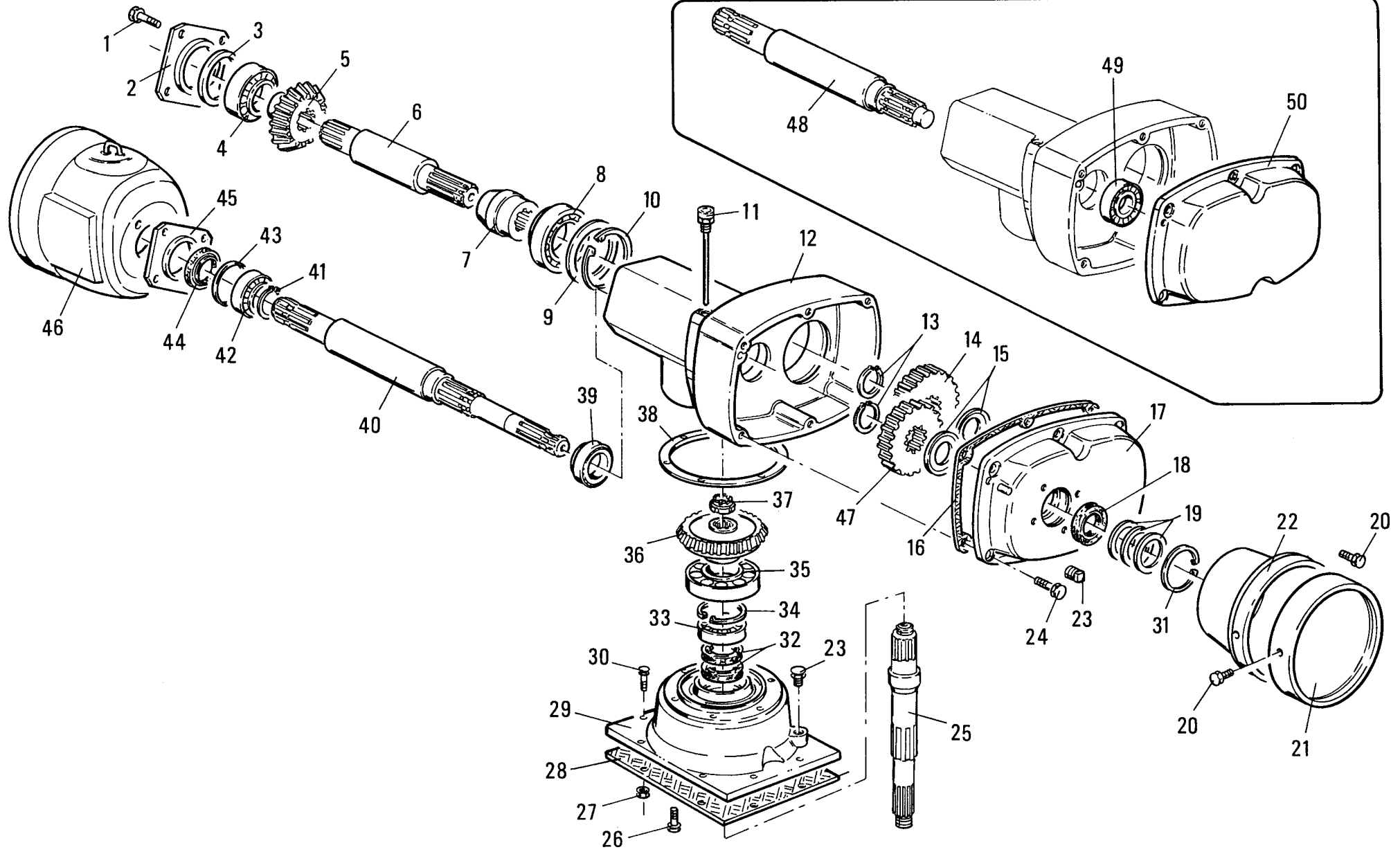

# MURATORI ME8C

TAV. 4.0

POS.	N° CODICE	Q	DESCRIZIONE	DESIGNATION	BENENNUNG	DESCRIPTION	DESIGNAZIONE	Da matr. De nr. serie Vom Seriennr. From serial nr.	Fino matr. Jusqu'au nr. serie Bis Seriennr. Up to serial nr.
------	-----------	---	-------------	-------------	-----------	-------------	--------------	--	---

I codici con asterisco sono stati utilizzati solo sulle seguenti matricole oltre a quello riportato in tabella:

60583 - 56396 - 56397 - 56398 - 56399

Les codes avec étoile ont été utilisés seulement sur les numéros de série suivantes:

Koden mit Sternchen wurden nur auf folgenden Seriennummer benutzt:

Codes with (\*) have been utilized only on following serial numbers:

22	68074300	1	PROTEZIONE	PROTECTION	SCHUTZ	GUARD			
23	68078800	2	TAPPO	BOUCHON	STOPFEN	PLUG	M16x1,5		
24	60021300	6	VITE	VIS	SCHRAUBE	SCREW	TE 10x30 UNI 5739		
25	31071800	1	ALBERO	ARBRE	WELLE	SHAFT			
26	60021200	8	VITE	VIS	SCHRAUBE	SCREW	TE 12x35 UNI 5739		
27	62010300	4	DADO	ECROU	MUTTER	NUT	M10x1,25 AUTOBLOCC.		
28	80014800	1	GUARNIZIONE	GARNITURE	DICHTUNG	SEAL			
29	01016500	1	SUPPORTO	SUPPORT	TRAEGER	SUPPORT			
30	60033700	8	VITE	VIS	SCHRAUBE	SCREW	TE 10x1,25x35 UNI 5740		
31	63001700	1	ANELLO ELASTICO	ARRETOIR	SPANNRING	SNAP-RING	Ø 62 I UNI 7437		
32	66015800	2	ANELLO TENUTA	JOINT D'ETANCHEITE	DICHTUNGSRING	JUNT RING			
33	67009400	1	CUSCINETTO	ROULEMENT	LAGER	BEARING	30210		
34	63000100	1	ANELLO ELASTICO	ARRETOIR	SPANNRING	SNAP-RING	Ø 90 I UNI 7437		
35	67001600	1	CUSCINETTO	ROULEMENT	LAGER	BEARING	30214		
36	10038700	1	CORONA CONICA	COURONNE CONIQUE	KEGELKRANZ	RING BEVEL	Z= 25		
37	62014200	1	GHIERA	FRETTE	NUTMUTTER	RING NUT	M40x1,5 CON COLLARE		
38	68079100		SPESSORE	EPAISSEUR	DICKE	THICKNESS			
39	67017700	1	CUSCINETTO	ROULEMENT	LAGER	BEARING	33109		
40	31072000	1	ALBERO	ARBRE	WELLE	SHAFT			
41	68033600	2	SPESSORE	EPAISSEUR	DICKE	THICKNESS	45x55x2		
42	67017700	1	CUSCINETTO	ROULEMENT	LAGER	BEARING	33109		

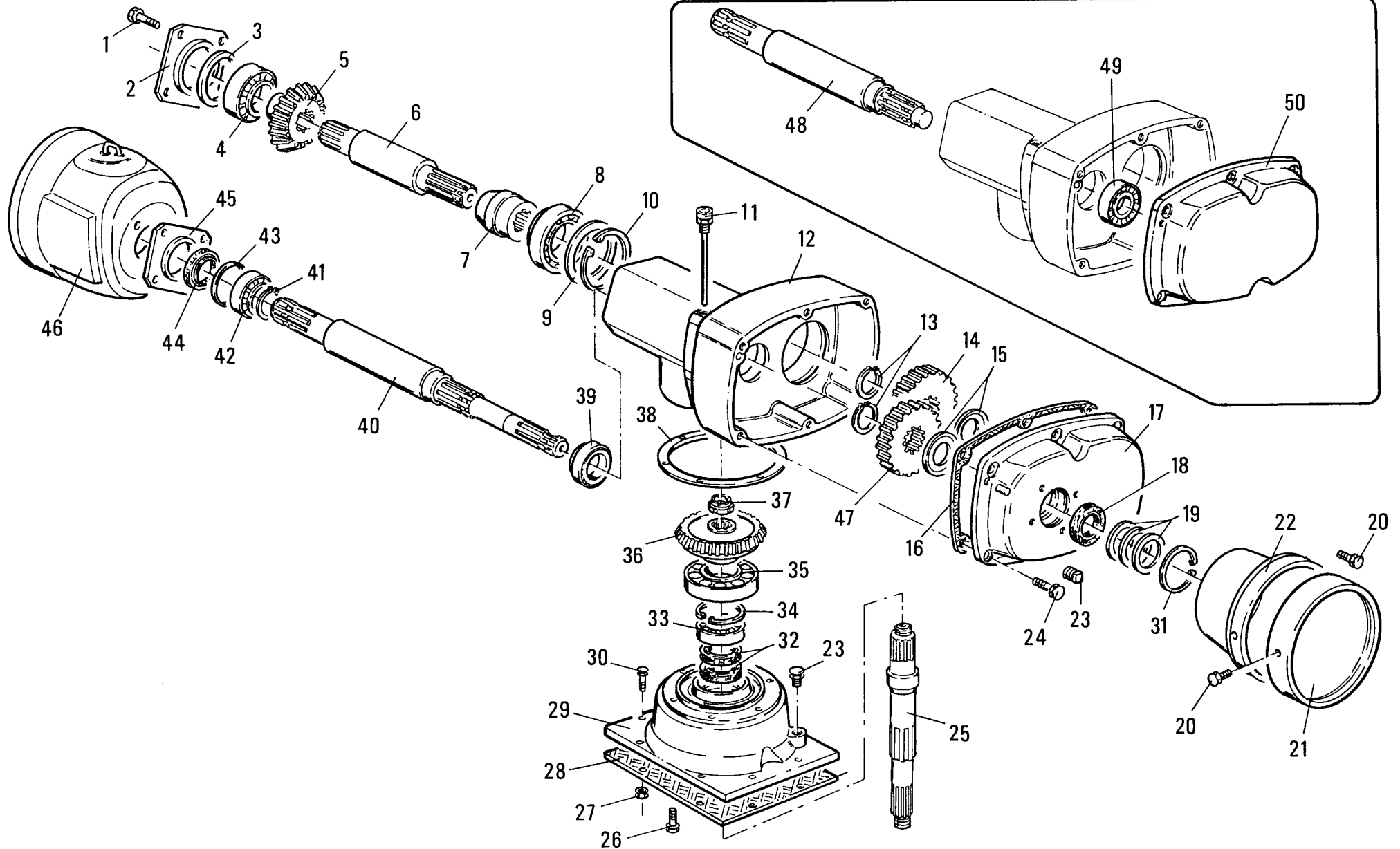





# MURATORI ME8 - ME8C

TAV. 5.0

POS.	N° CODICE	Q	DESCRIZIONE	DESIGNATION	BENENNUNG	DESCRIPTION	DESIGNAZIONE	Da matr.	Fino matr
								De nr. serie	Jusqu'au nr. serie
								Vom Seriennr.	Bis Seriennr.
								From serial nr.	Up to serial nr.
1	68065900	2	PERNO	PIVOT	BOLZEN	PIN			
2	30145900	2	BRACCIO	BRAS	ARM	ARM	150		
2	30145700	2	BRACCIO	BRAS	ARM	ARM	175-200-225-250		
3	60025900	2	VITE	VIS	SCHRAUBE	SCREW	TE 20 x 70 UNI 5737		
4									
5	62011400	2	DADO	ECROU	MUTTER	NUT	M 20 x 2,5 AUTOBLOCC.		
6	60006200	4	VITE	VIS	SCHRAUBE	SCREW	TE 14 x 55 UNI 5737		
7	60003400	8	VITE	VIS	SCHRAUBE	SCREW	TE 14 x 45 UNI 5737		
8	67009800	2	SUPPORTO	SUPPORT	TRAEGER	SUPPORT	UCF 207		
9	62010800	8	DADO	ECROU	MUTTER	NUT	M 14 x 2 AUTOBLOCC.		
10	30123600	2	STAFFA	BRIDE	BUEGEL	BRACKET			
11	62010800	4	DADO	ECROU	MUTTER	NUT	M 14 x 2 AUTOBLOCC.		
12	64001400	2	SPINA ELASTICA	GOUPILLE ELASTIQUE	SPANNSTIFT	ELASTIC PIN	8 x 50 UNI 6873		
13	42057700	1	RULLO GABBIA	ROULEAU CAGE	STABWALZE	CAGE ROLLER	150		
13	42057800	1	RULLO GABBIA	ROULEAU CAGE	STABWALZE	CAGE ROLLER	175		
13	42057900	1	RULLO GABBIA	ROULEAU CAGE	STABWALZE	CAGE ROLLER	200		
13	42058000	1	RULLO GABBIA	ROULEAU CAGE	STABWALZE	CAGE ROLLER	225		
13	42058100	1	RULLO GABBIA	ROULEAU CAGE	STABWALZE	CAGE ROLLER	250		
14	30145700	2	BRACCIO	BRAS	ARM	ARM	150-225		
14	30145800	2	BRACCIO	BRAS	ARM	ARM	175-200		
14	30145900	2	BRACCIO	BRAS	ARM	ARM	250		
15	40172800	1	TELAIO	CHASSIS	RAHMEN	FRAME	150		
15	40173200	1	TELAIO	CHASSIS	RAHMEN	FRAME	175		
15	40173300	1	TELAIO	CHASSIS	RAHMEN	FRAME	200		
15	40173400	1	TELAIO	CHASSIS	RAHMEN	FRAME	225		
15	40173500	1	TELAIO	CHASSIS	RAHMEN	FRAME	250		

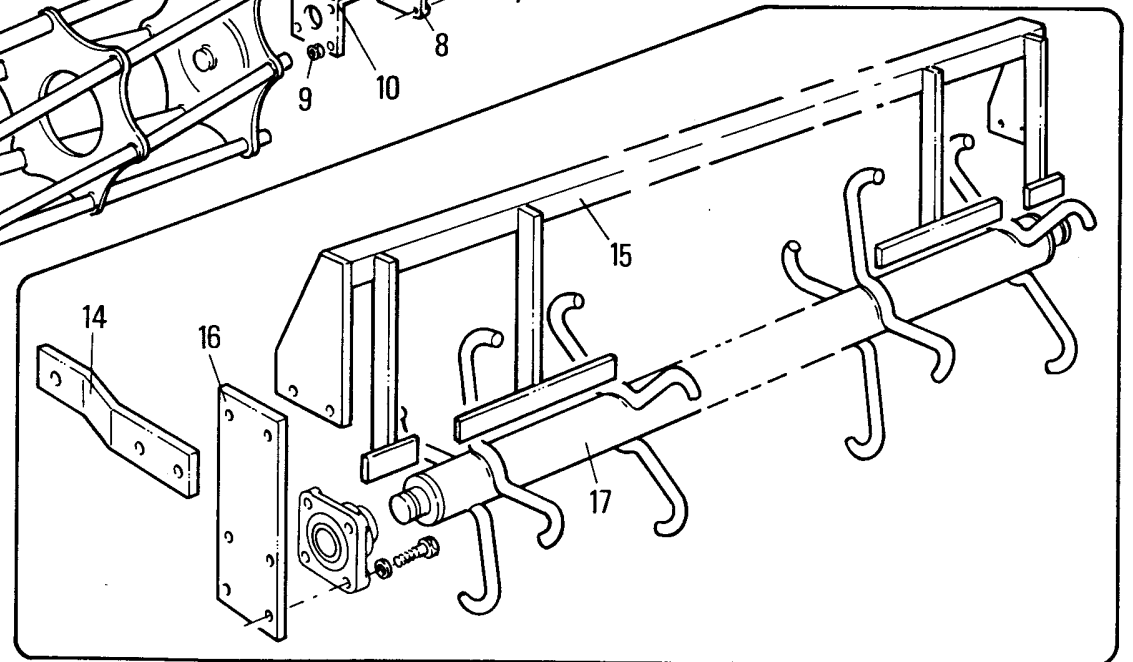
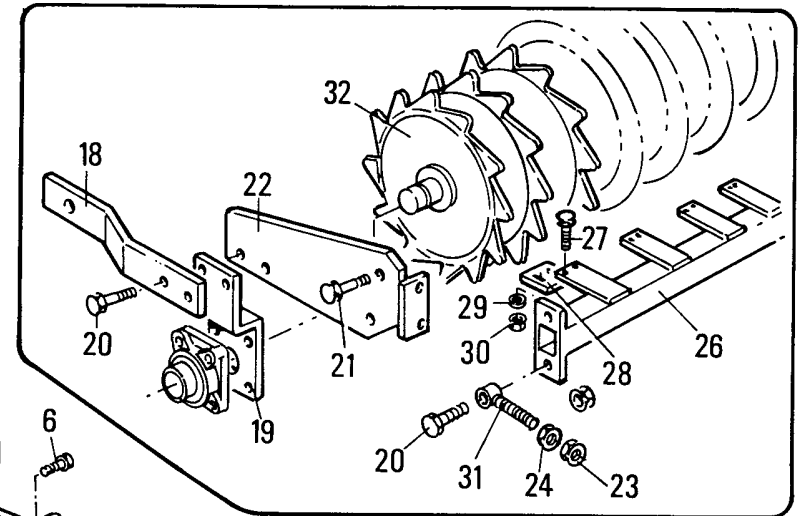
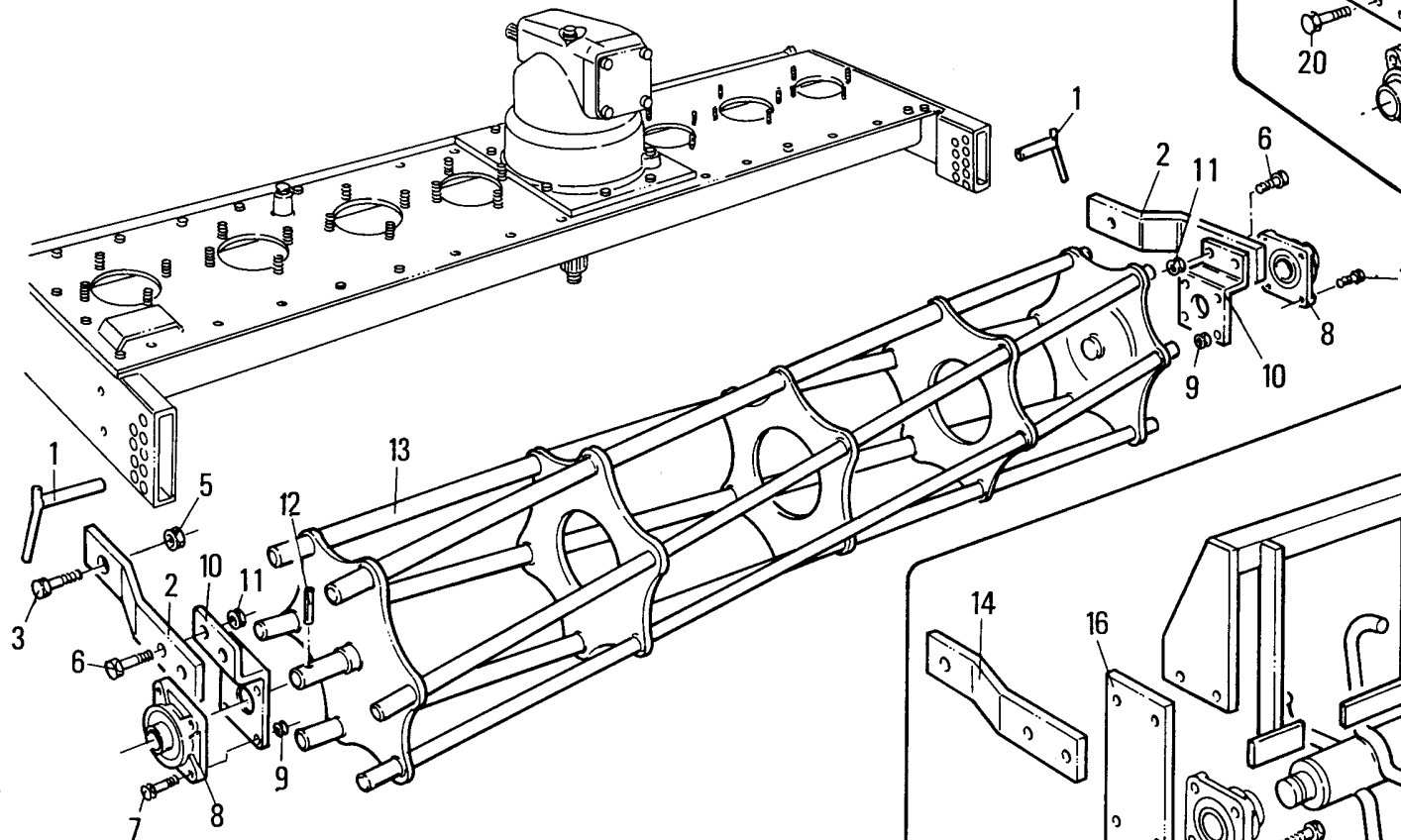

## MURATORI ME8 - ME8C

TAV. 5.0

POS.	N° CODICE	Q	DESCRIZIONE	DESIGNATION	BENENNUNG	DESCRIPTION	DESIGNAZIONE	Da matr.	Fino matr.
								De nr. serie Vom Seriennr. From serial nr.	Jusqu'au nr. serie Bis Seriennr. Up to serial nr.
16	30136600	2	STAFFA	BRIDE	BUEGEL	BRACKET			
17	42056900	1	RULLO PUNTONI	ROULEAU A POINTES	SPITZENWALZE	SPIKED ROLLER	150		
17	42057100	1	RULLO PUNTONI	ROULEAU A POINTES	SPITZENWALZE	SPIKED ROLLER	175		
17	42057200	1	RULLO PUNTONI	ROULEAU A POINTES	SPITZENWALZE	SPIKED ROLLER	200		
17	42057300	1	RULLO PUNTONI	ROULEAU A POINTES	SPITZENWALZE	SPIKED ROLLER	225		
17	42057400	1	RULLO PUNTONI	ROULEAU A POINTES	SPITZENWALZE	SPIKED ROLLER	250		
18	30145700	2	BRACCIO	BRAS	ARM	ARM	200-250		
19	30123600	2	STAFFA	BRIDE	BUEGEL	BRACKET			
20	60018000	2	VITE	VIS	SCHRAUBE	SCREW	TE 16x1,5x45 UNI 5738		
21	60024100	2	VITE	VIS	SCHRAUBE	SCREW	TE 16x1,5x55 UNI 5738		
22	40187100	1	BRACCIO SX	BRAS (G)	ARM (LINKS)	ARM (LH)			
22	40187200	1	BRACCIO DX	BRAS (D)	ARM (RECHTS)	ARM (RH)			
23	62003300	2	DADO	ECROU	MUTTER	NUT	M 16 x 1,5 UNI 5588		
24	62001500	2	DADO	ECROU	MUTTER	NUT	M 16 x 1,5 UNI 5589		
25	62003300	4	DADO	ECROU	MUTTER	NUT	M 16 x 1,5 UNI 5588		
26	45076100	1	RASTRELLIERA PACKER	RATELIER DU ROULEAU	ABSTREIFERGESTELL	ROLLER CLEANER RACK	200		
26	45076300	1	RASTRELLIERA PACKER	RATELIER DU ROULEAU	ABSTREIFERGESTELL	ROLLER CLEANER RACK	250		
27	60004600		VITE	VIS	SCHRAUBE	SCREW	TE 8x1,25x25 UNI 5739		
28	30145600		RASCHIETTO	GRATTOIR	ABSTREIFER	CLEANER			
29	61002900		RONDELLA	RONDELLE	SCHEIBE	WASHER	PIANA Ø 8 UNI 6592		
30	62002900		DADO	ECROU	MUTTER	NUT	M 8 x 1,25 UNI 5588		
31	40187300	2	VITE	VIS	SCHRAUBE	SCREW			
32	42058700	1	RULLO PACKER	ROULEAU PACKER	PACKERWALZE	PACKER ROLLER	200		
32	42058900	1	RULLO PACKER	ROULEAU PACKER	PACKERWALZE	PACKER ROLLER	250		





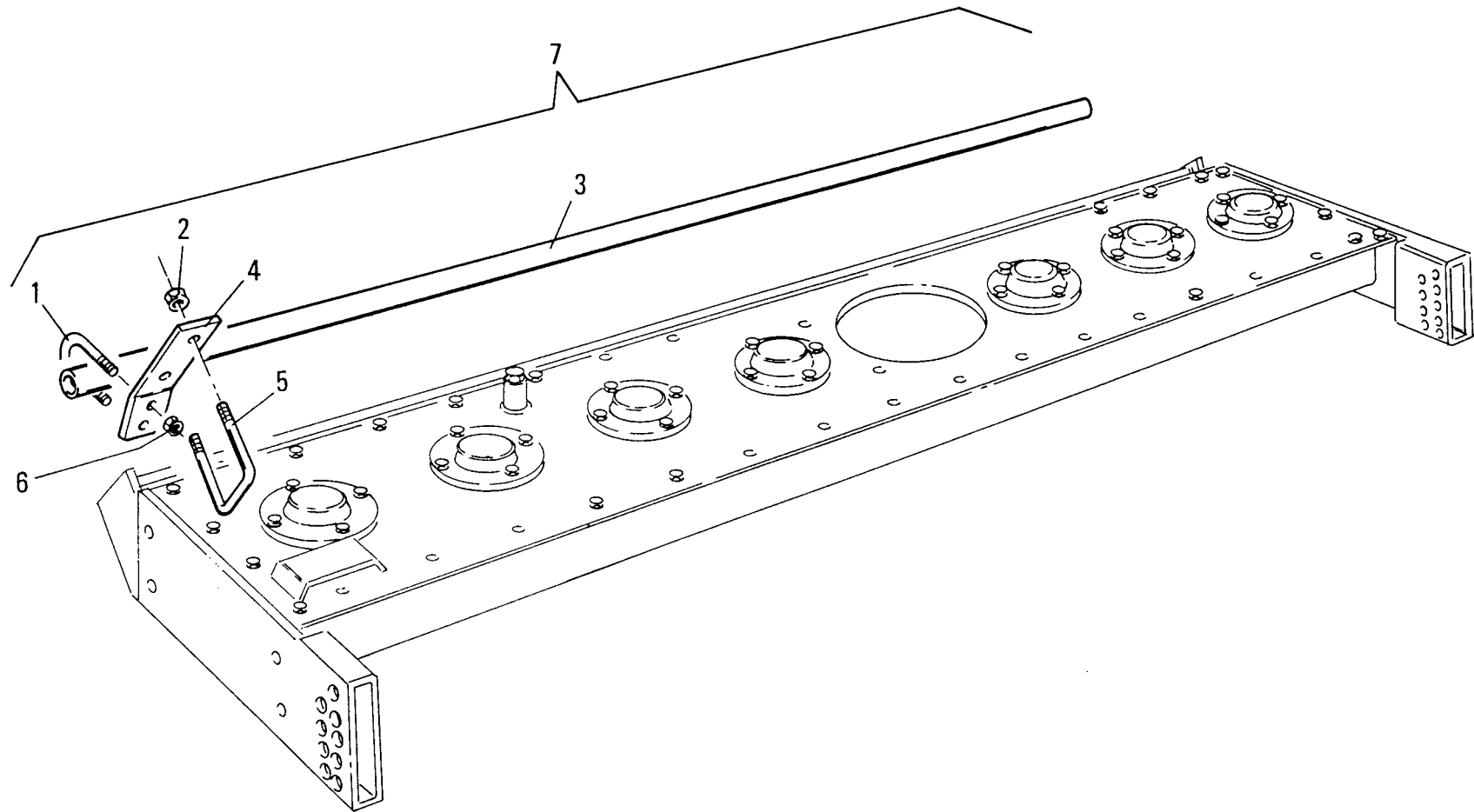



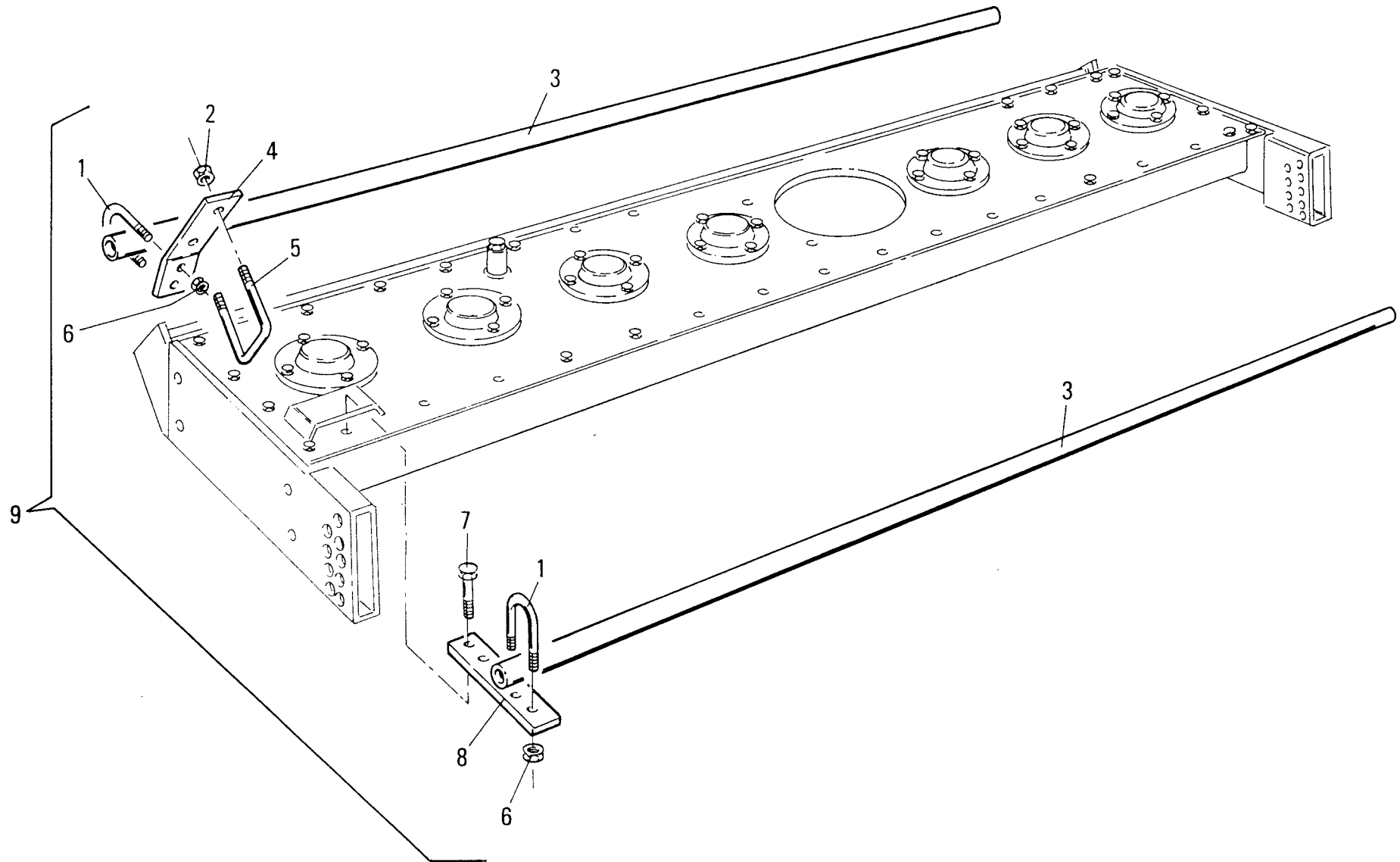



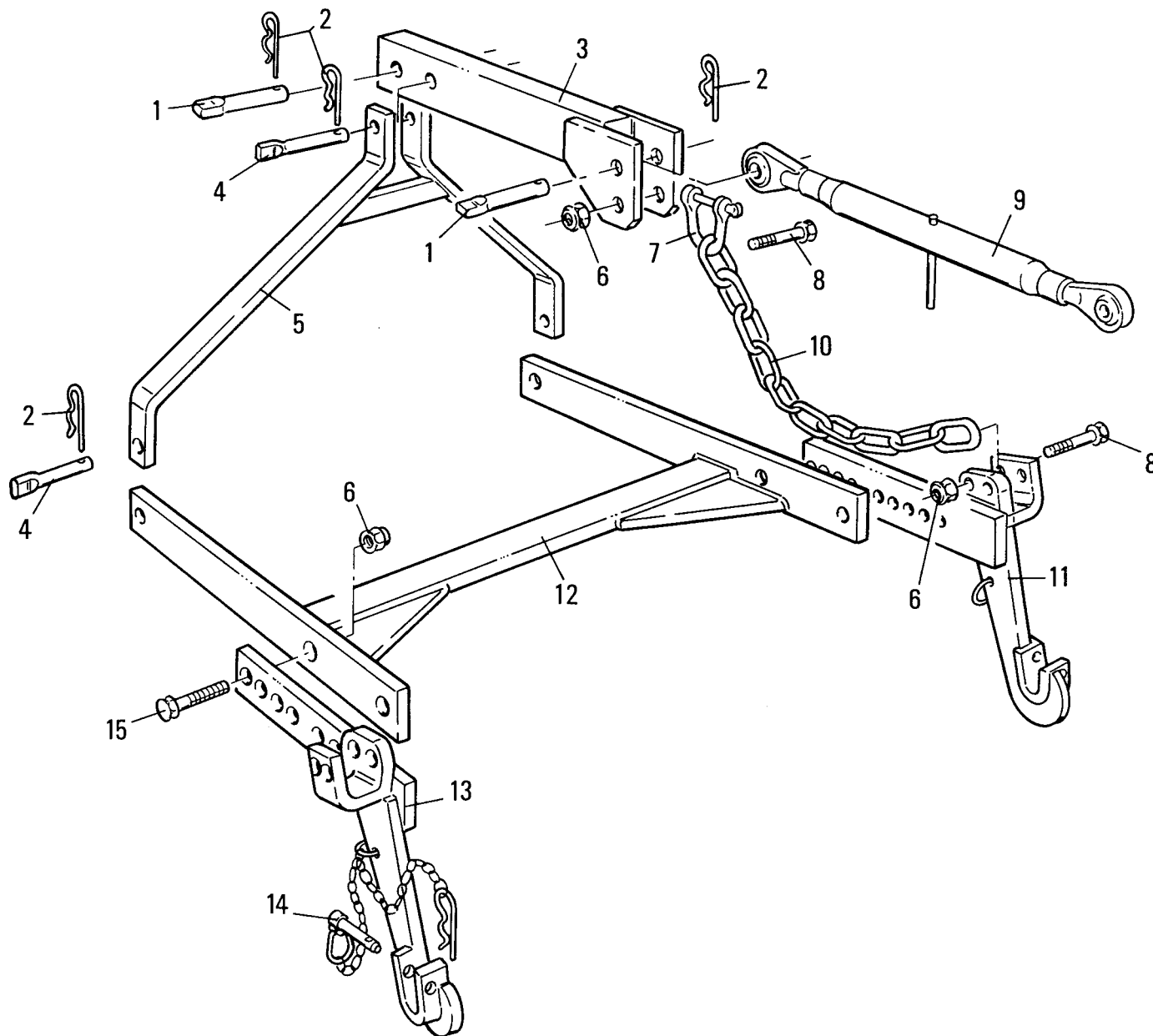





# MURATORI ME8 - ME8C (250)

TAV. 10.0

POS.	N° CODICE	Q	DESCRIZIONE	DESIGNATION	BENENNUNG	DESCRIPTION	DESIGNAZIONE	Da matr.	Fino matr
								De nr. serie Vom Seriennr. From serial nr.	Jusqu'au nr. serie Bis Seriennr. Up to serial nr.
1	68043500	1	ATTACCO RAPIDO	ATTELAGE RAPIDE	SCHNELLKUPPLUNG	QUICKLINKAGE			
2	61005700	1	RONDELLA	RONDELLE	SCHEIBE	WASHER	RAME 1/2"		
3	68077700	1	TUBO	TUBE	ROHR	TUBE			
4	68077300	1	CILINDRO	CYLINDRE	ZYLINDER	CYLINDER			
5	68077600	1	RUBINETTO	ROBINET	HAHN	TAP			
6	61005600	2	RONDELLA	RONDELLE	SCHEIBE	WASHER	RAME 3/8"		
7	68077500	1	NIPPLO	RACCORD	NIPPEL	NIPPLE	3/8"		
8	64001000	5	COPIGLIA	COUPILLE	SPLINT	COTTER PIN	AR Ø 5		
9	61003900	2	RONDELLA	RONDELLE	SCHEIBE	WASHER	PIANA 50 x 27 UNI 6592		
10	38022500	3	PERNO	PIVOT	BOLZEN	PIN	L= 115		
11	40205900	1	AGGANCIO	CROCHET	HAKEN	HOOK			
12	40205800	1	VITE	VIS	SCHRAUBE	SCREW			
13	30157800	2	TRAVE						
14	60033700	2	VITE	VIS	SCHRAUBE	SCREW	TE 24 x 180 UNI 5737		
15	40205500	1	TELAIO	CHASSIS	RAHMEN	FRAME			
16	38022400	2	PERNO	PIVOT	BOLZEN	PIN	L= 85		
17	30157700	2	TIRANTE	TIRANT	STANGE	TIEROD			
18	40205600	1	TELAIO	CHASSIS	RAHMEN	FRAME			
19	60035000	2	VITE	VIS	SCHRAUBE	SCREW	TE 18 x 50 UNI 5739		
20	60034900	2	VITE	VIS	SCHRAUBE	SCREW	TE 18 x 120 UNI 5737		
21	32155200	6	BOCCOLA	DOUILLE	BUECHSE	BUSHING			
22	40205300	1	STAFFA DX	BRIDE (D)	BUEGEL(RECHTS)	BRACKET (RH)			
23	62011200	4	DADO	ECROU	MUTTER	NUT	M 18 x 2,5 AUTOBLOCC.		
24	40205700	1	TELAIO	CHASSIS	RAHMEN	FRAME			
25	68077400	2	PERNO	PIVOT	BOLZEN	PIN			
26	40205400	1	STAFFA SX	BRIDE (G)	BUEGEL (LINKS)	BRACKET (LH)			

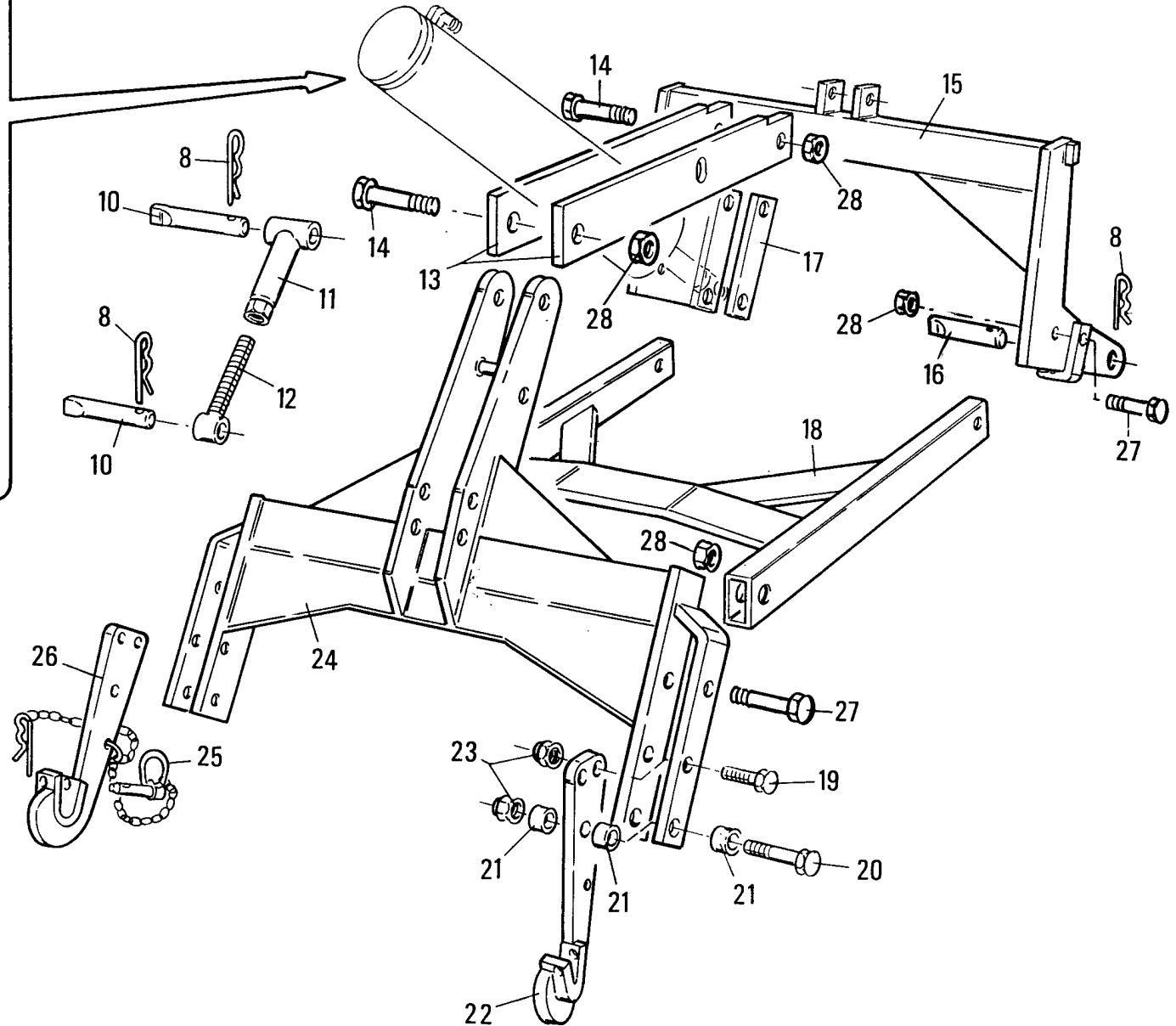
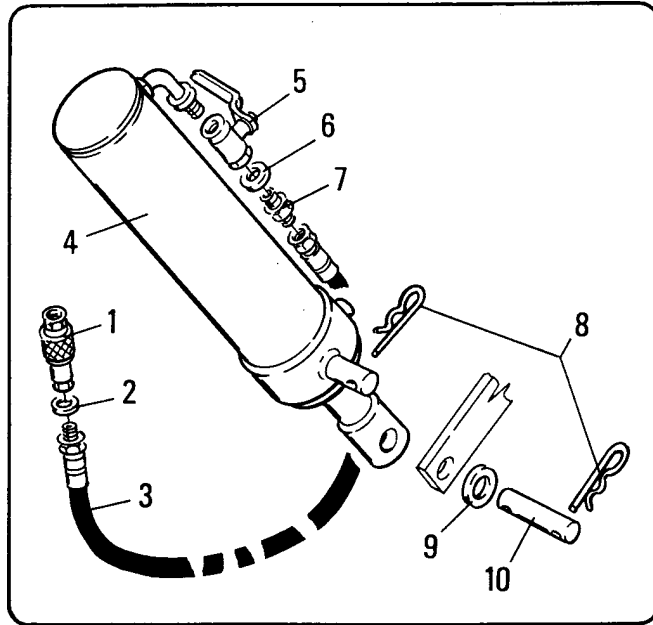







ZAPPATRICI - ERPICI ROTANTI - TRINCIATRICI

**MURATORIM** 

41051 CASTELNUOVO RANGONE (MODENA) Italy  
Via Pavarello, 21 - 21/A-B-C -P.O.Box 45 -  
Tel. ++39 059 535919 - Telefax ++39 059 537259  
<http://www.muratoriequip.it>  
e-mail: [info@muratoriequip.it](mailto:info@muratoriequip.it)