



MURATORI

**TIPO-TYPE-TYP
MM**

CATALOGO RICAMBI
Catalogue Pièces Detachées
Ersatzteilkatalog
Spare Parts Catalogue
Catálogo Recambios

EDIZIONE 01/1994



**NORME PER LE ORDINAZIONI - COMMANDES/NORMES - BESTELLNORMEN - HOW TO ORDER
INDICE DELLE TAVOLE - INDEX DES TABLES - TAFELVERZEICHNIS - TABLES INDEX**

MM

Per ordinare parti di ricambio specificare:

- tipo e matricola della macchina (apposti sulla macchina o sui documenti di acquisto);
- numero del riferimento del pezzo nel disegno (Pos.), numero della tavola (Tav.) e numero di codice

N.B.: le indicazioni destro o sinistro vengono date guardando la macchina da dietro.

Pour les commandes de pièces de rechange veuillez spécifier:

- type et numéro de serie de la machine (indiqués sur la machine et sur le bon d'achat);
- numéro de référence du pièce sur le plan (Pos.), numéro du plan (Tav.) et numero de code (codice)

N.B.: les indications droite ou gauche sont données en regardant la machine par derrière.

Zum Bestellen von Ersatzteilen folgendes angeben:

- Typ und Serien-Nr. der Maschine (zu finden auf der Maschine oder der Einkaufspapieren);
- Bezug-Nr. des Ersatzteils auf der Zeichnung (Pos.), Zeichnungsnummer (Tav.) und Kodenummer (codice)

N.B.: Die Angaben rechts und links verstehen sich so, dass man hinter der Maschine steht.

When ordering spare parts specify:

- machine type and serial number (found on the machine or on the purchasing documents);
- reference number of the part on the relative drawing (Pos.), number of the drawing (Tav.) and part number (codice)

N.B.: right-hand or left-hand indications are made by viewing the machine from the rear.

TAV. 1.0
GRUPPO TELAIO
ENSEMBLE CHASSIS
SATZ FÜR RAHMEN
KIT FOR FRAME

TAV. 2.0
GRUPPO RULLO ROTORE STANDARD A 4 ZAPPE
ENSEMBLE ROTOR STANDARD A 4 LAMES
SATZ FÜR STANDARDROTOR ZU 4 MESSER
KIT FOR STANDARD ROTOR 4 BLADES

TAV. 3.0
GRUPPO RIDUTTORE A 1 VELOCITA'
ENSEMBLE BOITIER MONOVITESS
SATZ FÜR EINGANGGETRIEBE
KIT FOR ONE-SPEED GEAR BOX

TAV. 4.0
GRUPPO RIDUTTORE A 1 VELOCITA'
(fino a matr. 32400)
ENSEMBLE BOITIER MONOVITESSE
(jusqu'au nr. de serie 32400)
SATZ FÜR EINGANGGETRIEBE
(bis Seriennr. 32400)
KIT FOR ONE-SPEED GEAR BOX
(up to serial nr. 32400)

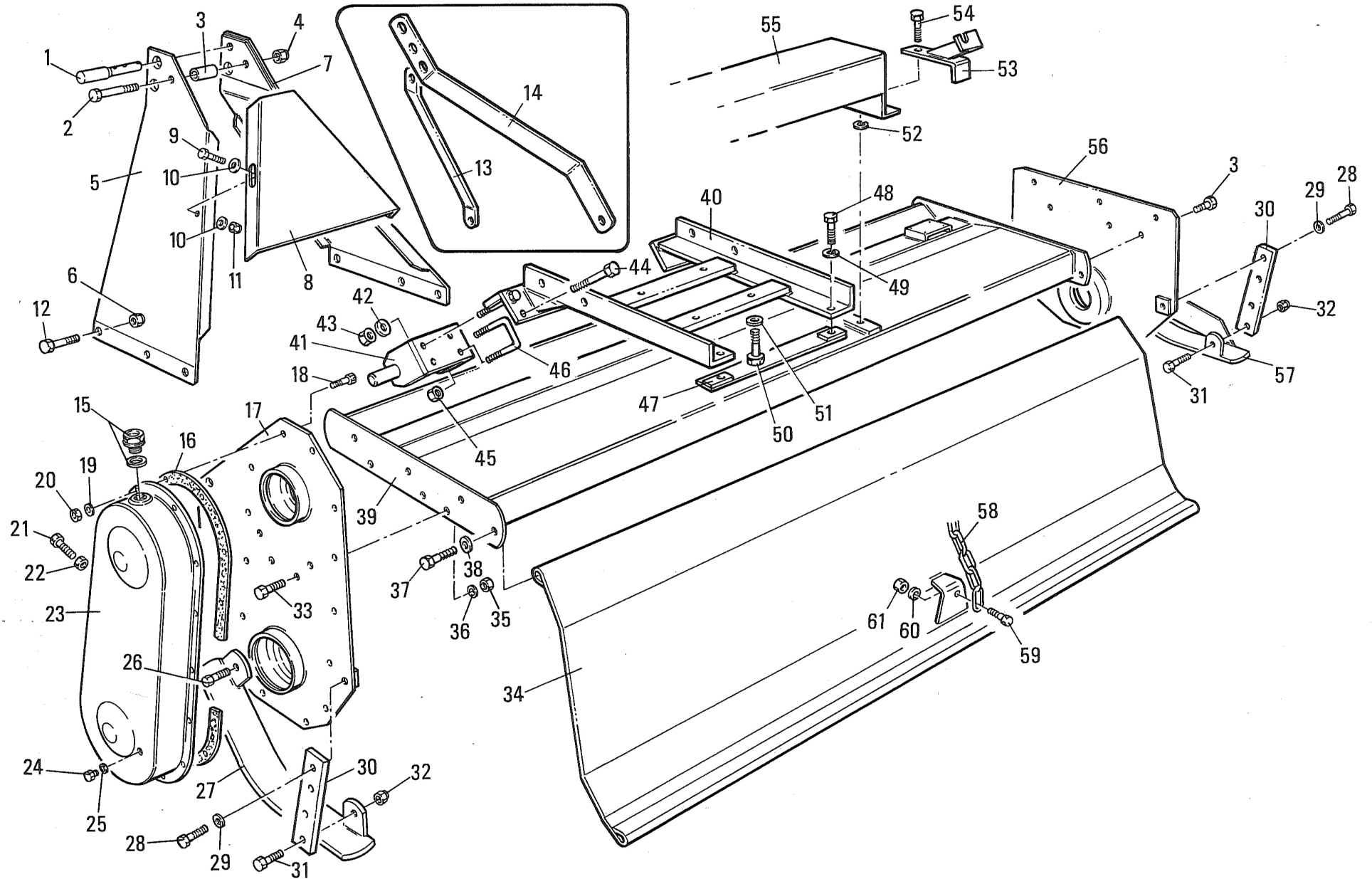

MURATORI MM

TAV. 1.0

POS.	N°	CODICE Q.	DESCRIZIONE	DESIGNATION	BENENNUNG	DESCRIPTION	DESIGNAZIONE	Da matr.	Fino matr.
								De nr. serie Vom Seriennr. From serial nr.	Jusqu'au nr. serie Bis Seriennr. Up to serial nr.
1	68062000	1	PERNO	AXE	BOLZEN	PIN			
2	60023100	1	VITE	VIS	SCHRAUBE	SCREW	TE 10x70 UNI 5737		
3	32004600	1	DISTANZIALE	ENTRETOISE	DISTANZSTUECK	SPACER			
4	62010400	1	DADO	ECROU	MUTTER	NUT	M 10x1,5 AUTOBLOCC.	24606	
5	40091900	1	ARCATA SX	ARCADE (G)	ARKADE (LINKS)	ARCADE (LH)		24606	
6	62010400	4	DADO	ECROU	MUTTER	NUT	M 10x1,5 AUTOBLOCC.	24606	
7	40092000	1	ARCATA DX	ARCADE (D)	ARKADE (RECHTS)	ARCADE (RH)		24606	
8	39098000	1	CHIUSURA	FERMATURE	VERSCHLUSS	LOCK		24606	
9	60015100	2	VITE	VIS	SCHRAUBE	SCREW	TE 8x16 UNI 5739 ZNT	24606	
10	61004700	4	RONDELLA	RONDELLE	SCHEIBE	WASHER	PIANA Ø 8 UNI 6592 ZNT	24606	
11	62007200	2	DADO	ECROU	MUTTER	NUT	M 8x1,25 UNI 5587 ZNT	24606	
12	60017900	4	VITE	VIS	SCHRAUBE	SCREW	TE 10x25 UNI 5739 ZNT	24606	
13	30031000	2	TIRANTE	TIRANT	STANGE	TIEROD		24605	
14	30031400	2	TIRANTE	TIRANT	STANGE	TIEROD		24605	
15	68000500	1	TAPPO	BOUCHON	STOPFEN	PLUG			
16	80006600	1	GUARNIZIONE	GARNITURE	DICHTUNG	SEAL			
17	40034601	1	PIASTRA	PLAQUE	PLATTE	PLATE			
18	60000900	10	VITE	VIS	SCHRAUBE	SCREW	TE 8x20 UNI 5739		
19	61000600	10	RONDELLA	RONDELLE	SCHEIBE	WASHER	DENT. INT. Ø 8 UNI 3704		
20	62000700	10	DADO	ECROU	MUTTER	NUT	M 8x1,25 UNI 5587		
21	60030200	1	VITE	VIS	SCHRAUBE	SCREW	TE 10x80 UNI 5739		
22	62000500	1	DADO	ECROU	MUTTER	NUT	M 10x1,5 UNI 5587		
23	40033000	1	COPERCHIO	COUVERCLE	DECKEL	COVER			
24	60001100	1	VITE	VIS	SCHRAUBE	SCREW	TE 10x10 UNI 5739 4.8		
25	61000800	1	RONDELLA	RONDELLE	SCHEIBE	WASHER	PIANA Ø10 ALLUMINIO		
26	60002300	2	VITE	VIS	SCHRAUBE	SCREW	TE 10x25 UNI 5739		

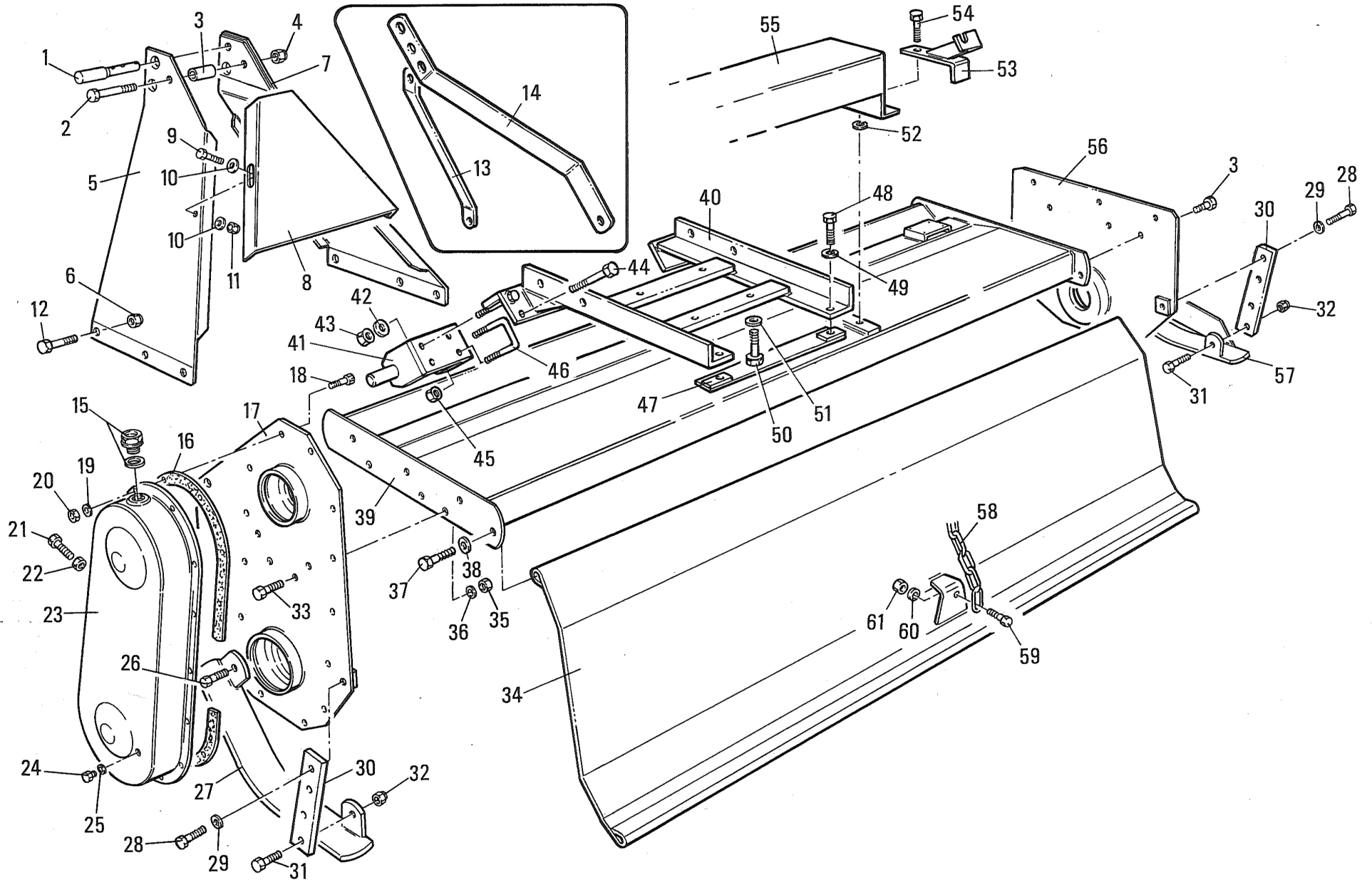

MURATORI MM

TAV. 1.0

POS.	N°	CODICE Q.	DESCRIZIONE	DESIGNATION	BENENNUNG	DESCRIPTION	DESIGNAZIONE	Da matr.	Fino matr.
								De nr. serie Vom Seriennr. From serial nr.	Jusqu'au nr. serie Bis Seriennr. Up to serial nr.
27	40033300	1	SLITTA SX	PATIN (G)	STUTZTKUFE (LINKS)	SKID (LH)			
28	60004000	2	VITE	VIS	SCHRAUBE	SCREW	TE 10x20 UNI 5739		
29	61000400	2	RONDELLA	RONDELLE	SCHEIBE	WASHER	DENT. INT. Ø10 UNI 3704		
30	30030800	2	ASTA REGOLAZIONE	TIGE REGOLATION	TIEFEINSTELLUNGSSTANG	DEPHT CONTROL ROD			
31	60002300	2	VITE	VIS	SCHRAUBE	SCREW	TE 10x25 UNI 5739		
32	62000500	2	DADO	ECROU	MUTTER	NUT	M 10x1,5 UNI 5587		
33	60002300	12	VITE	VIS	SCHRAUBE	SCREW	TE 10x25 UNI 5739		
34	41052400	1	COFANO	CAPOT	SCHUTZHAUBE	HOOD	MM 085		
34	41052600	1	COFANO	CAPOT	SCHUTZHAUBE	HOOD	MM 105		
34	41052700	1	COFANO	CAPOT	SCHUTZHAUBE	HOOD	MM 115		
34	41052800	1	COFANO	CAPOT	SCHUTZHAUBE	HOOD	MM 125		
35	62000500	12	DADO	ECROU	MUTTER	NUT	M 10x1,5 UNI 5587		
36	61000400	12	RONDELLA	RONDELLE	SCHEIBE	WASHER	DENT. INT. Ø10 UNI 3704		
37	60010700	2	VITE	VIS	SCHRAUBE	SCREW	TE 10x45 UNI 5739		
38	61001500	2	RONDELLA	RONDELLE	SCHEIBE	WASHER	GROWER Ø10 UNI 1751		
39	41051300	1	TELAIO	CHASSIS	RAHMEN	FRAME	MM 085	32400	
39	41051500	1	TELAIO	CHASSIS	RAHMEN	FRAME	MM 105	32400	
39	41051700	1	TELAIO	CHASSIS	RAHMEN	FRAME	MM 125	32400	
39	41083000	1	TELAIO	CHASSIS	RAHMEN	FRAME	MM 085	32401	
39	41083200	1	TELAIO	CHASSIS	RAHMEN	FRAME	MM 105	32401	
39	41083300	1	TELAIO	CHASSIS	RAHMEN	FRAME	MM 115	32401	
39	41083400	1	TELAIO	CHASSIS	RAHMEN	FRAME	MM 125	32401	
40	40110200	1	CASTELLO SCORR.	SYSTEME DEPORTABLE	GLEITENSCHLOSS	SLIDING SYSTEM		32401	
40	40069801	1	MONTANTE DX	MONTANT (D)	SAEULE (RECHTS)	PILLAR (RH)		32400	
40	40069702	1	MONTANTE SX	MONTANT (G)	SAEULE (LINKS)	PILLAR (LH)		32400	
41	40069500	2	STAFFA	BRIDE	BUEGEL	BRACKET			

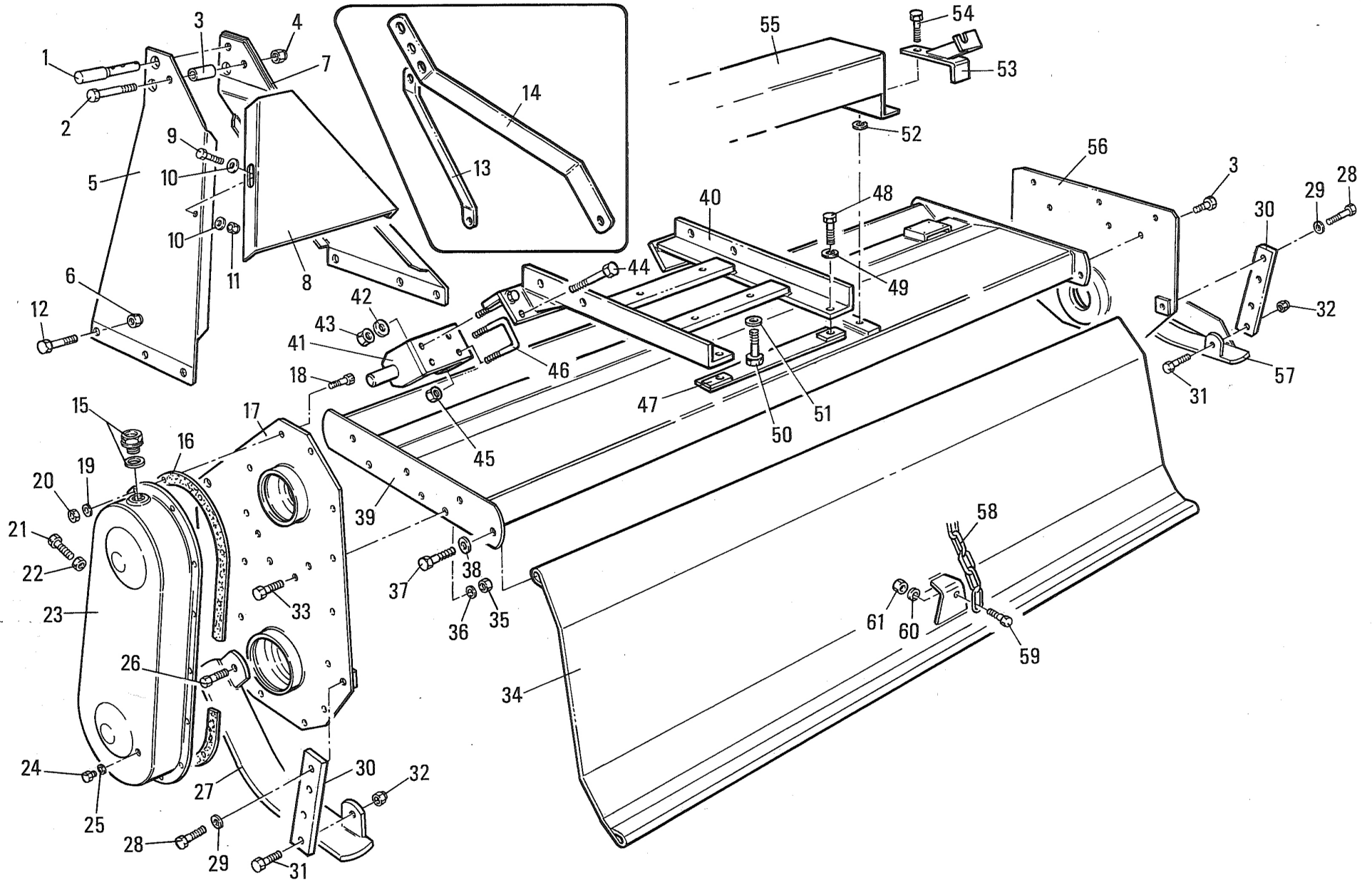

MURATORI MM

TAV. 1.0

POS.	N°	CODICE Q.	DESCRIZIONE	DESIGNATION	BENENNUNG	DESCRIPTION	DESIGNAZIONE	Da matr.	Fino matr.
								De nr. serie Vom Seriennr. From serial nr.	Jusqu'au nr. serie Bis Seriennr. Up to serial nr.
41	40069400	2	STAFFA	BRIDE	BUEGEL	BRACKET	CATEGORIA0		
42	61000400	4	RONDELLA	RONDELLE	SCHEIBE	WASHER	DENT. int Ø 10 UNI 3704		
43	62000500	4	DADO	ECROU	MUTTER	NUT	M 10x1,5 UNI 5587	32401	
44	60006800	2	VITE	VIS	SCHRAUBE	SCREW	TE 10x70 UNI 5737	32401	
45	62010200	4	DADO	ECROU	MUTTER	NUT	M 8 AUTOBLOCC.	46984	
46	38018900	2	CAVALLOTTO	ARRETOIR	KLEMMSTUECK	UBOLT	M 8	46984	
47	40069600	1	PIATTO	PLAQUE	PLATTE	DISC			
48	60002300	2	VITE	VIS	SCHRAUBE	SCREW	TE 10x25 UNI 5739		
49	61000400	2	RONDELLA	RONDELLE	SCHEIBE	WASHER	DENT. INT Ø 10 UNI 3704		
50	60020700	4	VITE	VIS	SCHRAUBE	SCREW	TE 10x120 UNI 5737 ZNT	32401	
51	61004900	4	RONDELLA	RONDELLE	SCHEIBE	WASHER	PIANA Ø10 UNI 6592 ZNT	32401	
52	61000400	2	RONDELLA	RONDELLE	SCHEIBE	WASHER	DENT. INT Ø 10 UNI 3704		
53	40069300	1	AGGANCI	CROCHET	HAKEN	HOOK			
54	60004000	2	VITE	VIS	SCHRAUBE	SCREW	TE 10x20 UNI 5739		
55	40070100	1	PROTEZIONE	PROTECTION	SCHUTZ	GUARD	MM 085		32400
55	40070200	1	PROTEZIONE	PROTECTION	SCHUTZ	GUARD	MM 105		32400
55	40070300	1	PROTEZIONE	PROTECTION	SCHUTZ	GUARD	MM 115-125		32400
55	40107700	1	PROTEZIONE	PROTECTION	SCHUTZ	GUARD	MM 085	32401	
55	40107800	1	PROTEZIONE	PROTECTION	SCHUTZ	GUARD	MM 105	32401	
55	40107900	1	PROTEZIONE	PROTECTION	SCHUTZ	GUARD	MM 115-125	32401	
56	40034501	1	FIANCO	FLANC	SEITENWAND	SIDE FRAME			
57	40033201	1	SLITTA DX	CHARIOT DX	STUTZTKUFE (RECHTS)	SKID (RH)			
58	68022800	1	CATENA	CHAINE	KETTE	CHAIN			
59	60020400	1	VITE	VIS	SCHRAUBE	SCREW	TE 12x25 UNI 5739 ZNT		
60	61005000	1	RONDELLA	RONDELLE	SCHEIBE	WASHER	PIANA Ø12 UNI 6592 ZNT		
61	62000600	1	DADO	ECROU	MUTTER	NUT	M 12x1,75 UNI 5587		

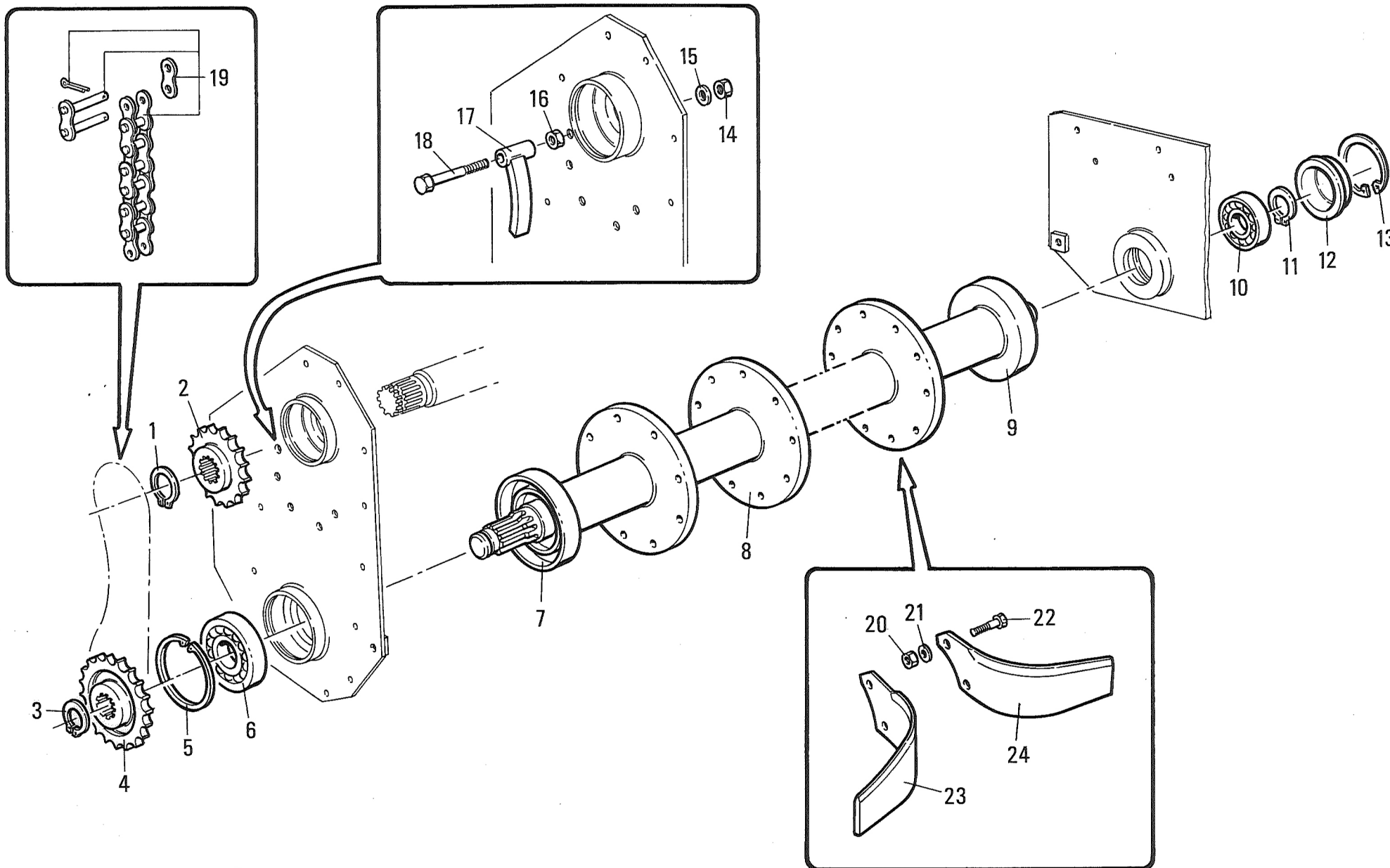

MURATORI MM

TAV. 2.0

POS.	N°	CODICE Q.	DESCRIZIONE	DESIGNATION	BENENNUNG	DESCRIPTION	DESIGNAZIONE	Da matr.	Fino matr.
								De nr. serie Vom Seriennr. From serial nr.	Jusqu'au nr. serie Bis Seriennr. Up to serial nr.
1	63003000	1	ANELLO ELASTICO	ARRETOIR	SPANNRING	SNAP-RING	Ø 29 E UNI 7435		
2	10014900	1	PIGNONE	PIGNON	RITZEL	PINION	Z 11 - 3/4"		
3	63002400	1	ANELLO ELASTICO	ARRETOIR	SPANNRING	SNAP-RING	Ø 34 E UNI 7435		
4	10014801	1	CORONA	COURONNE	KRANZ	CROWN	Z 19 - 3/4"		
5	63000300	1	ANELLO ELASTICO	ARRETOIR	SPANNRING	SNAP-RING	Ø 72 I UNI 7437		
6	67006700	1	CUSCINETTO	ROULEMENT	LAGER	BEARING	6207 2RS		
7	39083600	1	CAPPELOTTO SX	BOUCHON (G)	ABSCHULUSSKAPPE (L)	CAP NUT (LH)			
8	42009502	1	ROTORE	ROTOR	ROTOR	ROTOR	MM 085		
8	42009702	1	ROTORE	ROTOR	ROTOR	ROTOR	MM 105		
8	42009802	1	ROTORE	ROTOR	ROTOR	ROTOR	MM 115		
8	42009902	1	ROTORE	ROTOR	ROTOR	ROTOR	MM 125		
9	39083500	1	CAPPELOTTO DX	BOUCHON (D)	ABSCHULUSSKAPPE (R)	CAP NUT (RH)			
10	67006400	1	CUSCINETTO	ROULEMENT	LAGER	BEARING	6206 2RS		
11	63000400	1	ANELLO ELASTICO	ARRETOIR	SPANNRING	SNAP-RING	Ø 30 E UNI 7435		
12	39036500	1	COPERCHIO	COUVERCLE	DECKEL	COVER			
13	63005200	1	ANELLO ELASTICO	ARRETOIR	SPANNRING	SNAP-RING	Ø 62 I UNI 7437		
14	62001100	1	DADO	ECROU	MUTTER	NUT	M 12x1,75 UNI 5589		
15	61000500	1	RONDELLA	RONDELLE	SCHEIBE	WASHER	DENT. INT. Ø 12 UNI 3704		
16	62001100	1	DADO	ECROU	MUTTER	NUT	M 12x1,75 UNI 5589		
17	40033102	1	TENDICATENA	TENDEUR DE CHAINE	KETTENHALTERUNG	CHAINE TIGHTENER			
18	60011600	1	VITE	VIS	SCHRAUBE	SCREW	TE 12x50 UNI 5737		
19	68018100	1	CATENA COMPLETA	CHAINE	KETTE	CHAIN	ASA 60 3/4" 44 MG		
20	62000500		DADO	ECROU	MUTTER	NUT	M 10x1,5 UNI 5587		
21	61000400		RONDELLA	RONDELLE	SCHEIBE	WASHER	DENT. INT. Ø 10 UNI 3704		
22	60002300		VITE	VIS	SCHRAUBE	SCREW	TE 10x25 UNI 5739		
23	12005002		ZAPPA CURVA SX	LAME COURBE (G)	GEBOGENES MESSER (L)	CURVED BLADE (LH)			

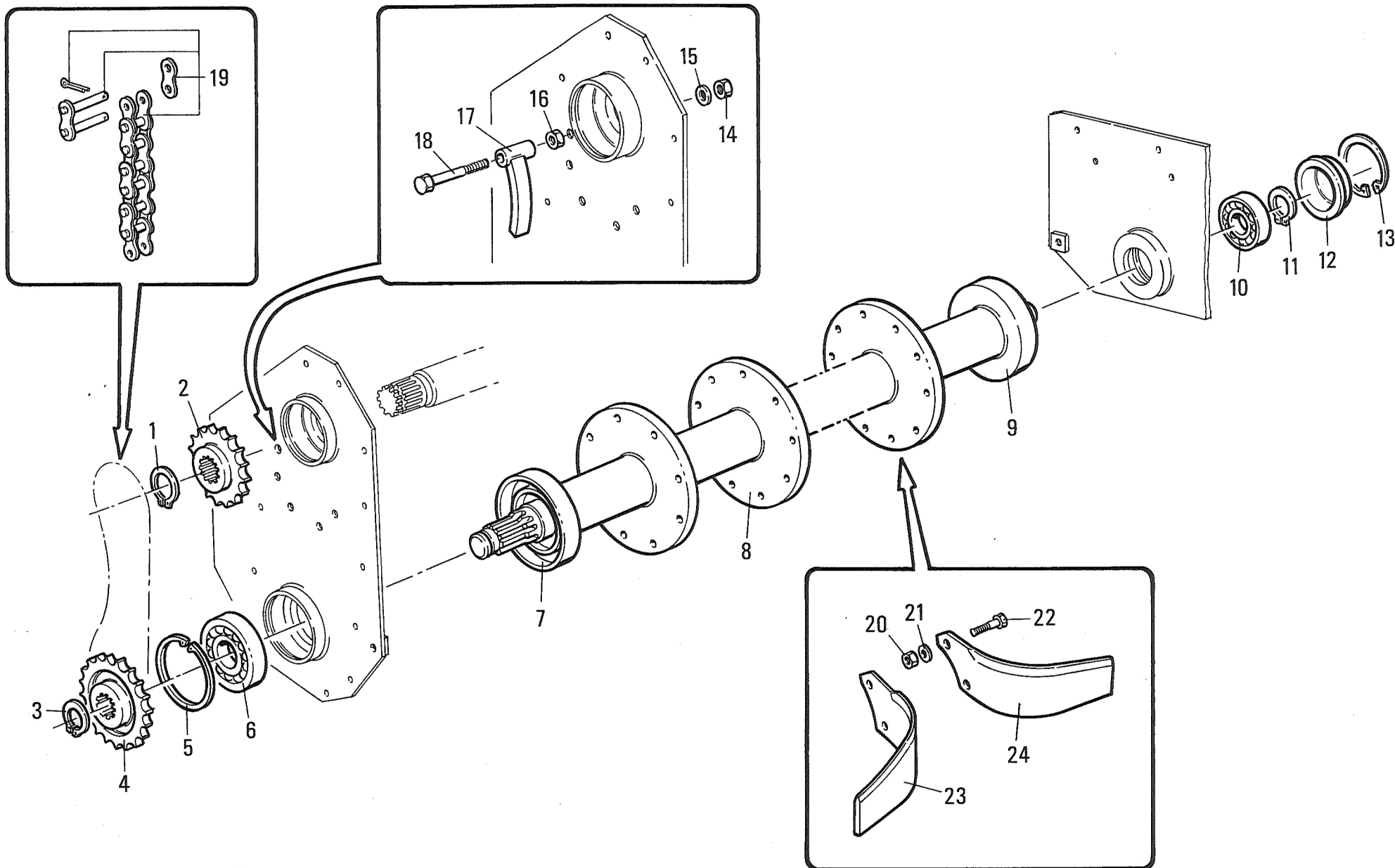

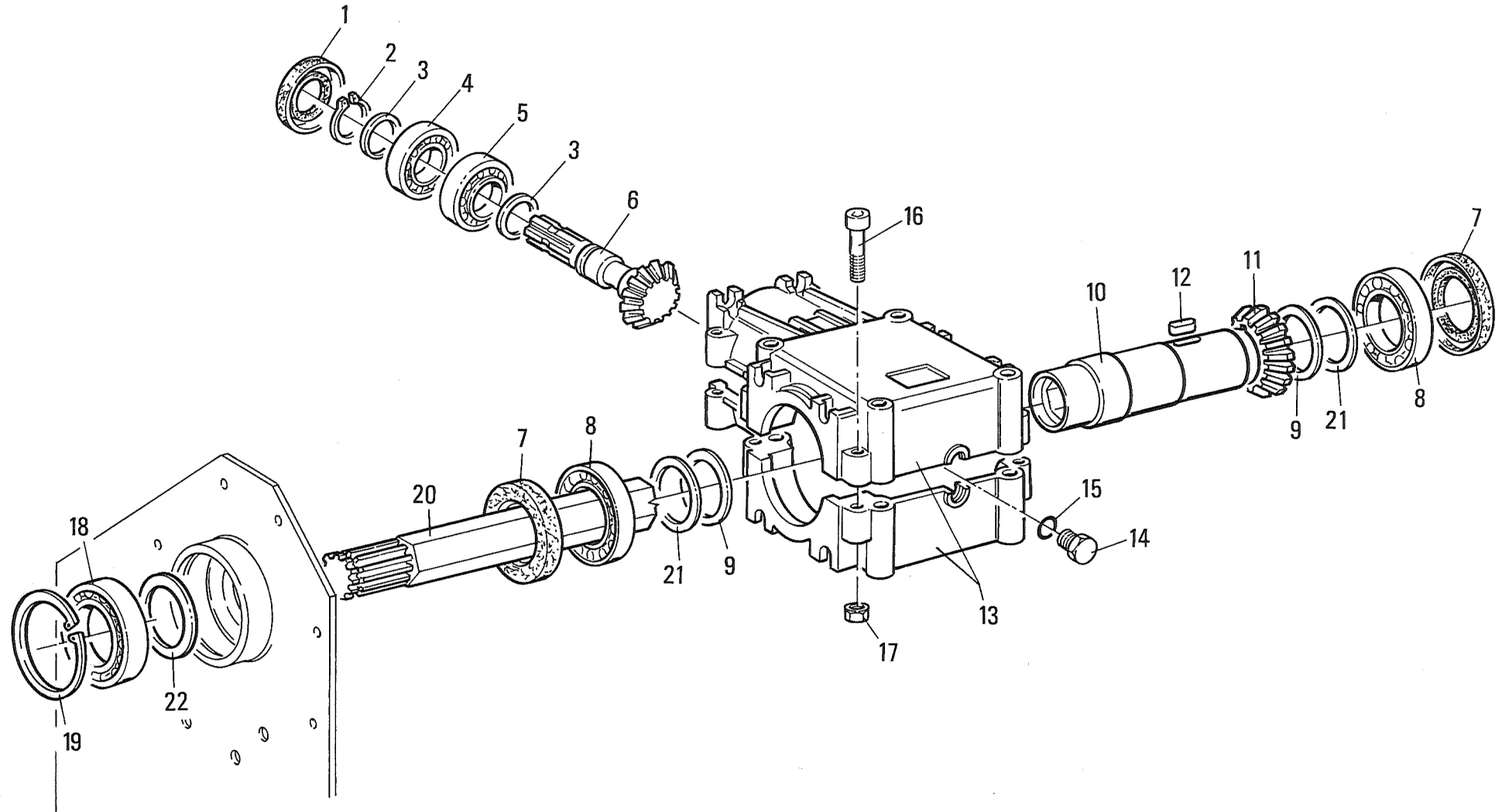

MURATORI MM

TAV. 3.0

POS.	N°	CODICE Q.	DESCRIZIONE	DESIGNATION	BENENNUNG	DESCRIPTION	DESIGNAZIONE	Da matr.	Fino matr.
								De nr. serie Vom Seriennr. From serial nr.	Jusqu'au nr. serie Bis Seriennr. Up to serial nr.
1	66011600	1	ANELLO TENUTA	JOINT D'ETANCHEITE	DICHTUNGSRING	JUNT RING	35 x 62 x 7	32401	
2	63000600	1	ANELLO ELASTICO	ARRETOIR	SPANNRING	SNAP-RING	Ø 35 E UNI 7435	32401	
3	68052300	2	SPESSORE	EPAISSEUR	DICKE	THICKNESS	45 x 35 x 06	32401	
4	67003700	1	CUSCINETTO	ROULEMENT	LAGER	BEARING	6207	32401	
5	67002100	1	CUSCINETTO	ROULEMENT	LAGER	BEARING	6307	32401	
6	10012700	1	ALBERO	ARBRE	WELLE	SHAFT	Z 13 M 5	32401	
6	10034500	1	ALBERO	ARBRE	WELLE	SHAFT	Z 10 2000 R.P.M	32401	
7	66008400	2	ANELLO TENUTA	JOINT D'ETANCHEITE	DICHTUNGSRING	JUNT RING	40 x 62 x 7	32401	
8	67004400	2	CUSCINETTO	ROULEMENT	LAGER	BEARING	6208	32401	
9	32123000	2	DISTANZIALE	ENTRETOISE	DISTANZSTUEECK	SPACER		32401	
10	32065100	1	CANOTTO	TUBE	ROHR	TUBE		32401	
11	10034600	1	CORONA	COURONNE	KRANZ	CROWN	Z 41 2000 R.P.M	32401	
11	10022400	1	CORONA	COURONNE	KRANZ	CROWN	Z 19 M 5	32401	
12	65001200	1	LINGUETTA	CLAVETTE	KEIL	KEY	8 x 7 x 25 UNI 6604	32401	
13	03001400	2	SEMISCATOLA	DEMI-CARTER	GEHAUESHAELFTE	HALF CASE		32401	
14	68051300	1	TAPPO	BOUCHON	STOPFEN	PLUG		32401	
15	66011100	1	ANELLO TENUTA	JOINT D'ETANCHEITE	DICHTUNGSRING	JUNT RING	OR 3062	32401	
16	60020500	8	VITE	VIS	SCHRAUBE	SCREW	TCEI 8x55 UNI 5931 8.8	32401	
17	62000700	8	DADO	ECROU	MUTTER	NUT	M 8x 1,25 UNI 5587	32401	
18	67006400	1	CUSCINETTO	ROULEMENT	LAGER	BEARING	6206 2RS	32401	
19	63005200	1	ANELLO ELASTICO	ARRETOIR	SPANNRING	SNAP-RING	Ø 62 I UNI 7437	32401	
20	38010800	1	SEMIASSE	DEMI-ESSIEU	ACHSWELLE	AXLE SHAFT	MM 085	32401	
20	38011000	1	SEMIASSE	DEMI-ESSIEU	ACHSWELLE	AXLE SHAFT	MM 105	32401	
20	38011100	1	SEMIASSE	DEMI-ESSIEU	ACHSWELLE	AXLE SHAFT	MM 115	32401	
20	38011200	1	SEMIASSE	DEMI-ESSIEU	ACHSWELLE	AXLE SHAFT	MM 125	32401	
21	68052200	2	SPESSORE	EPAISSEUR	DICKE	THICKNESS	70 x 50 x 0,5	32401	

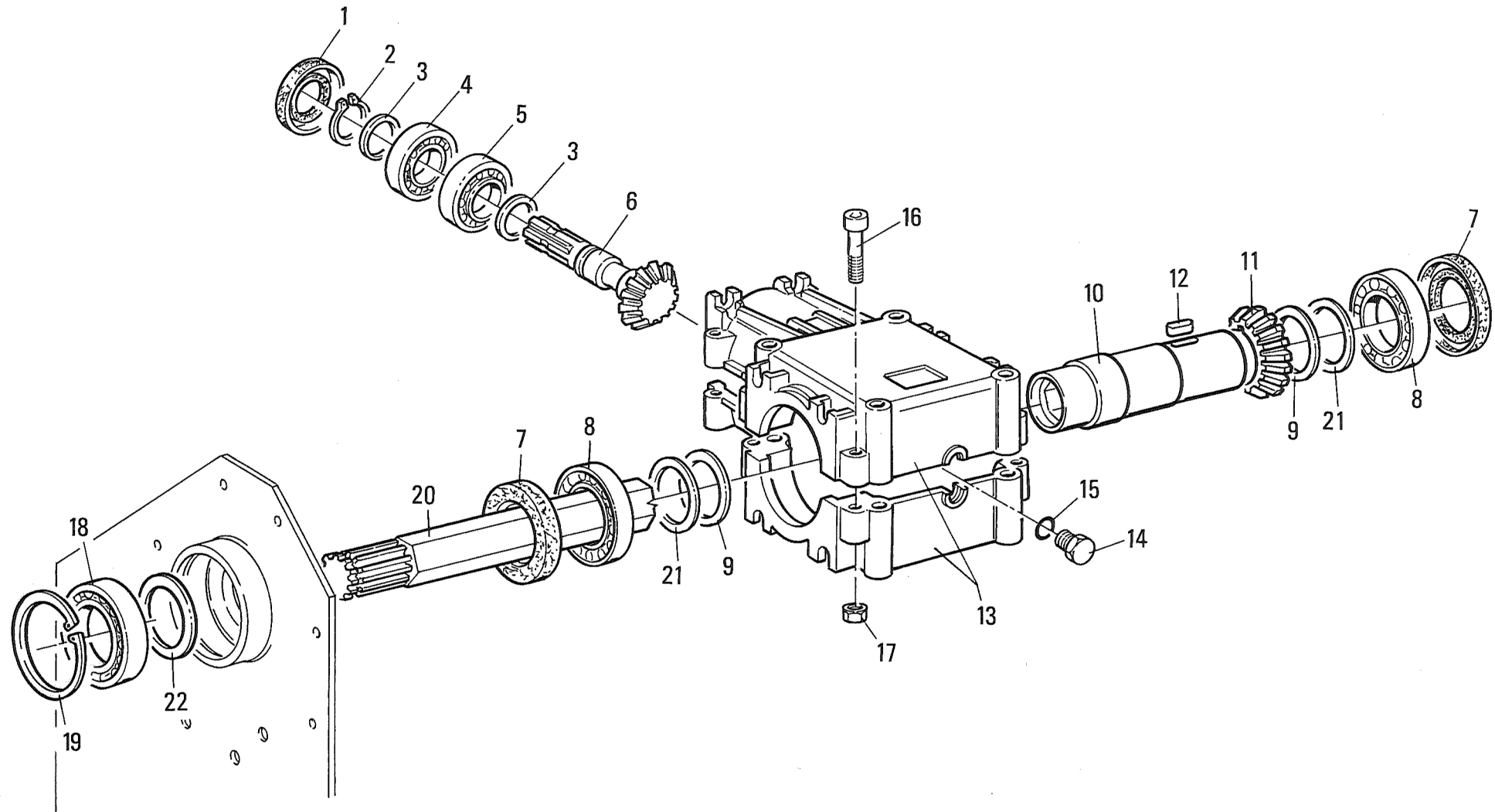

fino matricola - jusqu' au nr. serie - bis Seriennr. - up to serial nr. **32400**

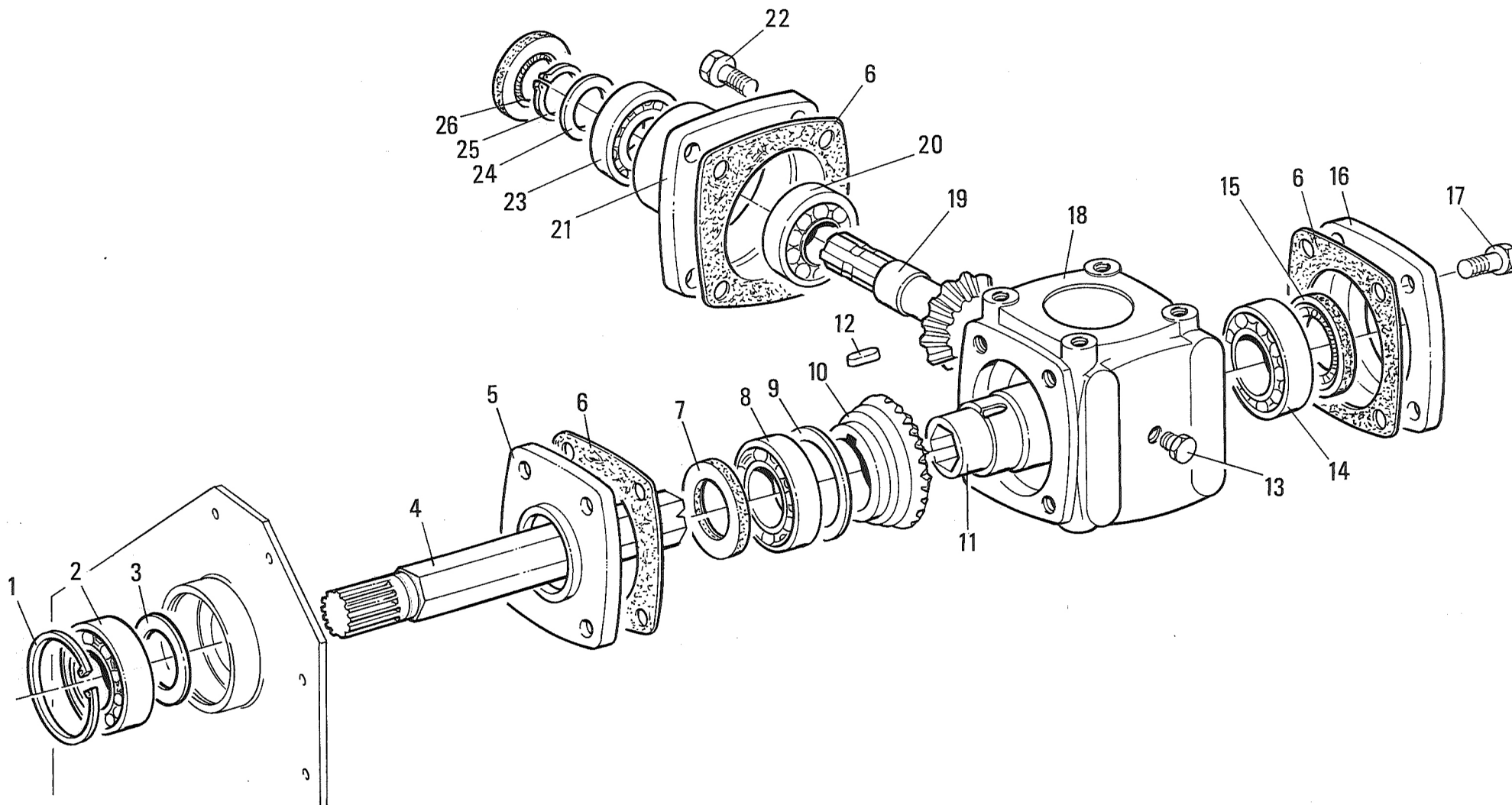

MURATORI MM

TAV. 4.0

POS.	N°	CODICE Q.	DESCRIZIONE	DESIGNATION	BENENNUNG	DESCRIPTION	DESIGNAZIONE	Da matr.	Fino matr.
								De nr. serie Vom Seriennr. From serial nr.	Jusqu'au nr. serie Bis Seriennr. Up to serial nr.
1	63001700	1	ANELLO ELASTICO	ARRETOIR	SPANNRING	SNAP-RING	Ø 62 I UNI 7437		
2	67006400	1	CUSCINETTO	ROULEMENT	LAGER	BEARING	6206 2RS		
3	68011200	1	SPESSORE	EPAISSEUR	DICKE	THICKNESS	62 x 50 x 1		
4	38010800	1	SEMIASSE	DEMI-ESSIEU	ACHSWELLE	AXLE SHAFT	MM 085		
4	38011000	1	SEMIASSE	DEMI-ESSIEU	ACHSWELLE	AXLE SHAFT	MM 105		
4	38011100	1	SEMIASSE	DEMI-ESSIEU	ACHSWELLE	AXLE SHAFT	MM 115		
4	38011200	1	SEMIASSE	DEMI-ESSIEU	ACHSWELLE	AXLE SHAFT	MM 125		
5	01008500	1	COPERCHIO	COUVERCLE	DECKEL	COVER			32400
6	80006500	3	GUARNIZIONE	GARNITURE	DICHTUNG	SEAL			18917
6	80006500	2	GUARNIZIONE	GARNITURE	DICHTUNG	SEAL		18918	32400
7	66003900	1	ANELLO TENUTA	JOINT D'ETANCHEITE	DICHTUNGSRING	JUNT RING	65 x 50 x 8		18917
7	66008400	1	ANELLO TENUTA	JOINT D'ETANCHEITE	DICHTUNGSRING	JUNT RING	62 x 40 x 7	18918	32400
8	67006600	1	CUSCINETTO	ROULEMENT	LAGER	BEARING	6010		18917
8	67004400	1	CUSCINETTO	ROULEMENT	LAGER	BEARING	6208	18918	32400
9	68013000	1	SPESSORE	EPAISSEUR	DICKE	THICKNESS	80 x 63 x 1		18917
10	10017100	1	CORONA	COURONNE	KRANZ	CROWN	Z 19 M5		18917
10	10022400	1	CORONA	COURONNE	KRANZ	CROWN	Z 19 M5	18918	32400
10	10034400	1	CORONA	COURONNE	KRANZ	CROWN	Z 41 2000 R.P.M.		32400
11	32061700	1	CANOTTO	TUBE	ROHR	TUBE			18917
11	32065100	1	CANOTTO	TUBE	ROHR	TUBE		18918	32400
12	65001700	1	LINGUETTA	CLAVETTE	KEIL	KEY	12 x 8 x 25 UNI 6604		18917
12	65001200	1	LINGUETTA	CLAVETTE	KEIL	KEY	8 x 7 x 25 UNI 6604	18918	32400
13	68002900	1	TAPPO	BOUCHON	STOPFEN	PLUG	3/8" CONICO		32400
14	67006600	1	CUSCINETTO	ROULEMENT	LAGER	BEARING	6010		18917
14	67004400	1	CUSCINETTO	ROULEMENT	LAGER	BEARING	6208	18918	32400
15	66003900	1	ANELLO TENUTA	JOINT D'ETANCHEITE	DICHTUNGSRING	JUNT RING	65 x 50 x 8		18917

fino matricola - jusqu' au nr. serie - bis Seriennr. - up to serial nr. **32400**

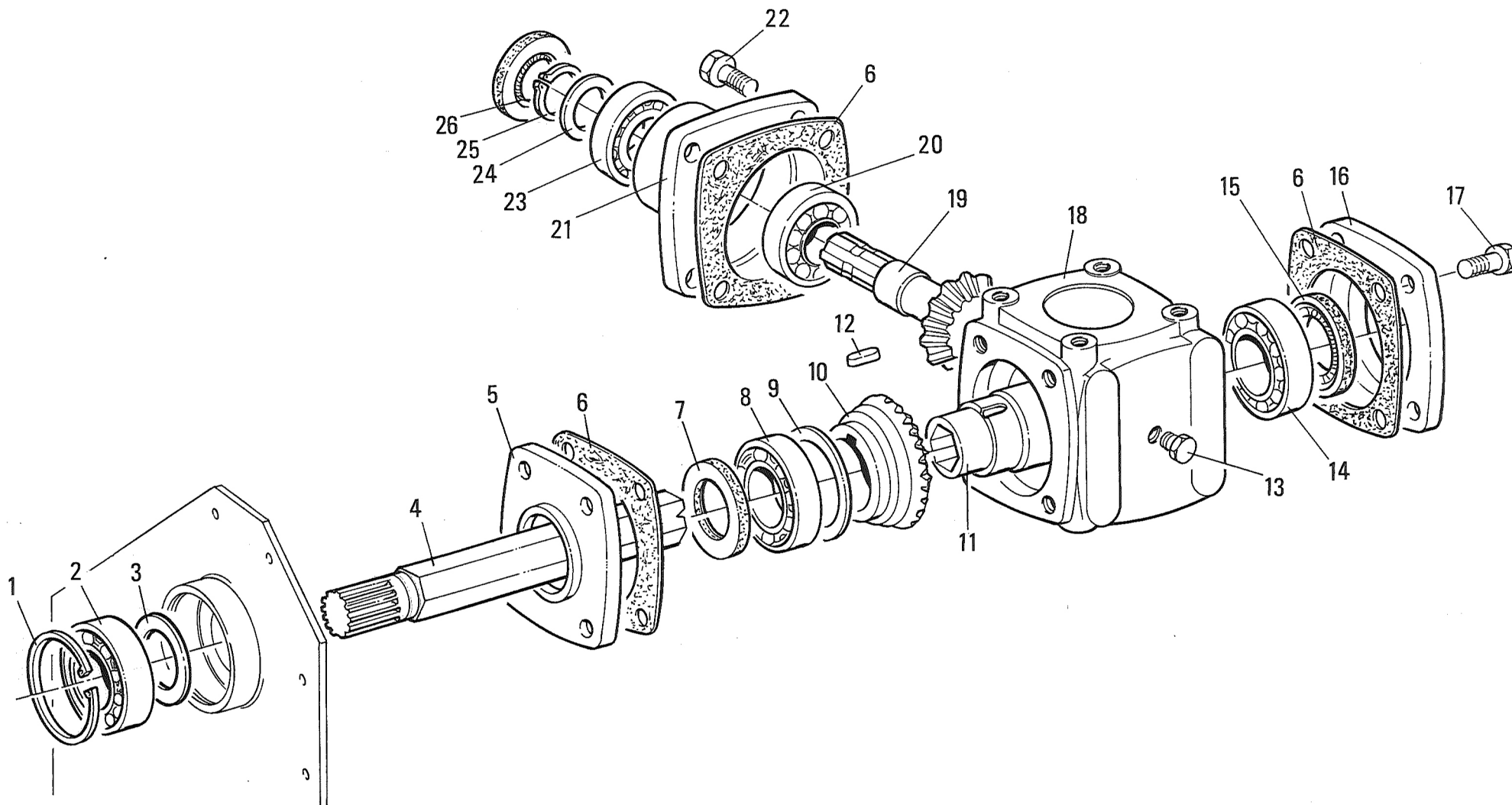



MURATORI S.p.A.

Via Pavarello, 21 - 41051 Castelnuovo Rangone (MO) Italy - Tel. 059.5330611 Fax 059.537259

www.muratoriequip.it *info@muratoriequip.it*

Capitale sociale Euro 480.000 interamente versato

Registro Imprese di Modena

Codice fiscale e numero d'iscrizione: 00708860366