

MURATORI

TIPO-TYPE-TYP
MT 12

CATALOGO RICAMBI
Catalogue Pièces Detachées
Ersatzteilkatalog
Spare Parts Catalogue
Catálogo Recambios

EDIZIONE 07/2003

Per ordinare parti di ricambio specificare:

- tipo e matricola della macchina (apposti sulla macchina o sui documenti di acquisto);
- numero del riferimento del pezzo nel disegno (Pos.), numero della tavola (Tav.) e numero di codice

N.B.: le indicazioni destro o sinistro vengono date guardando la macchina da dietro.

Pour les commandes de pièces de rechange veuillez spécifier:

- *type et numéro de serie de la machine (indiqués sur la machine et sur le bon d'achat);*
- *numéro de référence du pièce sur le plan (Pos.), numéro du plan (Tav.) et numero de code (codice)*

N.B.: *les indications droite ou gauche sont données en regardant la machine par derrière.*

Zum Bestellen von Ersatzteilen folgendes angeben:

- *Typ und Serien-Nr. der Maschine (zu finden auf der Maschine oder der Einkaufspapieren);*
- *Bezug-Nr. des Ersatzteils auf der Zeichnung (Pos.), Zeichnungsnummer (Tav.) und Kodenummer (codice)*

N.B.: *Die Angaben rechts und links verstehen sich so, dass man hinter der Maschine steht.*

When ordering spare parts specify:

- machine type and serial number (found on the machine or on the purchasing documents);
- reference number of the part on the relative drawing (Pos.), number of the drawing (Tav.) and part number (codice)

N.B.: right-hand or left-hand indications are made by viewing the machine from the rear.

TAV. 1.0

- GRUPPO TELAIO
- ENSEMBLE CHASSIS
- SATZ FÜR RAHMEN
- KIT FOR FRAME

TAV. 2.0 1/3

- ACCESSORI A COMPLETAMENTO
- OPTIONS D'ACHEVEMENT
- ZUBEHÖRE ZUR ERGANZUNG DER MASCHINE
- CHOICE OF EQUIPMENT COMPLETING MACHINE

TAV. 2.0 2/3

- ACCESSORI A COMPLETAMENTO
- OPTIONS D'ACHEVEMENT
- ZUBEHÖRE ZUR ERGANZUNG DER MASCHINE
- CHOICE OF EQUIPMENT COMPLETING MACHINE

TAV. 2.0 3/3

- ACCESSORI A COMPLETAMENTO
- OPTIONS D'ACHEVEMENT
- ZUBEHÖRE ZUR ERGANZUNG DER MASCHINE
- CHOICE OF EQUIPMENT COMPLETING MACHINE

TAV. 3.0

- GRUPPO RULLO ROTORE
- ENSEMBLE ROTOR
- SATZ FÜR ROTOR
- KIT FOR ROTOR

TAV.4.0

- GRUPPO MOLTIPLICATORE A 1 VELOCITA'
- ENSEMBLE BOITIER MONOVITESSE
- SATZ FÜR EINGANGGETRIEBE
- KIT FOR ONE-SPEED GEAR BOX

TAV. 5.0

- GRUPPO RULLO POSTERIORE
- ENSEMBLE ROULEAU ARRIERE
- SATZ HINTERE WALZE
- KIT REAR ROLLER

TAV. 6.0

- PROTEZIONI ANTINFORTUNISTICHE "CE"
- PROTECTIONS "CE"
- UNFALLSCHUTZVORRICHTUNGEN "CE"
- SAFETY GUARDS "CE"

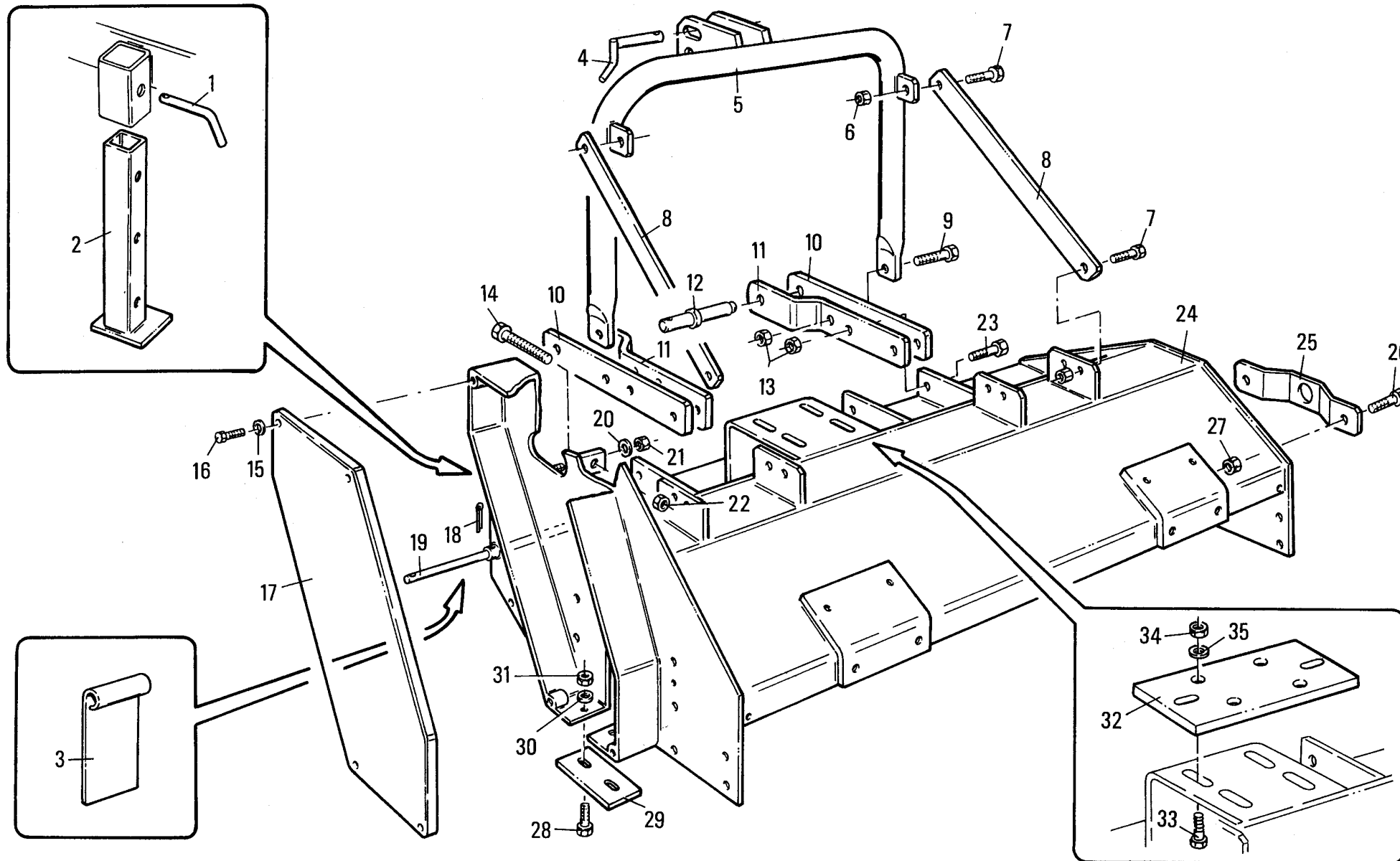

MURATORI MT 12

TAV. 1.0

POS.	N°	CODICE	Q	DESCRIZIONE	DESIGNATION	BENENNUNG	DESCRIPTION	DESIGNAZIONE	Da matr.	Fino matr
									De nr. serie	Jusqu'au nr. serie
									Vom Seriennr.	Bis Seriennr.
									From serial nr.	Up to serial nr.
1	31047300	1		PERNO	PIVOT	BOLZEN	PIN			56265
2	40143900	1		PIEDE	PIED	FUSS	FOOT			56265
3	39128400			BANDELLA	BANDE	BAND	STRAP	L = 70		
3	39164300			BANDELLA	BANDE	BAND	STRAP	L = 45		
3	39164200			BANDELLA	BANDE	BAND	STRAP	L = 35		
3	39164100			BANDELLA	BANDE	BAND	STRAP	L = 25		
4	68062000	1		PERNO	PIVOT	BOLZEN	PIN			
5	40142900	1		TELAIO	CHASSIS	RAHMEN	FRAME			52219
5	40170300	1		TELAIO	CHASSIS	RAHMEN	FRAME		52220	
6	62010600	4		DADO	ECROU	MUTTER	NUT	M 12 x 1,75 AUTOBLOCC.		
7	60021200	4		VITE	VIS	SCHRAUBE	SCREW	TE 12 x 35 UNI 5739		
8	30112500	2		TIRANTE	TIRANT	STANGE	TIEROD			52219
8	30135100	2		TIRANTE	TIRANT	STANGE	TIEROD		52220	
9	60031200	2		VITE	VIS	SCHRAUBE	SCREW	TE 16 x 110 UNI 5737		52219
9	60027100	2		VITE	VIS	SCHRAUBE	SCREW	TE 16 x 60 UNI 5737	52220	
10	30092501	2		STAFFA	BRIDE	BUEGEL	BRACKET			52219
10	30135000	2		STAFFA	BRIDE	BUEGEL	BRACKET		52220	
11	30092601	2		STAFFA	BRIDE	BUEGEL	BRACKET			52219
11	30134900	2		STAFFA	BRIDE	BUEGEL	BRACKET		52220	
12	68062300	2		PERNO	PIVOT	BOLZEN	PIN			
13	62008900	6		DADO	ECROU	MUTTER	NUT	M 16 x 2 UNI 5588		
14	60029300	1		VITE	VIS	SCHRAUBE	SCREW	TE 16 x 1,5 x 110 UNI 5740		
15	61006200	4		RONDELLA	RONDELLE	SCHEIBE	WASHER	PIANA Øi9 Øe24		
16	60015100	4		VITE	VIS	SCHRAUBE	SCREW	TE 8 x 16 UNI 5739		
17	39160600	1		COPERCHIO	COUVERCLE	DECKEL	COVER			
18	64003700	1		COPIGLIA	COUPILLE	SPLINT	COTTER PIN	3 x 40 UNI 1336		

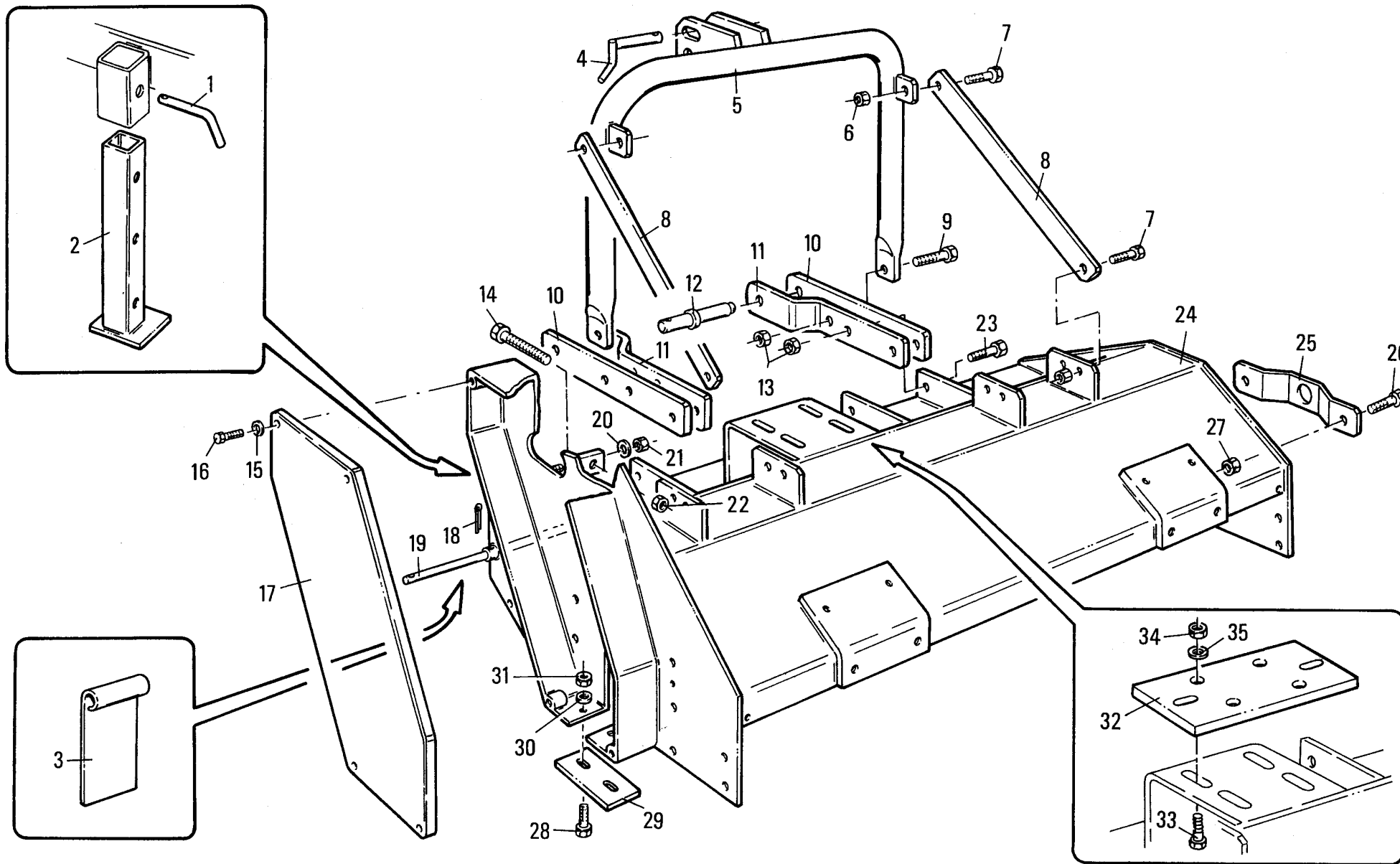

MURATORI MT 12

TAV. 1.0

POS.	N° CODICE	Q	DESCRIZIONE	DESIGNATION	BENENNUNG	DESCRIPTION	DESIGNAZIONE	Da matr.	Fino matr
								De nr. serie	Jusqu'au nr. serie
								Vom Seriennr.	Bis Seriennr.
								From serial nr.	Up to serial nr.
19	31049400	1	SPINA	GOUPILLE	STIFT	PIN	100		56265
19	31049500	1	SPINA	GOUPILLE	STIFT	PIN	115		56265
19	31049600	1	SPINA	GOUPILLE	STIFT	PIN	130		56265
19	31049700	1	SPINA	GOUPILLE	STIFT	PIN	160		56265
19	31049800	1	SPINA	GOUPILLE	STIFT	PIN	190		56265
19	31049401	1	SPINA	GOUPILLE	STIFT	PIN	100	56266	
19	31049501	1	SPINA	GOUPILLE	STIFT	PIN	115	56266	
19	31049601	1	SPINA	GOUPILLE	STIFT	PIN	130	56266	
19	31049701	1	SPINA	GOUPILLE	STIFT	PIN	160	56266	
19	31049801	1	SPINA	GOUPILLE	STIFT	PIN	190	56266	
20	61005000	1	RONDELLA	RONDELLE	SCHEIBE	WASHER	PIANA Ø12 UNI 6592		
21	62010600	1	DADO	ECROU	MUTTER	NUT	M 12 x 1,75 AUTOBLOCC.		
22	62003300	2	DADO	ECROU	MUTTER	NUT	M 16 x 1,5 UNI 5588		
23	60027100	4	VITE	VIS	SCHRAUBE	SCREW	TE 16 x 60 UNI 5737		
24	41084900	1	TELAIO	CHASSIS	RAHMEN	FRAME	100		56265
24	41085000	1	TELAIO	CHASSIS	RAHMEN	FRAME	115		56265
24	41085100	1	TELAIO	CHASSIS	RAHMEN	FRAME	130		56265
24	41085200	1	TELAIO	CHASSIS	RAHMEN	FRAME	160		56265
24	41085300	1	TELAIO	CHASSIS	RAHMEN	FRAME	190		56265
24	41101200	1	TELAIO	CHASSIS	RAHMEN	FRAME	100	56266	
24	41101300	1	TELAIO	CHASSIS	RAHMEN	FRAME	115	56266	
24	41101400	1	TELAIO	CHASSIS	RAHMEN	FRAME	130	56266	
24	41101500	1	TELAIO	CHASSIS	RAHMEN	FRAME	160	56266	
24	41101600	1	TELAIO	CHASSIS	RAHMEN	FRAME	190	56266	
25	30119900	1	PROTEZIONE	PROTECTION	SCHUTZ	GUARD			
26	60023200	2	VITE	VIS	SCHRAUBE	SCREW	TE 14 x 35 UNI 5739		

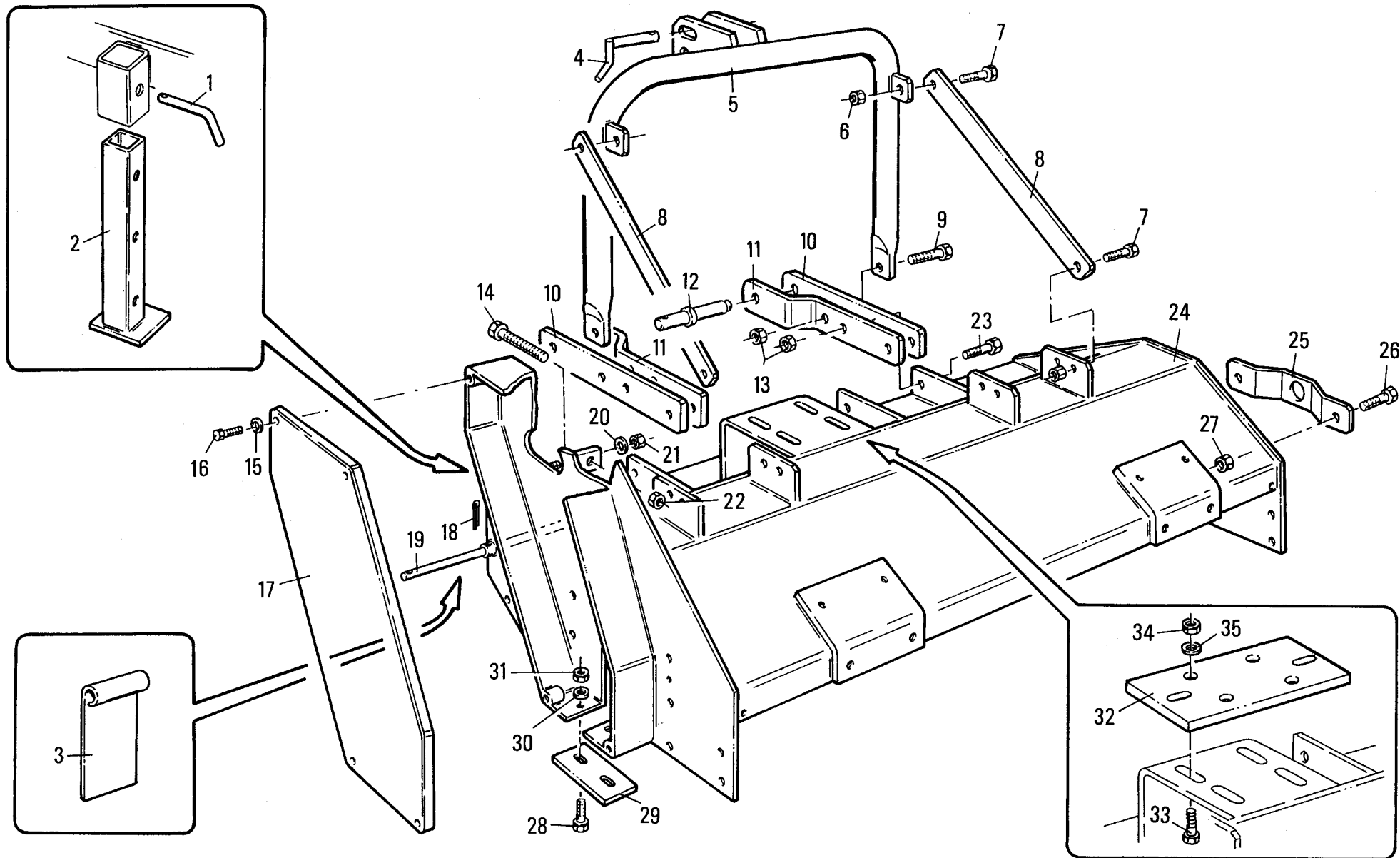

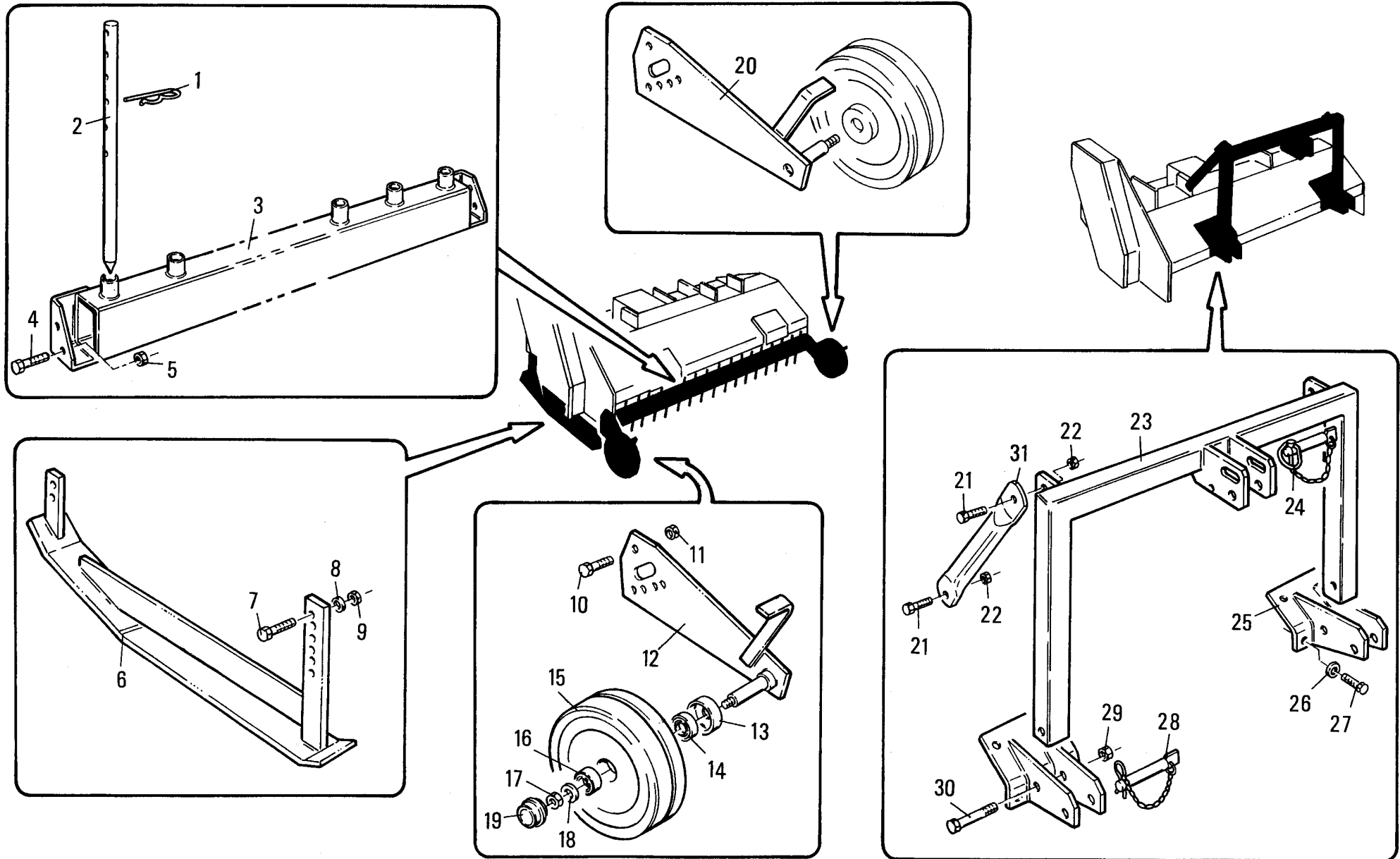

MURATORI MT 12

TAV. 2.0 1/3

POS.	N° CODICE Q	DESCRIZIONE	DESIGNATION	BENENNUNG	DESCRIPTION	DESIGNAZIONE	Da matr.	Fino matr
							De nr. serie Vom Seriennr. From serial nr.	Jusqu'au nr. serie Bis Seriennr. Up to serial nr.
1	64000300	COPIGLIA	COUPILLE	SPLINT	COTTER PIN	AR Ø4		
2	38016500	ASTA	TIGE	STANGE	ROD			
3	40144000	1 SUPPORTO	SUPPORT	TRAEGER	SUPPORT	100		56265
3	40144100	1 SUPPORTO	SUPPORT	TRAEGER	SUPPORT	115		56265
3	40144200	1 SUPPORTO	SUPPORT	TRAEGER	SUPPORT	130		56265
3	40144300	1 SUPPORTO	SUPPORT	TRAEGER	SUPPORT	160		56265
3	40144400	1 SUPPORTO	SUPPORT	TRAEGER	SUPPORT	190		56265
4	60031300	4 VITE	VIS	SCHRAUBE	SCREW	TE 14 x 45 UNI 5739		56265
5	62010800	4 DADO	ECROU	MUTTER	NUT	M 14 x 2 AUTOBLOCC.		56265
6	40200000	2 SLITTA	PATIN	STUTZTKUFE	SKID			56265
6	40209700	2 SLITTA	PATIN	STUTZTKUFE	SKID		56266	
7	60026400	4 VITE	VIS	SCHRAUBE	SCREW	TE 14 x 40 UNI 5739		
8	61006700	4 RONDELLA	RONDELLE	SCHEIBE	WASHER	GROWER Ø14 UNI 1751		
9	62008700	4 DADO	ECROU	MUTTER	NUT	M 14 x 2 UNI 5588		
10	60023200	4 VITE	VIS	SCHRAUBE	SCREW	TE 14 x 35 UNI5739		
11	62010800	4 DADO	ECROU	MUTTER	NUT	M 14 x 2 AUTOBLOCC.		
12	40170900	1 SUPPORTO SX	SUPPORT (G)	TRAEGER (LINKS)	SUPPORT (LH)			
13	68072400	2 PARAPOLVERE	PARE-POUSSIÈRE	STAUBDECKEL	DUST COVER			
14	67016900	2 CUSCINETTO	ROULEMENT	LAGER	BEARING	6204 Z		
15	68072200	2 RUOTA	ROUE	RAD	WHEEL			
16	67016800	2 CUSCINETTO	ROULEMENT	LAGER	BEARING	6303		
17	61006600	2 RONDELLA	RONDELLE	SCHEIBE	WASHER	PIANA Ø 14 UNI 6592		
18	62010700	2 DADO	ECROU	MUTTER	NUT	M 14 x 1,5 AUTOBLOCC.		
19	68072300	2 PARAPOLVERE	PARE-POUSSIÈRE	STAUBDECKEL	DUST COVER			
20	40171000	1 SUPPORTO DX	SUPPORT (D)	TRAEGER (RECHTS)	SUPPORT (RH)			
21	60021200	4 VITE	VIS	SCHRAUBE	SCREW	TE 12 x 35 UNI 5739		

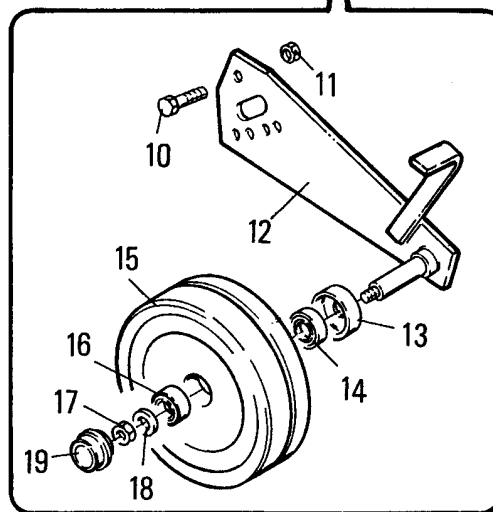
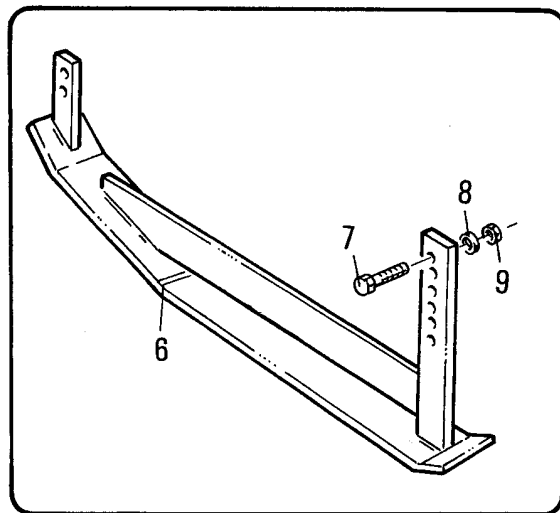
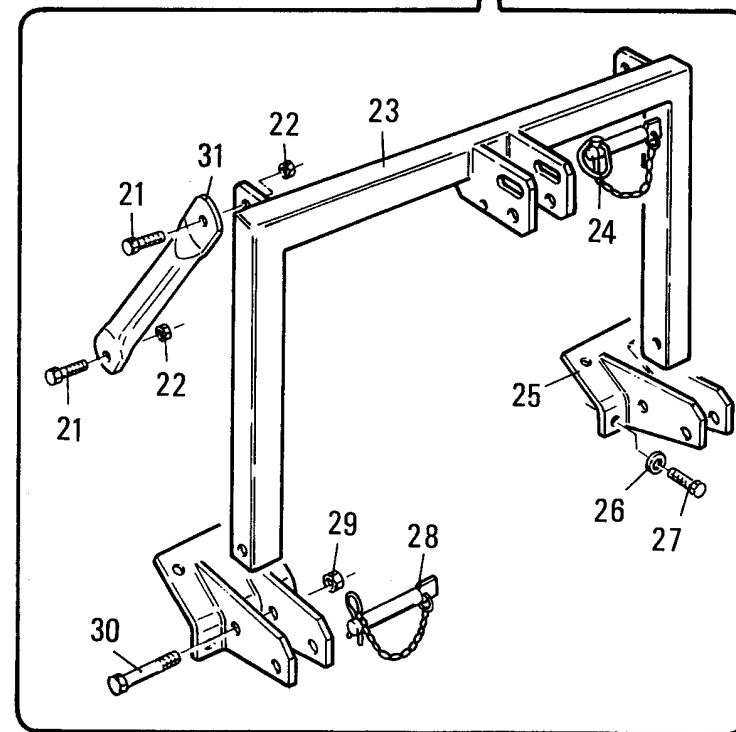
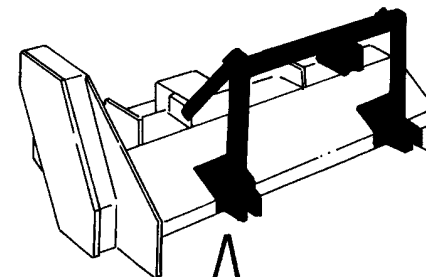
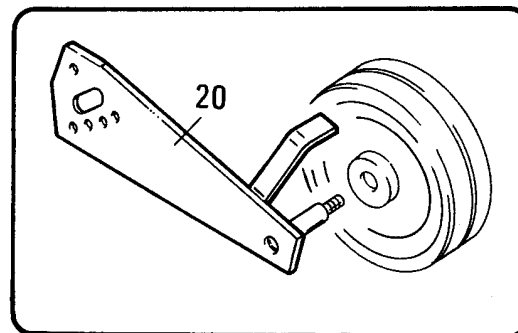
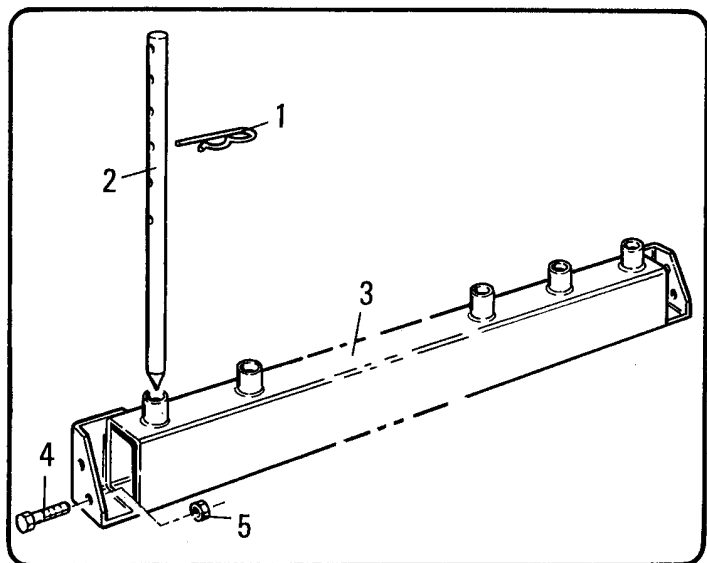

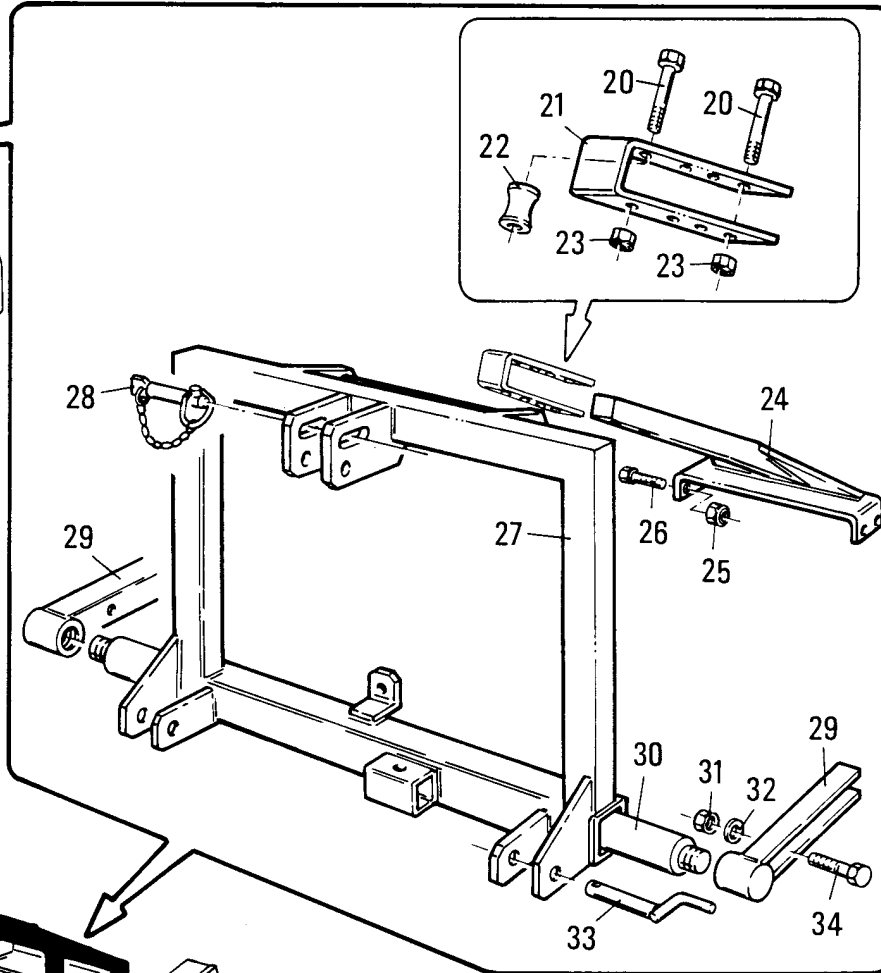
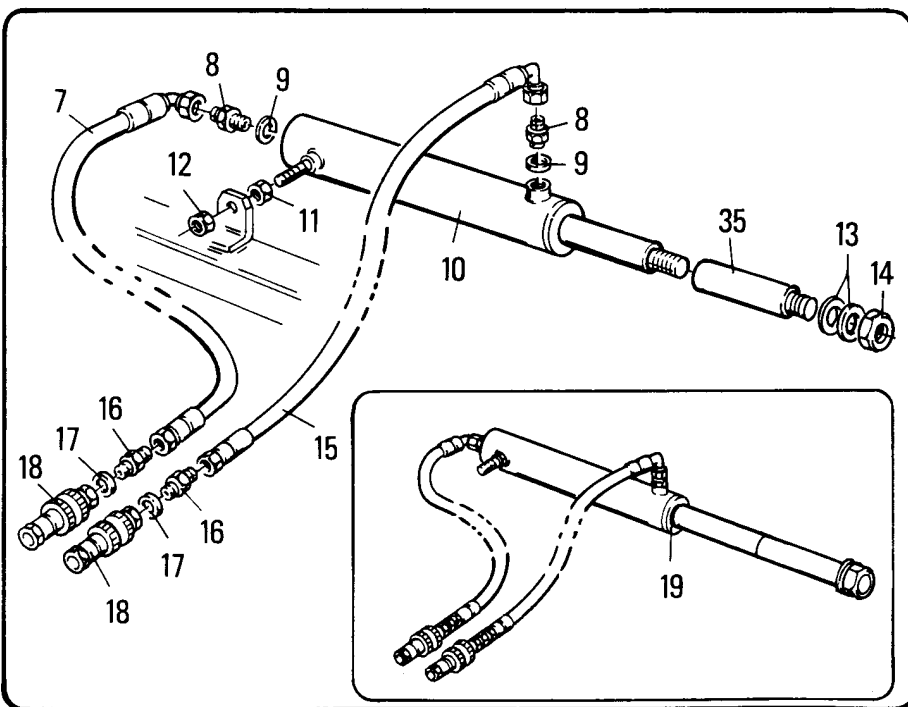
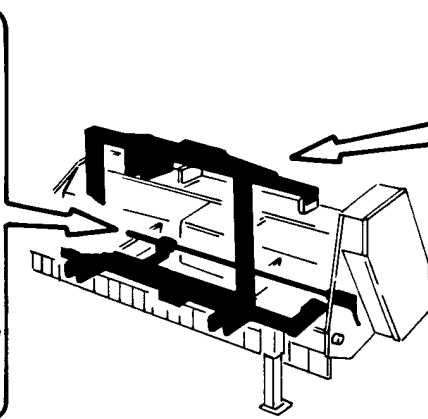
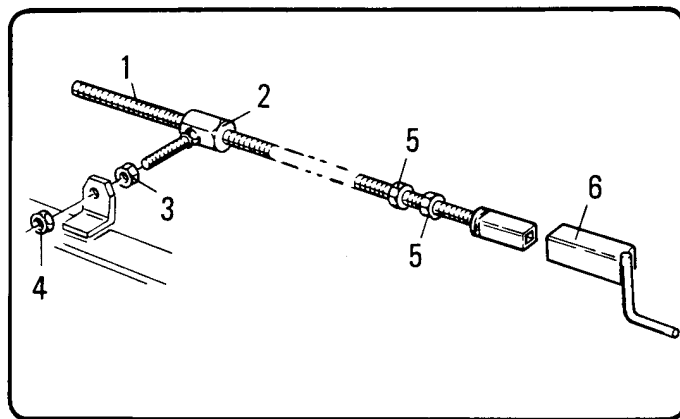

MURATORI MT 12

TAV. 2.0 2/3

POS.	N° CODICE	Q	DESCRIZIONE	DESIGNATION	BENENNUNG	DESCRIPTION	DESIGNAZIONE	Da matr.	Fino matr
								De nr. serie	Jusqu'au nr. serie
								Vom Seriennr.	Bis Seriennr.
								From serial nr.	Up to serial nr.
1	40247000	1	VITE	VIS	SCHRAUBE	SCREW			
2	40246900	1	CHIOCCIOLA	ECROU EN CARACOLE	SPINDEL	LEAD NUT			
3	62001100	1	DADO	ECROU	MUTTER	NUT	M 12x 1,75 UNI 5589		
4	62010600	1	DADO	ECROU	MUTTER	NUT	M 12 x 1,75 AUTOBLOCC.		
5	62014700	2	CHIOCCIOLA	ECROU EN CARACOLE	SPINDEL	LEAD NUT			
6	40121700	1	MANOVELLA	MANIVELLE	KURBEL	CRANK			
7	68048400	1	TUBO	TUBE	ROHR	TUBE	SAE 100 1/4" L = 2500		
8	68048200	2	NIPPLO	RACCORD	NIPPEL	NIPPLE	1/4 "		
9	61007100	2	RONDELLA	RONDELLE	SCHEIBE	WASHER	RAME 1/4"		
10	68065500	1	CILINDRO	CYLINDRE	ZYLINDER	CYLINDER	130		56265
10	68049502	1	CILINDRO	CYLINDRE	ZYLINDER	CYLINDER	160		56265
10	68049602	1	CILINDRO	CYLINDRE	ZYLINDER	CYLINDER	190		56265
10	68065500	1	CILINDRO	CYLINDRE	ZYLINDER	CYLINDER	130-190	56266	
11	62001100	1	DADO	ECROU	MUTTER	NUT	M 12 x 1,75 UNI 5589		
12	62010600	1	DADO	ECROU	MUTTER	NUT	M 12 x 1,75 AUTOBLOCC.		
13	61007000	2	RONDELLA	RONDELLE	SCHEIBE	WASHER	PIANAØi21 Øe37		
14	62011300	1	DADO	ECROU	MUTTER	NUT	M 20 x 1,5 AUTOBLOCC.		
15	68048300	1	TUBO	TUBE	ROHR	TUBE	SAE 100 1/4" L = 2000		
16	68048700	2	NIPPLO	RACCORD	NIPPEL	NIPPLE	1/4" - 1/2"		
17	61005700	2	RONDELLA	RONDELLE	SCHEIBE	WASHER	RAME 1/2"		
18	68043500	2	ATTACCO RAPIDO	ATTELAGE RAPIDE	SCHNELLKUPPLUNG	QUICKLINKAGE	SPIILLO 1/2"		
19	45069700	1	CILINDRO	CYLINDRE	ZYLINDER	CYLINDER	130		
19	45069800	1	CILINDRO	CYLINDRE	ZYLINDER	CYLINDER	160		
19	45069900	1	CILINDRO	CYLINDRE	ZYLINDER	CYLINDER	190		
20	60024400	4	VITE	VIS	SCHRAUBE	SCREW	TE 12 x 70UNI 5737		
21	30113600	1	STAFFA	BRIDE	BUEGEL	BRACKET			

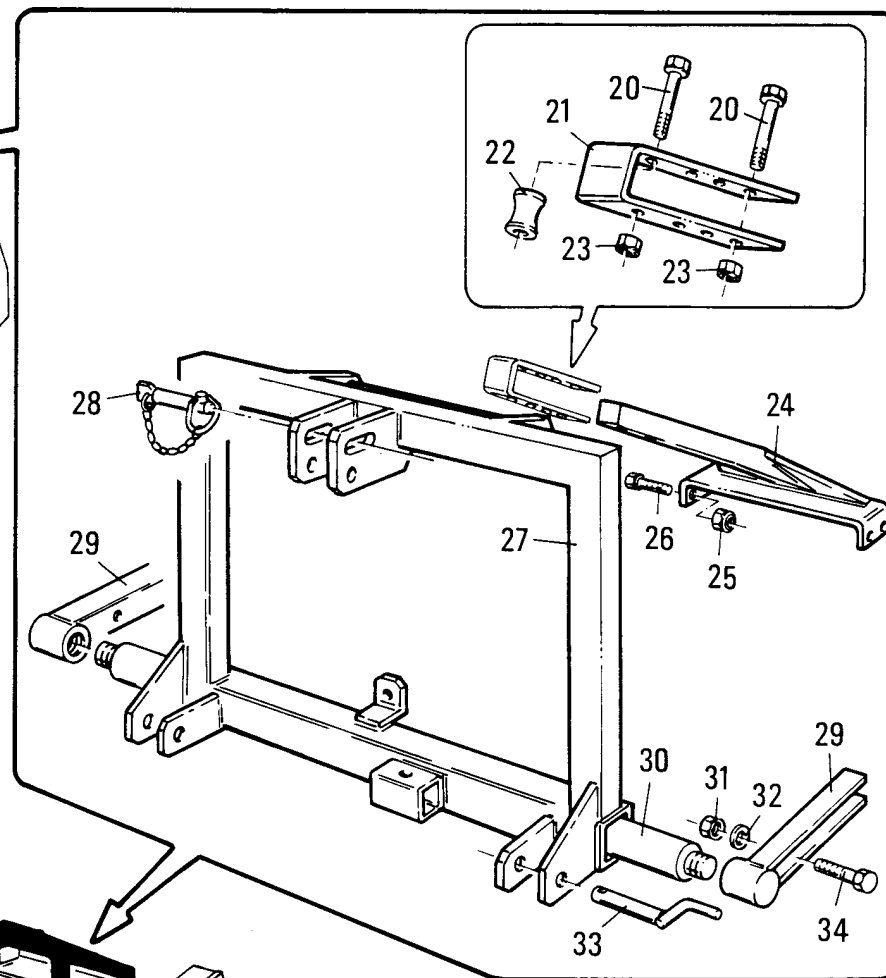
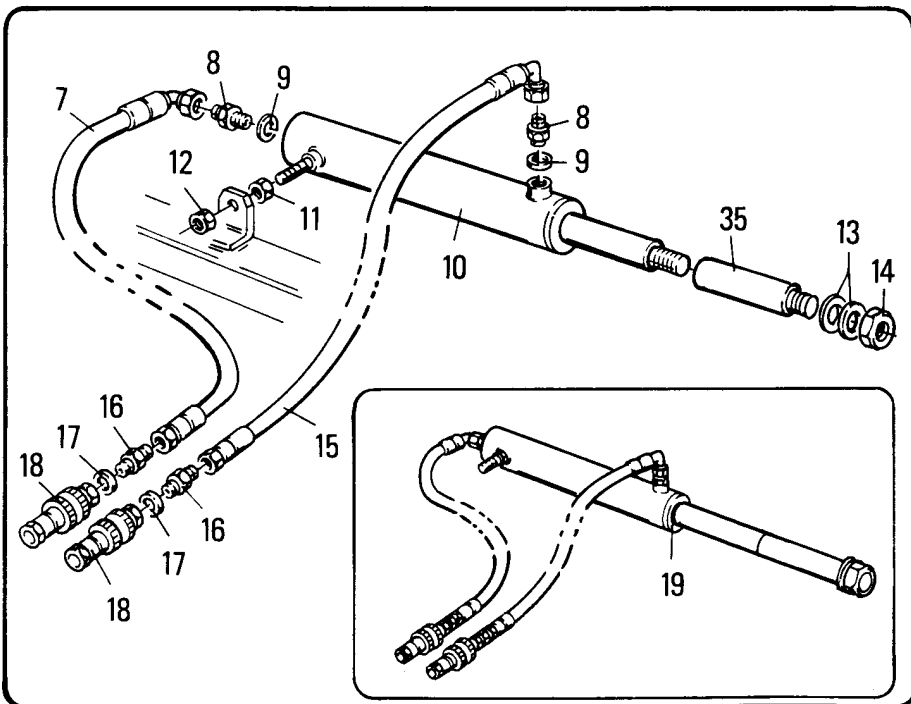
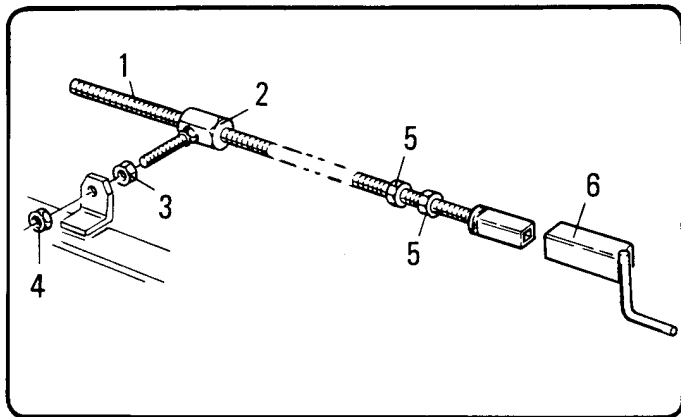

MURATORI MT 12

TAV. 2.0 2/3

POS.	N°	CODICE	Q	DESCRIZIONE	DESIGNATION	BENENNUNG	DESCRIPTION	DESIGNAZIONE	Da matr.	Fino matr
									De nr. serie	Jusqu'au nr. serie
									Vom Seriennr.	Bis Seriennr.
									From serial nr.	Up to serial nr.
22	38018500	2	RULLINO	GALET	ROLLE	NEEDLE PIN				
23	62010600	4	DADO	ECROU	MUTTER	NUT	M 12 x 1,75 AUTOBLOCC.			
24	40154900	1	STAFFA	BRIDE	BUEGEL	BRACKET	130			53612
24	40143600	1	STAFFA	BRIDE	BUEGEL	BRACKET	160 - 190			53612
24	40171300	1	STAFFA	BRIDE	BUEGEL	BRACKET	130	53613		57258
24	40171200	1	STAFFA	BRIDE	BUEGEL	BRACKET	160 - 190	53613		57258
24	40171301	1	STAFFA	BRIDE	BUEGEL	BRACKET	130	57259		
24	40171201	1	STAFFA	BRIDE	BUEGEL	BRACKET	160	57259		
24	40211900	1	STAFFA	BRIDE	BUEGEL	BRACKET	190	57259		
25	62010600	4	DADO	ECROU	MUTTER	NUT	M 12 x 1,75 AUTOBLOCC.			
26	60030400	4	VITE	VIS	SCHRAUBE	SCREW	TE 12 x 40 UNI 5737			
27	40143500	1	TELAIO	CHASSIS	RAHMEN	FRAME				53612
27	40171100	1	TELAIO	CHASSIS	RAHMEN	FRAME		53613		
28	68062000	1	PERNO	PIVOT	BOLZEN	PIN				
29	40154800	2	STAFFA	BRIDE	BUEGEL	BRACKET	130			
29	40143400	2	STAFFA	BRIDE	BUEGEL	BRACKET	160 - 190			56265
29	40209600	2	STAFFA	BRIDE	BUEGEL	BRACKET	160 - 190	56266		
30	38018300	1	BARRA	BARRE	STANGE	BAR				
31	62003300	4	DADO	ECROU	MUTTER	NUT	M 16 x 1,5 UNI 5588			
32	61006400	4	RONDELLA	RONDELLE	SCHEIBE	WASHER	GROWER Ø16 UNI 1751			
33	68062300	2	PERNO	PIVOT	BOLZEN	PIN				
34	60029600	4	VITE	VIS	SCHRAUBE	SCREW	TE 16 x 1,5 x 40 UNI5740			
35	31082200	1	PROLUNGA	RALLONGE	VERLAENGERUNGSROHR	EXTENSION	160	56266		
35	31082300	1	PROLUNGA	RALLONGE	VERLAENGERUNGSROHR	EXTENSION	190	56266		

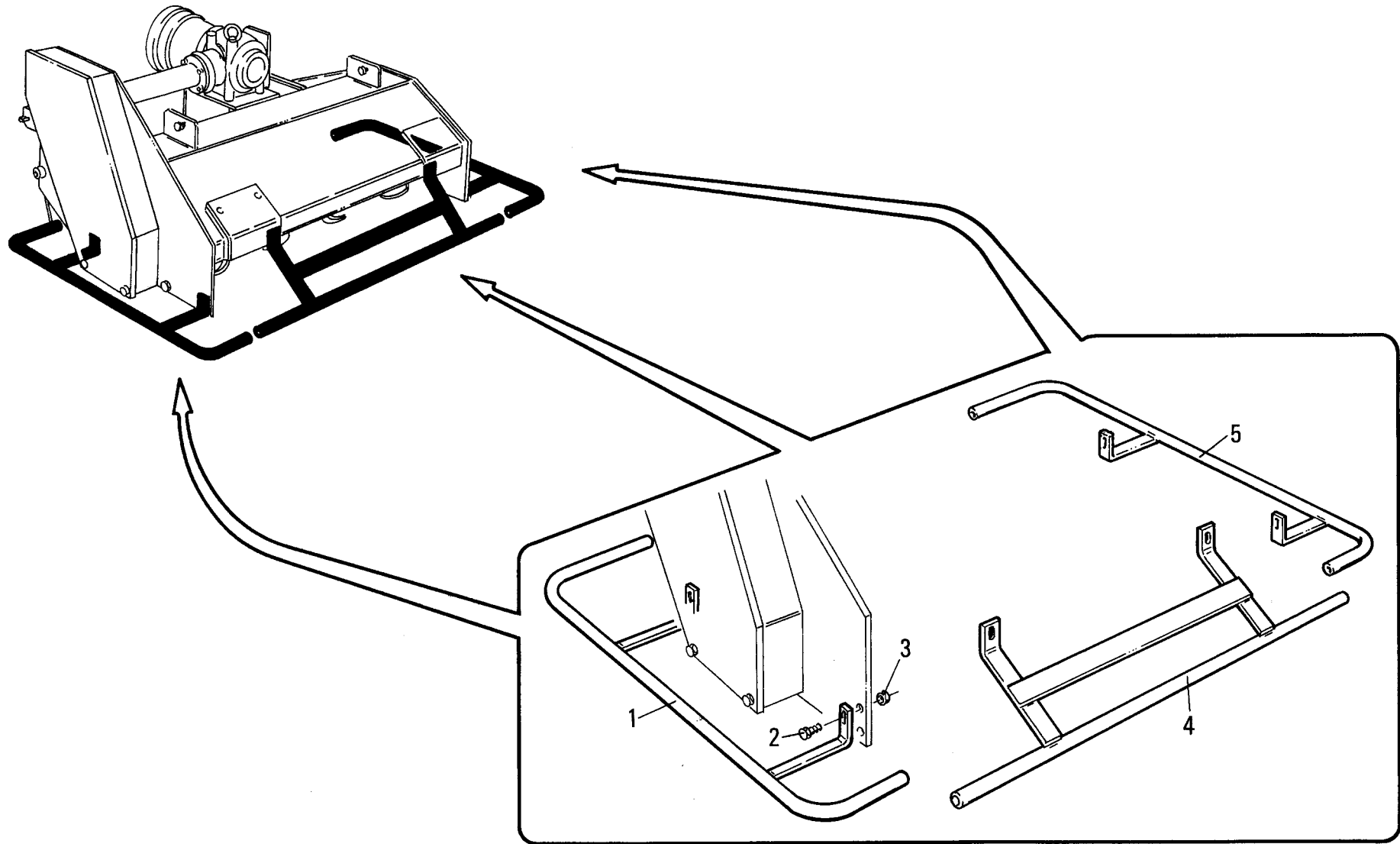

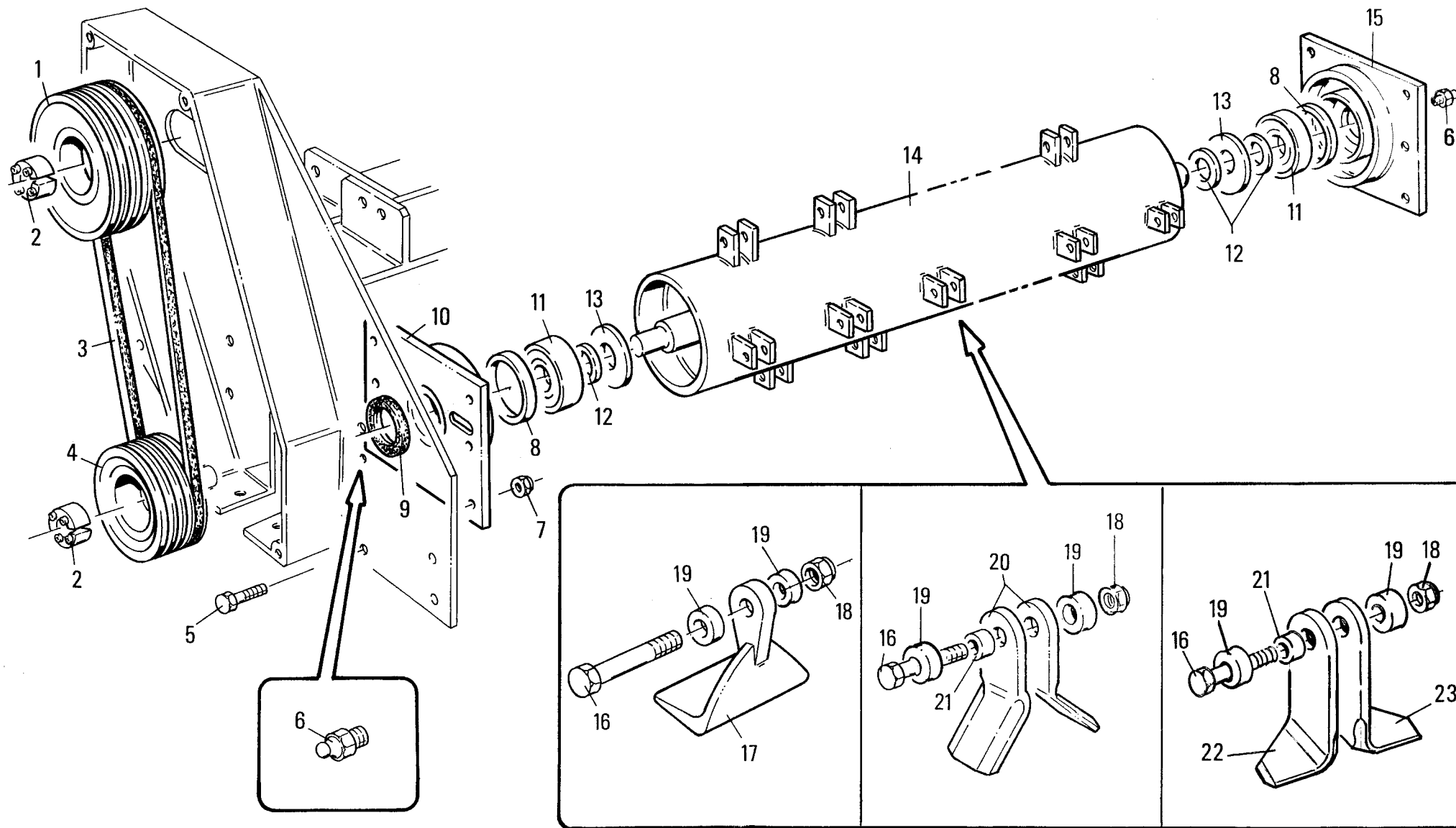

MURATORI MT 12
TAV. 3.0

POS.	N° CODICE	Q	DESCRIZIONE	DESIGNATION	BENENNUNG	DESCRIPTION	DESIGNAZIONE	Da matr.	Fino matr
								De nr. serie Vom Seriennr. From serial nr.	Jusqu'au nr. serie Bis Seriennr. Up to serial nr.
1	68059300	1	PULEGGIA	POULIE	RIEMENSCHLEIBE	PULLEY	Øe 160 (100-130) 2 SPB Øi 65		
1	68059600	1	PULEGGIA	POULIE	RIEMENSCHLEIBE	PULLEY	Øe 160 (160-190) 3 SPB Øi 65		
2	68059500	2	CALETTATORE	DISPOSITIV D'ASSEMBLA	SPANNSATZ	LOCKING DEVICE	Øe 65 Øi 40		
3	68060800		CINGHIA	COURROIE	KEILRIEMEN	BELT			
4	68059400	1	PULEGGIA	POULIE	RIEMENSCHLEIBE	PULLEY	Øe 130 (100-130) 2 SPB Øi 65		56265
4	68059700	1	PULEGGIA	POULIE	RIEMENSCHLEIBE	PULLEY	Øe 130 (160-190) 3 SPB Øi 65		56265
4	68079200	1	PULEGGIA	POULIE	RIEMENSCHLEIBE	PULLEY	Øe 120 (100-130) 2 SPB Øi 65	56266	
4	68079300	1	PULEGGIA	POULIE	RIEMENSCHLEIBE	PULLEY	Øe 120 (160-190) 3 SPB Øi 65	56266	
5	60026700	10	VITE	VIS	SCHRAUBE	SCREW	TE 14 x 30 UNI 5739		
6	64001800	2	INGRASSATORE	GRAISSEUR	SCHMIERNIPPEL	GREASE FITTING	M 10 x 1 DIRITTO		
7	62010800	10	DADO	ECROU	MUTTER	NUT	M 14 x 2 AUTOBLOCC.		
8	32097600	2	DISTANZIALE	ENTRETOISE	DISTANZSTUECK	SPACER			
9	66014100	1	ANELLO TENUTA	JOINT D'ETANCHEITE	DICHTUNGSRING	JUNT RING	45 x 65 x 6 "G"		
10	40120800	1	SUPPORTO SX	SUPPORT (G)	TRAEGER (LINKS)	SUPPORT (LH)			
11	67014500	2	CUSCINETTO	ROULEMENT	LAGER	BEARING	1309		
12	68011000		SPESSORE	EPAISSEUR	DICKE	THICKNESS	55 x 45 x 1		
13	39129100	2	PROTEZIONE	PROTECTION	SCHUTZ	GUARD			
14	42049600	1	ROTORE	ROTOR	ROTOR	ROTOR	100		
14	42049700	1	ROTORE	ROTOR	ROTOR	ROTOR	115		
14	42049800	1	ROTORE	ROTOR	ROTOR	ROTOR	130		
14	42049900	1	ROTORE	ROTOR	ROTOR	ROTOR	160		
14	42050000	1	ROTORE	ROTOR	ROTOR	ROTOR	190		
15	40120700	1	SUPPORTO DX	SUPPORT (D)	TRAEGER (RECHTS)	SUPPORT (RH)			
16	60003500		VITE	VIS	SCHRAUBE	SCREW	TE 14 x 60 UNI 5737	48726	
16	60012300		VITE	VIS	SCHRAUBE	SCREW	TE 14 x 90 UNI 5737		48725
17	12014400		MAZZA	MARTEAUX	HAMMER	HAMMER			

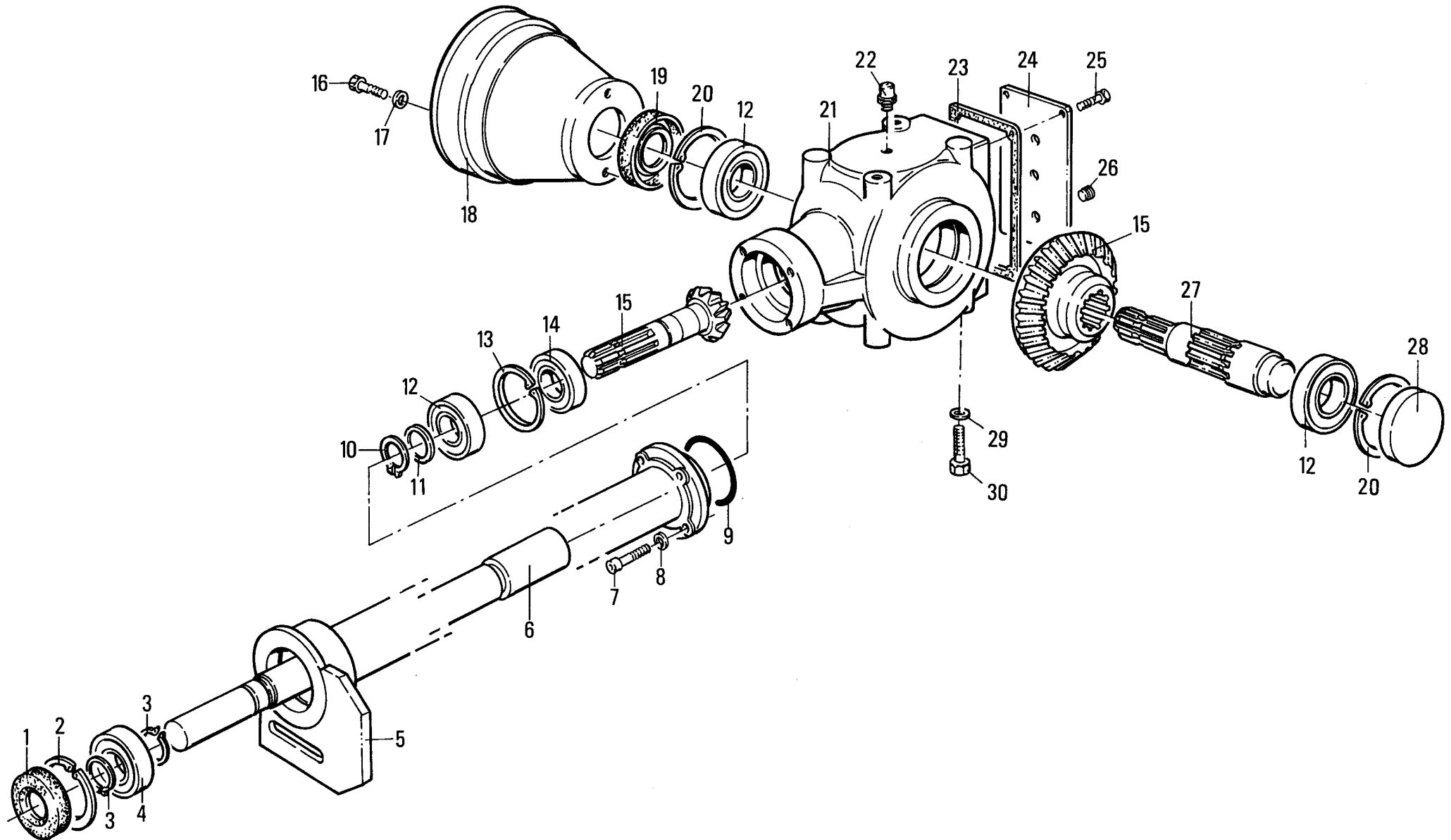

MURATORI MT 12

TAV. 4.0

POS.	N° CODICE	Q	DESCRIZIONE	DESIGNATION	BENENNUNG	DESCRIPTION	DESIGNAZIONE	Da matr.	Fino matr
								De nr. serie	Jusqu'au nr. serie
								Vom Seriennr.	Bis Seriennr.
								From serial nr.	Up to serial nr.
1	66009200	1	ANELLO TENUTA	JOINT D'ETANCHEITE	DICHTUNGSRING	JUNT RING	40 x 80 x 12		
2	63000200	1	ANELLO ELASTICO	ARRETOIR	SPANNRING	SNAP-RING	Ø 80 I		
3	63000700	2	ANELLO ELASTICO	ARRETOIR	SPANNRING	SNAP-RING	Ø 40 E		
4	67004400	1	CUSCINETTO	ROULEMENT	LAGER	BEARING	6208		
5	40179000	1	TUBO	TUBE	ROHR	TUBE	100 - 130		
5	40179100	1	TUBO	TUBE	ROHR	TUBE	160		
5	40179200	1	TUBO	TUBE	ROHR	TUBE	190		
6	31065100	1	ALBERO	ARBRE	WELLE	SHAFT	100 - 130		
6	31065200	1	ALBERO	ARBRE	WELLE	SHAFT	160		
6	31065300	1	ALBERO	ARBRE	WELLE	SHAFT	190		
7	60015300	4	VITE	VIS	SCHRAUBE	SCREW	TCEI 8 x 25 UNI 5931		
8	61000600	4	RONDELLA	RONDELLE	SCHEIBE	WASHER	DENT. INT. Ø 8 UNI 3704		
9	66014300	1	ANELLO TENUTA	JOINT D'ETANCHEITE	DICHTUNGSRING	JUNT RING	O.R. 3262		
10	63000600	1	ANELLO ELASTICO	ARRETOIR	SPANNRING	SNAP-RING	Ø 35 E		
11	68010200		SPESSORE	EPAISSEUR	DICKE	THICKNESS	45 x 35 x 0,2		
12	67003700	3	CUSCINETTO	ROULEMENT	LAGER	BEARING	6207		
13	63001700	1	ANELLO ELASTICO	ARRETOIR	SPANNRING	SNAP-RING	Ø 62 i		
14	67017200	1	CUSCINETTO	ROULEMENT	LAGER	BEARING	32007 X		
15	10036700	1	COPPIA CONICA	COUPLE CONIQUE	KEGELRADTRIEB.	BEVEL GEAR PAIR	Z 31 M 4,5 / Z10 M 4,5		
16	60015100	4	VITE	VIS	SCHRAUBE	SCREW	TE 8 x 16 UNI 5739		
17	61004700	4	RONDELLA	RONDELLE	SCHEIBE	WASHER	PIANA Ø 8 UNI 6592		
18	68061400	1	PROTEZIONE	PROTECTION	SCHUTZ	GUARD			
19	66014800	1	ANELLO TENUTA	JOINT D'ETANCHEITE	DICHTUNGSRING	JUNT RING	35 x 72 x 10 LABBRO PARAPOLV.		
20	63000300	2	ANELLO ELASTICO	ARRETOIR	SPANNRING	SNAP-RING	Ø 72I		
21	01015800	1	SCATOLA	CARTER	GEHAEUSE	GEARBOX			
22	68067500	1	TAPPO	BOUCHON	STOPFEN	PLUG			

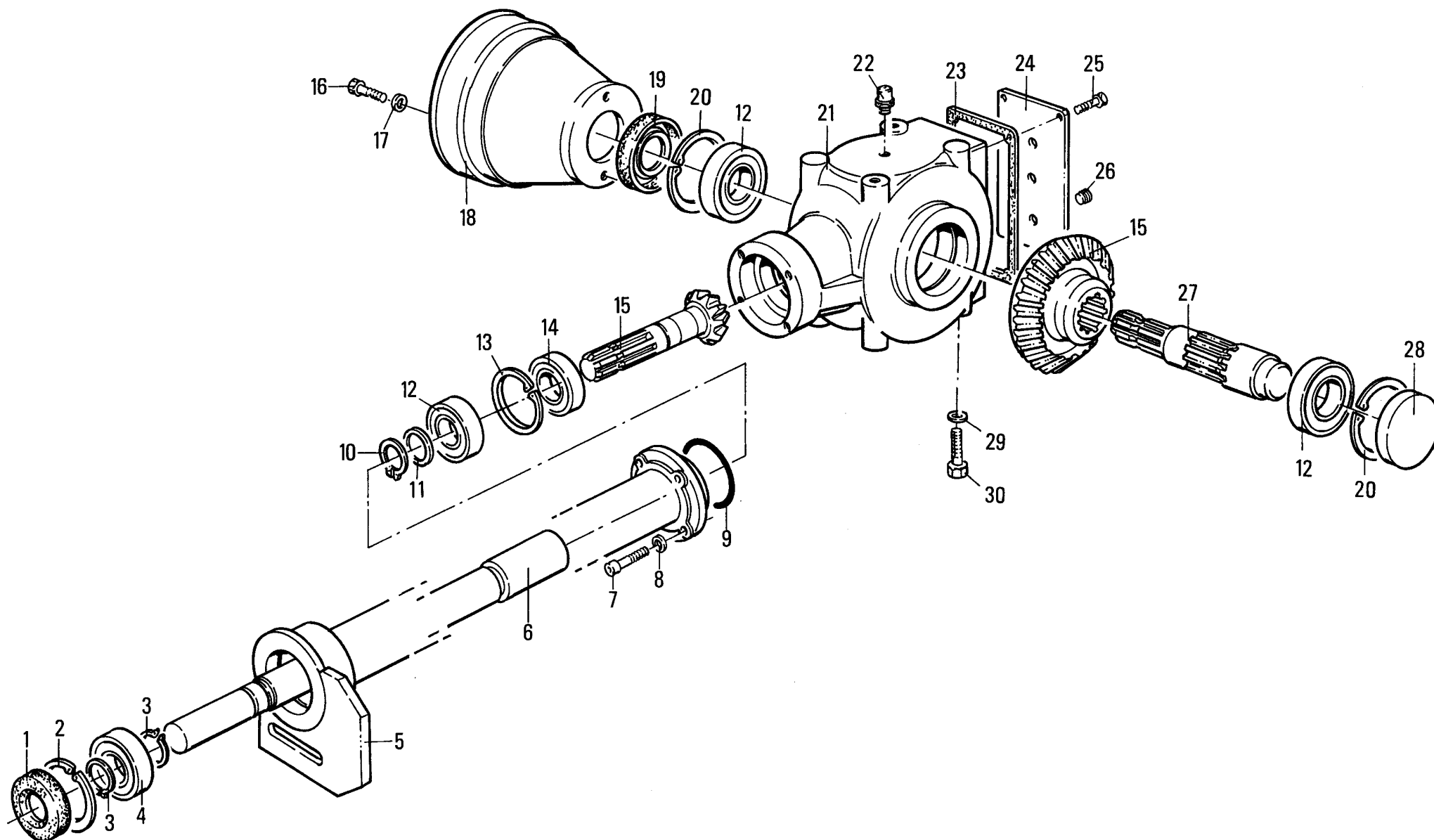

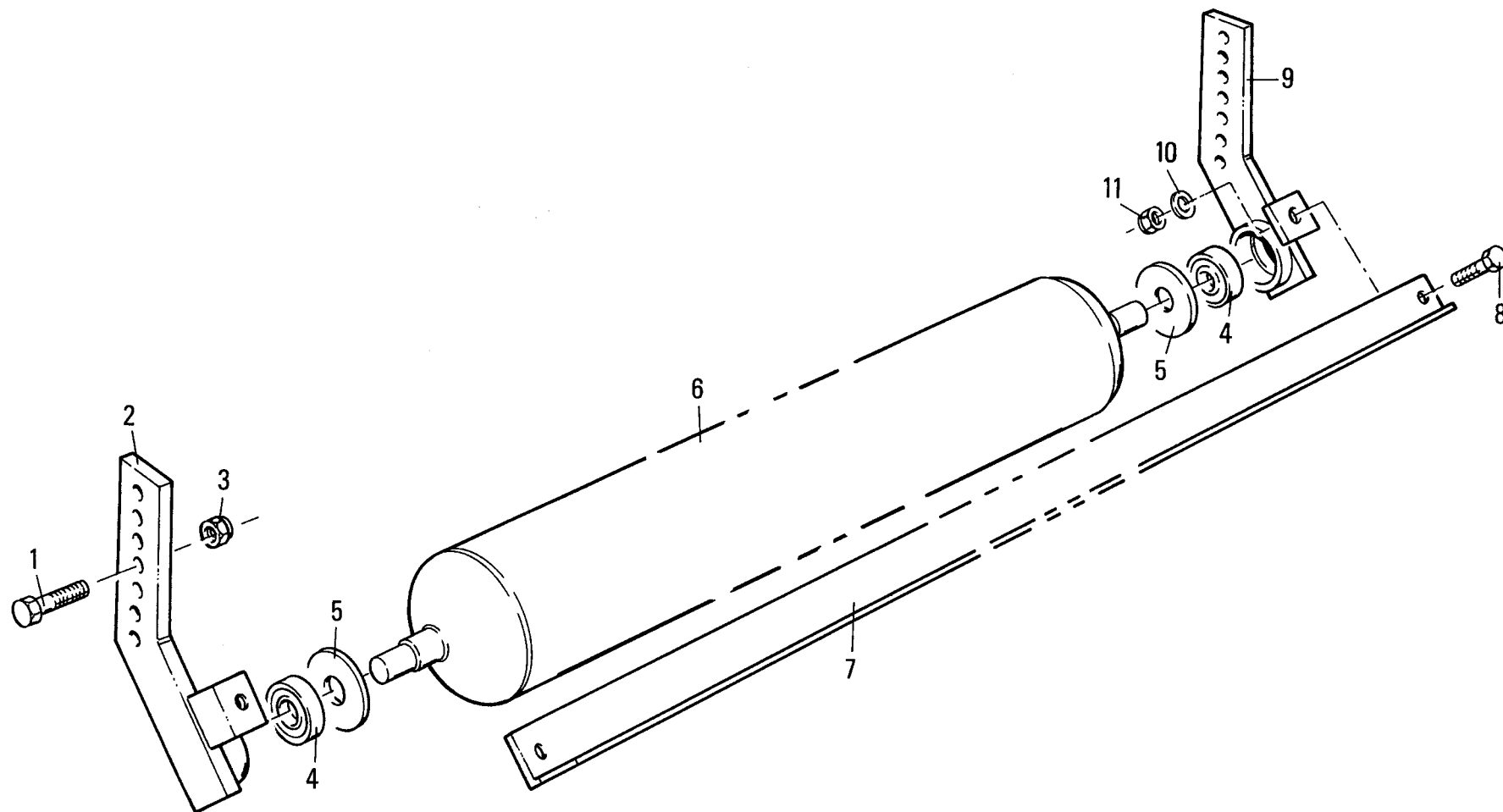

MURATORI MT 12

TAV. 5.0

POS.	N°	CODICE	Q	DESCRIZIONE	DESIGNATION	BENENNUNG	DESCRIPTION	DESIGNAZIONE	Da matr.	Fino matr
									De nr. serie	Jusqu'au nr. serie
									Vom Seriennr.	Bis Seriennr.
									From serial nr.	Up to serial nr.
1	60026400	4	VITE	VIS	SCHRAUBE	SCREW	TE 14 x 40 UNI 5739			
2	40144500	1	SUPPORTO SX	SUPPORT (G)	TRAEGER (LINKS)	SUPPORT (LH)				56265
2	40193100	1	SUPPORTO SX	SUPPORT (G)	TRAEGER (LINKS)	SUPPORT (LH)		56266		
3	62010800	4	DADO	ECROU	MUTTER	NUT	M 14 x 2 AUTOBLOCC.			
4	67008300	2	CUSCINETTO	ROULEMENT	LAGER	BEARING	6205 2RS			56265
4	67017500	2	CUSCINETTO	ROULEMENT	LAGER	BEARING	6305 2RS	56266		60723
4	67018100	2	CUSCINETTO	ROULEMENT	LAGER	BEARING	6305 2RS	60724		
5	39091200	2	DISCO	DISQUE	SCHEIBE	DISC	Øi 25 Øe 50			56265
5	39200500	2	DISCO	DISQUE	SCHEIBE	DISC		56266		
6	42050100	1	RULLO LIVELLATORE	ROULEAU ARRIERE	HINTERESTUETZWALZE	REAR ROLLER	100			
6	42050200	1	RULLO LIVELLATORE	ROULEAU ARRIERE	HINTERESTUETZWALZE	REAR ROLLER	115			
6	42050300	1	RULLO LIVELLATORE	ROULEAU ARRIERE	HINTERESTUETZWALZE	REAR ROLLER	130			
6	42050400	1	RULLO LIVELLATORE	ROULEAU ARRIERE	HINTERESTUETZWALZE	REAR ROLLER	160			
6	42050500	1	RULLO LIVELLATORE	ROULEAU ARRIERE	HINTERESTUETZWALZE	REAR ROLLER	190			
7	34014200	1	RASCHIARULLO	GRATTOIR	SCHABEISEN	SCRAPER	100			56265
7	34014300	1	RASCHIARULLO	GRATTOIR	SCHABEISEN	SCRAPER	115			56265
7	34014400	1	RASCHIARULLO	GRATTOIR	SCHABEISEN	SCRAPER	130			56265
7	34014500	1	RASCHIARULLO	GRATTOIR	SCHABEISEN	SCRAPER	160			56265
7	34014600	1	RASCHIARULLO	GRATTOIR	SCHABEISEN	SCRAPER	190			56265
7	34022400	1	RASCHIARULLO	GRATTOIR	SCHABEISEN	SCRAPER	100	56266		
7	34022500	1	RASCHIARULLO	GRATTOIR	SCHABEISEN	SCRAPER	115	56266		
7	34022600	1	RASCHIARULLO	GRATTOIR	SCHABEISEN	SCRAPER	130	56266		
7	34022700	1	RASCHIARULLO	GRATTOIR	SCHABEISEN	SCRAPER	160	56266		
7	34022800	1	RASCHIARULLO	GRATTOIR	SCHABEISEN	SCRAPER	190	56266		
8	60021300	2	VITE	VIS	SCHRAUBE	SCREW	TE 10 x 30 UNI 5739			
9	40144600	1	SUPPORTO DX	SUPPORT (D)	TRAEGER (RECHTS)	SUPPORT (RH)				56265

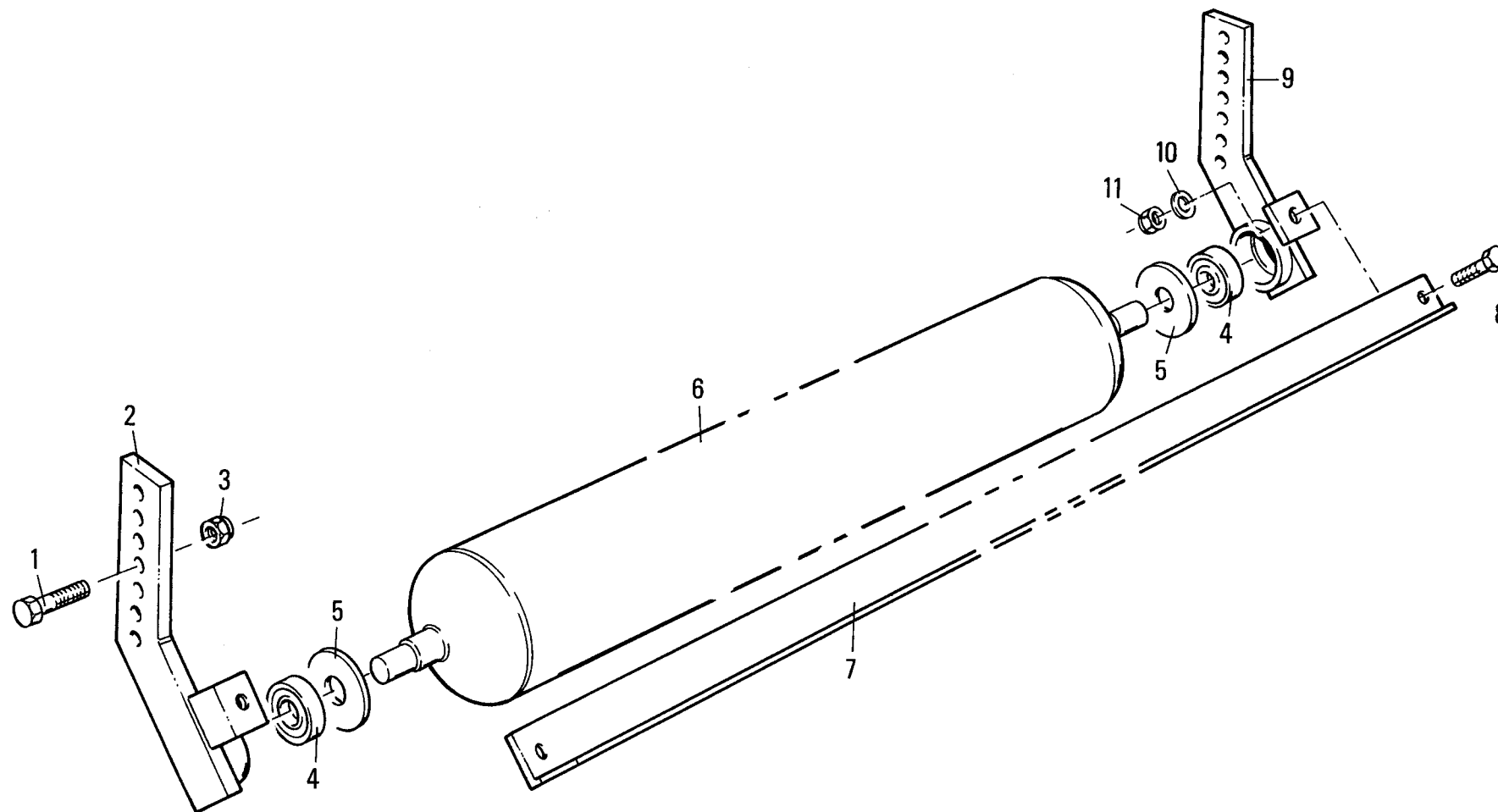

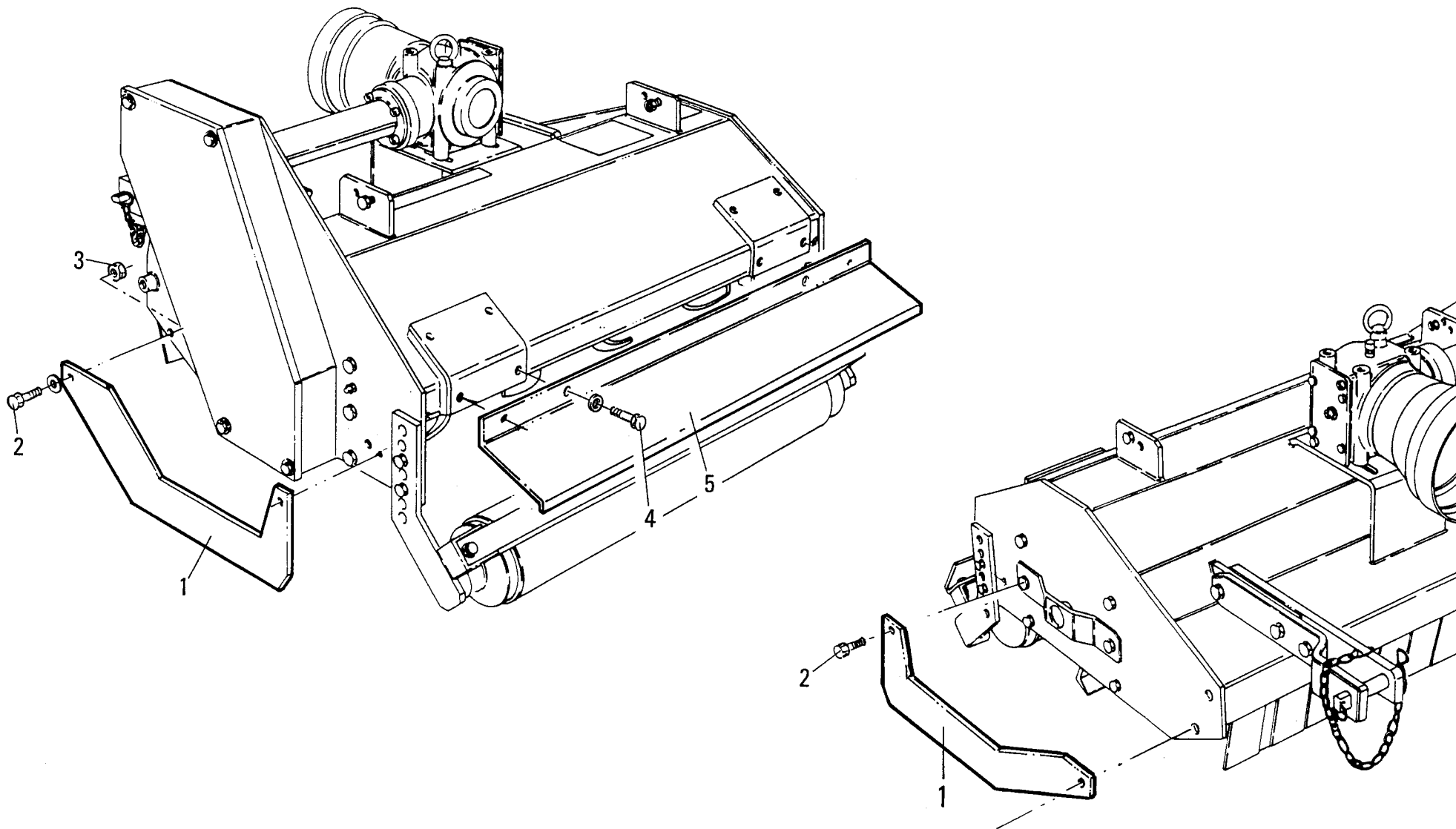

ZAPPATRICI - ERPICI ROTANTI - TRINCIATRICI

MURATORIM 

41051 CASTELNUOVO RANGONE (MODENA) Italy
Via Pavarello, 21 - 21/A-B-C -P.O.Box 45 -
Tel. ++39 059 535919 - Telefax ++39 059 537259
<http://www.muratoriequip.it>
e-mail: info@muratoriequip.it