



# MURATORI

**TIPO-TYPE-TYP  
MT20 ID**

**CATALOGO RICAMBI  
Catalogue Pièces Detachées  
Ersatzteilkatalog  
Spare Parts Catalogue  
Catálogo Recambios**

**EDIZIONE 10/2015**



Per ordinare parti di ricambio specificare:

- tipo e matricola della macchina (apposti sulla macchina o sui documenti di acquisto);
- numero del riferimento del pezzo nel disegno (Pos.), numero della tavola (Tav.) e numero di codice

**N.B.:** le indicazioni destro o sinistro vengono date guardando la macchina da dietro.

*Pour les commandes de pièces de rechange veuillez spécifier:*

- *type et numéro de série de la machine (indiqués sur la machine et sur le bon d'achat);*
- *numéro de référence du pièce sur le plan (Pos.), numéro du plan (Tav.) et numéro de code (codice)*

**N.B.:** *les indications droite ou gauche sont données en regardant la machine par derrière.*

*Zum Bestellen von Ersatzteilen folgendes angeben:*

- *Typ und Serien-Nr. der Maschine (zu finden auf der Maschine oder der Einkaufspapieren);*
- *Bezug-Nr. des Ersatzteils auf der Zeichnung (Pos.), Zeichnungsnummer (Tav.) und Kodenummer (codice)*

**N.B.:** *die Angaben rechts und links verstehen sich so, dass man hinter der Maschine steht.*

When ordering spare parts specify:

- machine type and serial number (found on the machine or on the purchasing documents);
- reference number of the part on the relative drawing (Pos.) number of the drawing (Tav.) and part number (codice)

**N.B.:** right-hand or left-hand indications are made by viewing the machine from the rear.

**TAV. 1.0**

GRUPPO TELAIO  
 ENSEMBLE CHASSIS  
 SATZ FÜR RAHMEN  
 KIT FOR FRAME

**TAV. 2.0**

GRUPPO TRASMISSIONE ROTORE  
 ENSEMBLE TRANSMISSION ROTORS  
 SATZ FÜR DEN ROTARONTRIEB  
 KIT FOR THE ROTOR TRANSMISSION

**TAV. 3.0**

GRUPPO RULLO POSTERIORE  
 ENSEMBLE ROULEAU ARRIERE  
 SATZ HINTERE WALZE  
 KIT REAR ROLLER

**TAV. 4.0**

GRUPPO MOTORE IDRAULICO  
 GROUPE MOTEUR HYDRAULIQUE  
 HYDRAULIKMOTORGRUPPE  
 HYDRAULIC MOTOR GROUP

**TAV. 5.0**

IMPIANTO IDRAULICO  
 INSTALLATION HYDRAULIQUE  
 HYDRAULISCHEANLAGE  
 HYDRAULIC SYSTEM

**TAV. 6.0**

ATTACCO FRONTALE  
 ATTELAGE FRONTAL  
 FRONTANBAU  
 FRONT LINKAGE

**TAV. 7.0**

ACCESSORI A COMPLETAMENTO  
 OPTIONS D'ACHEVEMENT  
 ZUBEHÖRE ZUR ERGANZUNG DER MASCHINE  
 CHOICE OF EQUIPMENT COMPLETING MACHINE

**TAV. 8.0**

PROTEZIONE VALVOLA  
 TÔLE DE PROTECTION  
 SCHUTZ  
 PROTECTION

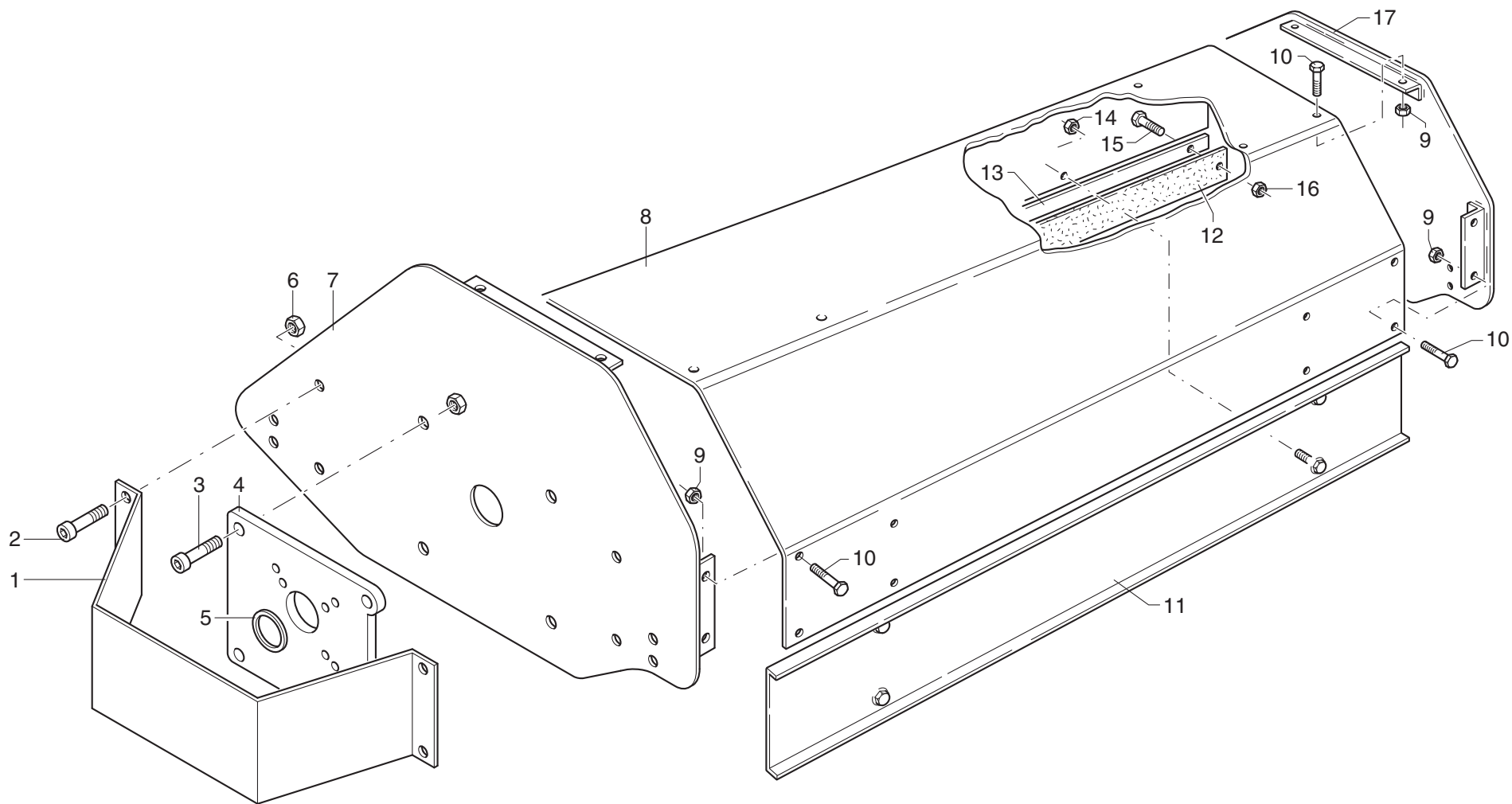

# MURATORI MT20 ID

TAV. 1.0

POS.	N° CODICE	Q.	DESCRIZIONE	DESIGNATION	BENENNUNG	DESCRIPTION	DESIGNAZIONE	Da matr. De nr. serie Vom Seriennr. From serial nr.	Fino matr. Jusqu'au nr. serie Bis Seriennr. Up to serial nr.
1	39287400	1	PROTEZIONE	PROTECTION	SCHUTZ	GUARD			
2	60020400	4	VITE	VIS	SCHRAUBE	SCREW	TE 12x25 UNI 5739		
3	60032800	4	VITE	VIS	SCHRAUBE	SCREW	TCEI 8x30 UNI 5931 - 105-130		
3	60043100	4	VITE	VIS	SCHRAUBE	SCREW	TCEI 10x30 UNI 5931 -155		
4	39287200	1	FLANGIA	BRIDE	FLANSCH	FLANGE			
5	32185200	1	ANELLO	BAGUE	RING	RING	105-130		
6	62010600	4	DADO	ECROU	MUTTER	NUT	M 12x1,75 AUTOBLOCC.		
7	40273200	1	FIANCO	FLANC	SEITENWAND	SIDE FRAME			
8	39251900	1	TELAIO	CHASSIS	RAHMEN	FRAME	105		
8	39252000	1	TELAIO	CHASSIS	RAHMEN	FRAME	130		
8	39252100	1	TELAIO	CHASSIS	RAHMEN	FRAME	155		
9	62010400	16	DADO	ECROU	MUTTER	NUT	M 10x1,5 AUTOBLOCC.		
10	60002300	16	VITE	VIS	SCHRAUBE	SCREW	TE 10x25 UNI 5739		
11	40231400	1	RINFORZO	RENFORT	VERSTÄRKUNG	REINFORCEMENT	105		
11	40231500	1	RINFORZO	RENFORT	VERSTÄRKUNG	REINFORCEMENT	130		
11	40231600	1	RINFORZO	RENFORT	VERSTÄRKUNG	REINFORCEMENT	155		
12	68067800	1	BANDELLA	BANDE	BAND	STRAP	105		
12	68067900	1	BANDELLA	BANDE	BAND	STRAP	130		
12	68068000	1	BANDELLA	BANDE	BAND	STRAP	155		
13	30125500	1	PIATTO	PLAQUE	PLATTE	DISC	105		
13	30125600	1	PIATTO	PLAQUE	PLATTE	DISC	130		
13	30125700	1	PIATTO	PLAQUE	PLATTE	DISC	155		
14	62010600	4	DADO	ECROU	MUTTER	NUT	M 12x1,75 AUTOBLOCC.		
15	60022800		VITE	VIS	SCHRAUBE	SCREW	TE 8x20 UNI 5739		
16	62010200		DADO	ECROU	MUTTER	NUT	M 8x1,25 AUTOBLOCC.		
17	40227600	1	FIANCO	FLANC	SEITENWAND	SIDE FRAME			

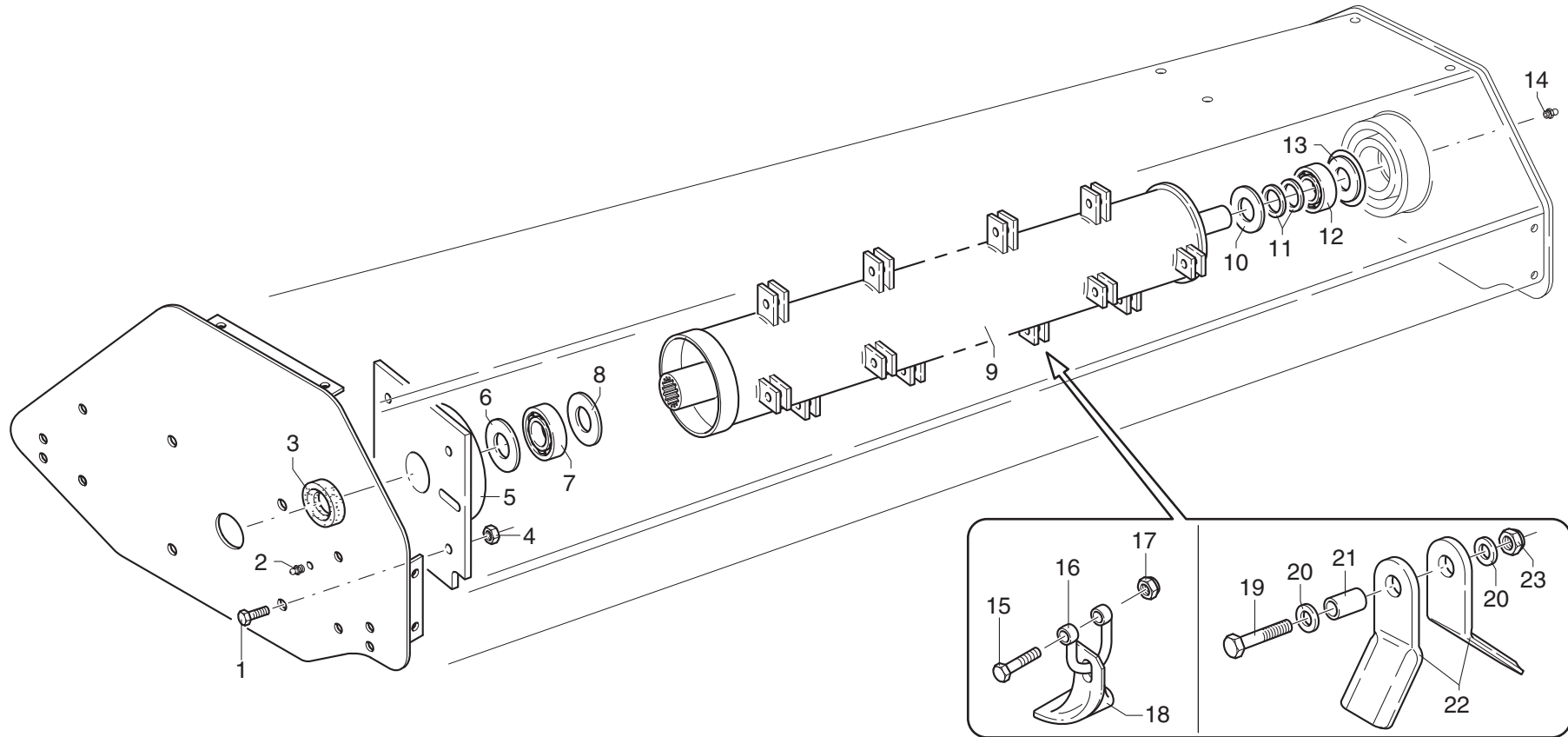

# MURATORI MT20 ID

TAV. 2.0

POS.	N° CODICE	Q.	DESCRIZIONE	DESIGNATION	BENENNUNG	DESCRIPTION	DESIGNAZIONE	Da matr. De nr. serie Vom Seriennr. From serial nr.	Fino matr. Jusqu'au nr. serie Bis Seriennr. Up to serial nr.
1	60026400	4	VITE	VIS	SCHRAUBE	SCREW	TE 14 x 40 UNI 5737		
2	64001800	1	INGRASSATORE	GRAISSEUR	SCHMIERNIPPEL	GREASE FITTING	M 10 x 1		
3	66014100	1	ANELLO TENUTA	JOINT D'ETANCHEITE	DICHTUNGSRING	JUNT RING	45 x 55 x 6		
4	62010800	4	DADO	ECROU	MUTTER	NUT	M 14 x 2 AUTOBLOCC.		
5	40218600	1	SUPPORTO	SUPPORT	HALTERUNG	SUPPORT			
6	68011000	1	SPESSORE	EPAISSEUR	DISTANZRING	SPACER	55 x 45 x 1		
7	67018200	1	CUSCINETTO	ROULEMENT	LAGER	BEARING	2209		
8	39237400	1	PROTEZIONE	PROTECTION	SCHUTZ	GUARD			
9	42074200	1	ROTORE	ROTOR	ROTOR	ROTOR	105		116611
9	42079600	1	ROTORE	ROTOR	ROTOR	ROTOR	105	116612	
9	42074300	1	ROTORE	ROTOR	ROTOR	ROTOR	130		116611
9	42079700	1	ROTORE	ROTOR	ROTOR	ROTOR	130	116612	
9	42074400	1	ROTORE	ROTOR	ROTOR	ROTOR	155		
10	39091100	1	PROTEZIONE	PROTECTION	SCHUTZ	GUARD			
11	68068800	1	SPESSORE	EPAISSEUR	DISTANZRING	SPACER	42 x 30 x 1		
12	67012900	1	CUSCINETTO	ROULEMENT	LAGER	BEARING	1306		
13	32171000	1	SPESSORE	EPAISSEUR	DISTANZRING	SPACER			
14	64000200	1	INGRASSATORE	GRAISSEUR	SCHMIERNIPPEL	GREASE FITTING	M 6 x 1		
15	60007700		VITE	VIS	SCHRAUBE	SCREW	TE 14 x 70 UNI 5737		
16	68074000		CAVALLOTTO	ARRETOIR	KLEMMSTÜCK	UBOLT			
17	62010800		DADO	ECROU	MUTTER	NUT	M 14 x 2 AUTOBLOCC.		
18	12015100		COLTELLO	COUPEAU	MESSER	KNIFE			
19	60012900		VITE	VIS	SCHRAUBE	SCREW	TE 8 x 45 UNI 5737		
20	61006200		RONDELLA	RONDELLE	SCHEIBE	WASHER	PIANA Ø 9		
21	31042800		BOCCOLA	DOUILLE	BUCHSE	BUSHING			
22	12010200		COLTELLO	COUPEAU	MESSER	KNIFE			

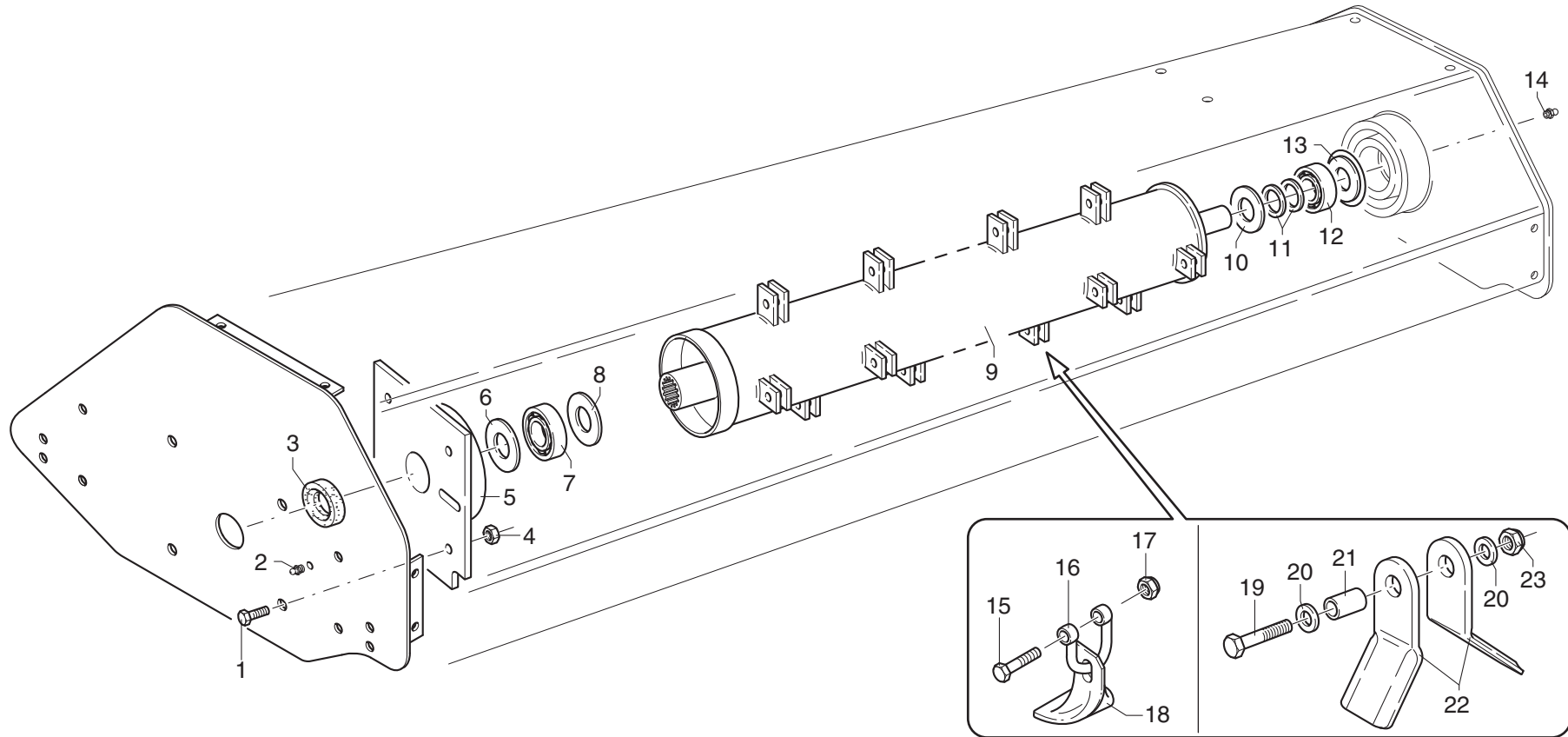



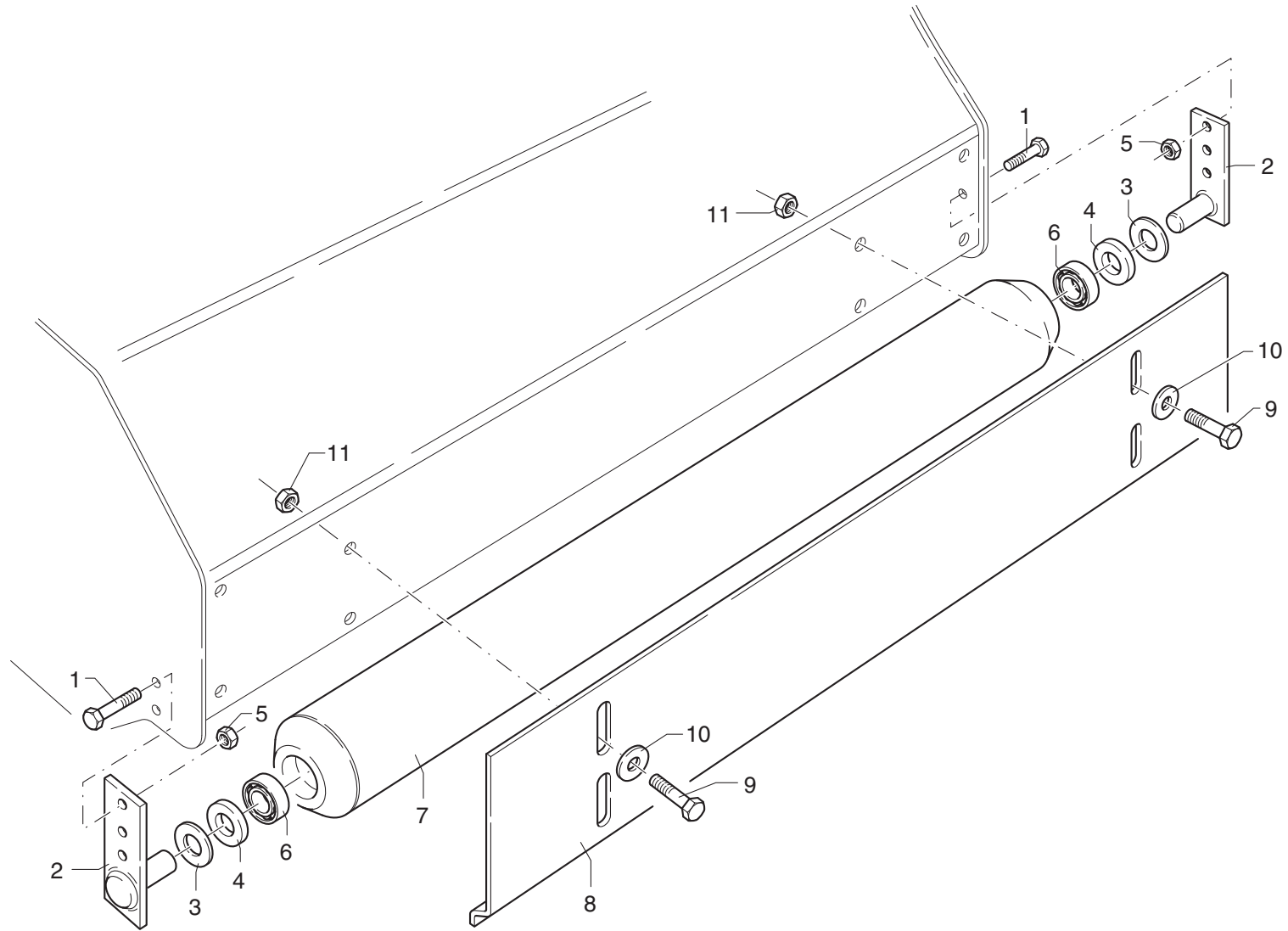



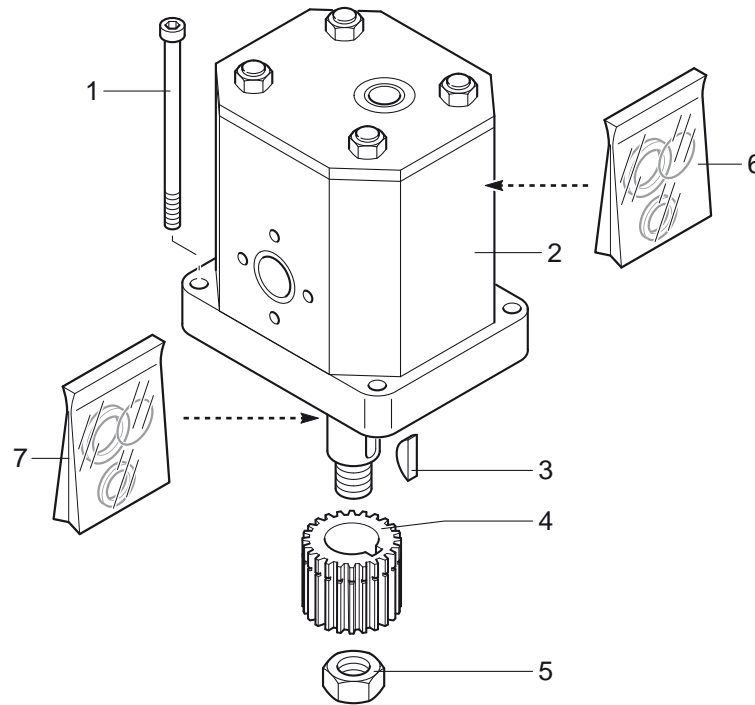



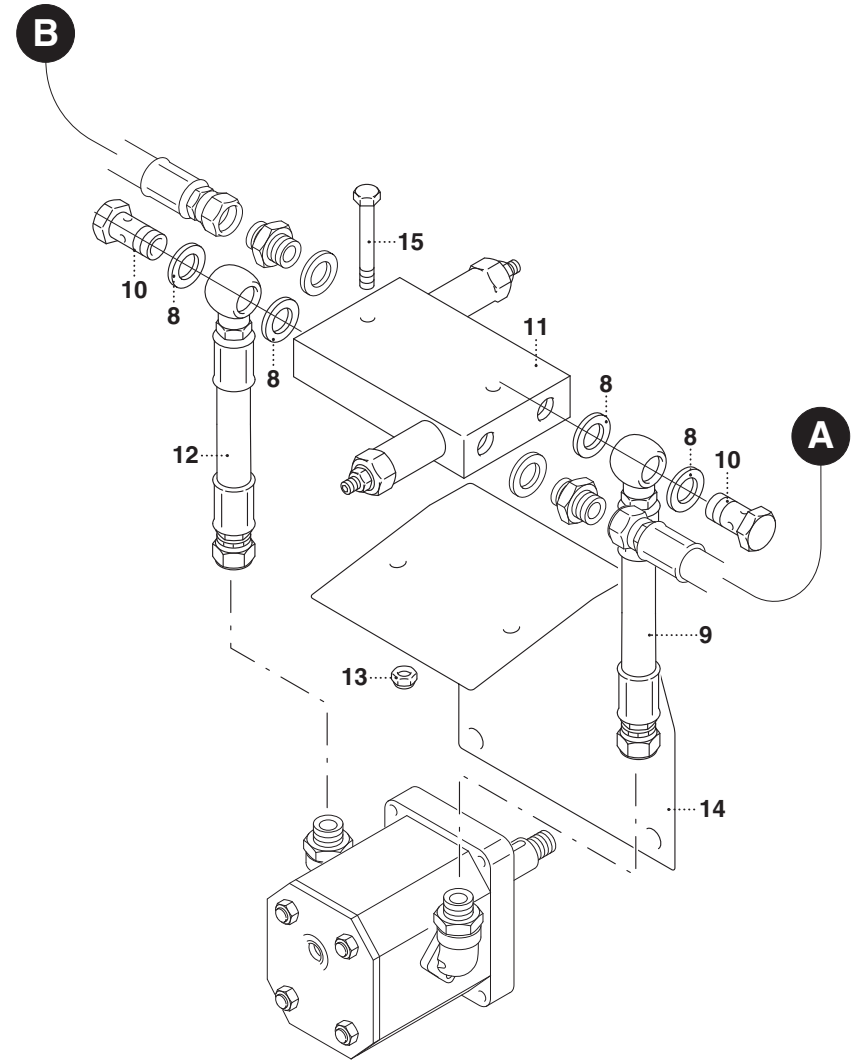
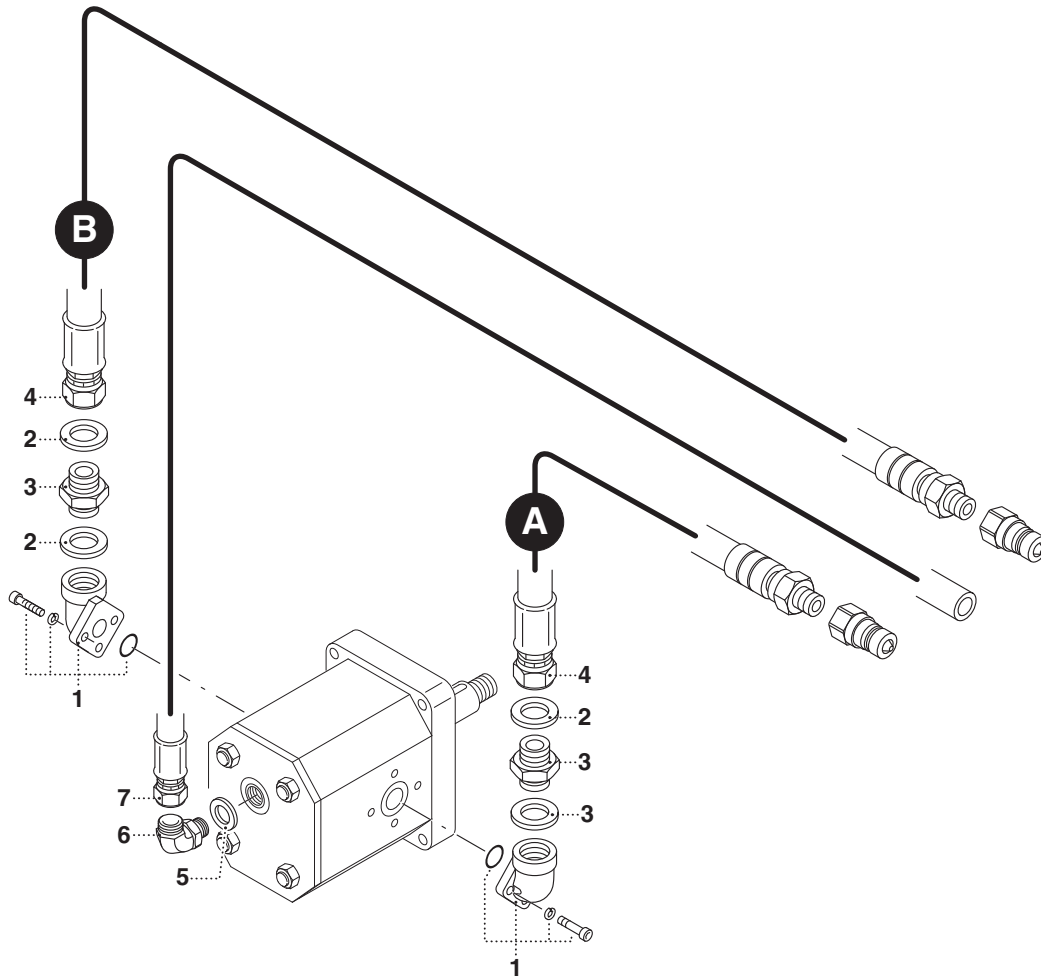



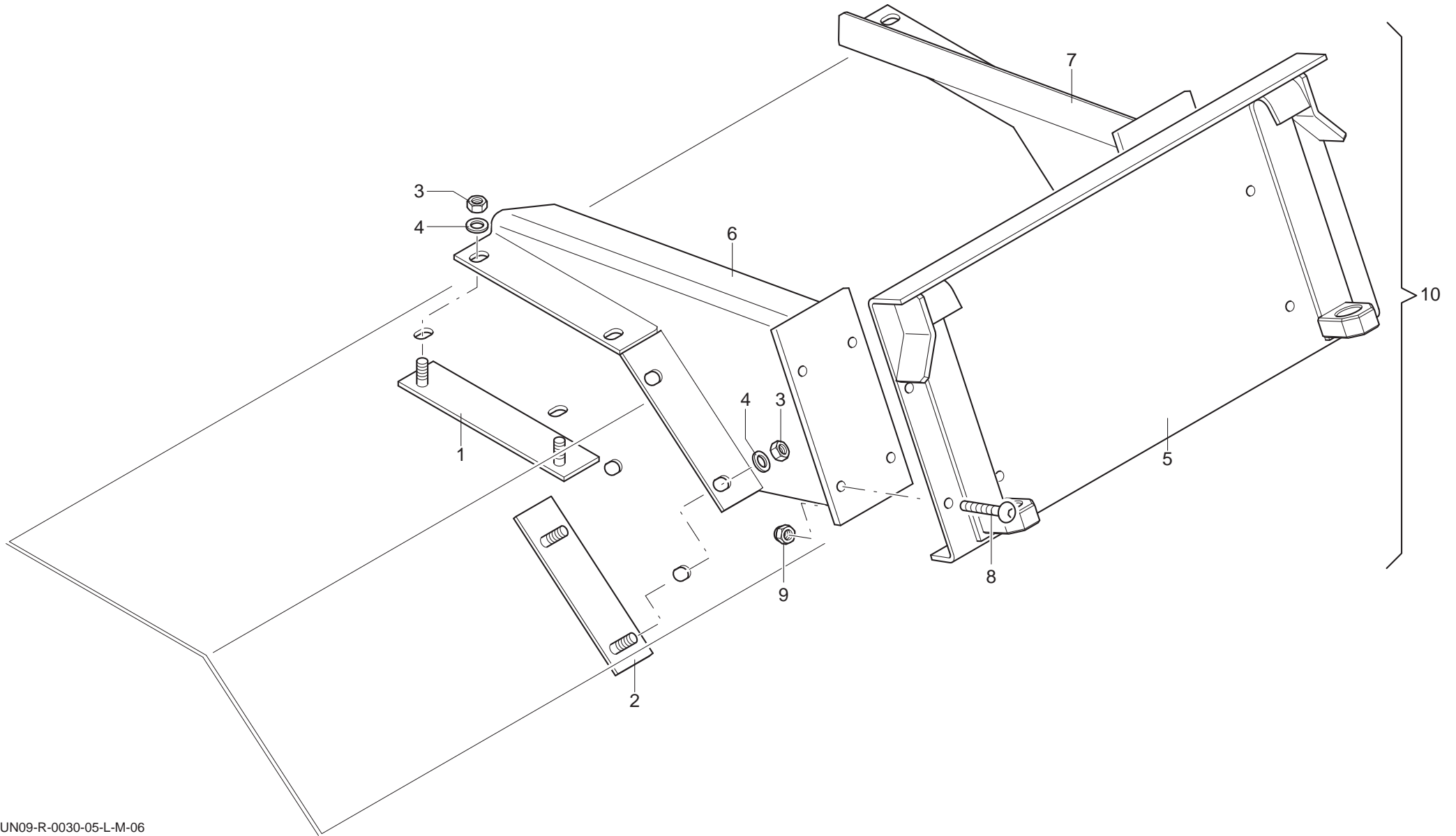



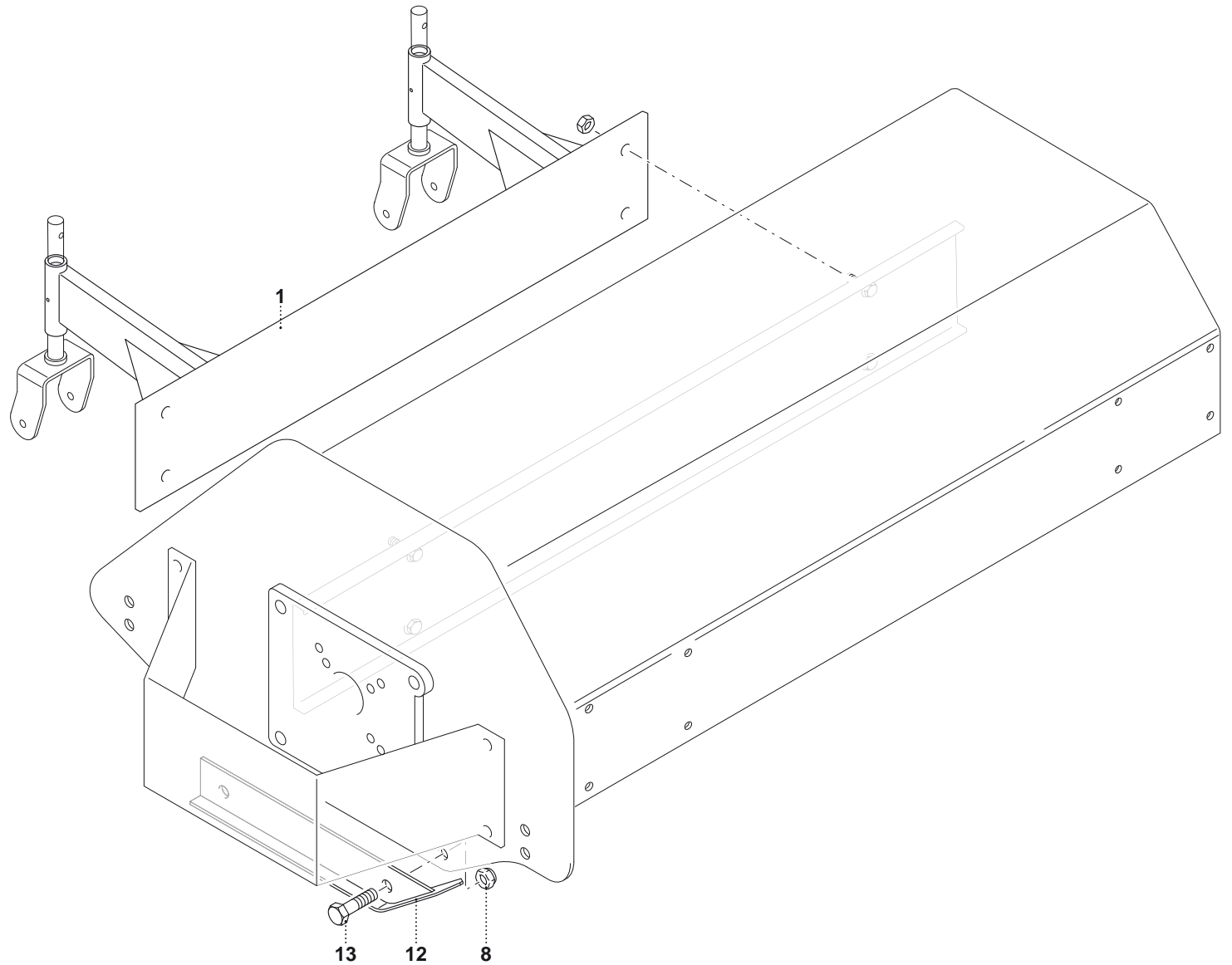
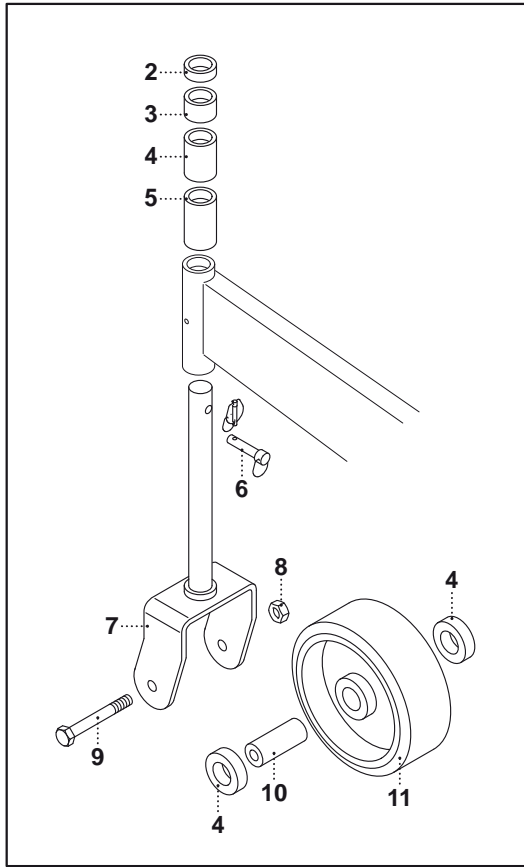



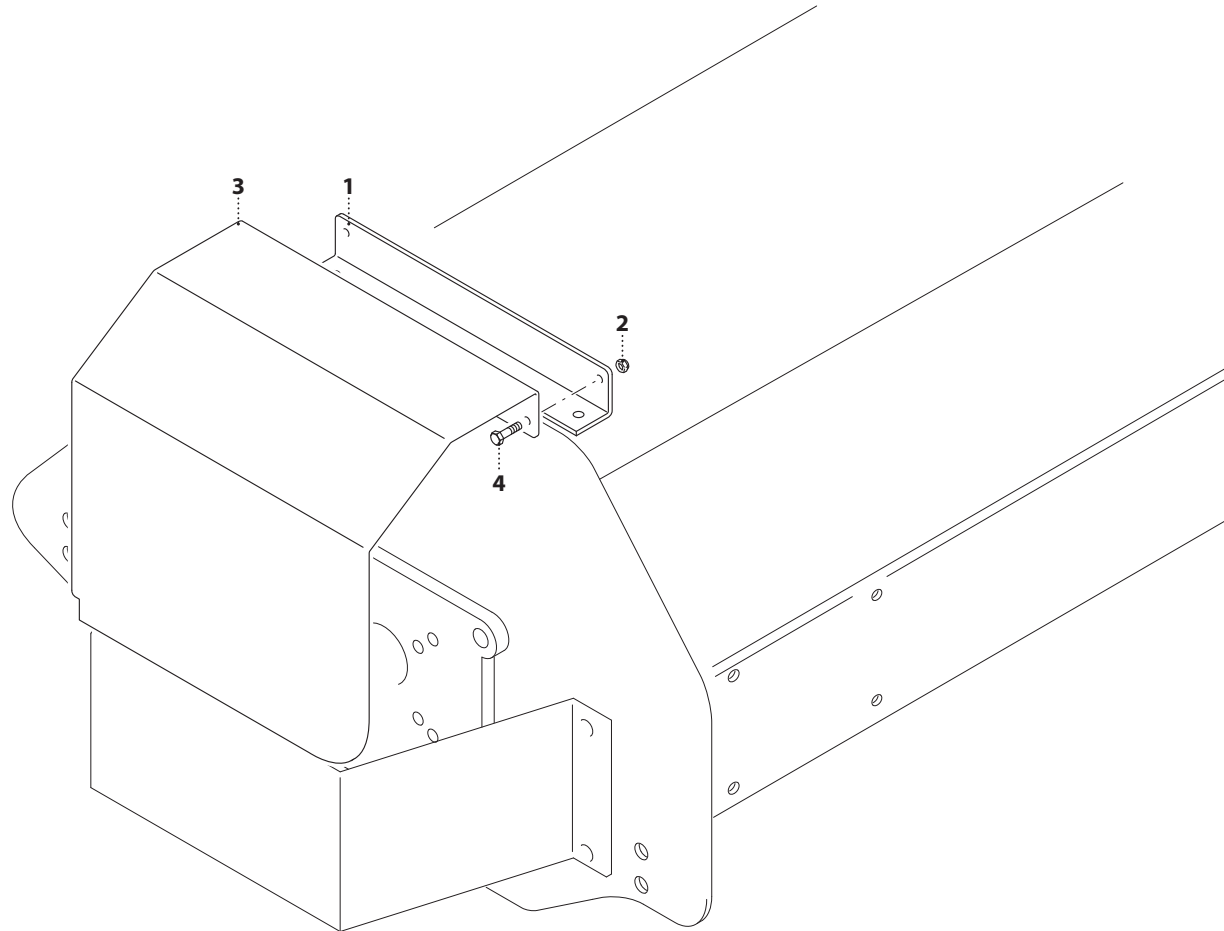









**MURATORI S.p.A.**

Via Pavarello, 21 - 41051 Castelnuovo Rangone (MO) Italy - Tel. 059.5330611 Fax 059.537259

**[www.muratoriequip.it](http://www.muratoriequip.it)** *info@muratoriequip.it*

**Capitale sociale Euro 480.000 interamente versato**

**Registro Imprese di Modena**

**Codice fiscale e numero d'iscrizione: 00708860366**