



MURATORI

**TIPO-TYPE-TYP
MT 23**

CATALOGO RICAMBI
Catalogue Pièces Detachées
Ersatzteilkatalog
Spare Parts Catalogue
Catálogo Recambios

EDIZIONE 10/2015

Per ordinare parti di ricambio specificare:

- tipo e matricola della macchina (apposti sulla macchina o sui documenti di acquisto);
- numero del riferimento del pezzo nel disegno (Pos.), numero della tavola (Tav.) e numero di codice

N.B.: le indicazioni destro o sinistro vengono date guardando la macchina da dietro.

Pour les commandes de pièces de rechange veuillez spécifier:

- *type et numéro de série de la machine (indiqués sur la machine et sur le bon d'achat);*
- *numéro de référence du pièce sur le plan (Pos.), numéro du plan (Tav.) et numéro de code (codice)*

N.B.: *les indications droite ou gauche sont données en regardant la machine par derrière.*

Zum Bestellen von Ersatzteilen folgendes angeben:

- *Typ und Serien-Nr. der Maschine (zu finden auf der Maschine oder der Einkaufspapieren);*
- *Bezug-Nr. des Ersatzteils auf der Zeichnung (Pos.), Zeichnungsnummer (Tav.) und Kodenummer (codice)*

N.B.: *Die Angaben rechts und links verstehen sich so, dass man hinter der Maschine steht.*

When ordering spare parts specify:

- machine type and serial number (found on the machine or on the purchasing documents);
- reference number of the part on the relative drawing (Pos.) number of the drawing (Tav.) and part number (codice)

N.B.: right-hand or left-hand indications are made by viewing the machine from the rear.

TAV. 1.0

GRUPPO TELAIO
 ENSEMBLE CHASSIS
 SATZ FÜR RAHMEN
 KIT FOR FRAME

TAV. 2.0

ATTACCO STANDARD
 ATTELAGE STANDARD
 STANDARDANSCHLUSS
 STANDARD HITCH

TAV. 3.0

ATTACCO FRONTALE STANDARD
 ATTELAGE FRONTAL STANDARD
 VERSTELLBARER FRONTANSCHLUSS
 STANDARD FRONT HITCH

TAV. 4.0

ATTACCO SCORREVOLE
 ATTELAGE DEPLAÇABLE
 VERSCHIEBBARER ANSCHLUSS
 SIDE SHIFTING HITCH

TAV. 5.0

ATTACCO FRONTALE SCORREVOLE
 ATTELAGE FRONTAL DEPLAÇABLE
 VERSCHIEBBARER FRONTANSCHLUSS
 SLIDING FRONT HITCH

TAV. 6.0

GRUPPO RULLO ROTORE
 ENSEMBLE ROTOR
 SATZ FÜR ROTOR
 KIT FOR ROTOR

TAV. 7.0

GRUPPO MOLTIPLICATORE
 ENSEMBLE MULTIPLICATEUR
 SATZ FÜR GETRIEBE
 KIT FOR GEAR BOX

TAV. 8.0

GRUPPO RULLO POSTERIORE
 ENSEMBLE ROULEAU ARRIERE
 SATZ HINTERE WALZE
 KIT REAR ROLLER

TAV. 9.0 1/2

ACCESSORI A COMPLETAMENTO
 OPTIONS D'ACHEVEMENT
 ZUBEHÖRE ZUR MASCHINENERGÄNZUNG
 COMPLETING MACHINE EQUIPMENT

TAV. 9.0 2/2

ACCESSORI A COMPLETAMENTO
 OPTIONS D'ACHEVEMENT
 ZUBEHÖRE ZUR MASCHINENERGÄNZUNG
 COMPLETING MACHINE EQUIPMENT

TAV. 10.0

ALBERO CARDANICO COMPLETO (130-140)
 ARBRE A JOINTS DE CARDAN (130-140)
 KARDANWELLE (130-140)
 PTO SHAFT (130-140)

TAV. 11.0

ALBERO CARDANICO COMPLETO (160-220)
 ARBRE A JOINTS DE CARDAN (160-220)
 KARDANWELLE (160-220)
 PTO SHAFT (160-220)

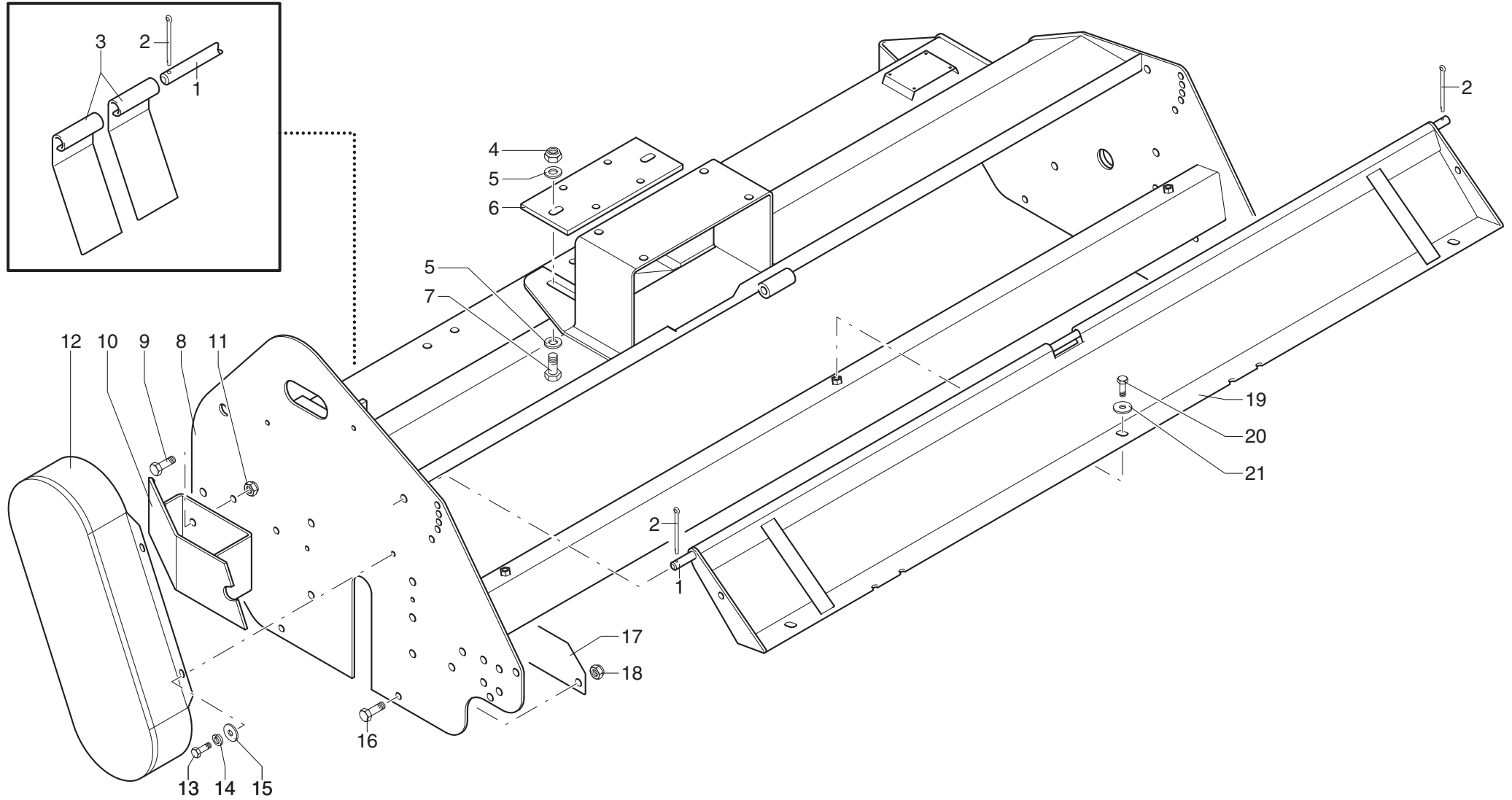

MURATORI MT 23

TAV. 1.0

POS.	N° CODICE	Q.	DESCRIZIONE	DESIGNATION	BENENNUNG	DESCRIPTION	DESIGNAZIONE	Da matr. De nr. serie Vom Seriennr. From serial nr.	Fino matr. Jusqu'au nr. serie Bis Seriennr. Up to serial nr.
1	31049601	2	ASTA	TIGE	STANGE	ROD	130		
1	31074200	2	ASTA	TIGE	STANGE	ROD	140		
1	31049701	2	ASTA	TIGE	STANGE	ROD	160		
1	31049801	2	ASTA	TIGE	STANGE	ROD	190		
1	31074300	2	ASTA	TIGE	STANGE	ROD	220		
2	64003700	4	COPIGLIA	COUPILLE	SPLINT	COTTER PIN	3x40		
3	39128400		BANDELLA	BANDE	BAND	STRAP	L=70		
3	39164300		BANDELLA	BANDE	BAND	STRAP	L=45		
3	39164200		BANDELLA	BANDE	BAND	STRAP	L=35		
3	39164100		BANDELLA	BANDE	BAND	STRAP	L=25		
4	62010800	2	DADO	ECROU	MUTTER	NUT	M 14x2 AUTOBLOCC.		
5	61006600	4	RONDELLA	RONDELLE	SCHEIBE	WASHER	PIANA Ø 14 UNI 6592		
6	30163100	1	PIASTRA	PLAQUE	PLATTE	PLATE			
7	60026400	2	VITE	VIS	SCHRAUBE	SCREW	TE 14x40 UNI 5739		
8	41118300	1	TELAIO	CHASSIS	RAHMEN	FRAME	130		
8	41118400	1	TELAIO	CHASSIS	RAHMEN	FRAME	140		
8	41118500	1	TELAIO	CHASSIS	RAHMEN	FRAME	160		
8	41118600	1	TELAIO	CHASSIS	RAHMEN	FRAME	190		
8	41118700	1	TELAIO	CHASSIS	RAHMEN	FRAME	220		
9	60023000	3	VITE	VIS	SCHRAUBE	SCREW	TE 12x30 UNI 5739 8.8 ZNT		
10	40280600	1	PARAURTI	PARE-CHOCS	STOSS-STANGE	BUMPER			
11	62010600	3	DADO	ECROU	MUTTER	NUT	M 12x1,75 AUTOBLOCC.		
12	40219001	1	CARTER	CARTER	KETTENKASTEN	CASING			
13	60024600	4	VITE	VIS	SCHRAUBE	SCREW	TE 8x12 UNI 5739		
14	61002500	4	RONDELLA	RONDELLE	SCHEIBE	WASHER	GROWER Ø 8 UNI 1751		
15	61006200	4	RONDELLA	RONDELLE	SCHEIBE	WASHER	PIANA Øi 9 Øe 24		

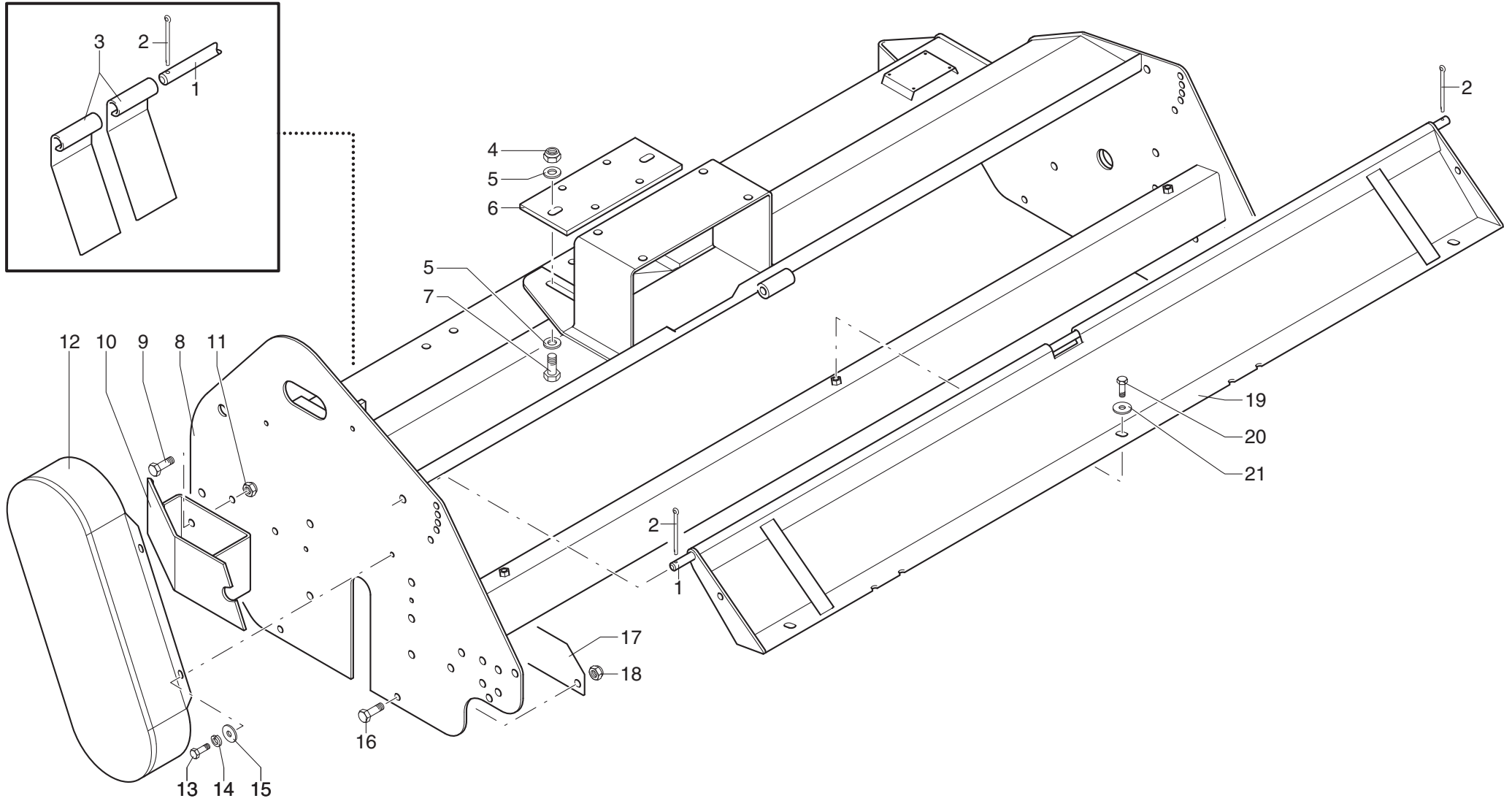

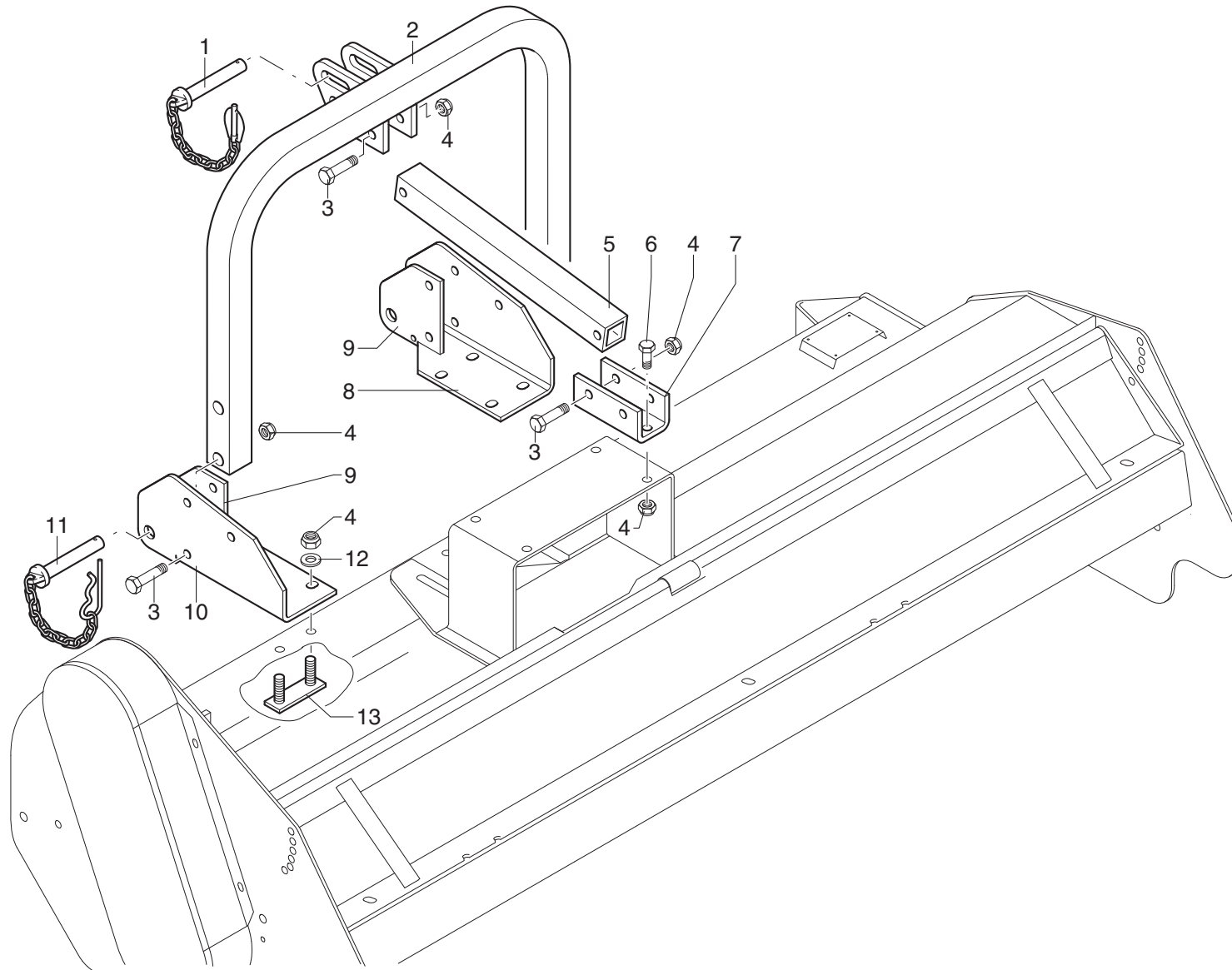

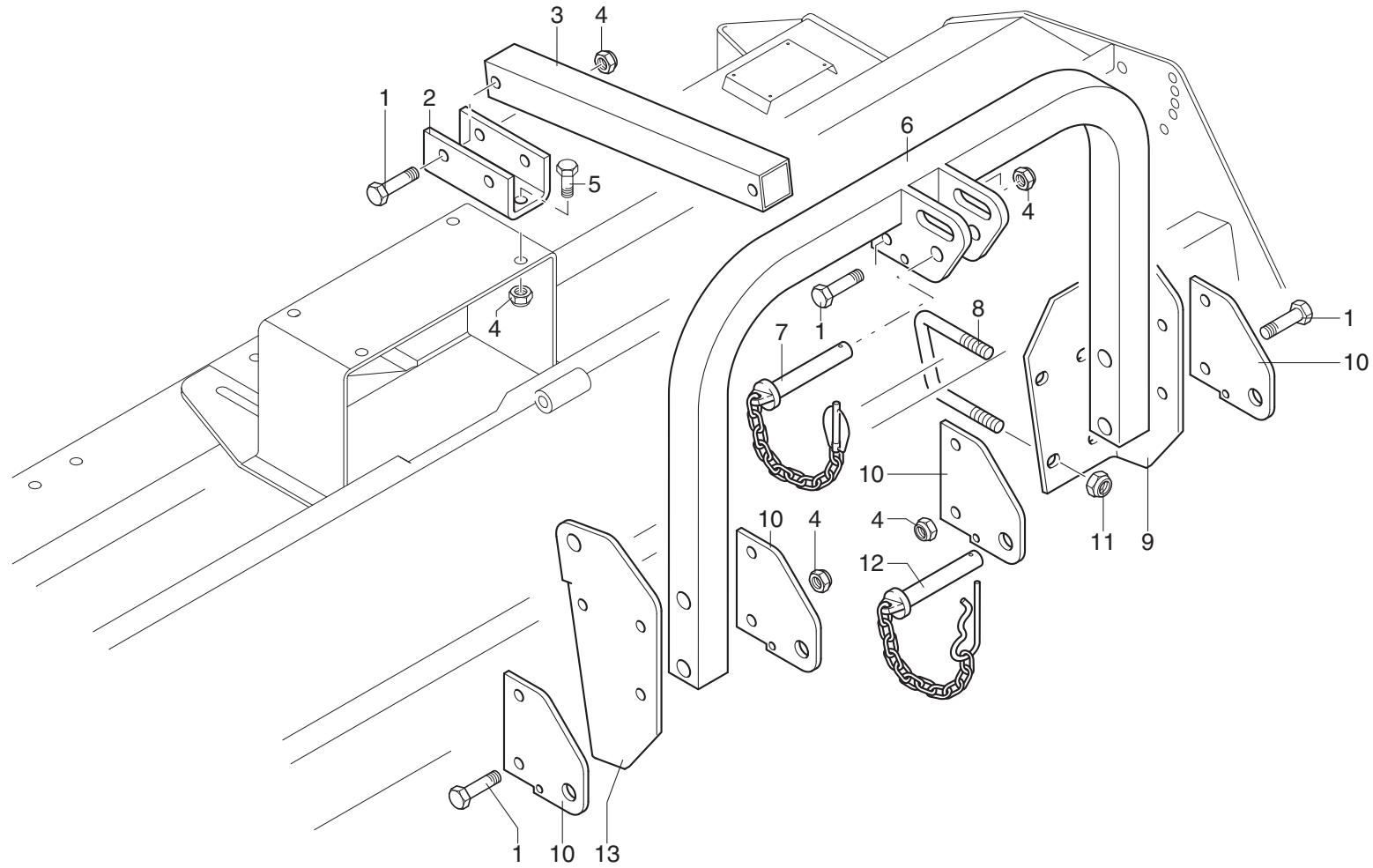

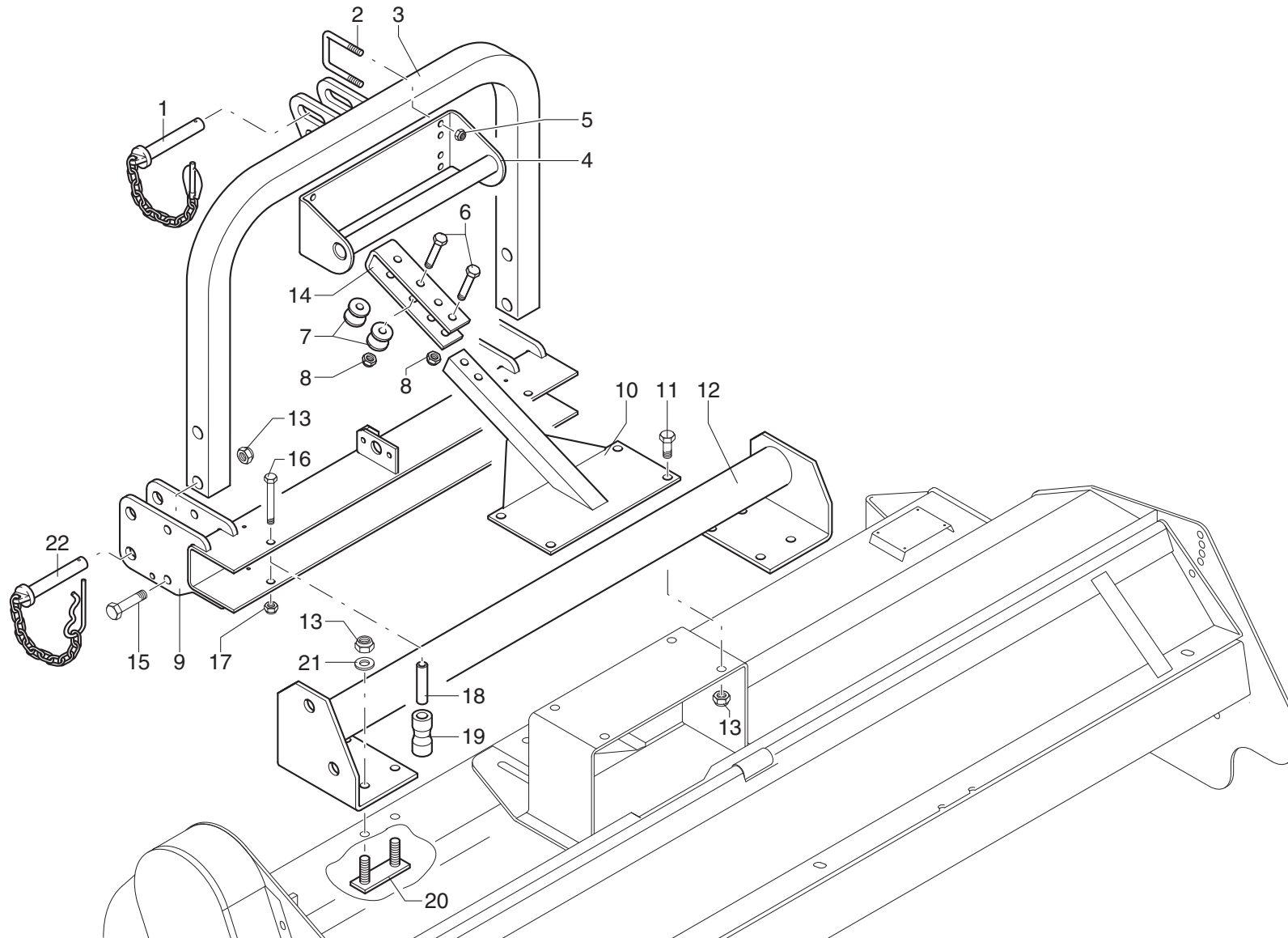

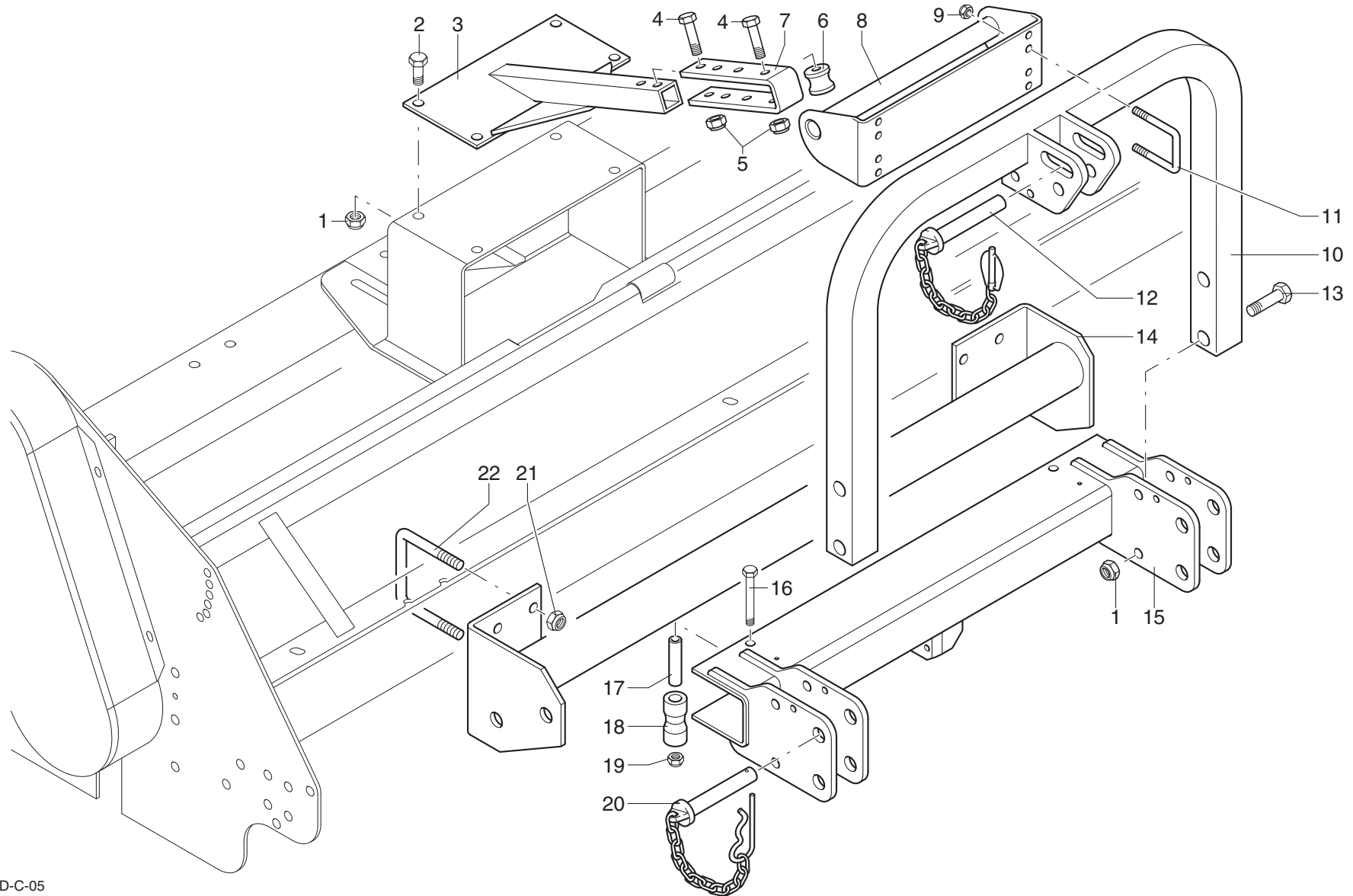

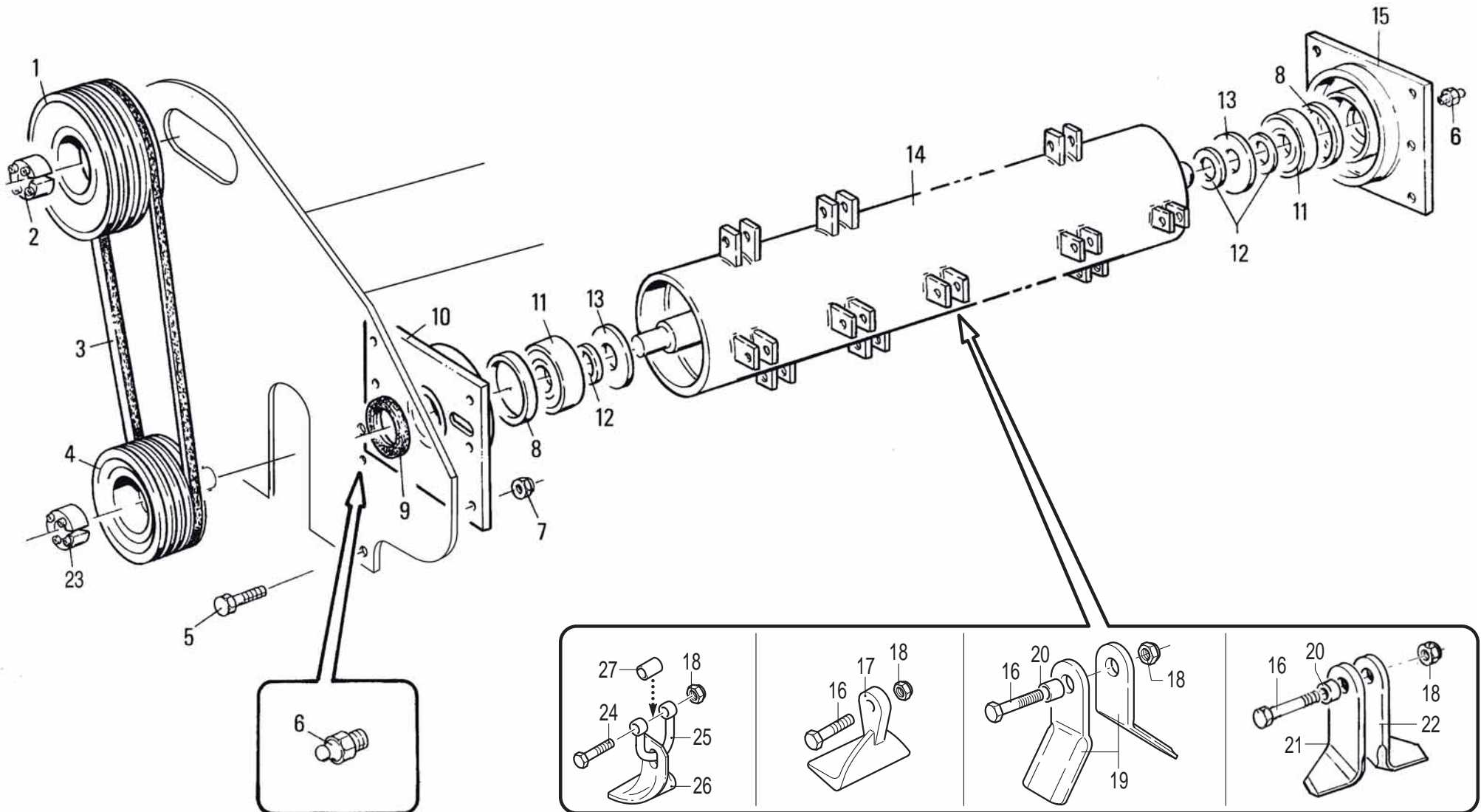

MURATORI MT 23

TAV. 6.0

POS.	N° CODICE	Q.	DESCRIZIONE	DESIGNATION	BENENNUNG	DESCRIPTION	DESIGNAZIONE	Da matr. De nr. serie Vom Seriennr. From serial nr.	Fino matr. Jusqu'au nr. serie Bis Seriennr. Up to serial nr.
1	68059300	1	PULEGGIA	POULIE	RIEMENSCHLEIBE	PULLEY	Øe 160 Øi 65 2 SPB (130-140)		123849
1	68059600	1	PULEGGIA	POULIE	RIEMENSCHLEIBE	PULLEY	Øe 160 Øi 65 3 SPB (160-190)		123849
1	68060500	1	PULEGGIA	POULIE	RIEMENSCHLEIBE	PULLEY	Øe 160 Øi 65 4 SPB (220)		123849
1	68059600	1	PULEGGIA	POULIE	RIEMENSCHLEIBE	PULLEY	Ø 160 3 SPB (130-160)	123850	
1	68060500	1	PULEGGIA	POULIE	RIEMENSCHLEIBE	PULLEY	Ø 160 4 SPB (190-220)	123850	
2	68059500	1	CALETTATORE	DOUILLE DE SERRAGE	SPANNBÜCHSE	LOCKING DEVICE	Øe 65 Øi 40		
3	68060800		CINGHIA	COURROIE	KEILRIEMEN	BELT	B 45		
4	68079200	1	PULEGGIA	POULIE	RIEMENSCHLEIBE	PULLEY	Øe 120 Øi 65 2 SPB (130-140)		123849
4	68079300	1	PULEGGIA	POULIE	RIEMENSCHLEIBE	PULLEY	Øe 120 Øi 65 3 SPB (160-190)		123849
4	68082400	1	PULEGGIA	POULIE	RIEMENSCHLEIBE	PULLEY	Øe 120 Øi 65 4 SPB (220)		123849
4	68079300	1	PULEGGIA	POULIE	RIEMENSCHLEIBE	PULLEY	Ø 120 3 SPB (130-160)	123850	
4	68082400	1	PULEGGIA	POULIE	RIEMENSCHLEIBE	PULLEY	Ø 120 4 SPB (190-220)	123850	
5	60026700	10	VITE	VIS	SCHRAUBE	SCREW	TE 14x30 UNI 5739 8.8 ZNT		
6	64001800	2	INGRASSATORE	GRAISSEUR	SCHMIERNIPPEL	GREASE FITTING	M10 x 1 DIRITTO		
7	62010800	10	DADO	ECROU	MUTTER	NUT	M 14 x 2 AUTOBLOCC.		
8	32097600	2	DISTANZIALE	ENTRETOISE	DISTANZSTÜCK	SPACER			
9	66014100	1	ANELLO TENUTA	JOINT D'ETANCHEITE	DICHTUNGSRING	JUNT RING	45x65x6 "G"		
10	40120800	1	SUPPORTO SX	SUPPORT (G)	HALTER (LINKS)	SUPPORT (LH)			
11	67014500	2	CUSCINETTO	ROULEMENT	LAGER	BEARING	1309		
12	68011000		SPESSORE	EPAISSEUR	BEILAGERING	SPACER	55 x 45 x 1		
13	39129100	2	PROTEZIONE	PROTECTION	SCHUTZ	GUARD			
14	42084300	1	ROTORE	ROTOR	ROTOR	ROTOR	(130)		
14	42084400	1	ROTORE	ROTOR	ROTOR	ROTOR	(140)		
14	42084500	1	ROTORE	ROTOR	ROTOR	ROTOR	(160)		
14	42084600	1	ROTORE	ROTOR	ROTOR	ROTOR	(190)		
14	42084700	1	ROTORE	ROTOR	ROTOR	ROTOR	(220)		

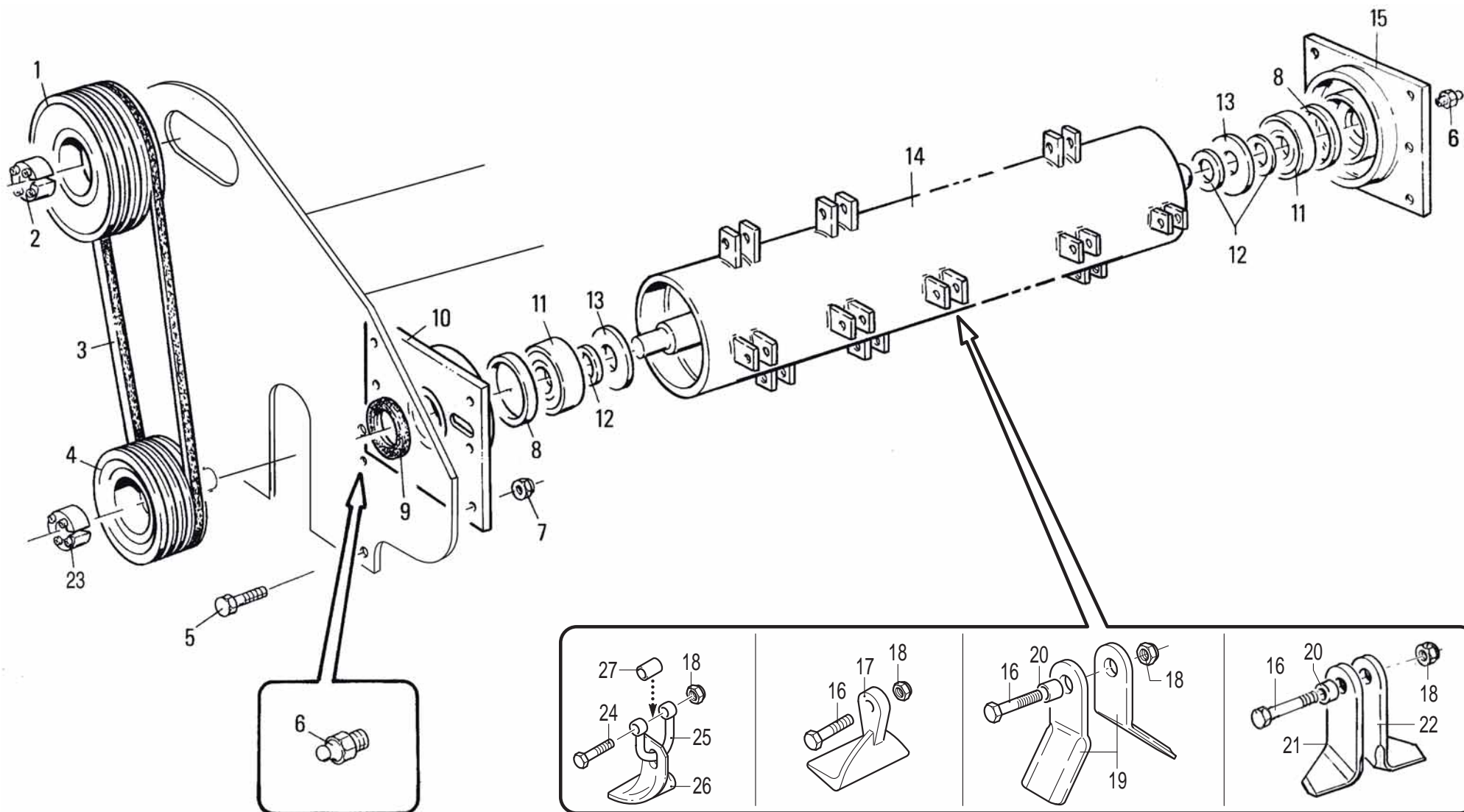

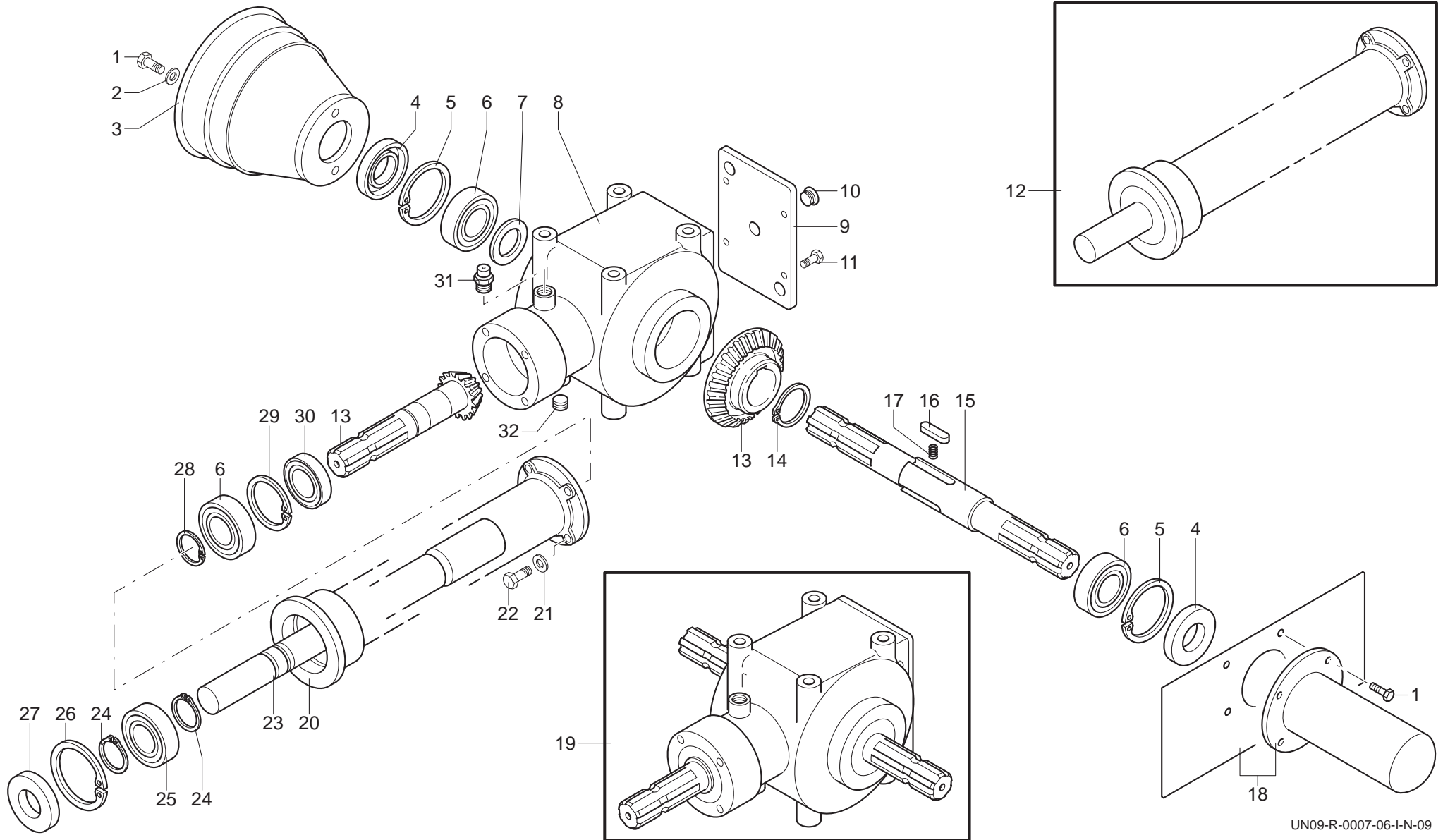

MURATORI MT 23
TAV. 7.0

POS.	N° CODICE	Q.	DESCRIZIONE	DESIGNATION	BENENNUNG	DESCRIPTION	DESIGNAZIONE	Da matr. De nr. serie Vom Seriennr. From serial nr.	Fino matr. Jusqu'au nr. serie Bis Seriennr. Up to serial nr.
1	60015100	8	VITE	VIS	SCHRAUBE	SCREW	TE 8 x 16 UNI 5739		
2	61006200	8	RONDELLA	RONDELLE	SCHEIBE	WASHER	PIANA Øi 9 Øe 24		
3	68061501	1	PROTEZIONE	PROTECTION	SCHUTZ	GUARD			
4	66014800	2	ANELLO TENUTA	JOINT D'ETANCHEITE	DICHTUNGSRING	JUNT RING	35x72x10		
5	63000300	2	ANELLO ELASTICO	BAGUE	SPANNRING	SNAP-RING	Ø 72 I		
6	67003700	3	CUSCINETTO	ROULEMENT	LAGER	BEARING	6207		
7	32190700	1	DISTANZIALE	ENTRETOISE	DISTANZSTÜCK	SPACER			
8	01015800	1	SCATOLA	CARTER	GEHÄUSE	GEARBOX			
9	03002100	1	COPERCHIO	COUVERCLE	DECKEL	COVER			
10	68008700	3	TAPPO	BOUCHON	STOPFEN	PLUG			
11	60022800	4	VITE	VIS	SCHRAUBE	SCREW	TE 8 x 20 UNI 5739 8.8 ZNT		
12	45112000	1	PROLUNGA	RALLONGE	VERLÄNGERUNGSROHR	EXTENSION	(130)		
12	45112100	1	PROLUNGA	RALLONGE	VERLÄNGERUNGSROHR	EXTENSION	(140-160)		
12	45112200	1	PROLUNGA	RALLONGE	VERLÄNGERUNGSROHR	EXTENSION	(190-220)		
13	10048800	1	COPPIA CONICA	COUPLE CONIQUE	KEGELRADTRIEB.	BEVEL GEAR PAIR			
14	63007600	1	ANELLO ELASTICO	BAGUE	SPANNRING	SNAP-RING			
15	31092700	1	ALBERO	ARBRE	WELLE	SHAFT			
16	68102700	3	CHIAVETTA	CLAVETTE	KEIL	SPLINE			
17	68102800	3	MOLLA	RESSORT	FEDER	SPRING			
18	39297400	1	PROTEZIONE	PROTECTION	SCHUTZ	GUARD	(130)		
18	39297500	1	PROTEZIONE	PROTECTION	SCHUTZ	GUARD	(140-220)		
19	46039100	1	MOLTIPLICATORE	MULTIPLICATEUR	GETRIEBE	GEAR BOX			
20	40179000	1	TUBO	TUBE	ROHR	TUBE	(130)		
20	40179100	1	TUBO	TUBE	ROHR	TUBE	(140-160)		
20	40179200	1	TUBO	TUBE	ROHR	TUBE	(190-220)		
21	61000600	4	RONDELLA	RONDELLE	SCHEIBE	WASHER	DENT. Ø 8 UNI 3704		

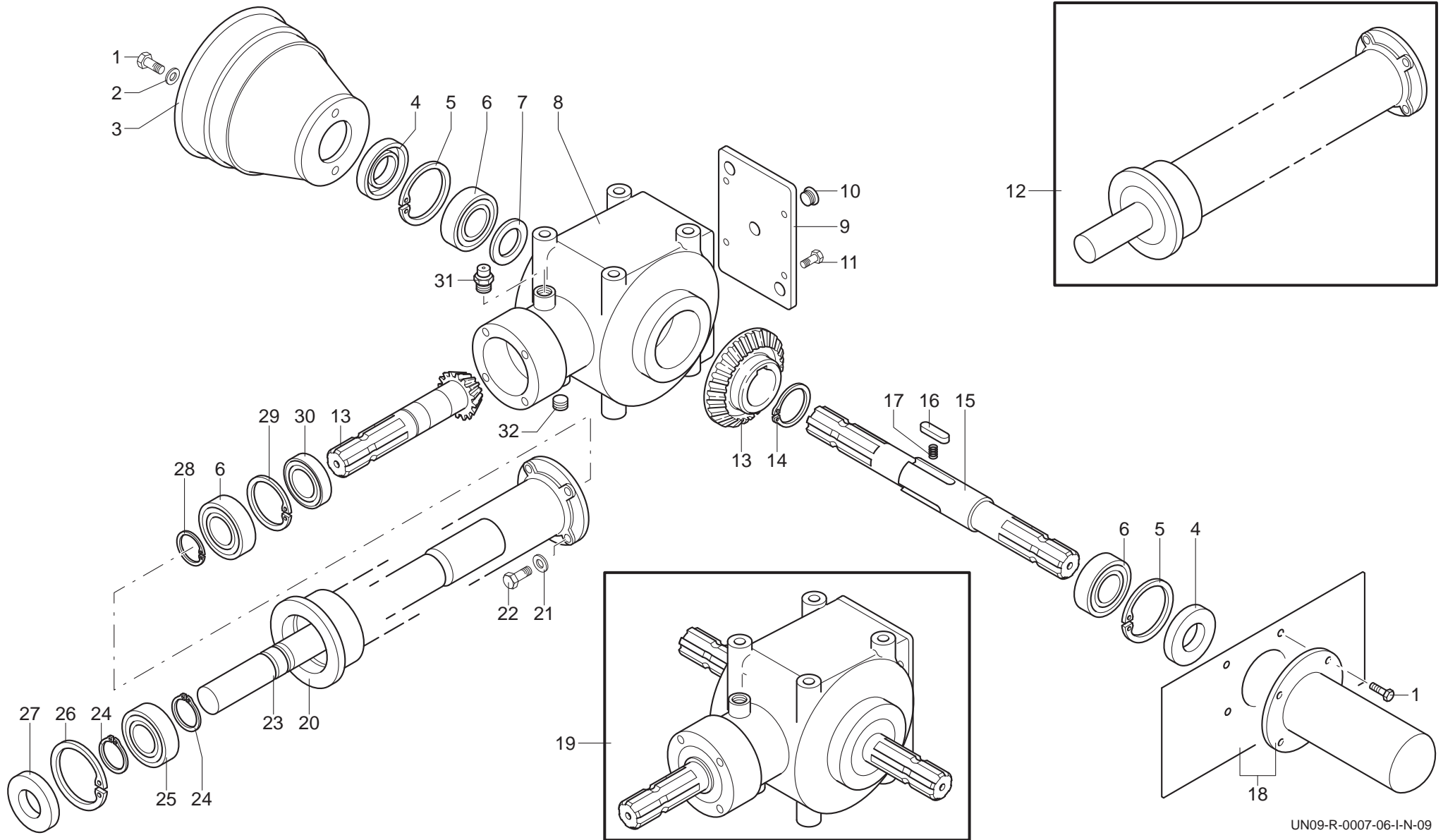

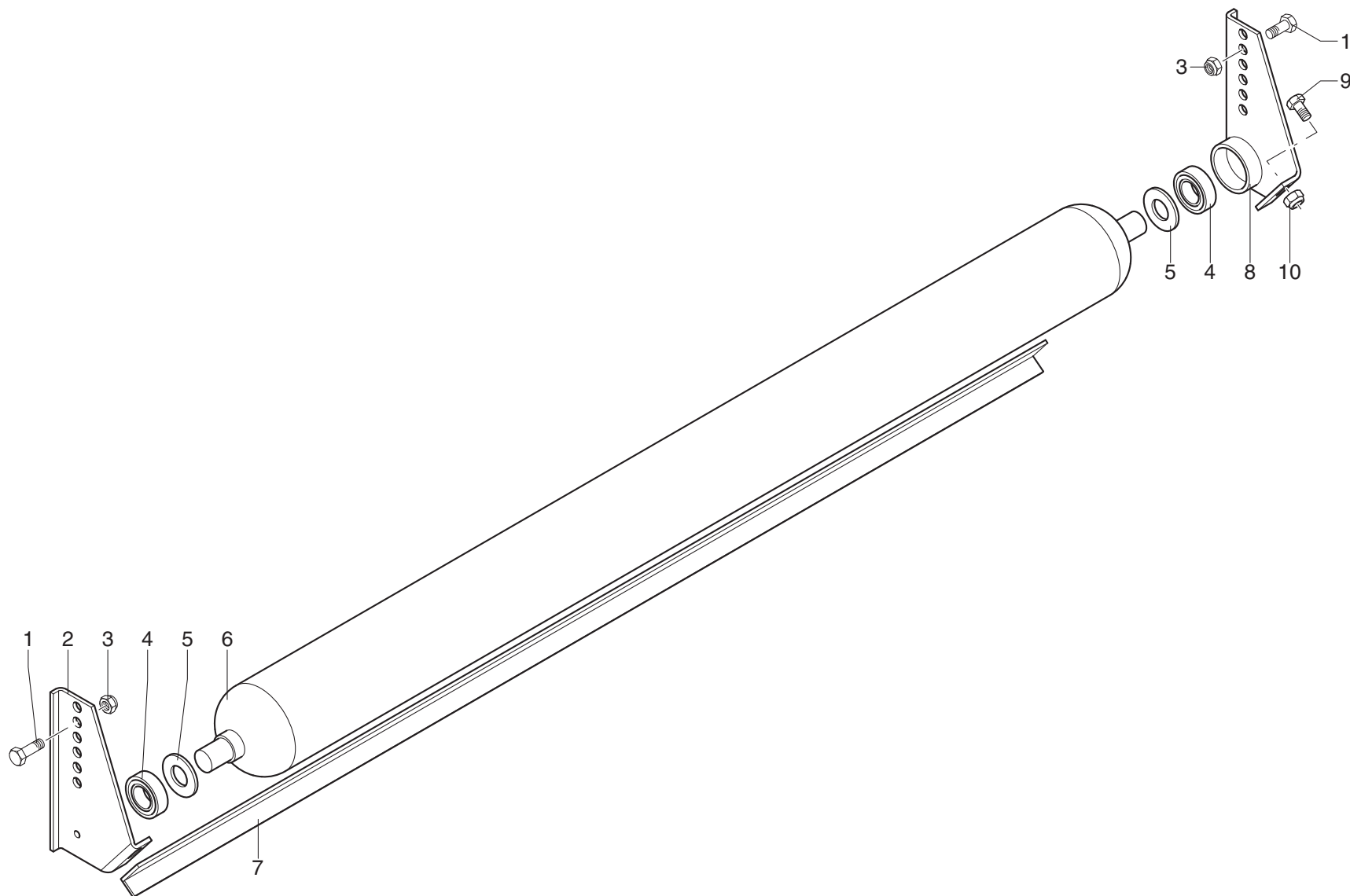

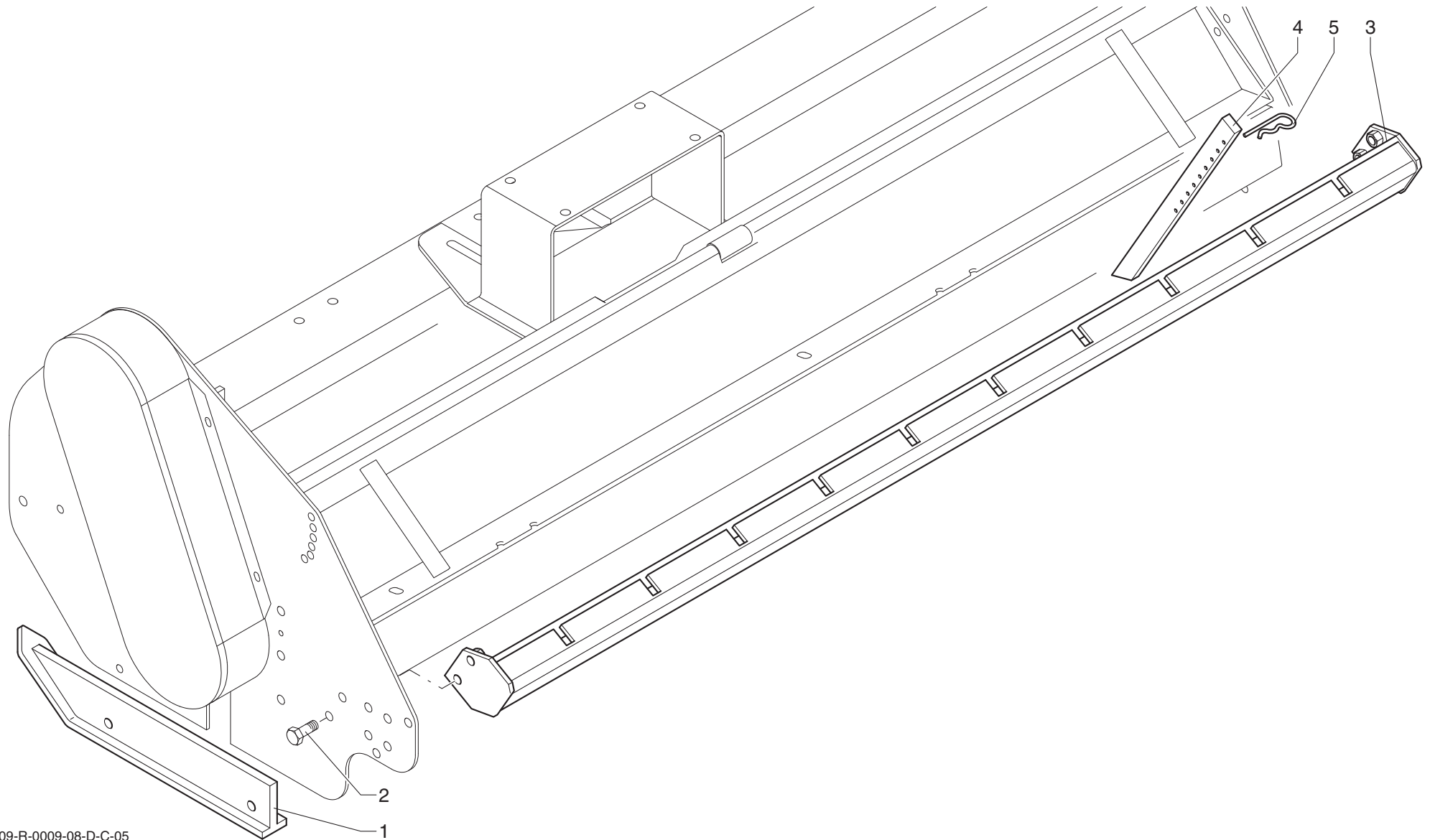

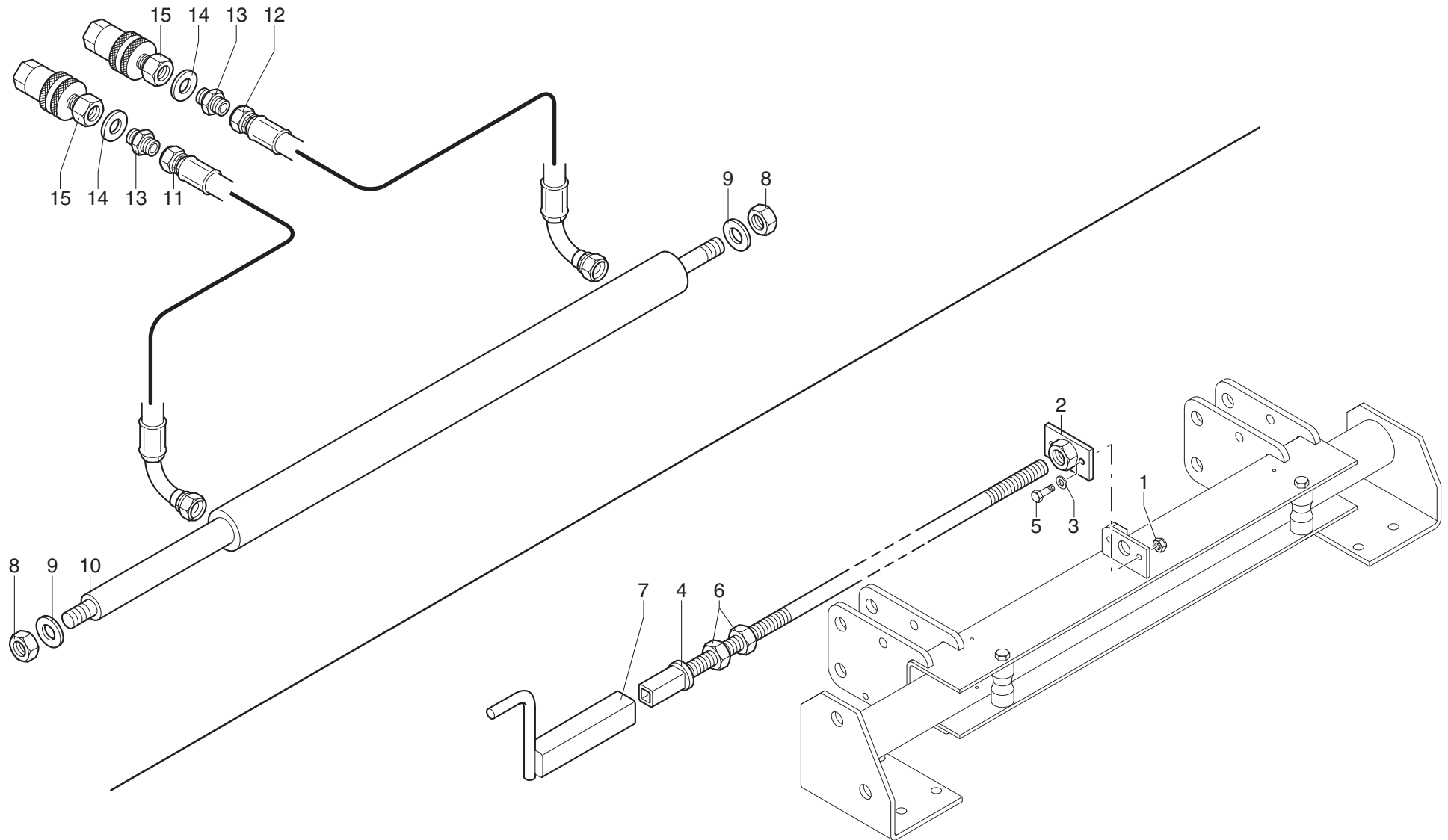

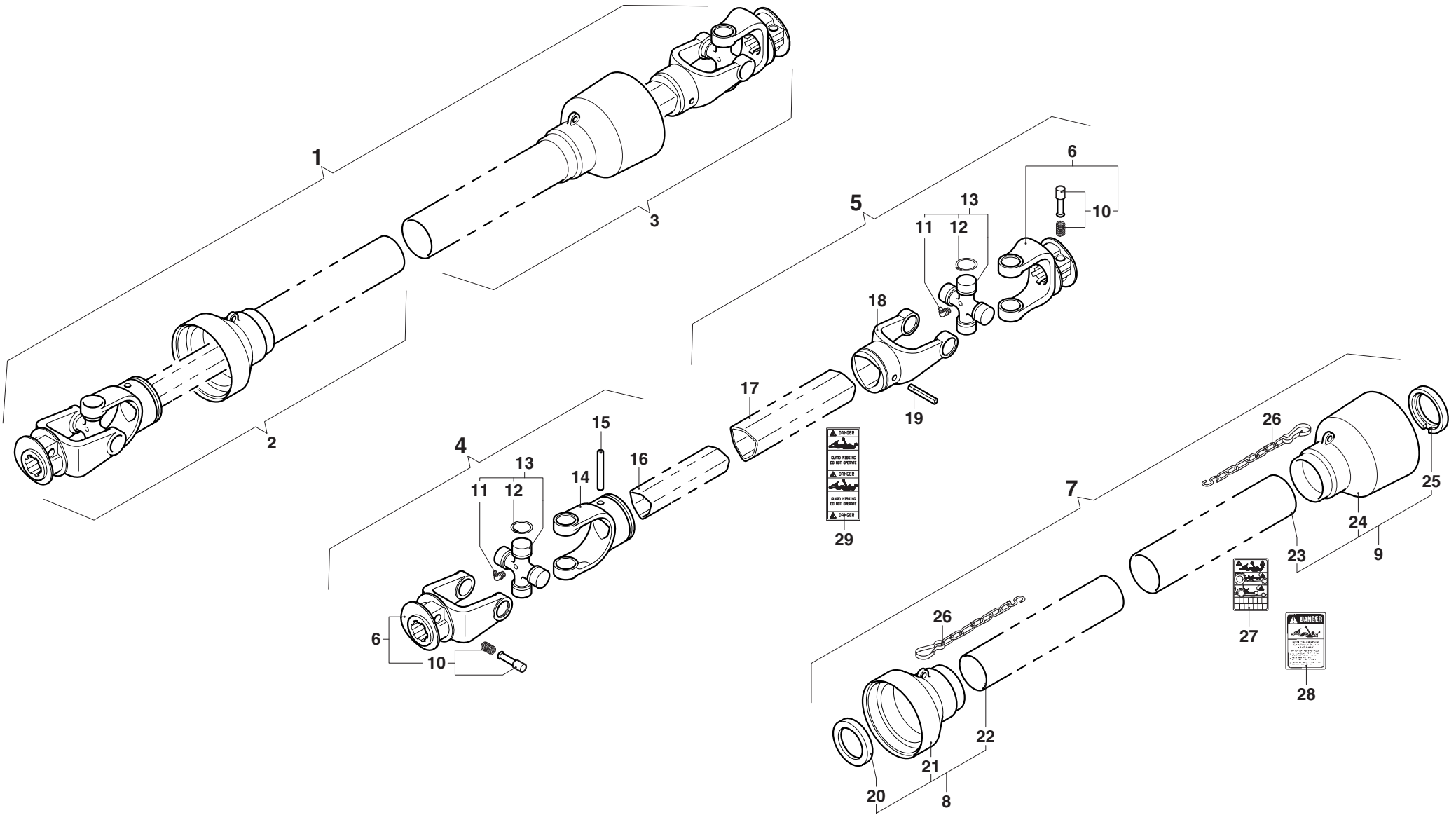

MURATORI MT 23

TAV. 10.0

POS.	N° CODICE	Q.	DESCRIZIONE	DESIGNATION	BENENNUNG	DESCRIPTION	DESIGNAZIONE	Da matr. De nr. serie Vom Seriennr. From serial nr.	Fino matr. Jusqu'au nr. serie Bis Seriennr. Up to serial nr.
1	AB409SF	1	ALBERO CARDANICO COMPLETO	ARBRE A JOINTS DE CARDAN	KARDANWELLE	PTO SHAFT			
2	B4090B1	1	SEMIALBERO INTERNO	DEMI-ARBRE INTERIEUR	INNENHALBWELLE	INTERNAL HALF SHAFT			
3	B4090B2	1	SEMIALBERO ESTERNO	DEMI-ARBRE EXTERIEUR	AUSSENHALBWELLE	EXTERNAL HALF SHAFT			
4	B409001	1	SEMIALBERO INTERNO	DEMI-ARBRE INTERIEUR	INNENHALBWELLE	INTERNAL HALF SHAFT			
5	B409002	1	SEMIALBERO ESTERNO	DEMI-ARBRE EXTERIEUR	AUSSENHALBWELLE	EXTERNAL HALF SHAFT			
6	0800403	2	FORCELLA	FOURCHE	GABEL	YOKE			
7	083B04090	1	PROTEZIONE	PROTECTION	SCHUTZ	GUARD			
8	083B040901	1	PROTEZIONE INTERNA	PROTECTION INTERIEURE	INNENSCHUTZ	INTERNAL GUARD			
9	083B040902	1	PROTEZIONE ESTERNA	PROTECTION EXTERIEURE	AUSSENSCHUTZ	EXTERNAL GUARD			
10	0986014047	2	PULSANTE	BOUTON	DRUCKKNOPF	PUSH BOTTON			
11	09840081002	2	INGRASSATORE	GRAISSEUR	SCHMIERNIPPEL	GREASE FITTING			
12	09802027	8	ANELLO ELASTICO	ARRETOIR	SPANNRING	SNAP-RING			
13	08204	2	CROCIERA	CROISILLON	KREUZSTÜCK	SPIDER			
14	08004011	1	FORCELLA	FOURCHE	GABEL	YOKE			
15	098700855	1	SPINA ELASTICA	GOUPILLE ELASTIQUE	SPANNSTIFT	ELASTIC PIN			
16	09881364100	1	TUBO INTERNO	TUBE INTERIEUR	INNENROHR	INTERNAL TUBE			
17	09881433100	1	TUBO ESTERNO	TUBE EXTERIEUR	AUSSENROHR	EXTERNAL TUBE			
18	08004021	1	FORCELLA	FOURCHE	GABEL	YOKE			
19	098700860	1	SPINA ELASTICA	GOUPILLE ELASTIQUE	SPANNSTIFT	ELASTIC PIN			
20	0265240008	1	GHIERA	FRETTE	NUTMUTTER	RING NUT			
21	0256040425	1	CUFFIA	CAPOUCHON	HAUBE	GUARD			
22	0988961B4090	1	TUBO INTERNO	TUBE INTERIEUR	INNENROHR	INTERNAL TUBE			
23	0988966B4090	1	TUBO ESTERNO	TUBE EXTERIEUR	AUSSENROHR	EXTERNAL TUBE			
24	0256040424	1	CUFFIA	CAPOUCHON	HAUBE	GUARD			
25	0265240007	1	GHIERA	FRETTE	NUTMUTTER	RING NUT			

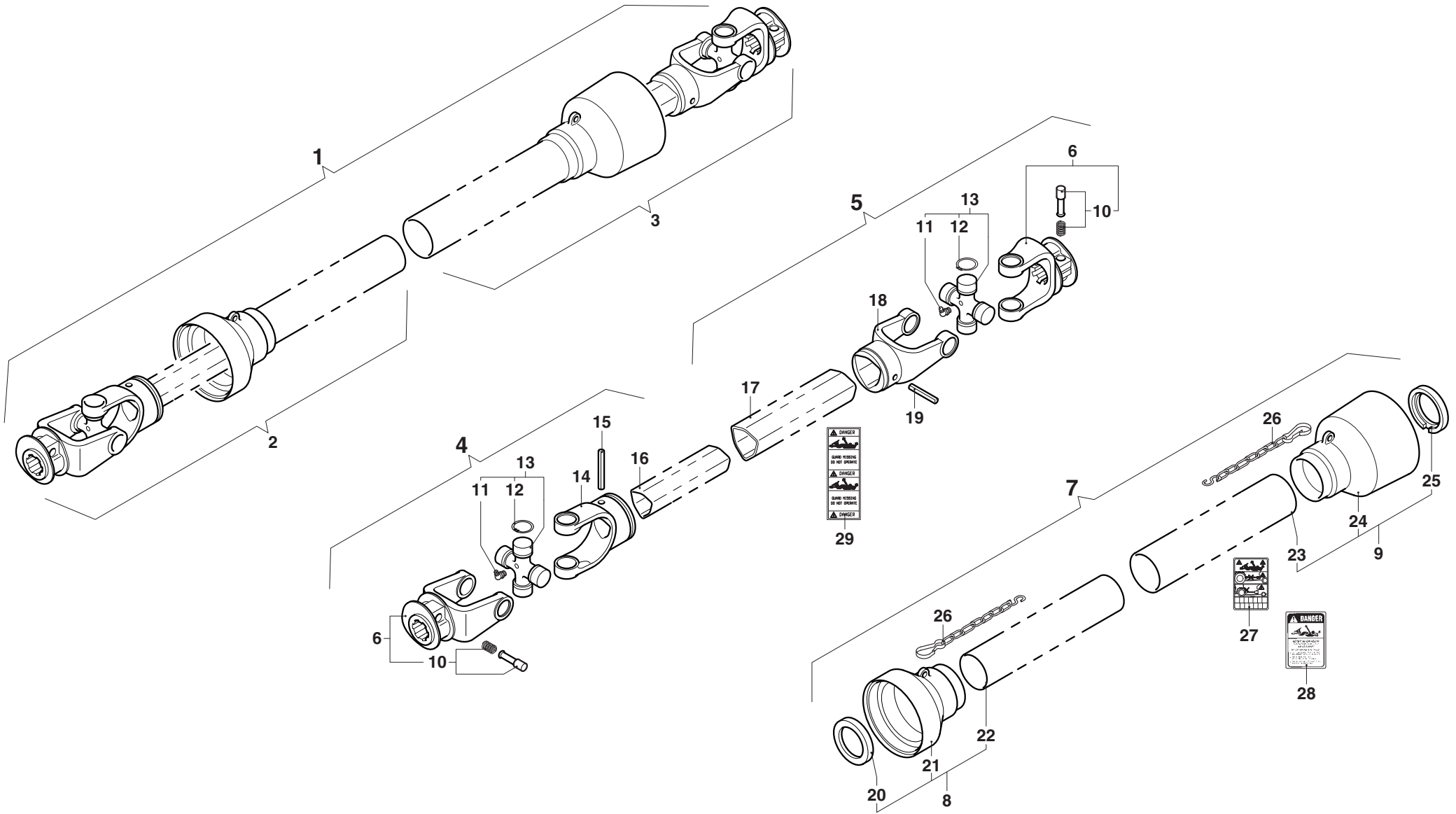

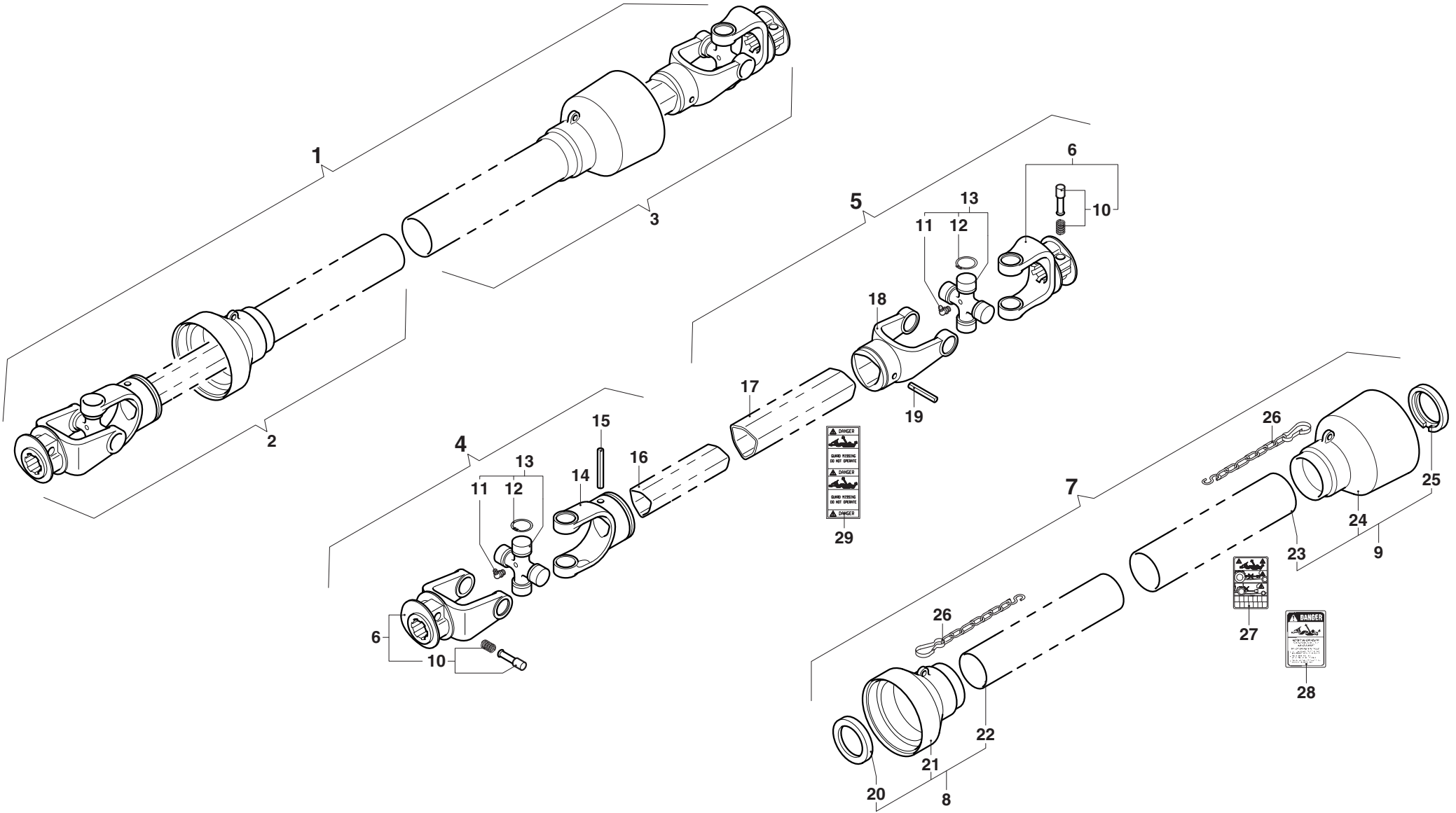

MURATORI MT 23

TAV. 11.0

POS.	N° CODICE	Q.	DESCRIZIONE	DESIGNATION	BENENNUNG	DESCRIPTION	DESIGNAZIONE	Da matr. De nr. serie Vom Seriennr. From serial nr.	Fino matr. Jusqu'au nr. serie Bis Seriennr. Up to serial nr.
1	AB509SF	1	ALBERO CARDANICO COMPLETO	ARBRE A JOINTS DE CARDAN	KARDANWELLE	PTO SHAFT			
2	B5090B1	1	SEMIALBERO INTERNO	DEMI-ARBRE INTERIEUR	INNENHALBWELLE	INTERNAL HALF SHAFT			
3	B5090B2	1	SEMIALBERO ESTERNO	DEMI-ARBRE EXTERIEUR	AUSSENHALBWELLE	EXTERNAL HALF SHAFT			
4	B509001	1	SEMIALBERO INTERNO	DEMI-ARBRE INTERIEUR	INNENHALBWELLE	INTERNAL HALF SHAFT			
5	B509002	1	SEMIALBERO ESTERNO	DEMI-ARBRE EXTERIEUR	AUSSENHALBWELLE	EXTERNAL HALF SHAFT			
6	0800503	2	FORCELLA	FOURCHE	GABEL	YOKE			
7	083B05090	1	PROTEZIONE	PROTECTION	SCHUTZ	GUARD			
8	083B050901	1	PROTEZIONE INTERNA	PROTECTION INTERIEURE	INNENSCHUTZ	INTERNAL GUARD			
9	083B050902	1	PROTEZIONE ESTERNA	PROTECTION EXTERIEURE	AUSSENSCHUTZ	EXTERNAL GUARD			
10	0986014047	2	PULSANTE	BOUTON	DRUCKKNOPF	PUSH BOTTON			
11	09840081002	2	INGRASSATORE	GRAISSEUR	SCHMIERNIPPEL	GREASE FITTING			
12	09802030	8	ANELLO ELASTICO	ARRETOIR	SPANNRING	SNAP-RING			
13	08205	2	CROCIERA	CROISILLON	KREUZSTÜCK	SPIDER			
14	08005011	1	FORCELLA	FOURCHE	GABEL	YOKE			
15	098700865	1	SPINA ELASTICA	GOUPILLE ELASTIQUE	SPANNSTIFT	ELASTIC PIN			
16	09881454100	1	TUBO INTERNO	TUBE INTERIEUR	INNENROHR	INTERNAL TUBE			
17	09881523100	1	TUBO ESTERNO	TUBE EXTERIEUR	AUSSENROHR	EXTERNAL TUBE			
18	08005021	1	FORCELLA	FOURCHE	GABEL	YOKE			
19	098700870	1	SPINA ELASTICA	GOUPILLE ELASTIQUE	SPANNSTIFT	ELASTIC PIN			
20	0265250008	1	GHIERA	FRETTE	NUTMUTTER	RING NUT			
21	0256050425	1	CUFFIA	CAPOUCHON	HAUBE	GUARD			
22	0988975B5090	1	TUBO INTERNO	TUBE INTERIEUR	INNENROHR	INTERNAL TUBE			
23	0988981B5090	1	TUBO ESTERNO	TUBE EXTERIEUR	AUSSENROHR	EXTERNAL TUBE			
24	0256050424	1	CUFFIA	CAPOUCHON	HAUBE	GUARD			
25	0265250007	1	GHIERA	FRETTE	NUTMUTTER	RING NUT			

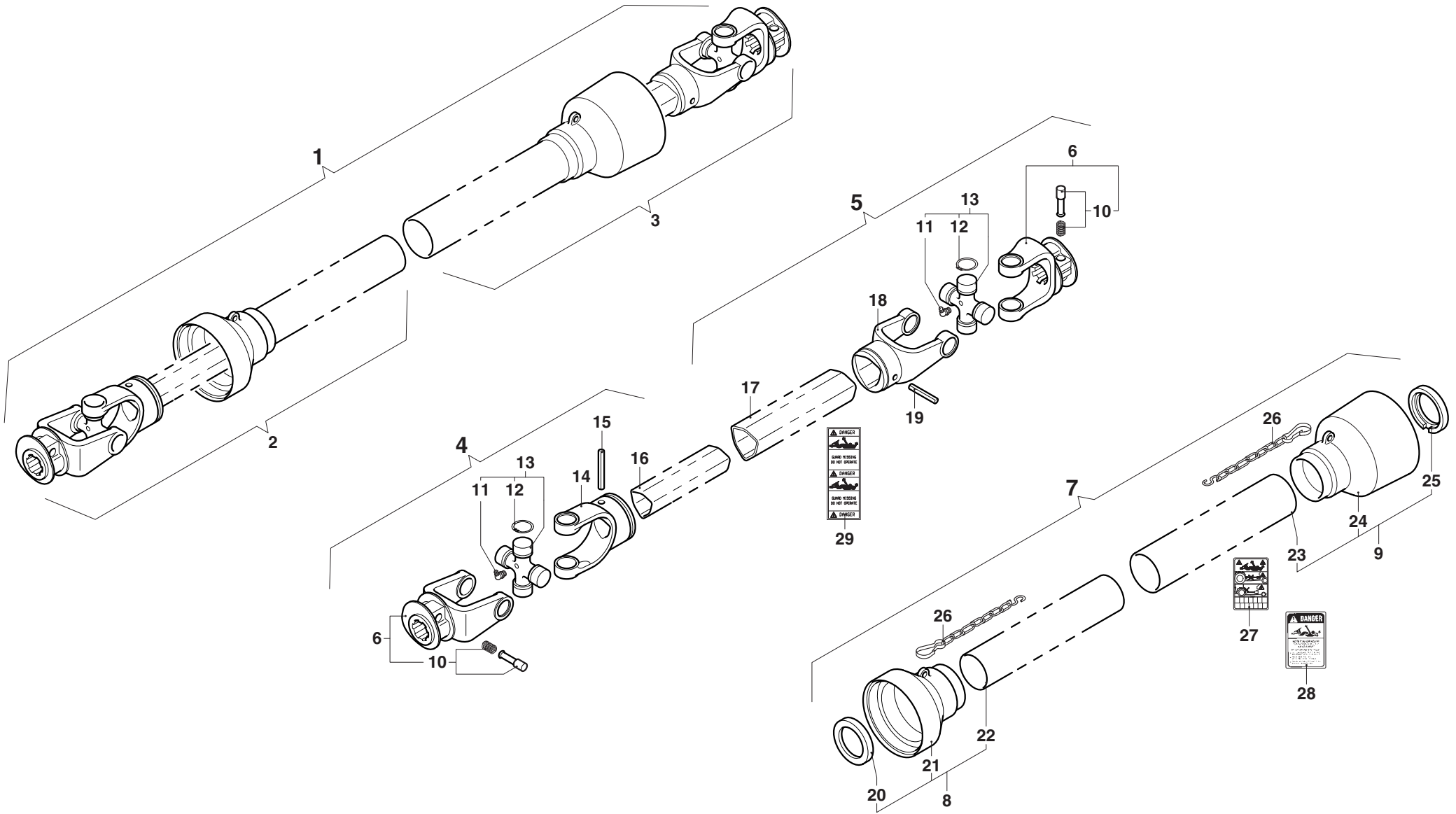



MURATORI S.p.A.

Via Pavarello, 21 - 41051 Castelnuovo Rangone (MO) Italy - Tel. 059.5330611 Fax 059.537259

www.muratoriequip.it *info@muratoriequip.it*

Capitale sociale Euro 480.000 interamente versato

Registro Imprese di Modena

Codice fiscale e numero d'iscrizione: 00708860366