



# MURATORI

**TIPO-TYPE-TYP  
MZ4**

**CATALOGO RICAMBI**  
**Catalogue Pièces Detachées**  
**Ersatzteilkatalog**  
**Spare Parts Catalogue**  
**Catálogo Recambios**

**EDIZIONE 10/2015**



Per ordinare parti di ricambio specificare:

- tipo e matricola della macchina (apposti sulla macchina o sui documenti di acquisto);
- numero del riferimento del pezzo nel disegno (Pos.), numero della tavola (Tav.) e numero di codice

**N.B.:** le indicazioni destro o sinistro vengono date guardando la macchina da dietro.

*Pour les commandes de pièces de rechange veuillez spécifier:*

- *type et numéro de série de la machine (indiqués sur la machine et sur le bon d'achat);*
- *numéro de référence du pièce sur le plan (Pos.), numéro du plan (Tav.) et numéro de code (codice)*

**N.B.:** *les indications droite ou gauche sont données en regardant la machine par derrière.*

Zum Bestellen von Ersatzteilen folgendes angeben:

- Typ und Serien-Nr. der Maschine (zu finden auf der Maschine oder der Einkaufspapieren);
- Bezug-Nr. des Ersatzteils auf der Zeichnung (Pos.), Zeichnungsnummer (Tav.) und Kodenummer (codice)

**N.B.:** die Angaben rechts und links verstehen sich so, dass man hinter der Maschine steht.

*When ordering spare parts specify:*

- *machine type and serial number (found on the machine or on the purchasing documents);*
- *reference number of the part on the relative drawing (Pos.) number of the drawing (Tav.) and part number (codice)*

**N.B.:** *right-hand or left-hand indications are made by viewing the machine from the rear.*

**TAV. 1.0**

GRUPPO TELAIO  
ENSEMBLE CHASSIS  
SATZ FÜR RAHMEN  
KIT FOR FRAME

**TAV. 2.0**

GRUPPO RULLO ROTORE STANDARD A 4 ZAPPE  
ENSEMBLE ROTOR STANDARD A 4 LAMES  
SATZ FÜR STANDARDROTOR ZU 4 MESSER  
KIT FOR STANDARD ROTOR 4 BLADES

**TAV. 2.1**

GRUPPO RULLO ROTORE A 6 ZAPPE  
ENSEMBLE ROTOR A 6 LAMES  
SATZ FÜR ROTOR ZU 6 MESSER  
KIT FOR ROTOR 6 BLADES

**TAV. 3.0**

GRUPPO RIDUTTORE A 1 VELOCITA'  
ENSEMBLE BOITIER MONOVITNESS  
SATZ FÜR EINGANGGETRIEBE  
KIT FOR ONE-SPEED GEAR BOX

**TAV. 4.0**

PROTEZIONI ANTINFORTUNISTICHE "CE"  
PROTECTIONS "CE"  
UNFALLSCHUTZVORRICHTUNGEN "CE"  
SAFETY GUARDS "CE"

**TAV. 5.0** Fino matr. - *Jusqu'au nr. série* - Bis Seriennr. - *Up to serial nr.* **114651**

ALBERO CARDANICO COMPLETO - AE408SF  
ARBRE A JOINTS DE CARDAN - AE408SF  
KARDANWELLE - AE408SF  
PTO SHAFT - AE408SF

**TAV. 5.1** Da matr. - *De nr. série* - Vom Seriennr. - *From serial nr.* **114652**

ALBERO CARDANICO COMPLETO - AB408SFDO  
ARBRE A JOINTS DE CARDAN - AB408SFDO  
KARDANWELLE - AB408SFDO  
PTO SHAFT - AB408SFDO

**TAV. 6.0** Fino matr. - *Jusqu'au nr. série* - Bis Seriennr. - *Up to serial nr.* **131048**

ALBERO CARDANICO COMPLETO - AE408FSBDO  
ARBRE A JOINTS DE CARDAN - AE408FSBDO  
KARDANWELLE - AE408FSBDO  
PTO SHAFT - AE408FSBDO

**TAV. 6.1** Da matr. - *De nr. série* - Vom Seriennr. - *From serial nr.* **131049**

ALBERO CARDANICO COMPLETO - AB408FSBDO  
ARBRE A JOINTS DE CARDAN - AB408FSBDO  
KARDANWELLE - AB408FSBDO  
PTO SHAFT - AB408FSBDO

**TAV. 7.0** Fino matr. - *Jusqu'au nr. série* - Bis Seriennr. - *Up to serial nr.* **117536**

ALBERO CARDANICO COMPLETO - AF408FF1  
ARBRE A JOINTS DE CARDAN - AF408FF1  
KARDANWELLE - AF408FF1  
PTO SHAFT - AF408FF1

**TAV. 7.1** Da matr. - *De nr. série* - Vom Seriennr. - *From serial nr.* **117537**

ALBERO CARDANICO COMPLETO - AB408FF1DO  
ARBRE A JOINTS DE CARDAN - AB408FF1DO  
KARDANWELLE - AB408FF1DO  
PTO SHAFT - AB408FF1DO

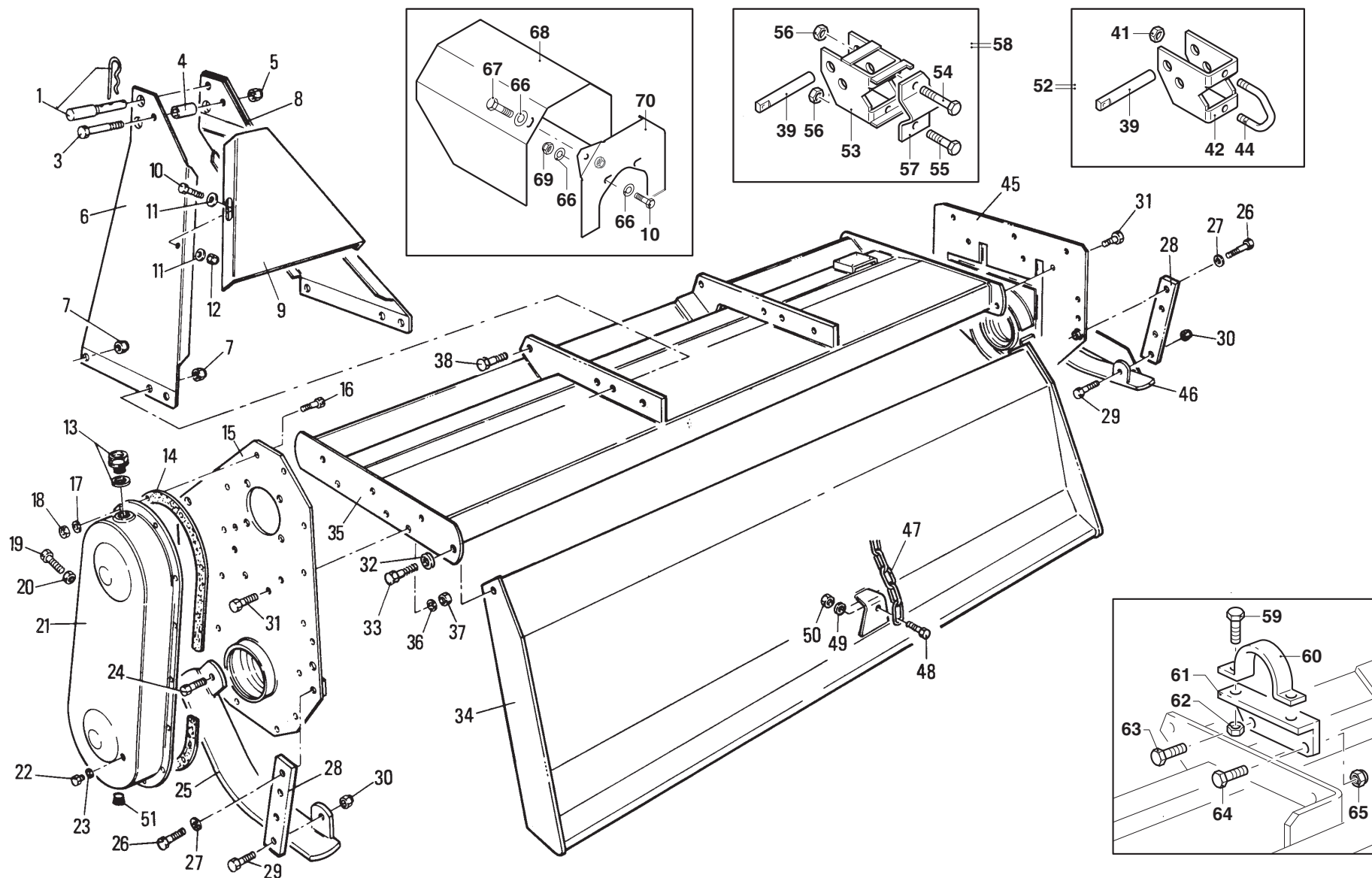

# MURATORI MZ4

# TAV. 1.0

POS.	N° CODICE	Q	DESCRIZIONE	DESIGNATION	BENENNUNG	DESCRIPTION	DESIGNAZIONE	Da matr. De nr. serie Vom Seriennr. From serial nr.	Fino matr. Jusqu'au nr. serie Bis Seriennr. Up to serial nr.
1	68062000	1	PERNO	PIVOT	BOLZEN	PIN	Ø 19 mm 135		
3	60021500	1	VITE	VIS	SCHRAUBE	SCREW	TE 12x80 UNI 5737 ZNT		
4	32069101	1	DISTANZIALE	ENTRETOISE	DISTANZSTÜCK	SPACER			
5	62010600	1	DADO	ECROU	MUTTER	NUT	M 12x1,75 autobloc.		
6	40295500	1	ARCATA SX	ARCADE (G)	ARKADE (LINKS)	ARCADE (LH)		25602	
7	62010600	6	DADO	ECROU	MUTTER	NUT	M 12x1,75 autobloc.	25602	
8	40295600	1	ARCATA DX	ARCADE (D)	ARKADE (RECHTS)	ARCADE (RH)		25602	
9	39097901	1	CHIUSURA	FERMATURE	VERSCHLUSS	LOCK		25602	
10	60022800	4	VITE	VIS	SCHRAUBE	SCREW	TE 8x20 UNI 5739 ZNT	25602	
11	61004700	4	RONDELLA	RONDELLE	SCHEIBE	WASHER	Piana Ø 8 UNI 6592 ZNT	25602	
12	62007200	2	DADO	ECROU	MUTTER	NUT	M 8x1,25 UNI 5587 ZNT	25602	
13	68000500	1	TAPPO	BOUCHON	STOPFEN	PLUG			
14	80005601	1	GUARNIZIONE	GARNITURE	DICHTUNG	SEAL			
15	40086001	1	PIASTRA CARTER	PLAQUE	SEITENWAND	SIDE FRAME			
16	60022800	10	VITE	VIS	SCHRAUBE	SCREW	TE 8x20 UNI 5739 8,8 ZNT		
17	61000600	10	RONDELLA	RONDELLE	SCHEIBE	WASHER	Dent. Int. Ø 8 UNI 3704		
18	62000700	10	DADO	ECROU	MUTTER	NUT	M 8x1,25 UNI 5587		
19	60027400	1	VITE	VIS	SCHRAUBE	SCREW	TE 14x70 UNI 5739 8,8		
20	62000100	1	DADO	ECROU	MUTTER	NUT	M 14x2 alto UNI 5587		
21	40010700	1	COPERCHIO	COUVERCLE	DECKEL	COVER			
22	60001100	1	VITE	VIS	SCHRAUBE	SCREW	TE 10x10 UNI 5739 4,8		
23	61000800	1	RONDELLA	RONDELLE	SCHEIBE	WASHER	Piana Ø 10 alluminio		
24	60044400	2	VITE	VIS	SCHRAUBE	SCREW	TE 12x20 UNI 5739 8,8 ZNT		
25	45000301	1	SLITTA SX	PATIN (G)	STUTZTKUFE (LINKS)	SKID (LH)			
26	60020400	2	VITE	VIS	SCHRAUBE	SCREW	TE 12x25 UNI 5739 8,8 ZNT		
27	61000500	2	RONDELLA	RONDELLE	SCHEIBE	WASHER	Dent. int. Ø 12 UNI 3704		

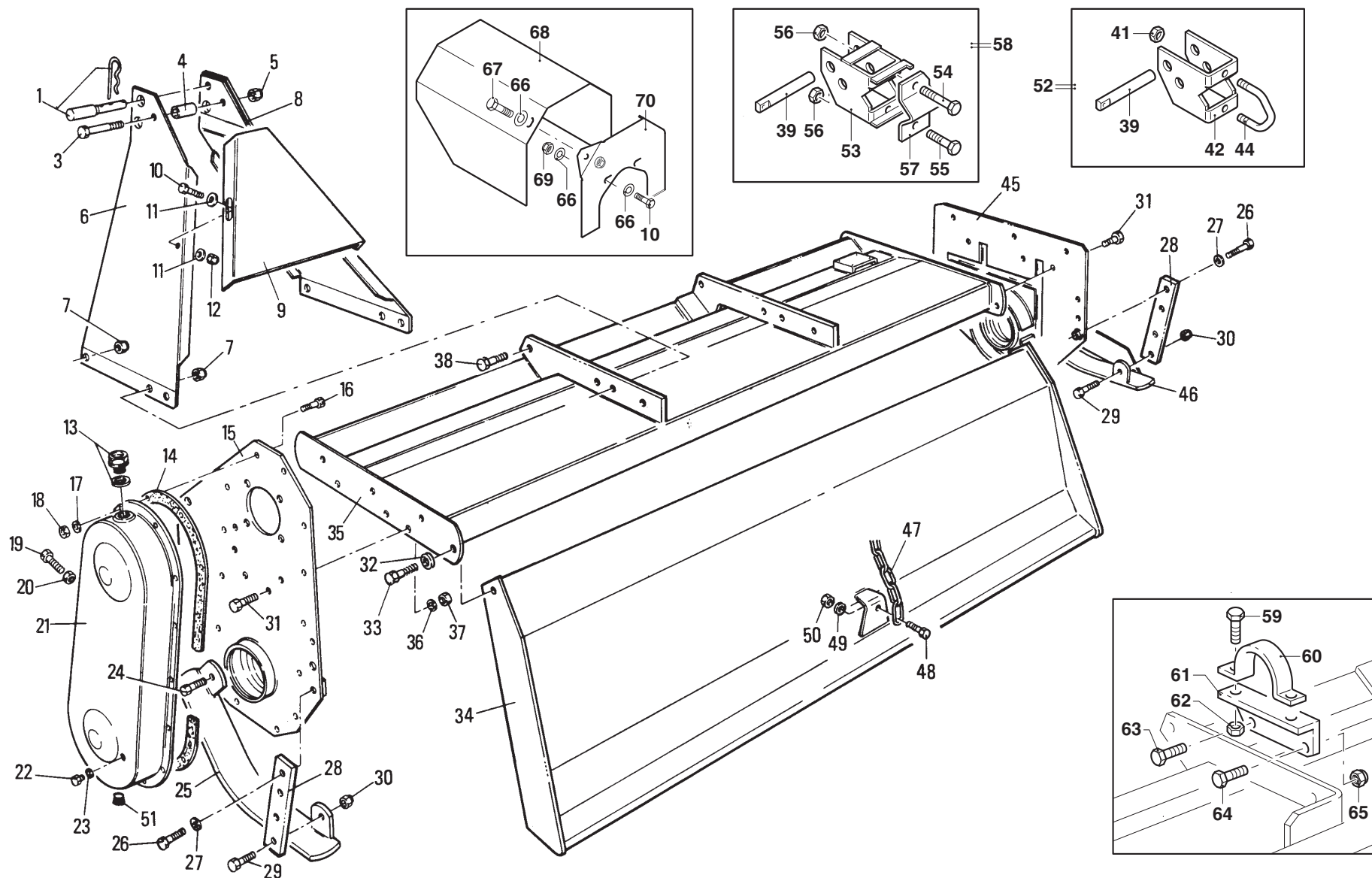

## MURATORI MZ4

## TAV. 1.0

POS.	N° CODICE	Q	DESCRIZIONE	DESIGNATION	BENENNUNG	DESCRIPTION	DESIGNAZIONE	Da matr.	Fino matr
								De nr. serie Vom Seriennr. From serial nr.	Jusqu'au nr. serie Bis Seriennr. Up to serial nr.
28	30001300	2	ASTA REGOLAZIONE	TIGE REGOLATION	TIEFEINSTELLUNGSSTANGE	DEPHT CONTROL ROD			
29	60020400	2	VITE	VIS	SCHRAUBE	SCREW	TE 12x25 UNI 5739 8,8		
30	62001100	2	DADO	ECROU	MUTTER	NUT	M 12x1,75 UNI 5589 8,8 ZNT		
31	60017900	8	VITE	VIS	SCHRAUBE	SCREW	TE 10x25 UNI 5739 8,8 ZNT		
32	60042700	2	VITE	VIS	SCHRAUBE	SCREW	TE 14x50 UNI 5739 8,8 ZNT		
33	61004500	2	RONDELLA	RONDELLE	SCHEIBE	WASHER	Grower Ø 14 UNI 1751		
34	41051901	1	COFANO	CAPOT	SCHUTZHAUBE	HOOD	105		
34	41052001	1	COFANO	CAPOT	SCHUTZHAUBE	HOOD	115		
34	41052101	1	COFANO	CAPOT	SCHUTZHAUBE	HOOD	125		
34	41052201	1	COFANO	CAPOT	SCHUTZHAUBE	HOOD	135		
34	41052301	1	COFANO	CAPOT	SCHUTZHAUBE	HOOD	145		
34	41115300	1	COFANO	CAPOT	SCHUTZHAUBE	HOOD	155		
34	41056701	1	COFANO	CAPOT	SCHUTZHAUBE	HOOD	165		
34	41120800	1	COFANO	CAPOT	SCHUTZHAUBE	HOOD	175		
35	41127400	1	TELAIO	CHASSIS	RAHMEN	FRAME	105		
35	41127500	1	TELAIO	CHASSIS	RAHMEN	FRAME	115		
35	41127600	1	TELAIO	CHASSIS	RAHMEN	FRAME	125		
35	41127700	1	TELAIO	CHASSIS	RAHMEN	FRAME	135		
35	41127800	1	TELAIO	CHASSIS	RAHMEN	FRAME	145		
35	41127900	1	TELAIO	CHASSIS	RAHMEN	FRAME	155		
35	41128000	1	TELAIO	CHASSIS	RAHMEN	FRAME	165		
35	41125600	1	TELAIO	CHASSIS	RAHMEN	FRAME	175		
36	61000400	8	RONDELLA	RONDELLE	SCHEIBE	WASHER	Dent. int. Ø 10 UNI 3704		
37	62000500	8	DADO	ECROU	MUTTER	NUT	M 10x1,5 UNI 5587		
38	60023000	6	VITE	VIS	SCHRAUBE	SCREW	TE 12x30 UNI 5739 ZNT		
39	68062300	2	PERNO	PIVOT	BOLZEN	PIN			

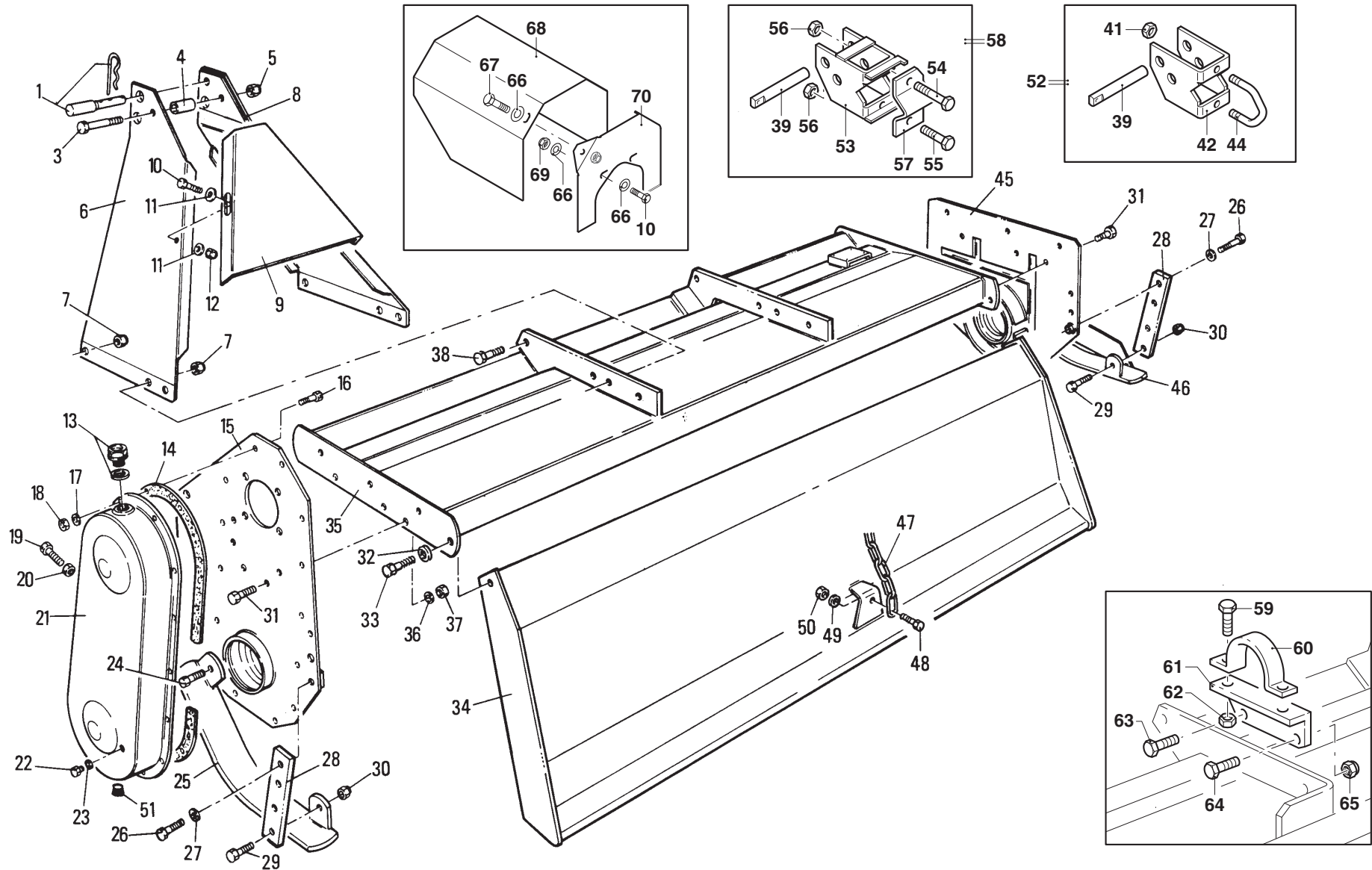

## MURATORI MZ4

TAV. 1.0

POS.	N° CODICE	Q	DESCRIZIONE	DESIGNATION	BENENNUNG	DESCRIPTION	DESIGNAZIONE	Da matr.	Fino matr
								De nr. serie Vom Seriennr. From serial nr.	Jusqu'au nr. serie Bis Seriennr. Up to serial nr.
41	62010600	4	DADO	ECROU	MUTTER	NUT	M 12x1,75 AUTOBLOCC.		
42	40262100	2	STAFFA	BRIDE	BÜGEL	BRACKET			
44	38022301	2	CAVALLOTTO	ARRETOIR	KLEMMSTÜCK	UBOLT			
45	40042402	1	FIANCO	FLANC	SEITENWAND	SIDE FRAME			
46	45004900	1	SLITTA DX	CHARIOT DX	KUFE (R)	SKID (RH)			
47	68041700	1	CATENA	CHAINE	KETTE	CHAIN			
48	60020400	1	VITE	VIS	SCHRAUBE	SCREW	TE 12x25 UNI 5739		
49	61005000	1	RONDELLA	RONDELLE	SCHEIBE	WASHER	PIANA Ø 12 UNI 6592		
50	62007100	1	DADO	ECROU	MUTTER	NUT	M 12x1,75 UNI 5587		
51	68008700	1	TAPPO	BOUCHON	STOPFEN	PLUG			
52	51001300	1	KIT STAFFA	KIT BRIDE	BUEGELSATZ	BRACKET KIT			115986
53	40262101	2	STAFFA	BRIDE	BUEGEL	BRACKET		115987	
54	60010100	2	VITE	VIS	SCHRAUBE	SCREW	TE 12x65 UNI 5737	115987	
55	60045400	2	VITE	VIS	SCHRAUBE	SCREW	TE 12x55 UNI 5737	115987	
56	62010600	4	DADO	ECROU	MUTTER	NUT	M12x1,75 AUTOBLOCC.	115987	
57	30197600	2	RITEGNO	FIXAGE	BEFESTIGUNG	CLAMP		115987	
58	51004200	1	KIT STAFFA	KIT BRIDE	BUEGELSATZ	BRACKET KIT		115987	
59	60017900	2	VITE	VIS	SCHRAUBE	SCREW	TE 10x25 UNI 5739		
60	30207300	1	AGGANCI	CROCHET	HAKEN	HOOK			
61	39312600	1	STAFFA	BRIDE	BÜGEL	BRACKET			
62	62010400	2	DADO	ECROU	MUTTER	NUT	M10 AUTOBLOCC.		
63	60023000	1	VITE	VIS	SCHRAUBE	SCREW	TE 12x30 UNI 5739		
64	60021200	1	VITE	VIS	SCHRAUBE	SCREW	TE 12x35 UNI 5739		
65	62010600	2	DADO	ECROU	MUTTER	NUT	M12x1,75 AUTOBLOCC.		
66	61006200	6	RONDELLA	RONDELLE	SCHEIBE	WASHER	PIANA Ø 9		
67	60015100	2	VITE	VIS	SCHRAUBE	SCREW	TE 8x16 UNI 5739		

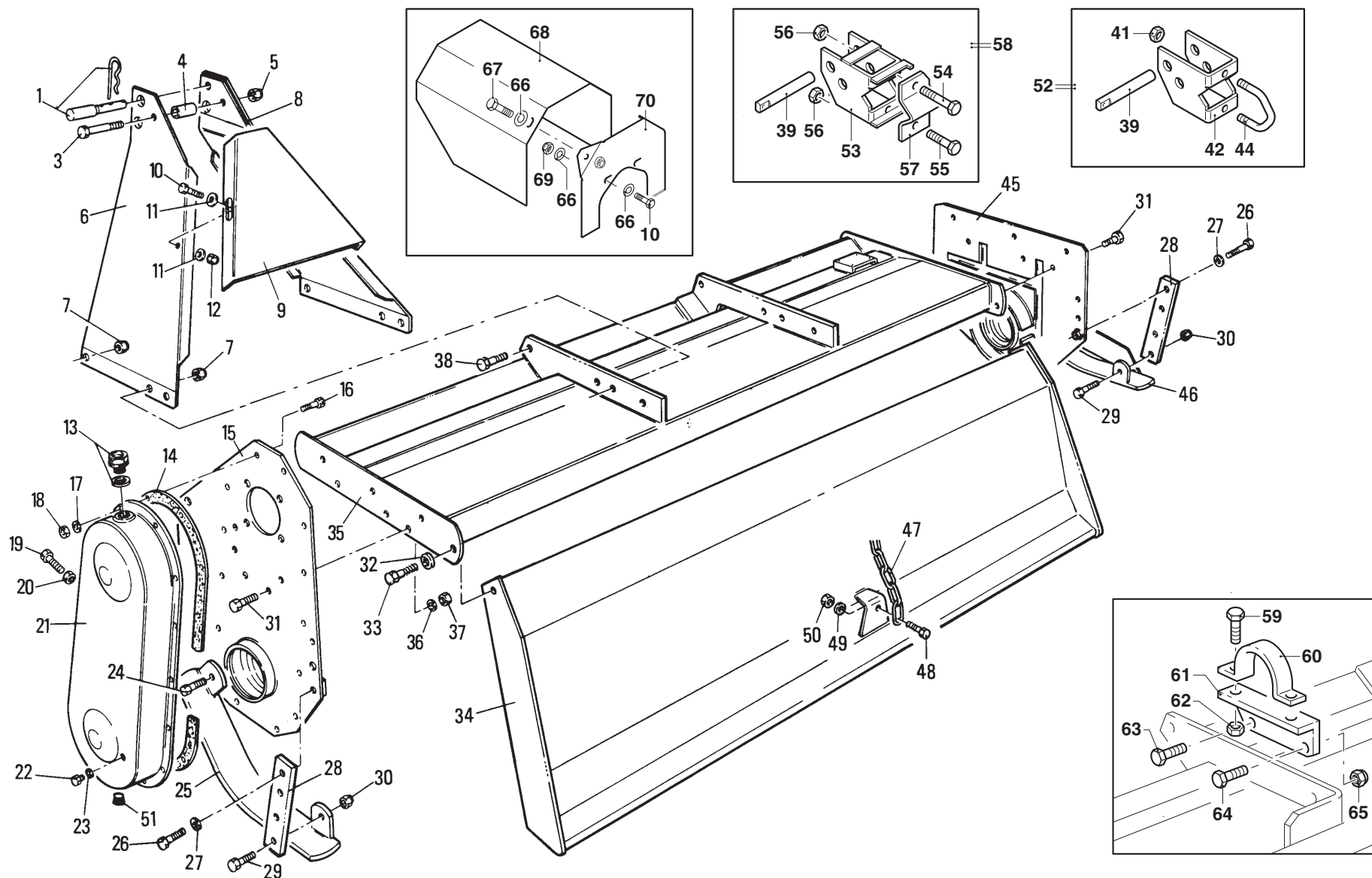





## MURATORI MZ4

## TAV. 2.0

POS.	N° CODICE	Q	DESCRIZIONE	DESIGNATION	BENENNUNG	DESCRIPTION	DESIGNAZIONE	Da matr.	Fino matr.
								De nr. serie Vom Seriennr. From serial nr.	Jusqu'au nr. serie Bis Seriennr. Up to serial nr.
1	63000700	1	ANELLO ELASTICO	ARRETOIR	SPANNRING	SNAP-RING	Ø 40 E UNI 7435		
2	10006501	1	PIGNONE	PIGNON	RITZEL	PINION	Z 10 1"		
2	10021300	1	PIGNONE SPECIALE	PIGNON SPECIALE	SONDERRITZEL	SPECIAL PINION	Z 11 1" giri maggiorati		
3	63000700	1	ANELLO ELASTICO	ARRETOIR	SPANNRING	SNAP-RING	Ø 40 E UNI 7435		
4	10006600	1	CORONA	COURONNE	KRANZ	CROWN	Z 17 1"		
4	10021400	1	CORONA SPECIALE	COURONNE SPECIAL	SONDER KRANZ	SPECIAL CROWN	Z 16 1" giri maggiorati		
5	63000200	1	ANELLO ELASTICO	ARRETOIR	SPANNRING	SNAP-RING	Ø 80 I UNI 7437		
6	67004400	1	CUSCINETTO	ROULEMENT	LAGER	BEARING	6208		
7	66002100	1	ANELLO TENUTA	JOINT D'ETANCHEITE	DICHTUNGSRING	JUNT RING	45x72x10		
8	68000600	2	GUARNIZIONE	GARNITURE	DICHTUNG	SEAL	Ø 100		
9	39049200	2	CAPPELOTTO	BOUCHON	ABSCHLUSSKAPPE	CAP NUT			
10	42014003	1	ROTORE	ROTOR	ROTOR	ROTOR	105		
10	42014103	1	ROTORE	ROTOR	ROTOR	ROTOR	115		
10	42014203	1	ROTORE	ROTOR	ROTOR	ROTOR	125		
10	42014303	1	ROTORE	ROTOR	ROTOR	ROTOR	135		
10	42014403	1	ROTORE	ROTOR	ROTOR	ROTOR	145		
10	42068700	1	ROTORE	ROTOR	ROTOR	ROTOR	155		
10	42026903	1	ROTORE	ROTOR	ROTOR	ROTOR	165		
10	42083900	1	ROTORE	ROTOR	ROTOR	ROTOR	175		
11	66000100	1	ANELLO TENUTA	JOINT D'ETANCHEITE	DICHTUNGSRING	JUNT RING	45x65x10		
12	67009700	1	CUSCINETTO	ROULEMENT	LAGER	BEARING	6306		
13	61002300	1	RONDELLA	RONDELLE	SCHEIBE	WASHER	Piana 13x40x4		
14	60020400	1	VITE	VIS	SCHRAUBE	SCREW	TE 12x25 UNI 5739 8,8 ZNT		
15	39014000	1	COPERCHIO	COUVERCLE	DECKEL	COVER			
16	64000200	1	INGRASSATORE	GRAISSEUR	SCHMIERNIPPEL	GREASE FITTING	6x1 dritto		
17	63000300	1	ANELLO ELASTICO	ARRETOIR	SPANNRING	SNAP-RING	Ø 72 I UNI 7437		





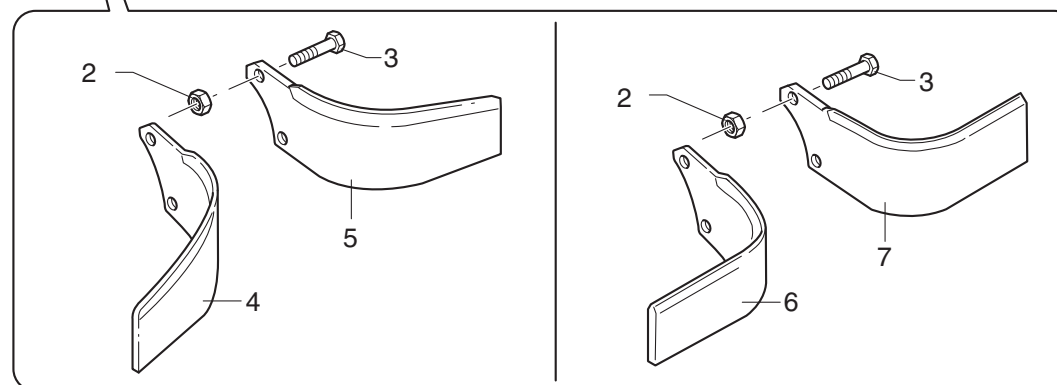
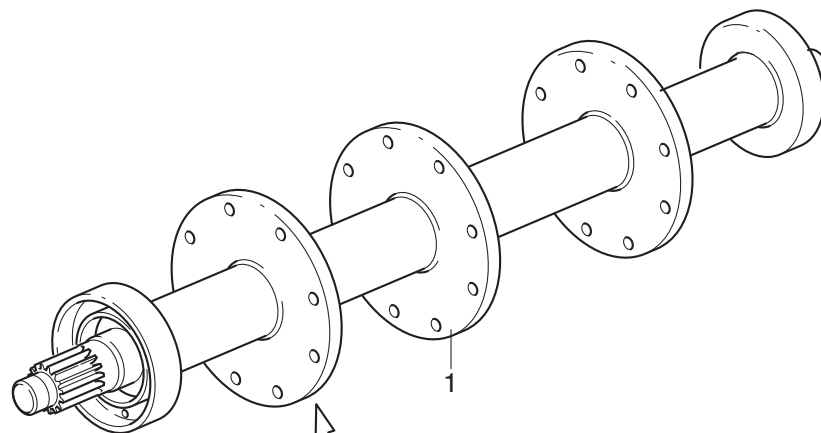



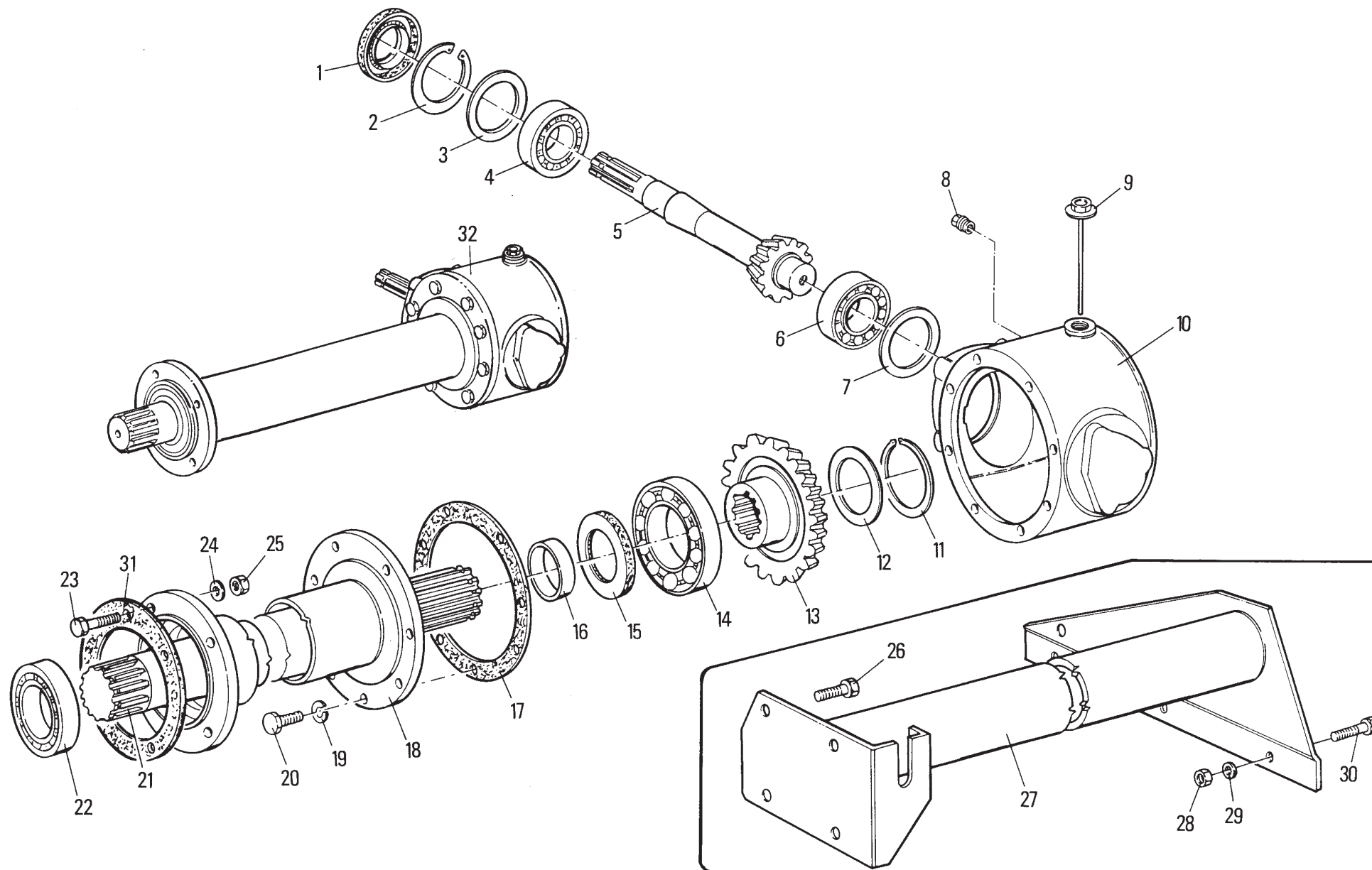

## MURATORI MZ4

TAV. 3.0

POS.	N° CODICE	Q	DESCRIZIONE	DESIGNATION	BENENNUNG	DESCRIPTION	DESIGNAZIONE	Da matr. De nr. serie Vom Seriennr. From serial nr.	Fino matr. Jusqu'au nr. serie Bis Seriennr. Up to serial nr.
1	66001400	1	ANELLO TENUTA	JOINT D'ETANCHEITE	DICHTUNGSRING	JUNT RING	35x80x10		
2	63000200	1	ANELLO ELASTICO	ARRETOIR	SPANNRING	SNAP-RING	Ø80 I UNI 7437		
3	68084300		SPESSORE	EPAISSEUR	DICKE	THICKNESS	47x37x0,5		
4	67002100	1	CUSCINETTO	ROULEMENT	LAGER	BEARING	6307		
5	10000400	1	ALBERO	ARBRE	WELLE	SHAFT	Z 12		
6	67005200	1	CUSCINETTO	ROULEMENT	LAGER	BEARING	30208		
7	68084400		SPESSORE	EPAISSEUR	DICKE	THICKNESS	52x42x1		
8	68008700	1	TAPPO	BOUCHON	STOPFEN	PLUG	3/8 CONICO		
9	68007600	1	TAPPO	BOUCHON	STOPFEN	PLUG			
10	02002800	1	SCATOLA	CARTER	GEHÄUSE	GEARBOX			
11	63000700	1	ANELLO ELASTICO	ARRETOIR	SPANNRING	SNAP-RING	Ø40 E UNI 7435		
12	68084400		SPESSORE	EPAISSEUR	DICKE	THICKNESS	42x52x1		
13	10016700	1	CORONA CONICA	COURONNE CONIQUE	KEGELKRANZ	RING BEVEL	Z 19		
14	67018400	1	CUSCINETTO	ROULEMENT	LAGER	BEARING	6212		
15	66003900	1	ANELLO TENUTA	JOINT D'ETANCHEITE	DICHTUNGSRING	JUNT RING	50x65x8		
16	32045400	1	BOCCOLA	DOUILLE	BUCHSE	BUSHING			
17	80000100	1	GUARNIZIONE	GARNITURE	DICHTUNG	SEAL			
18	40051800	1	CANOTTO	TUBE	ROHR	TUBE	105-115		
18	40051900	1	CANOTTO	TUBE	ROHR	TUBE	125-135		
18	40052000	1	CANOTTO	TUBE	ROHR	TUBE	145		
18	40052100	1	CANOTTO	TUBE	ROHR	TUBE	165-175		
19	61000400	8	RONDELLA	RONDELLE	SCHEIBE	WASHER	DENT INT Ø10 UNI 3704		
20	60017900	8	VITE	VIS	SCHRAUBE	SCREW	TE 10x25 UNI 5739 8,8 ZNT		
21	31024000	1	SEMIASSE	DEMI-ESSIEU	ACHSWELLE	AXLE SHAFT	105-115		
21	31024100	1	SEMIASSE	DEMI-ESSIEU	ACHSWELLE	AXLE SHAFT	125-135		
21	31024200	1	SEMIASSE	DEMI-ESSIEU	ACHSWELLE	AXLE SHAFT	145		

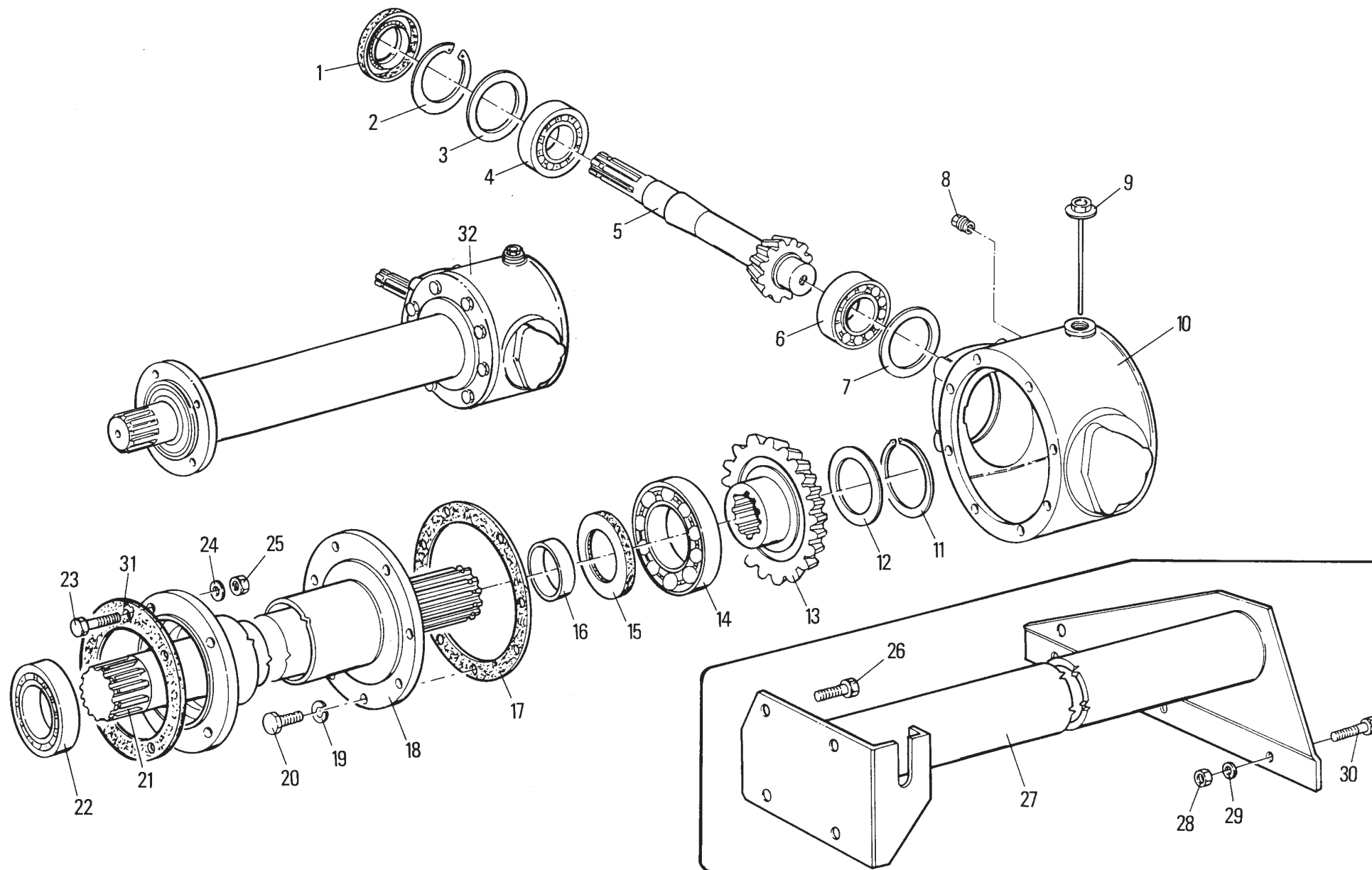



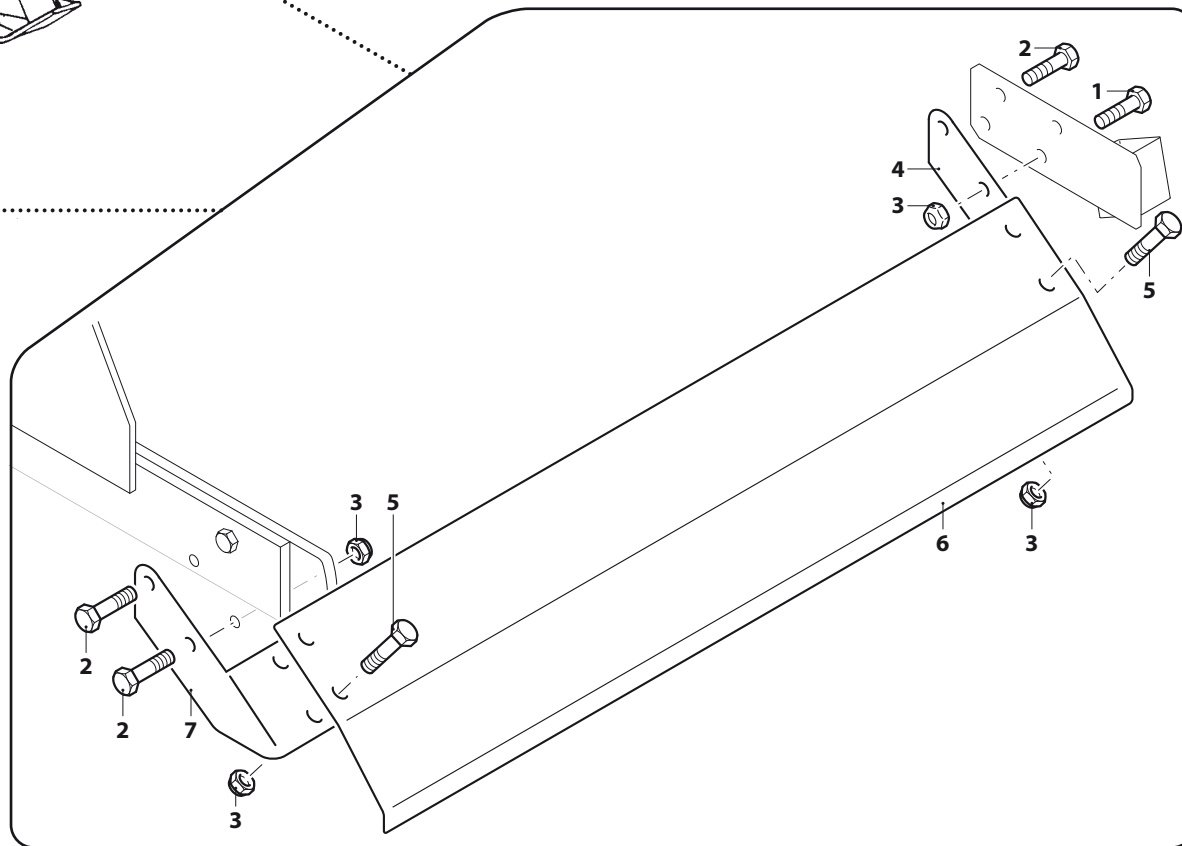
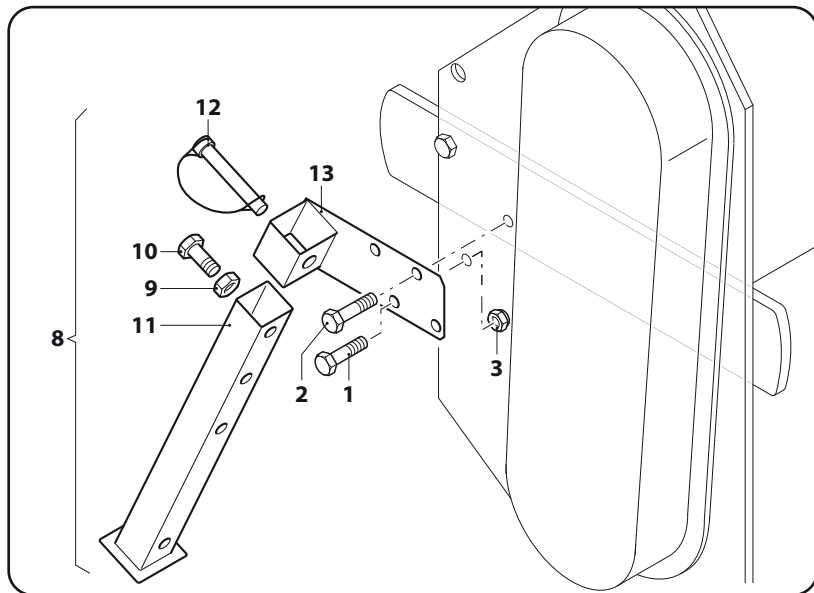
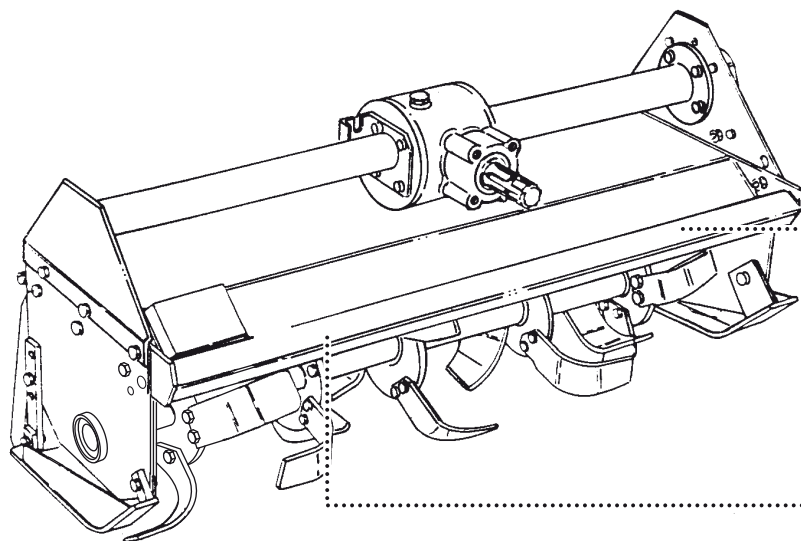









## MURATORI MZ4

## TAV. 5.1

POS.	N° CODICE	Q	DESCRIZIONE	DESIGNATION	BENENNUNG	DESCRIPTION	DESIGNAZIONE	Da matr. De nr. serie Vom Seriennr. From serial nr.	Fino matr Jusqu'au nr. serie Bis Seriennr. Up to serial nr.
1	AB408SFDO	1	ALBERO CARDANICO COMPLETO	ARBRE A JOINTS DE CARDAN	KARDANWELLE	PTO SHAFT		114652	
2	B4080B1	1	SEMIALBERO INTERNO	DEMI-ARBRE INTERIEUR	INNENHALBWELLE	INTERNAL HALF SHAFT		114652	
3	B4080B2	1	SEMIALBERO ESTERNO	DEMI-ARBRE EXTERIEUR	AUSSENHALBWELLE	EXTERNAL HALF SHAFT		114652	
4	B408001	1	SEMIALBERO INTERNO	DEMI-ARBRE INTERIEUR	INNENHALBWELLE	INTERNAL HALF SHAFT		114652	
5	B408002	1	SEMIALBERO ESTERNO	DEMI-ARBRE EXTERIEUR	AUSSENHALBWELLE	EXTERNAL HALF SHAFT		114652	
6	0800403	2	FORCELLA	FOURCHE	GABEL	YOKE		114652	
7	083B04080	1	PROTEZIONE	PROTECTION	SCHUTZ	GUARD		114652	
8	083B040801	1	PROTEZIONE INTERNA	PROTECTION INTERIEURE	INNENSCHUTZ	INTERNAL GUARD		114652	
9	083B040802	1	PROTEZIONE ESTERNA	PROTECTION EXTERIEURE	AUSSENSCHUTZ	EXTERNAL GUARD		114652	
10	0986014047	2	PULSANTE	BOUTON	DRUCKKNOPF	PUSH BOTTON		114652	
11	09840081002	2	INGRASSATORE	GRAISSEUR	SCHMIERNIPPEL	GREASE FITTING		114652	
12	09802027	8	ANELLO ELASTICO	ARRETOIR	SPANNRING	SNAP-RING		114652	
13	08204	2	CROCIERA	CROISILLON	KREUZSTÜCK	SPIDER		114652	
14	08004011	1	FORCELLA	FOURCHE	GABEL	YOKE		114652	
15	098700855	1	SPINA ELASTICA	GOUPILLE ELASTIQUE	SPANNSTIFT	ELASTIC PIN		114652	
16	09881364100	1	TUBO INTERNO	TUBE INTERIEUR	INNENROHR	INTERNAL TUBE		114652	
17	09881433100	1	TUBO ESTERNO	TUBE EXTERIEUR	AUSSENROHR	EXTERNAL TUBE		114652	
18	08004021	1	FORCELLA	FOURCHE	GABEL	YOKE		114652	
19	098700860	1	SPINA ELASTICA	GOUPILLE ELASTIQUE	SPANNSTIFT	ELASTIC PIN		114652	
20	0265240008	1	GHIERA	FRETTE	NUTMUTTER	RING NUT		114652	
21	0256040425	1	CUFFIA	CAPOUCHON	HAUBE	GUARD		114652	
22	0988961B4080	1	TUBO INTERNO	TUBE INTERIEUR	INNENROHR	INTERNAL TUBE		114652	
23	0988966B4080	1	TUBO ESTERNO	TUBE EXTERIEUR	AUSSENROHR	EXTERNAL TUBE		114652	
24	0256040424	1	CUFFIA	CAPOUCHON	HAUBE	GUARD		114652	
25	0265240007	1	GHIERA	FRETTE	NUTMUTTER	RING NUT		114652	





Fino matr. - Jusqu'au nr. serie - Bis Seriennr. - Up to serial nr. 131048

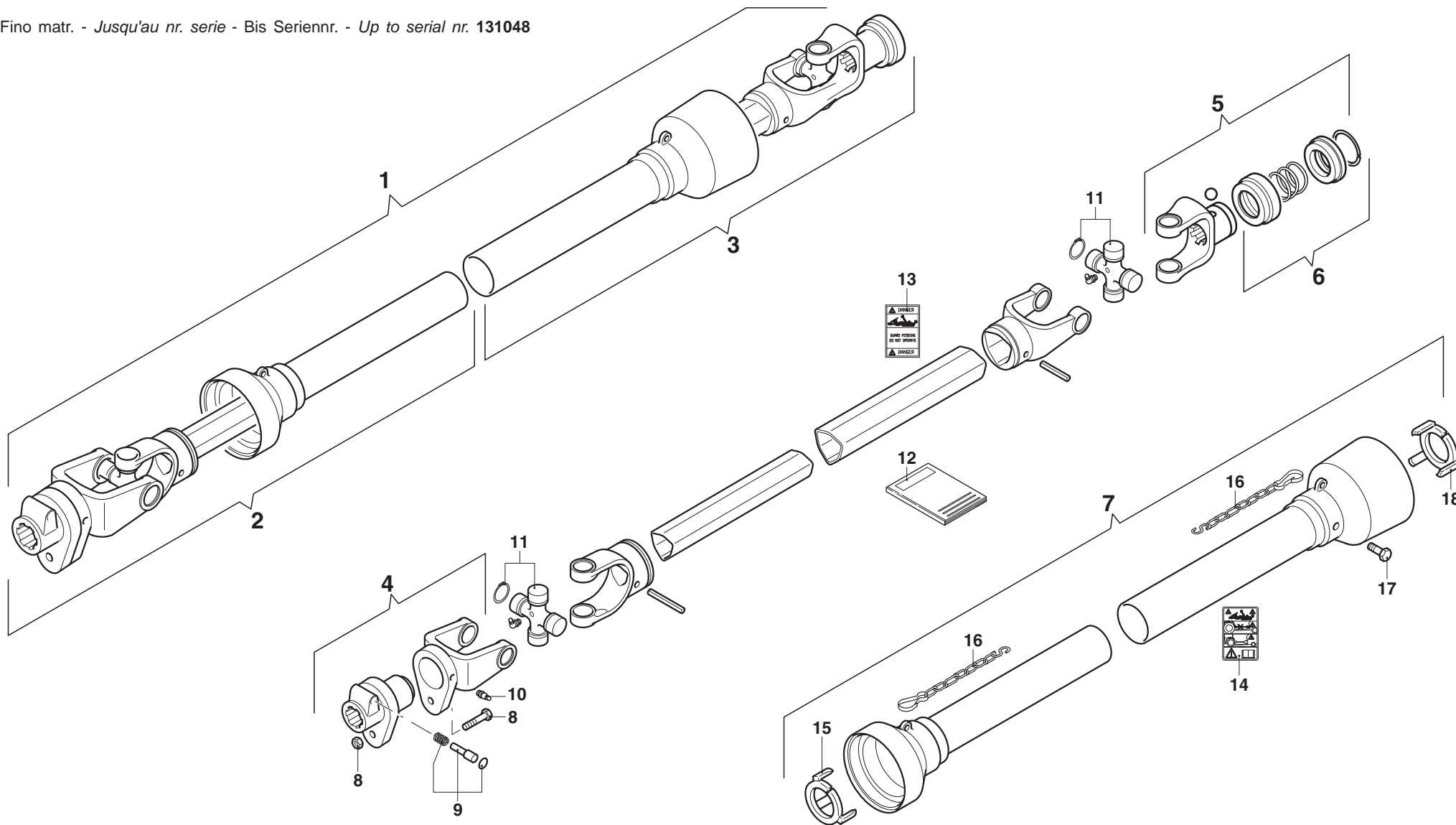



Da matr. - De nr. serie - Vom Seriennr. - From serial nr. 131049

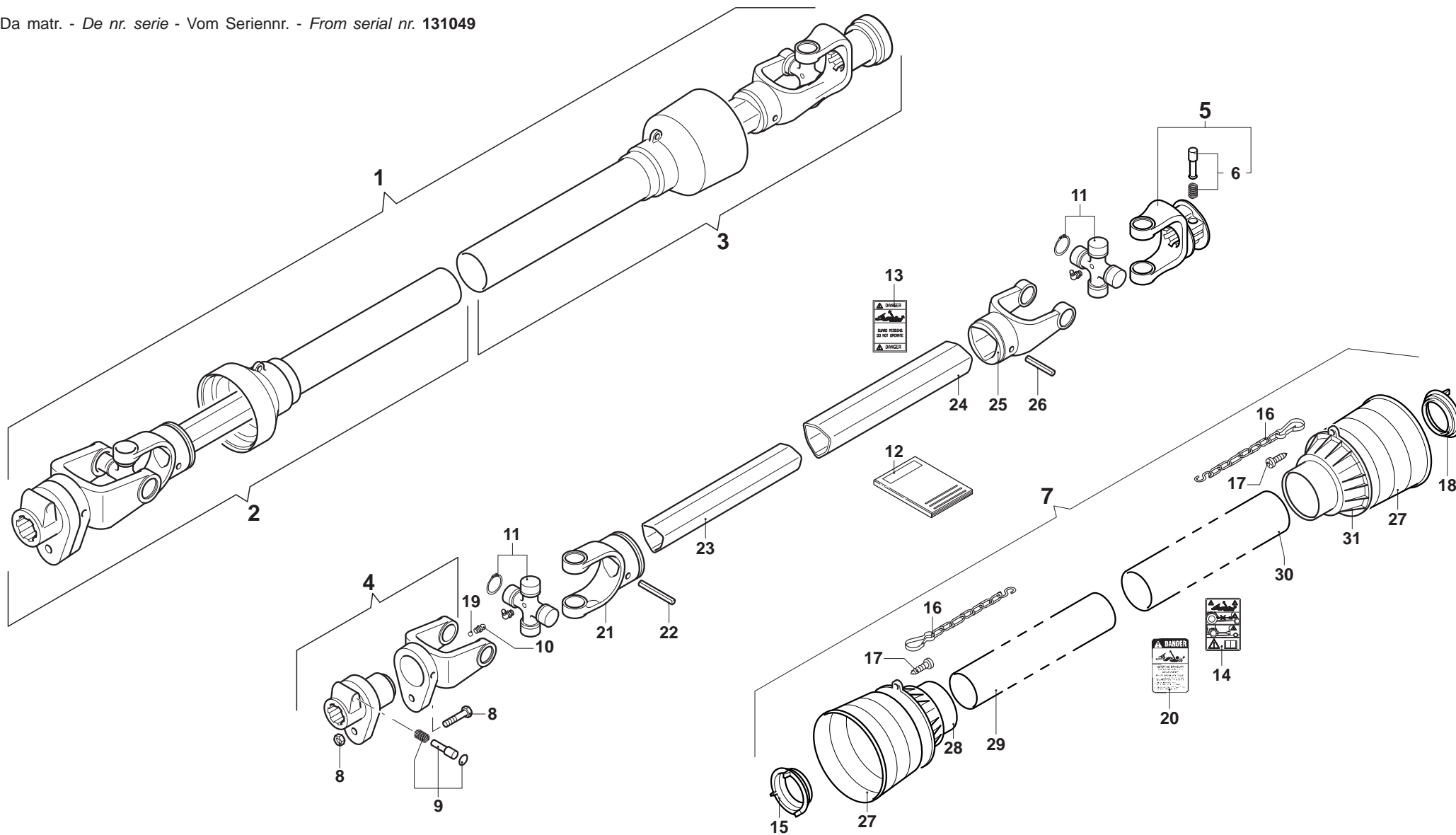

## MURATORI MZ4

## TAV. 6.1

POS.	N° CODICE	Q	DESCRIZIONE	DESIGNATION	BENENNUNG	DESCRIPTION	DESIGNAZIONE	Da matr. De nr. serie Vom Seriennr. From serial nr.	Fino matr. Jusqu'au nr. serie Bis Seriennr. Up to serial nr.
1	AB408FSBDO	1	ALBERO CARDANICO COMPLETO	ARBRE A JOINTS DE CARDAN	KARDANWELLE	PTO SHAFT		131049	
2	B4N058CE1098	1	SEMIALBERO INTERNO	DEMI-ARBRE INTERIEUR	INNENHALBWELLE	INTERNAL HALF SHAFT		131049	
3	B4D058CE2001	1	SEMIALBERO ESTERNO	DEMI-ARBRE EXTERIEUR	AUSSENHALBWELLE	EXTERNAL HALF SHAFT		131049	
4	08804	1	FORCELLA	FOURCHE	GABEL	YOKE		131049	
5	0800403	1	FORCELLA	FOURCHE	GABEL	YOKE		131049	
6	0986014047	1	PULSANTE	BOUTON	DRUCKKNOPF	PUSH BOTTON		131049	
7	083CE04058	1	PROTEZIONE	PROTECTION	SCHUTZ	GUARD		131049	
8	099008050B	1	BULLONE	BOULON	BOLZEN	BOLT		131049	
9	0986014075	1	PULSANTE	BOUTON	DRUCKKNOPF	PUSH BOTTON		131049	
10	0984010150	1	INGRASSATORE	GRAISSEUR	SCHMIERNIPPEL	GREASE FITTING		131049	
11	08204	2	CROCIERA	CROISILLON	KREUZSTÜCK	SPIDER		131049	
12	09872101	1	MANUALE ISTRUZIONI	MANUEL D'UTILISATION ET D'ENTRETIEN	BETRIEBS- UND WARTUNGSANLEITUNG	USE AND MAINTENANCE MANUAL		131049	
13	09872006	1	ETICHETTA	ETIQUETE	ETIKETT	LABEL		131049	
14	09872010	1	ETICHETTA	ETIQUETE	ETIKETT	LABEL		131049	
15	025504C002	1	GHIERA	FRETTE	NUTMUTTER	RING NUT		131049	
16	0252000001	2	CATENA	CHAINE	KETTE	CHAIN		131049	
17	0998052242	6	VITE	VIS	SCHRAUBE	SCREW		131049	
18	025504C001	1	GHIERA	FRETTE	NUTMUTTER	RING NUT		131049	
19	098680104	23	SFERA	BILLE	KUGEL	BALL		131049	
20	09872003	1	ETICHETTA	ETIQUETE	ETIKETT	LABEL		131049	
21	08004011	1	FORCELLA	FOURCHE	GABEL	YOKE		131049	
22	098700855	1	SPINA	GOUPILLE	STIFT	PIN		131049	
23	09881364100	1	TUBO INTERNO	TUBE INTERIEUR	INNENROHR	INTERNAL TUBE		131049	
24	09881433100	1	TUBO ESTERNO	TUBE EXTERIEUR	AUSSENROHR	EXTERNAL TUBE		131049	

Da matr. - De nr. serie - Vom Seriennr. - From serial nr. 131049

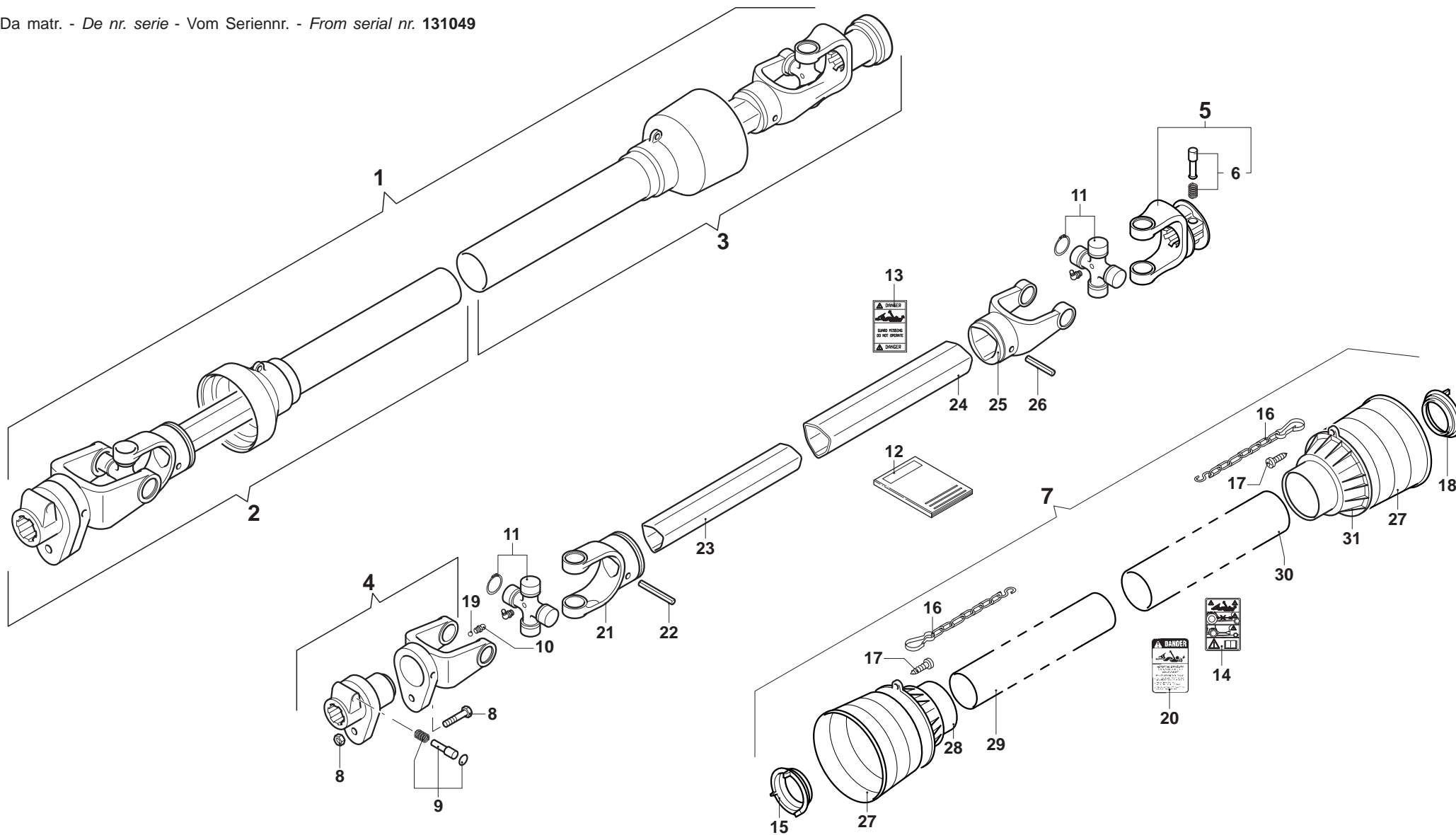



Fino matr. - Jusqu'au nr. serie - Bis Seriennr. - Up to serial nr. 117536

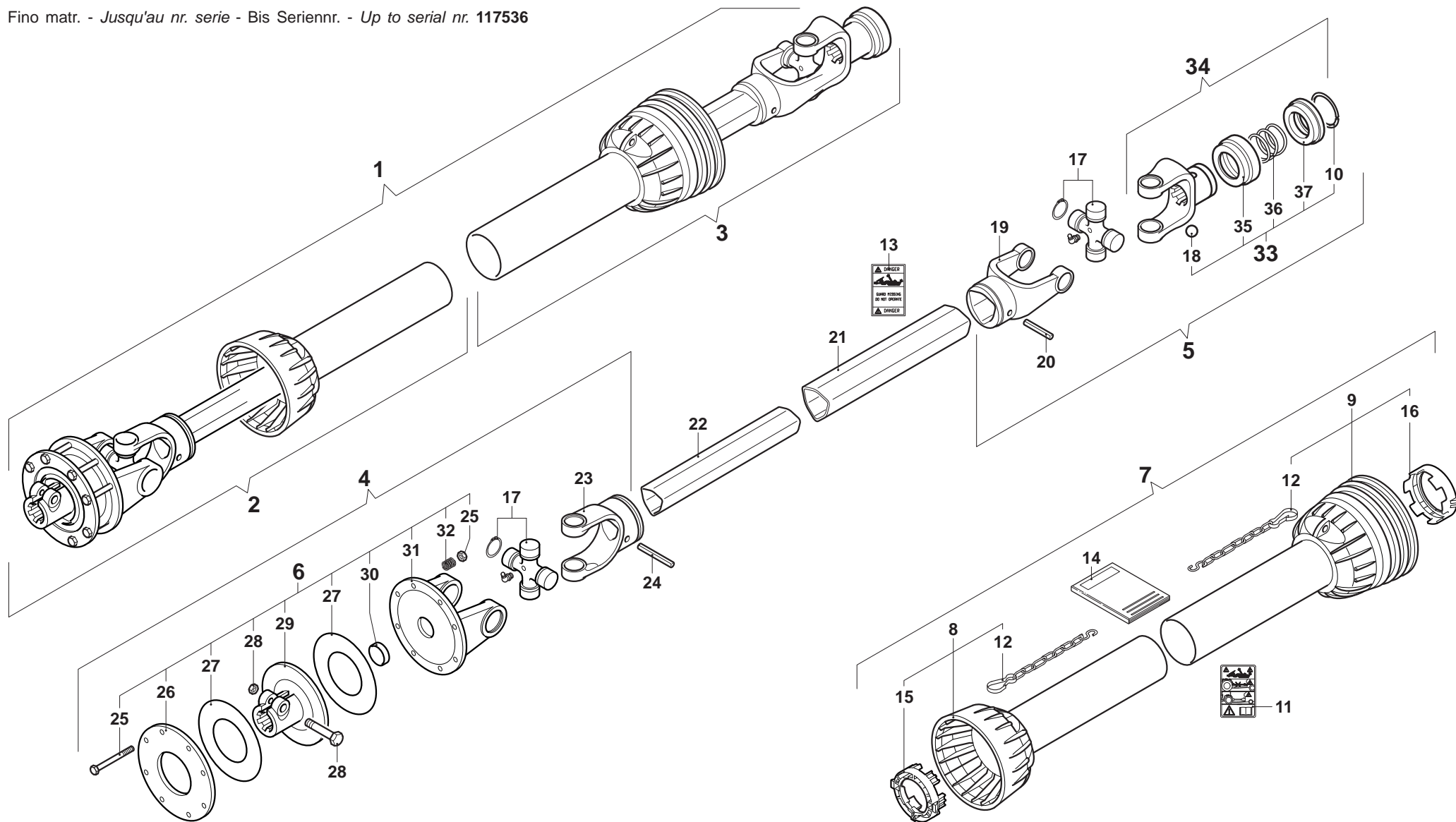

## MURATORI MZ4

## TAV. 7.0

POS.	N° CODICE	Q	DESCRIZIONE	DESIGNATION	BENENNUNG	DESCRIPTION	DESIGNAZIONE	Da matr.	Fino matr.
								De nr. serie Vom Seriennr. From serial nr.	Jusqu'au nr. serie Bis Seriennr. Up to serial nr.
1	AE408FF1	1	ALBERO CARDANICO COMPLETO	ARBRE A JOINTS DE CARDAN	KARDANWELLE	PTO SHAFT		117536	
2	12364010210	1	SEMIALBERO INTERNO	DEMI-ARBRE INTERIEUR	INNENHALBWELLE	INTERNAL HALF SHAFT		117536	
3	12354004310	1	SEMIALBERO ESTERNO	DEMI-ARBRE EXTERIEUR	AUSSENHALBWELLE	EXTERNAL HALF SHAFT		117536	
4	12102489510	1	SEMIALBERO INTERNO	DEMI-ARBRE INTERIEUR	INNENHALBWELLE	INTERNAL HALF SHAFT		117536	
5	12102476010	1	SEMIALBERO ESTERNO	DEMI-ARBRE EXTERIEUR	AUSSENHALBWELLE	EXTERNAL HALF SHAFT		117536	
6	146241001	1	FRIZIONE	EMBRYAGE	KUPPLUNG	CLUTCH		117536	
7	1423400467450	1	PROTEZIONE	PROTECTION	SCHUTZ	GUARD		117536	
8	1423470227450	1	PROTEZIONE INTERNA	PROTECTION INTERIEURE	INNENSCHUTZ	INTERNAL GUARD		117536	
9	1423460027450	1	PROTEZIONE ESTERNA	PROTECTION EXTERIEURE	AUSSENSCHUTZ	EXTERNAL GUARD		117536	
10	190000451	1	ANELLO	BAGUE	RING	RING		117536	
11	190000099	1	ETICHETTA	ETIQUETE	ETIKETT	LABEL		117536	
12	180016636	2	CATENA	CHAINE	KETTE	CHAIN		117536	
13	190000098	1	ETICHETTA	ETIQUETE	ETIKETT	LABEL		117536	
14	190000692	1	MANUALE ISTRUZIONI	MANUEL D'UTILISATION ET D'ENTRETIEN	BETRIEBS- UND WARTUNGSANLEITUNG	USE AND MAINTENANCE MANUAL		117536	
15	180014505	1	GHIERA	FRETTE	NUTMUTTER	RING NUT		117536	
16	180014506	1	GHIERA	FRETTE	NUTMUTTER	RING NUT		117536	
17	180014130	2	CROCIERA	CROISILLON	KREUZSTÜCK	SPIDER		117536	
18	190000078	3	SFERA	BILLE	KUGEL	BALL		117536	
19	151014006	1	FORCELLA	FOURCHE	GABEL	YOKE		117536	
20	190000014	1	SPINA	GOUPILLE	STIFT	PIN		117536	
21	1521402800730	1	TUBO ESTERNO	TUBE EXTERIEUR	AUSSENROHR	EXTERNAL TUBE		117536	
22	153140188	1	TUBO INTERNO	TUBE INTERIEUR	INNENROHR	INTERNAL TUBE		117536	
23	151014007	1	FORCELLA	FOURCHE	GABEL	YOKE		117536	
24	190000012	1	SPINA	GOUPILLE	STIFT	PIN		117536	

Fino matr. - Jusqu'au nr. serie - Bis Seriennr. - Up to serial nr. 117536

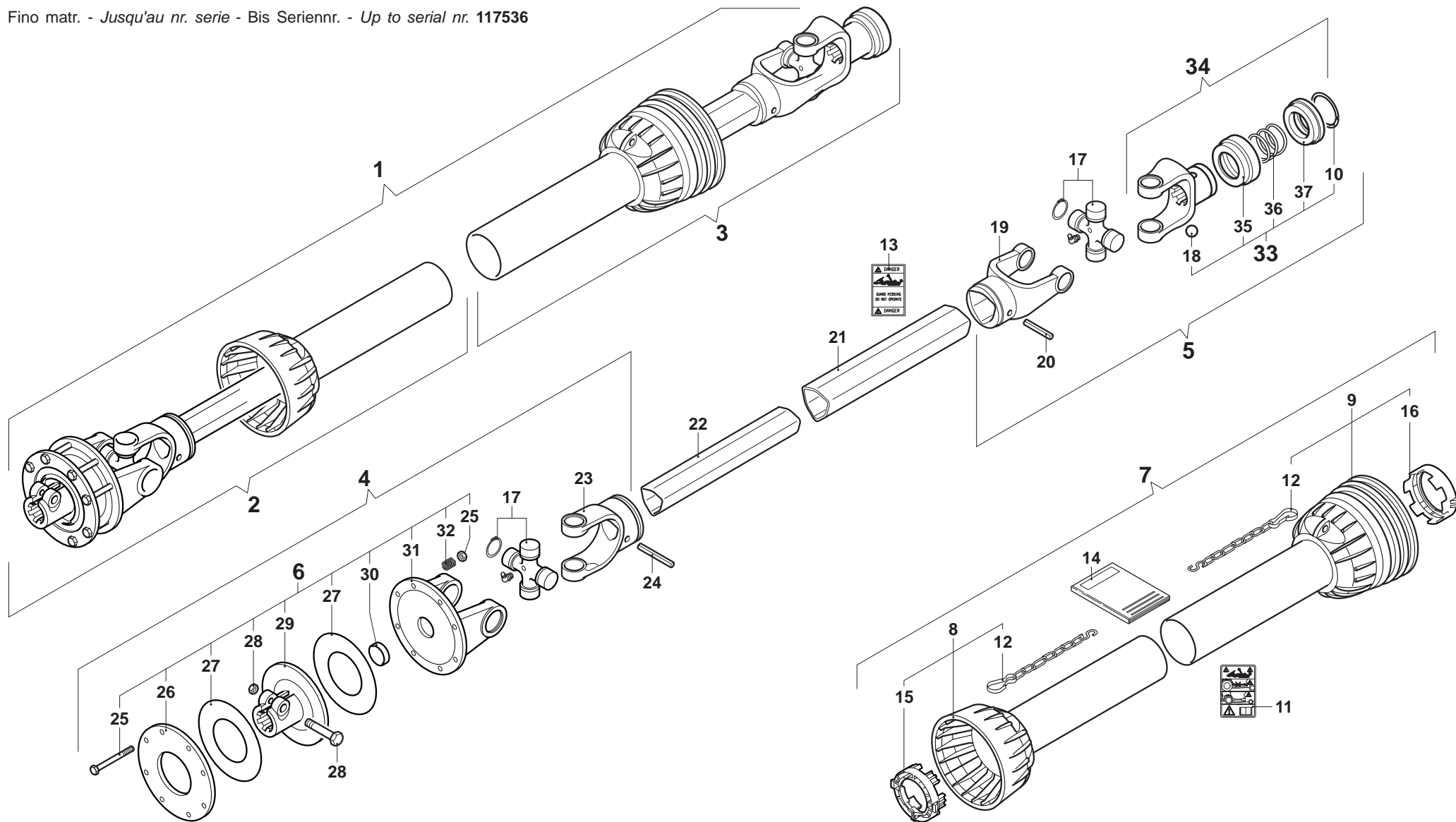



Da matr. - De nr. serie - Vom Seriennr. - From serial nr. 117537

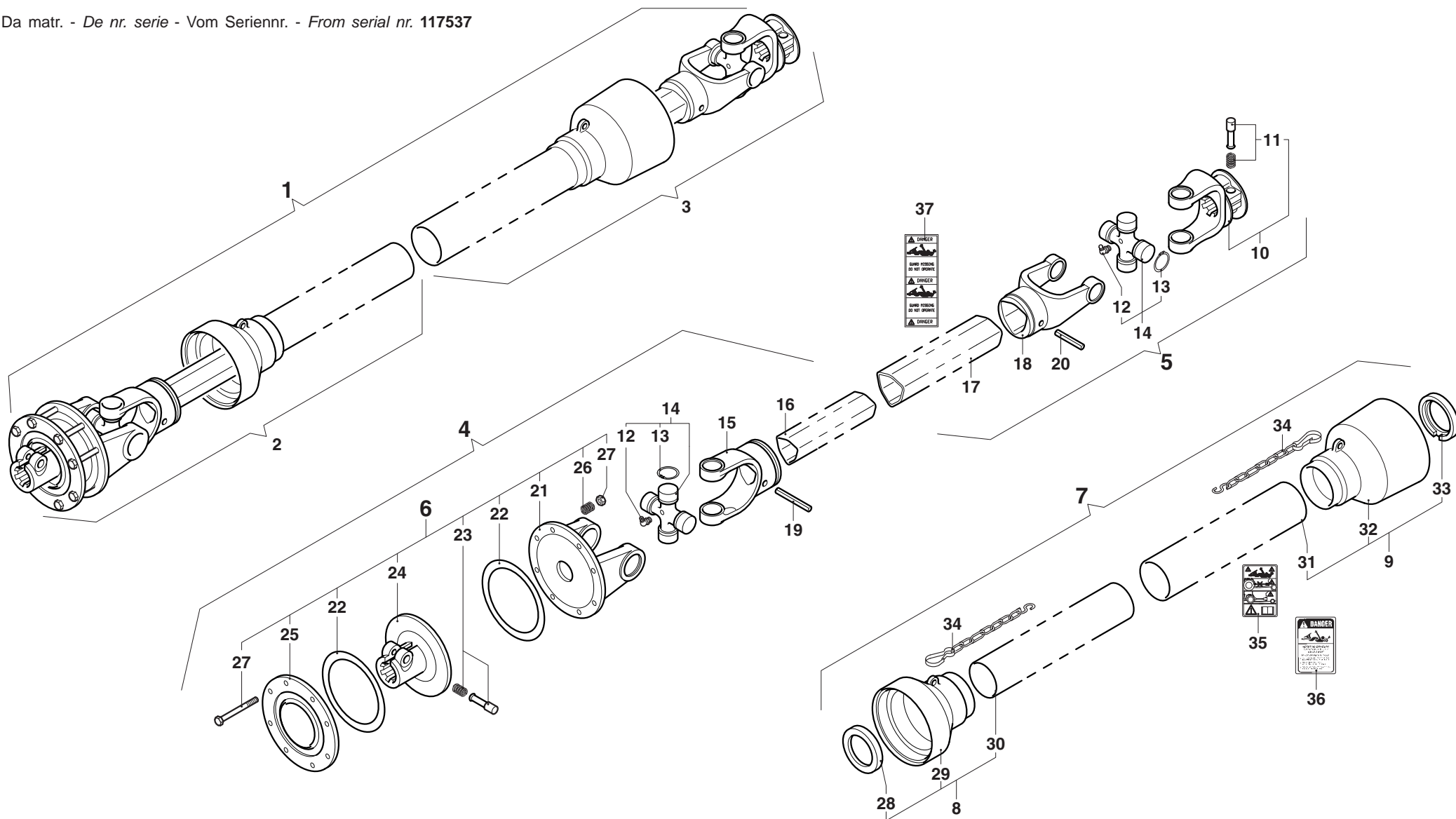

## MURATORI MZ4

## TAV. 7.1

POS.	N° CODICE	Q	DESCRIZIONE	DESIGNATION	BENENNUNG	DESCRIPTION	DESIGNAZIONE	Da matr. De nr. serie Vom Seriennr. From serial nr.	Fino matr. Jusqu'au nr. serie Bis Seriennr. Up to serial nr.
1	AB408FF1DO	1	ALBERO CARDANICO COMPLETO	ARBRE A JOINTS DE CARDAN	KARDANWELLE	PTO SHAFT		117537	
2	B408001243	1	SEMIALBERO INTERNO	DEMI-ARBRE INTERIEUR	INNENHALBWELLE	INTERNAL HALF SHAFT		117537	
3	B408002	1	SEMIALBERO ESTERNO	DEMI-ARBRE EXTERIEUR	AUSSENHALBWELLE	EXTERNAL HALF SHAFT		117537	
4	B50851243	1	SEMIALBERO INTERNO	DEMI-ARBRE INTERIEUR	INNENHALBWELLE	INTERNAL HALF SHAFT		117537	
5	B50852S60	1	SEMIALBERO ESTERNO	DEMI-ARBRE EXTERIEUR	AUSSENHALBWELLE	EXTERNAL HALF SHAFT		117537	
6	086105	1	FRIZIONE	EMBRYAGE	KUPPLUNG	CLUTCH		117537	
7	083B04080	1	PROTEZIONE	PROTECTION	SCHUTZ	GUARD		117537	
8	083B040801	1	PROTEZIONE INTERNA	PROTECTION INTERIEURE	INNENSCHUTZ	INTERNAL GUARD		117537	
9	083B040802	1	PROTEZIONE ESTERNA	PROTECTION EXTERIEURE	AUSSENSCHUTZ	EXTERNAL GUARD		117537	
10	0800503S60	1	FORCELLA	FOURCHE	GABEL	YOKE		117537	
11	0435000300	1	PULSANTE	BOUTON	DRUCKKNOPF	PUSH BOTTON		117537	
12	09840081002	2	INGRASSATORE	GRAISSEUR	SCHMIERNIPPEL	GREASE FITTING		117537	
13	09802030	8	ANELLO ELASTICO	ARRETOIR	SPANNRING	SNAP-RING		117537	
14	08204	2	CROCIERA	CROISILLON	KREUZSTÜCK	SPIDER		117537	
15	08005011	1	FORCELLA	FOURCHE	GABEL	YOKE		117537	
16	09881364100	1	TUBO INTERNO	TUBE INTERIEUR	INNENROHR	INTERNAL TUBE		117537	
17	09881433100	1	TUBO ESTERNO	TUBE EXTERIEUR	AUSSENROHR	EXTERNAL TUBE		117537	
18	08005021	1	FORCELLA	FOURCHE	GABEL	YOKE		117537	
19	098700865	1	SPINA ELASTICA	GOUPILLE ELASTIQUE	SPANNSTIFT	ELASTIC PIN		117537	
20	098700870	1	SPINA ELASTICA	GOUPILLE ELASTIQUE	SPANNSTIFT	ELASTIC PIN		117537	
21	086910105	1	FORCELLA	FOURCHE	GABEL	YOKE		117537	
22	09833140	2	DISCO	DISQUE	SCHEIBE	DISC		117537	
23	0986014075	1	PULSANTE	BOUTON	DRUCKKNOPF	PUSH BOTTON		117537	
24	0869107A60	1	MOZZO	MOYEU	NABE	HUB		117537	
25	0869112	1	DISCO	DISQUE	SCHEIBE	DISC		117537	

Da matr. - De nr. serie - Vom Seriennr. - From serial nr. 117537

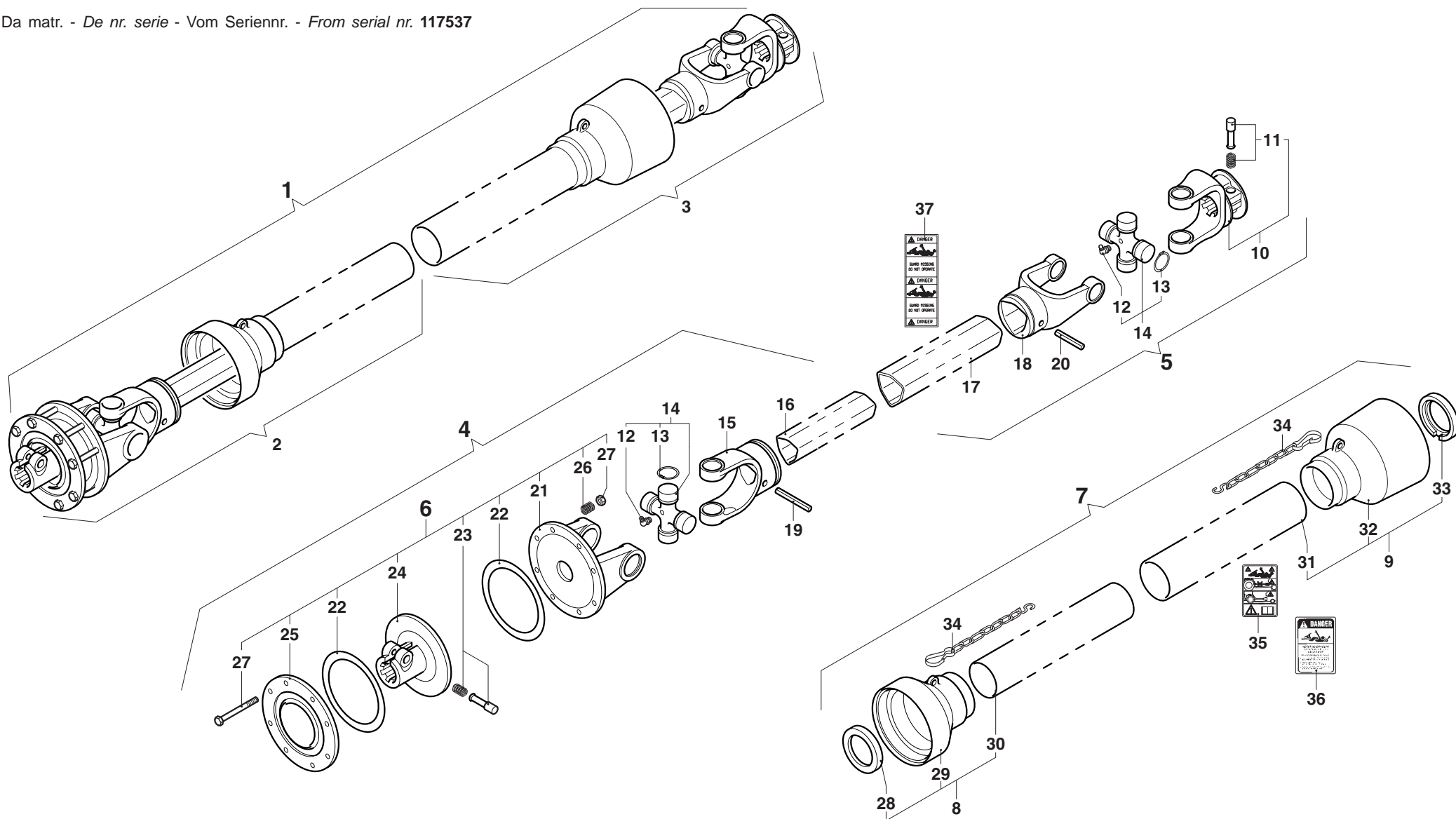









**MURATORI S.p.A.**

Via Pavarello, 21 - 41051 Castelnuovo Rangone (MO) Italy - Tel. 059.5330611 Fax 059.537259

**[www.muratoriequip.it](http://www.muratoriequip.it)** *info@muratoriequip.it*

**Capitale sociale Euro 480.000 interamente versato**

**Registro Imprese di Modena**

**Codice fiscale e numero d'iscrizione: 00708860366**