



MURATORI

**TIPO-TYPE-TYP
ME1**

CATALOGO RICAMBI
Catalogue Pièces Detachées
Ersatzteilkatalog
Spare Parts Catalogue
Catálogo Recambios

EDIZIONE 04/2016

Per ordinare parti di ricambio specificare:

- tipo e matricola della macchina (apposti sulla macchina o sui documenti di acquisto);
- numero del riferimento del pezzo nel disegno (Pos.), numero della tavola (Tav.) e numero di codice

N.B.: le indicazioni destro o sinistro vengono date guardando la macchina da dietro.

Pour les commandes de pièces de rechange veuillez spécifier:

- type et numéro de serie de la machine (indiqués sur la machine et sur le bon d'achat);
- numéro de référence du pièce sur le plan (Pos.), numéro du plan (Tav.) et numéro de code (codice)

N.B.: les indications droite ou gauche sont données en regardant la machine par derrière.

Zum Bestellen von Ersatzteilen folgendes angeben:

- Typ und Serien-Nr. der Maschine (zu finden auf der Maschine oder der Einkaufspapieren);
- Bezug-Nr. des Ersatzteils auf der Zeichnung (Pos.), Zeichnungsnummer (Tav.) und Kodenummer (codice)

N.B.: Die Angaben rechts und links verstehen sich so, dass man hinter der Maschine steht.

When ordering spare parts specify:

- machine type and serial number (found on the machine or on the purchasing documents);
- reference number of the part on the relative drawing (Pos.), number of the drawing (Tav.) and part number (codice)

N.B.: right-hand or left-hand indications are made by viewing the machine from the rear.

TAV. 1.0
GRUPPO TELAIO
ENSEMBLE CHASSIS
SATZ FÜR RAHMEN
KIT FOR FRAME

TAV. 2.0
GRUPPO ROTORI
ENSEMBLE ROTORS
SATZ FÜR ROTOREN
KIT FOR ROTORS

TAV. 3.0
GRUPPO RIDUTTORE A 1 VELOCITA'
ENSEMBLE BOITIER MONOVITESSE
SATZ FÜR EINGANGGETRIEBE
KIT FOR ONE-SPEED GEAR BOX

TAV. 4.0
GRUPPO RULLO POSTERIORE
ENSEMBLE ROULEAU ARRIERE
SATZ HINTERE WALZE
KIT REAR ROLLER

TAV. 5.0
BARRA LIVELLATRICE ANTERIORE
BARRE NIVELLEUSE AVANT
VORDERE PLANIERSCHIENE
FRONT LEVELLING BAR

TAV. 6.0
REGOLAZIONE A VITE RULLO GABBIA
REGLAGE DU ROULEAU A CAGE
REGELUNG DER STABWALZE
CAGE ROLLER ADJUSTMENT

TAV. 6.1
REGOLAZIONE A VITE RULLO COCLEA
REGLAGE DU ROULEAU EN TOLE STRIE
REGELUNG DER GITTERWALZE
MESH ROLLER ADJUSTMENT

TAV. 7.0
PROTEZIONI ANTINFORTUNISTICHE "CE"
PROTECTIONS "CE"
UNFALLSCHUTZVORRICHTUNGEN "CE"
SAFETY GUARDS "CE"

TAV. 7.1
BANDELLE LATERALI SPECIALI
PROTECTION HARDOX ACIER
SCHUTZ HARDOX STAHL
SIDE PLATES HARDOX STEEL

TAV. 8.0 (ME1 90-110)
ALBERO CARDANICO COMPLETO
ARBRE A JOINTS DE CARDAN
KARDANWELLE
PTO SHAFT

TAV. 8.1
ALBERO CARDANICO COMPLETO
ARBRE A JOINTS DE CARDAN
KARDANWELLE
PTO SHAFT

TAV. 9.0 (ME1 130-170)
ALBERO CARDANICO COMPLETO
ARBRE A JOINTS DE CARDAN
KARDANWELLE
PTO SHAFT

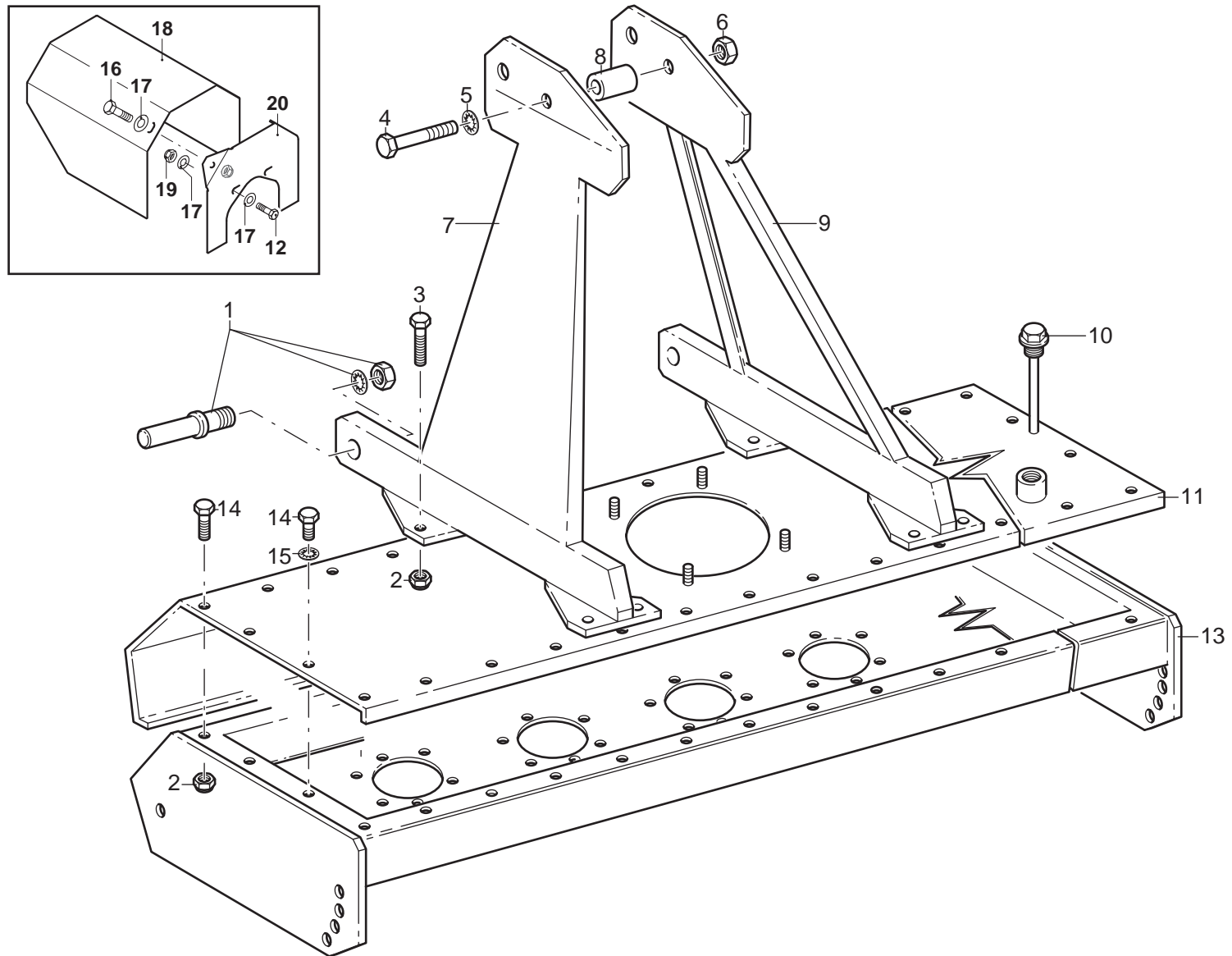

MURATORI ME1

TAV. 1.0

POS.	N°	CODICE Q	DESCRIZIONE	DESIGNATION	BENENNUNG	DESCRIPTION	DESIGNAZIONE	Da matr.	Fino matr
								De nr. serie Vom Seriennr. From serial nr.	Jusqu'au nr. serie Bis Seriennr. Up to serial nr.
1	68062500	2	PERNO	PIVOT	BOLZEN	PIN			
2	62010400		DADO	ECROU	MUTTER	NUT	M 10x1,5 AUTOBLOCC.		
3	60023500	8	VITE	VIS	SCHRAUBE	SCREW	TE M 10x35 UNI 5739 8.8 ZNT		
4	60010400	1	VITE	VIS	SCHRAUBE	SCREW	TE 12x75 UNI 5737		
5	61000500	1	RONDELLA	RONDELLE	SCHEIBE	WASHER	DENT. INT. Ø 12 UNI 3704		
6	62000600	1	DADO	ECROU	MUTTER	NUT	M 12x1,75 AUTOBLOCC.		
7	40063400	1	ARCATA SX	ARCADE	ARKADE	ARCADE			
8	32055800	1	DISTANZIALE	ENTRETOISE	DISTANZSTÜCK	SPACER			
9	40063500	1	ARCATA DX	ARCADE	ARKADE	ARCADE			
10	68078400	1	TAPPO	BOUCHON	STOPFEN	PLUG			
11	40063601	1	COPERCHIO	COUVERCLE	DECKEL	COVER	90		
11	40063701	1	COPERCHIO	COUVERCLE	DECKEL	COVER	110		
11	40063801	1	COPERCHIO	COUVERCLE	DECKEL	COVER	130		
11	40063901	1	COPERCHIO	COUVERCLE	DECKEL	COVER	150		
12	60022800	2	VITE	VIS	SCHRAUBE	SCREW	TE 8x20 UNI 5739		
13	40103001	1	CASSA	CAISSE	WANNE	GEARCASE	90		
13	40103101	1	CASSA	CAISSE	WANNE	GEARCASE	110		
13	40103201	1	CASSA	CAISSE	WANNE	GEARCASE	130		
13	40103301	1	CASSA	CAISSE	WANNE	GEARCASE	150		
14	60017900		VITE	VIS	SCHRAUBE	SCREW	TE M 10x25 UNI 5739 8.8 ZNT		
15	61000400	4	RONDELLA	RONDELLE	SCHEIBE	WASHER	DENT. INT. Ø 10 UNI 3704		
16	60015100	2	VITE	VIS	SCHRAUBE	SCREW	TE 8x16 UNI 5739		
17	61006200	6	RONDELLA	RONDELLE	SCHEIBE	WASHER	PIANA Ø 9		
18	39209000	1	PROTEZIONE	PROTECTION	SCHUTZ	GUARD			
19	62010200	2	DADO	ECROU	MUTTER	NUT	M 8x1,25 AUTOBLOCC.		
20	40304100	1	SUPPORTO	SUPPORT	HALTERUNG	SUPPORT			

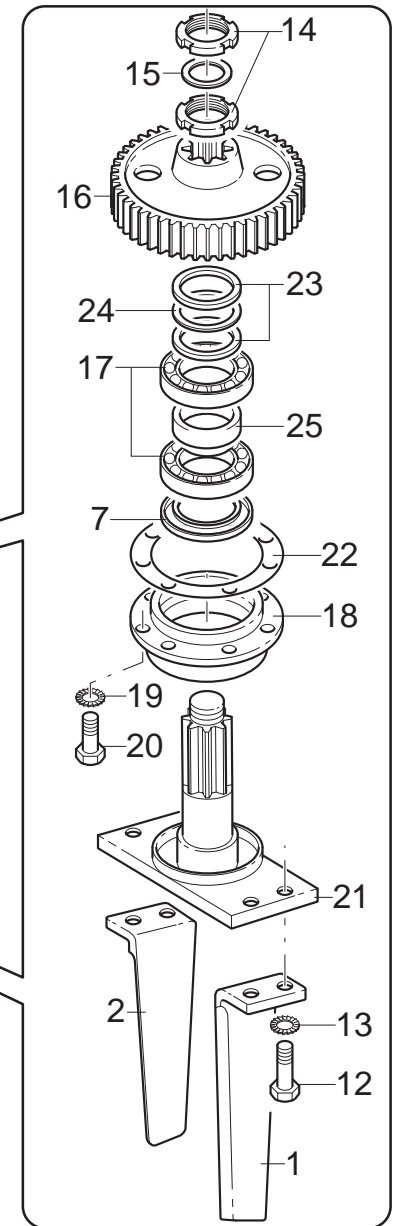
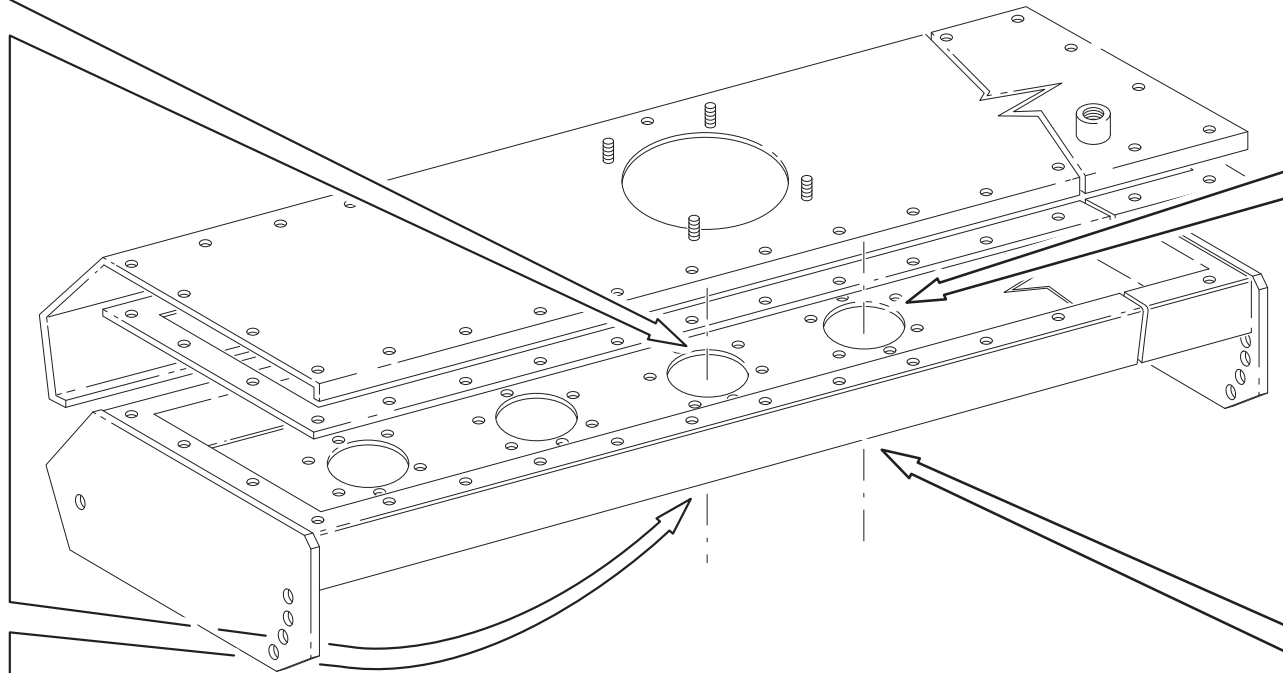
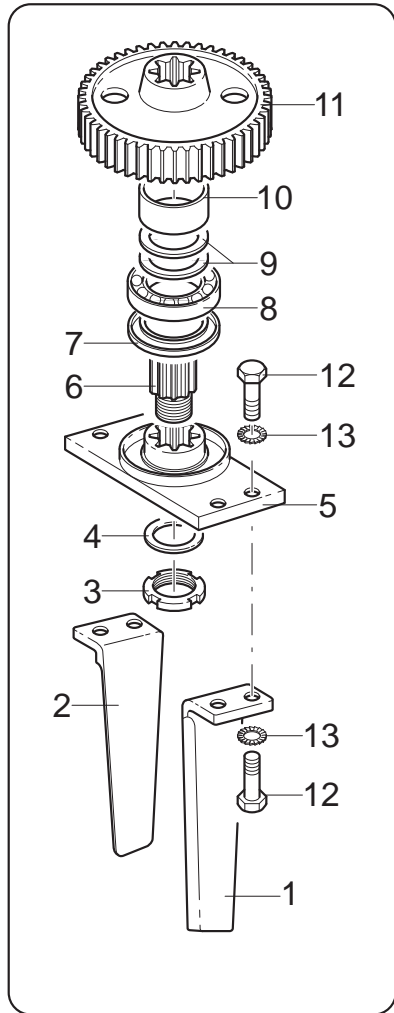

MURATORI ME1

TAV. 2.0

POS.	N°	CODICE Q	DESCRIZIONE	DESIGNATION	BENENNUNG	DESCRIPTION	DESIGNAZIONE	Da matr.	Fino matr
								De nr. serie Vom Seriennr. From serial nr.	Jusqu'au nr. serie Bis Seriennr. Up to serial nr.
1		12007100	LAMA SX	LAME DE COUPE	SCHNEIDKANTE	BLADE			
2		12007000	LAMA DX	LAME DE COUPE	SCHNEIDKANTE	BLADE			
3		62007800	1 DADO	ECROU	MUTTER	NUT	M 30x2 UNI 5594		
4		61008900	1 RONDELLA	RONDELLE	SCHEIBE	WASHER			
5		40126700	1 ROTORE CENTRALE	ROTOR	ROTOR	ROTOR			
6		31029201	1 ALBERO	ARBRE	WELLE	SHAFT			
7		66010700	ANELLO TENUTA	JOINT D'ETANCHEITE	DICHTUNGSRING	JUNT RING	50 x 80 x 10		
8		67004400	CUSCINETTO	ROULEMENT	LAGER	BEARING	6208		
9		68008200	2 SPESSORE	EPAISSEUR	DISTANZRING	SPACER			
10		32055901	1 DISTANZIALE	ENTRETOISE	DISTANZSTÜCK	SPACER		50964	
10		32055902	1 DISTANZIALE	ENTRETOISE	DISTANZSTÜCK	SPACER	50965		
11		10018900	1 INGRANAGGIO CENTRALE	PIGNON	ZAHNRAD	GEAR			
12		60023000	VITE	VIS	SPINDEL	SCREW	TE M 12x30 UNI 5739 8.8 ZNT		
13		61000500	RONDELLA	RONDELLE	SCHEIBE	WASHER	DENT. INT. Ø 12 UNI 3704		
14		62008100	GHIERA	FRETTE	NUTMUTTER	RING NUT	M 30x1,5 Km		
15		61007600	RONDELLA	RONDELLE	SCHEIBE	WASHER			
16		10018800	INGRANAGGIO LATERALE	PIGNON	ZAHNRAD	GEAR			
17		67005200	CUSCINETTO	ROULEMENT	LAGER	BEARING	30208		
18		10027700	SUPPORTO	SUPPORT	HALTERUNG	SUPPORT			
19		61000400	RONDELLA	RONDELLE	SCHEIBE	WASHER	DENT. INT. Ø 10 UNI 3704		
20		60021300	VITE	VIS	SCHRAUBE	SCREW	TE M 10x30 UNI 5739 8.8 ZNT		
21		40103400	ROTORE LATERALE	ROTOR	ROTOR	ROTOR			
22		80012600	GUARNIZIONE	GARNITURE	DICHTUNG	SEAL			
23		68017000	2 SPESSORE	EPAISSEUR	DISTANZRING	SPACER	50x40x0,2		
24		68008200	1 SPESSORE	EPAISSEUR	DISTANZRING	SPACER	50x40x1		
25		32164100	1 DISTANZIALE	ENTRETOISE	DISTANZSTÜCK	SPACER			

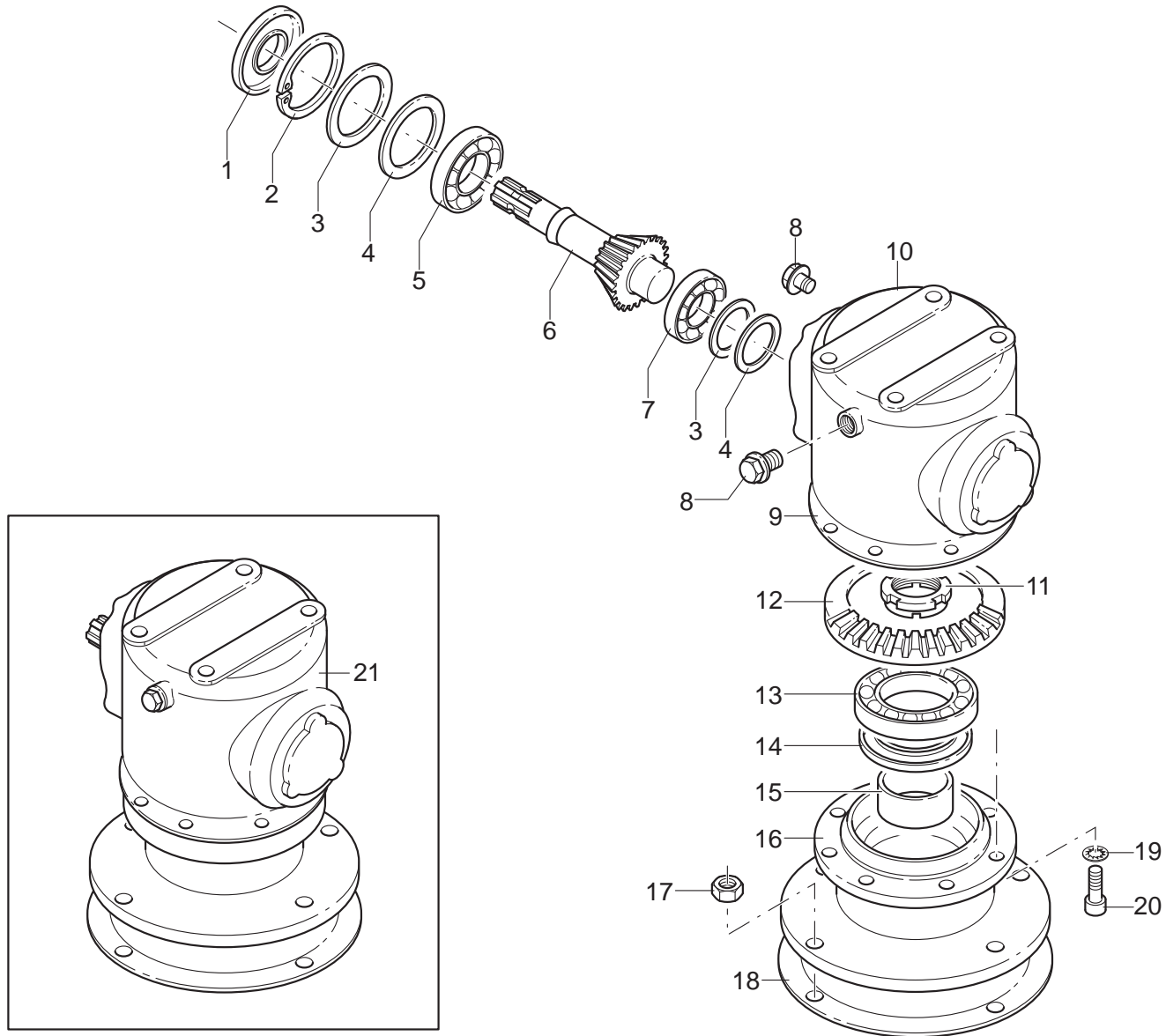

MURATORI ME1

TAV. 3.0

POS.	N°	CODICE Q	DESCRIZIONE	DESIGNATION	BENENNUNG	DESCRIPTION	DESIGNAZIONE	Da matr.	Fino matr
								De nr. serie Vom Seriennr. From serial nr.	Jusqu'au nr. serie Bis Seriennr. Up to serial nr.
1	66001400	1	ANELLO TENUTA	JOINT D'ETANCHEITE	DICHTUNGSRING	JUNT RING	35 x 80 x 10	27255	
1	66001500	1	ANELLO TENUTA	JOINT D'ETANCHEITE	DICHTUNGSRING	JUNT RING	35 x 72 x 10		27254
2	63000200	1	ANELLO ELASTICO	ARRETOIR	SPANNRING	SNAP-RING	Ø 80 I UNI 7437	27255	
2	63000300	1	ANELLO ELASTICO	ARRETOIR	SPANNRING	SNAP-RING	Ø 72 I UNI 7437		27254
3	68084300		SPESSORE	EPAISSEUR	DISTANZRING	SPACER	47 x 37 x 0,5	27255	
4	68010300		SPESSORE	EPAISSEUR	DISTANZRING	SPACER	45 x 35 x 0,5	27255	
5	67002100	1	CUSCINETTO	ROULEMENT	LAGER	BEARING	6307	27255	
5	67003700	1	CUSCINETTO	ROULEMENT	LAGER	BEARING	6207		27254
6	10000400	1	ALBERO	ARBRE	WELLE	SHAFT		27255	
6	10029200	1	ALBERO	ARBRE	WELLE	SHAFT			27254
7	67004800	1	CUSCINETTO	ROULEMENT	LAGER	BEARING	6209		27254
7	67005200	1	CUSCINETTO	ROULEMENT	LAGER	BEARING	30208	27255	
8	68008700	2	TAPPO	BOUCHON	STOPFEN	PLUG			
9	80000100	1	GUARNIZIONE	GARNITURE	DICHTUNG	SEAL		27255	
9	80008500	1	GUARNIZIONE	GARNITURE	DICHTUNG	SEAL			27254
10	02002800	1	SCATOLA	CARTER	GEHÄUSE	GEARBOX		27255	
10	01010100	1	SCATOLA	CARTER	GEHÄUSE	GEARBOX			27254
11	62006500	1	GHIERA	FRETTE	NUTMUTTER	RING NUT	M 35 x 1,5		
12	10005600	1	CORONA CONICA	COURONNE CONIQUE	KEGELKRANZ	RING BEVEL	Z 23 M 5		27254
12	10016700	1	CORONA CONICA	COURONNE CONIQUE	KEGELKRANZ	RING BEVEL	Z 19 M 6,5	27255	
13	67000200	1	CUSCINETTO	ROULEMENT	LAGER	BEARING	6212	27255	
13	67001900	1	CUSCINETTO	ROULEMENT	LAGER	BEARING	6308		27254
14	66000800	1	ANELLO TENUTA	JOINT D'ETANCHEITE	DICHTUNGSRING	JUNT RING	50 x 80 x 10		27254
14	66003900	1	ANELLO TENUTA	JOINT D'ETANCHEITE	DICHTUNGSRING	JUNT RING	50 x 65 x 8	27255	
15	32045400	1	BOCCOLA	DOUILLE	BÜCHSE	BUSHING		27255	
16	01010200	1	FLANGIA	BRIDE	FLANSCH	FLANGE			27254

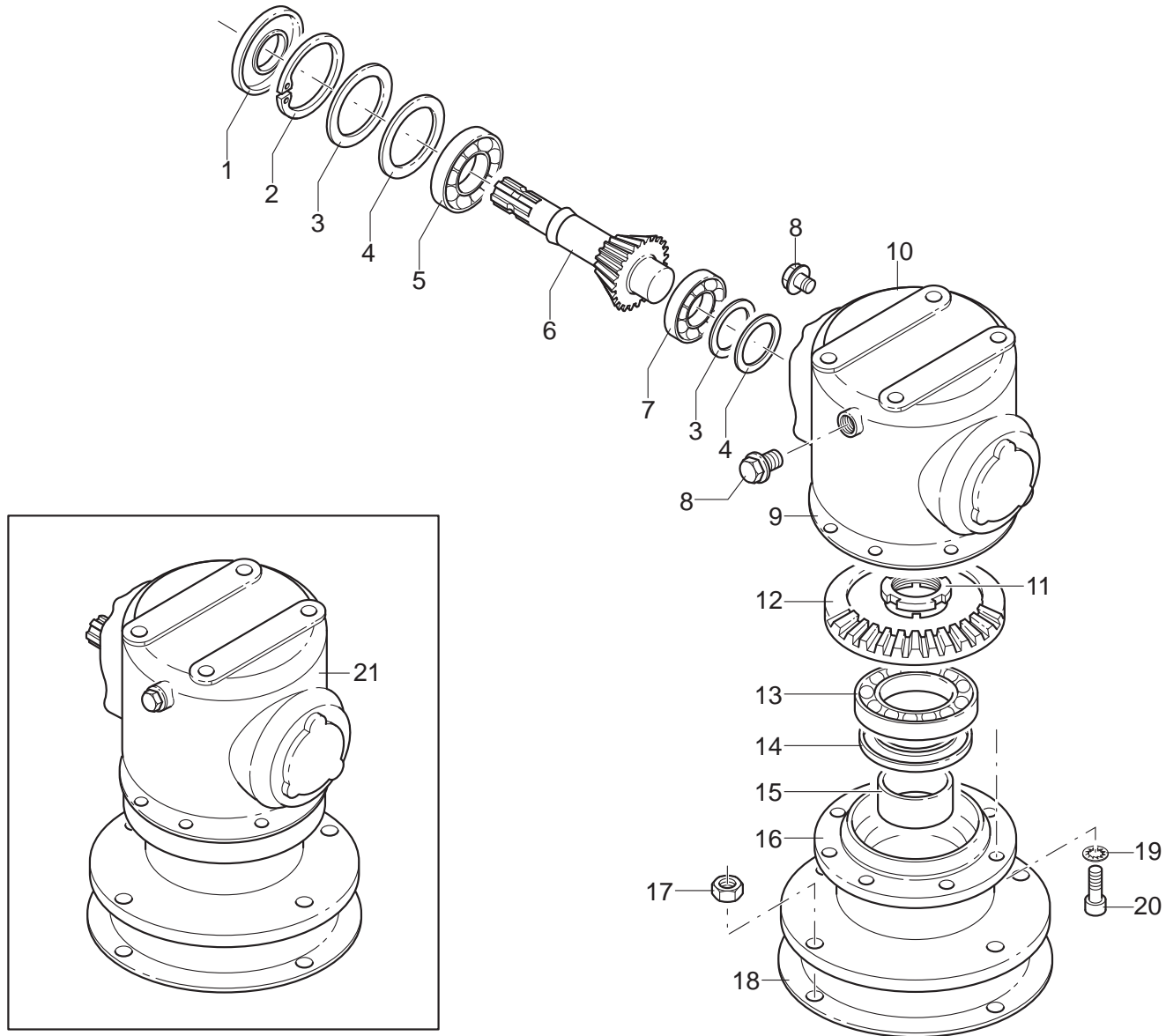

MURATORI ME1

TAV. 4.0

POS.	N°	CODICE Q	DESCRIZIONE	DESIGNATION	BENENNUNG	DESCRIPTION	DESIGNAZIONE	Da matr.	Fino matr
								De nr. serie Vom Seriennr. From serial nr.	Jusqu'au nr. serie Bis Seriennr. Up to serial nr.
1	60023000	2	VITE	VIS	SPINDEL	SCREW	TE M 12x30 UNI 5739 8.8 ZNT		
2	62010600	8	DADO	ECROU	MUTTER	NUT	M 12x1,75 AUTOBLOCC.		
3	64002300	2	INGRASSATORE	GRAISSEUR	SCHMIERNIPPEL	GREASE FITTING	M 6x1		
4	67007900	2	SUPPORTO	SUPPORT	HALTERUNG	SUPPORT	UCFL 205		
5	60021200	4	VITE	VIS	SCHRAUBE	SCREW	TE M 12x35 UNI 5739 8.8 ZNT		
6	42020101	1	RULLO GABBIA	ROULEAU CAGE	STABWALZE	CAGE ROLLER	90		
6	42020201	1	RULLO GABBIA	ROULEAU CAGE	STABWALZE	CAGE ROLLER	110		
6	42020301	1	RULLO GABBIA	ROULEAU CAGE	STABWALZE	CAGE ROLLER	130		
6	42020401	1	RULLO GABBIA	ROULEAU CAGE	STABWALZE	CAGE ROLLER	150		
7	39073802	1	BRACCIO SX	BRAS	ARM	ARM			
8	39073702	1	BRACCIO DX	BRAS	ARM	ARM			
9	40281900	1	BRACCIO SX	BRAS	ARM	ARM	90		
9	40247500	1	BRACCIO SX	BRAS	ARM	ARM	110-130-150		132163
9	40325900	1	BRACCIO SX	BRAS	ARM	ARM		132164	
10	60023500	4	VITE	VIS	SCHRAUBE	SCREW	TE M 10x35 UNI 5739 8.8 ZNT		
11	62000500	4	DADO	ECROU	MUTTER	NUT	M 10x1,5 UNI 5587		
12	42065600	1	RULLO	BILLE	WALZE	DRUM	90		
12	42061500	1	RULLO	BILLE	WALZE	DRUM	110		
12	42061000	1	RULLO	BILLE	WALZE	DRUM	130		
12	42061100	1	RULLO	BILLE	WALZE	DRUM	150		
13	40237200	1	RASCHIARULLO	GRATTOIR	ABSTREIFER	SCRAPER	90		
13	40237300	1	RASCHIARULLO	GRATTOIR	ABSTREIFER	SCRAPER	110		
13	40237400	1	RASCHIARULLO	GRATTOIR	ABSTREIFER	SCRAPER	130		
13	40237500	1	RASCHIARULLO	GRATTOIR	ABSTREIFER	SCRAPER	150		
14	40282000	1	BRACCIO DX	BRAS	ARM	ARM	90		
14	40247600	1	BRACCIO DX	BRAS	ARM	ARM	110-130-150		132163

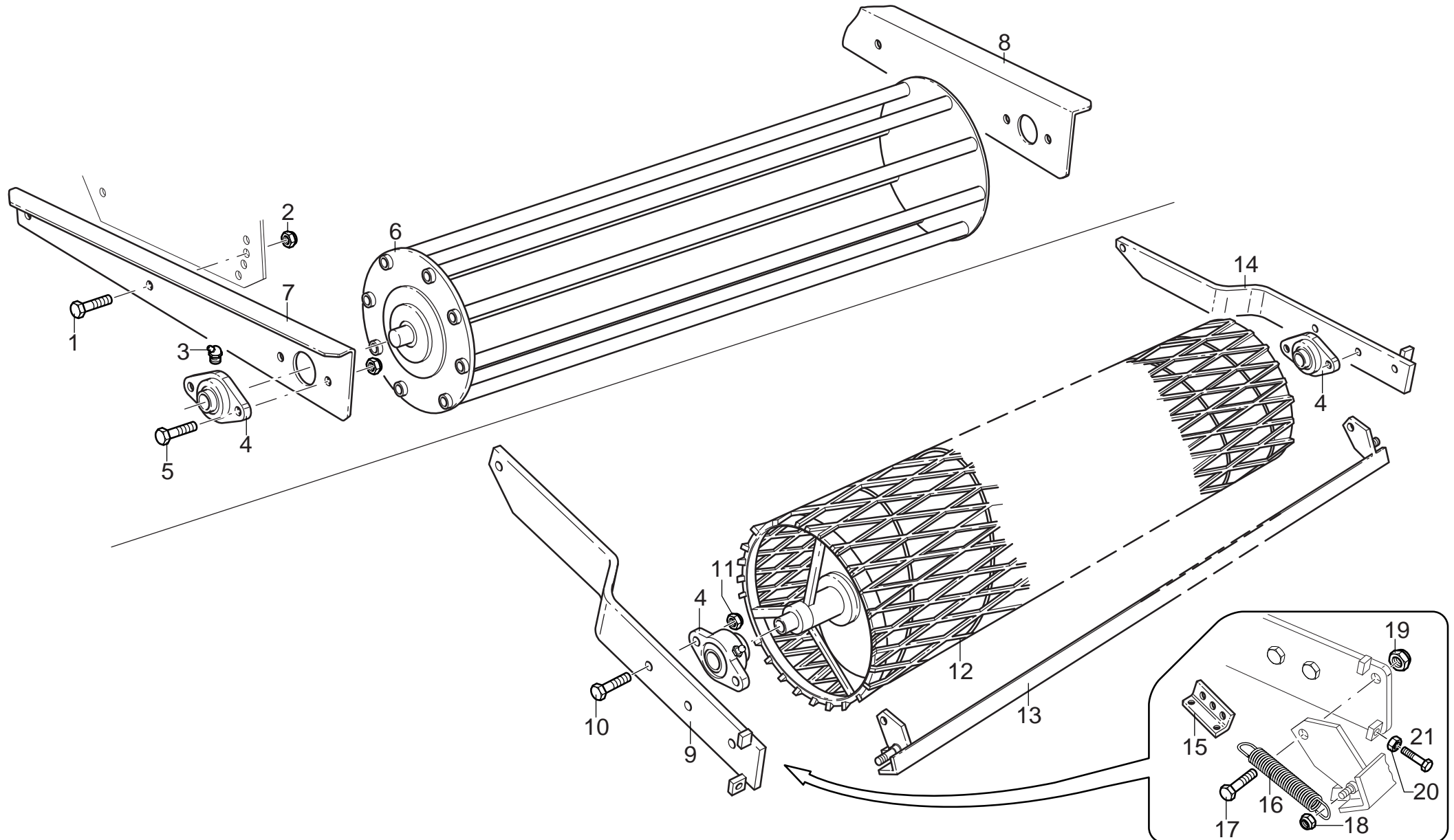

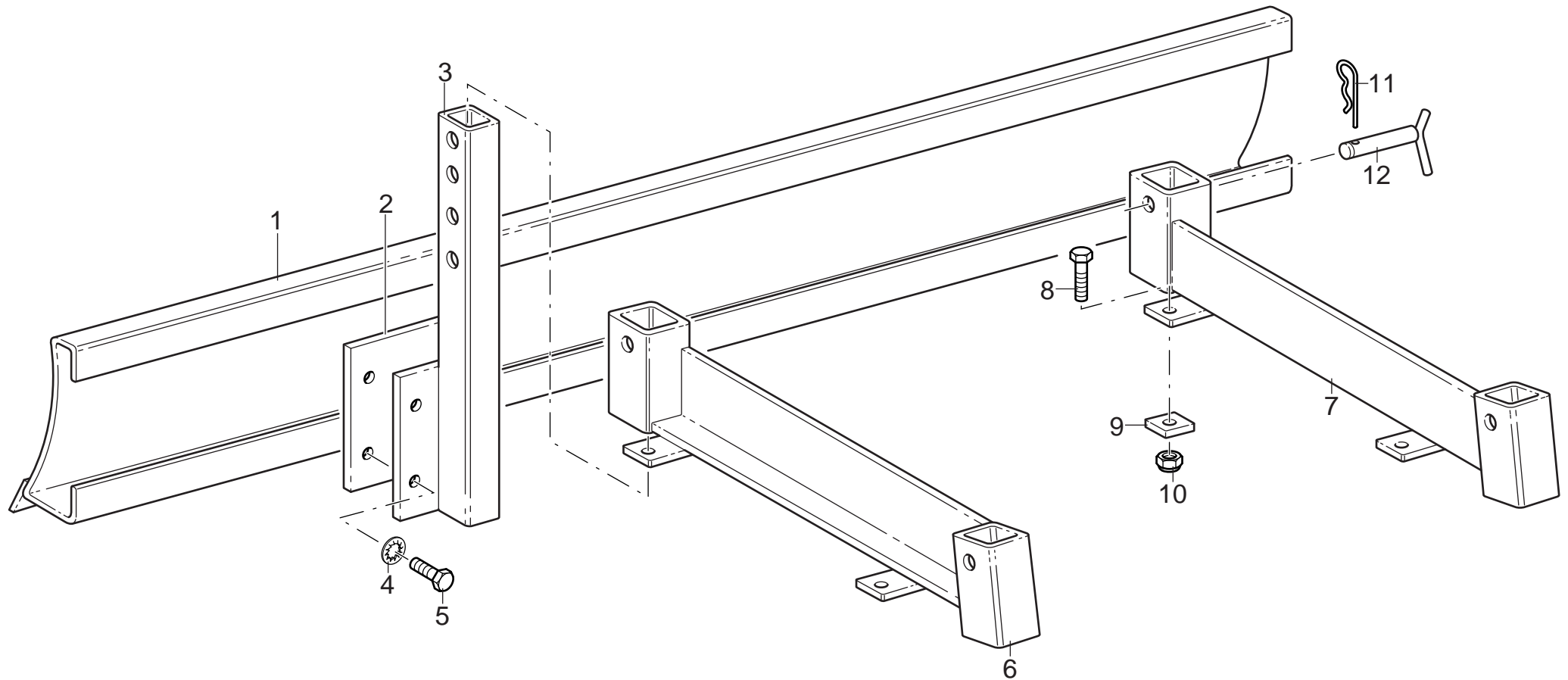

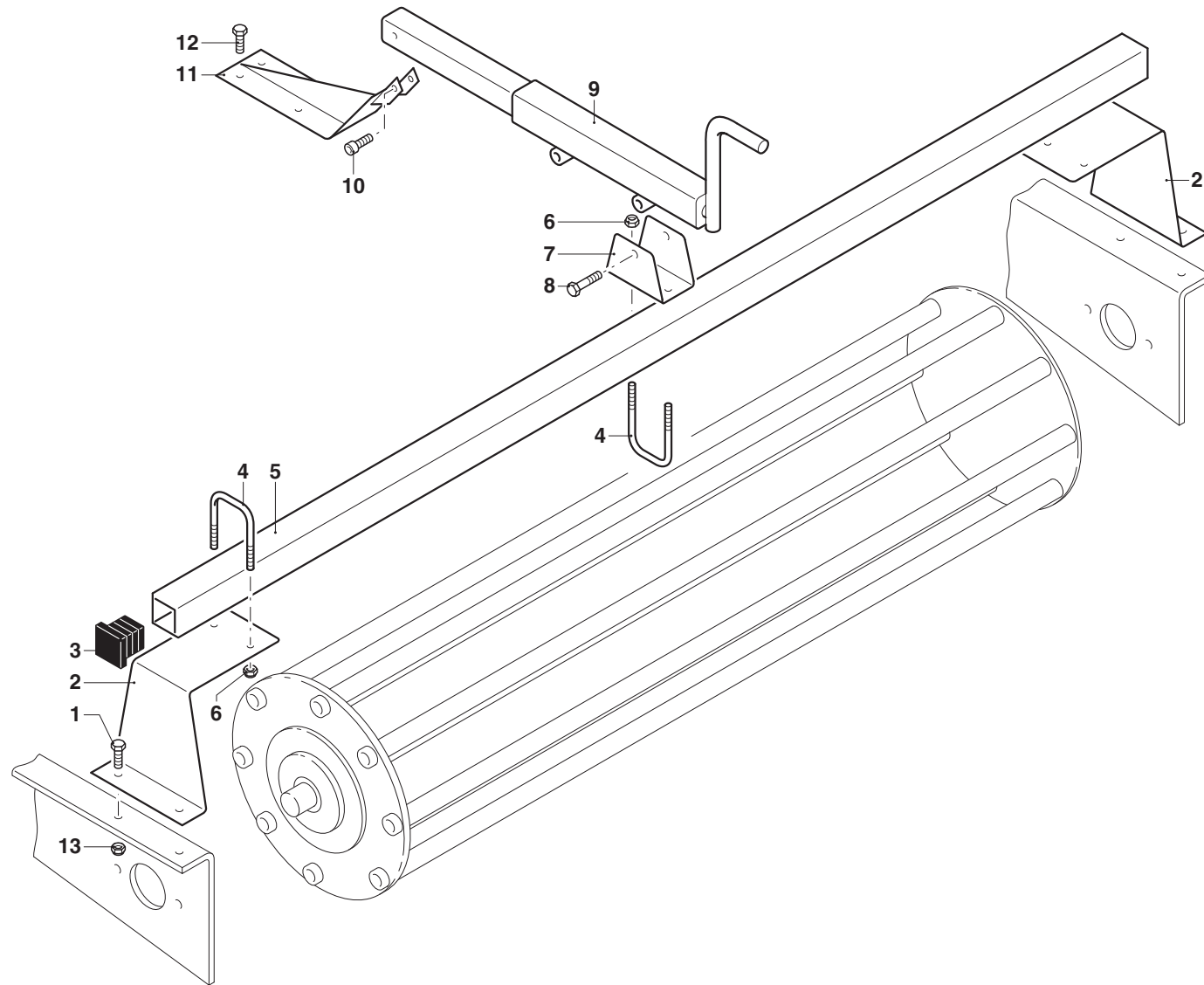

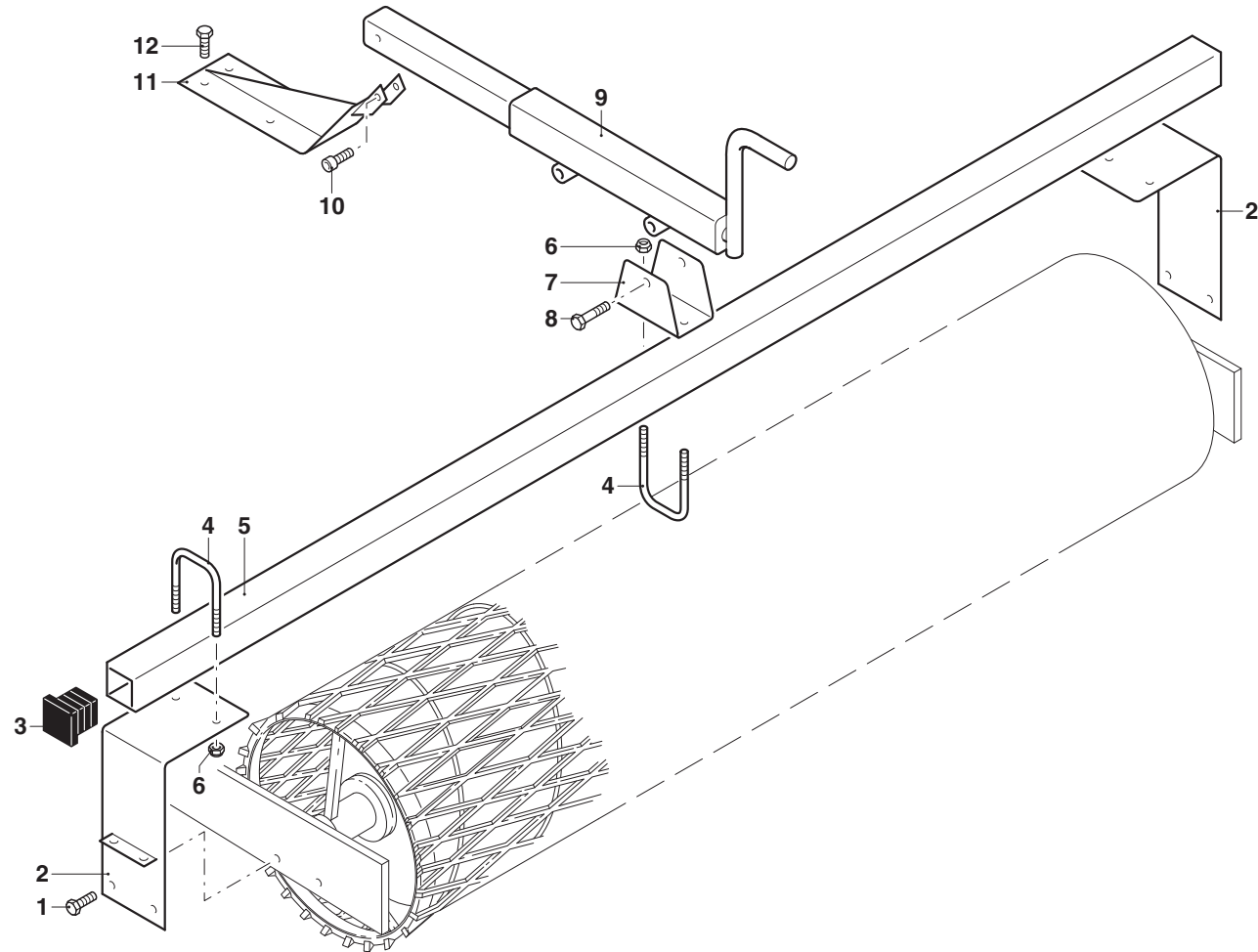

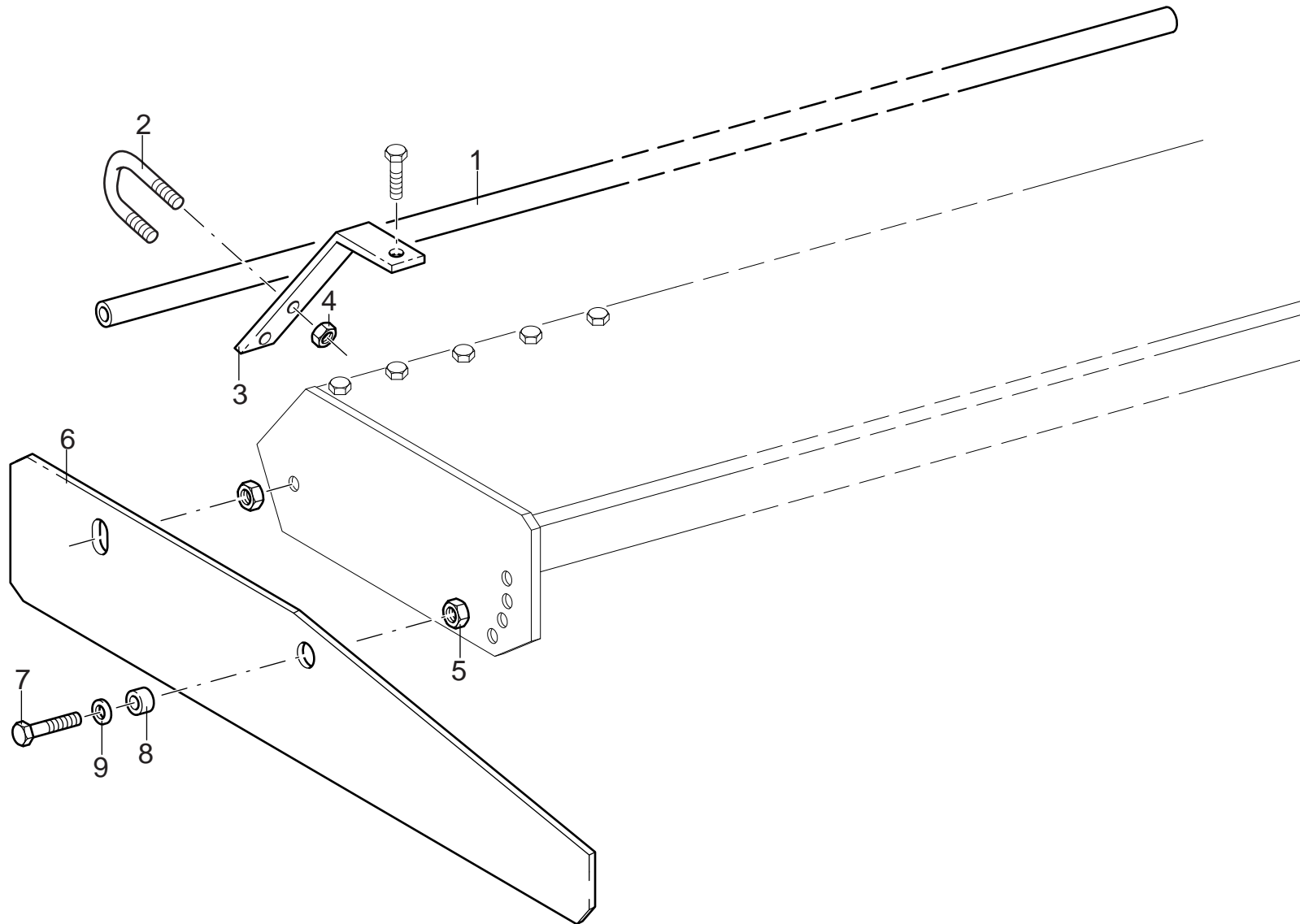

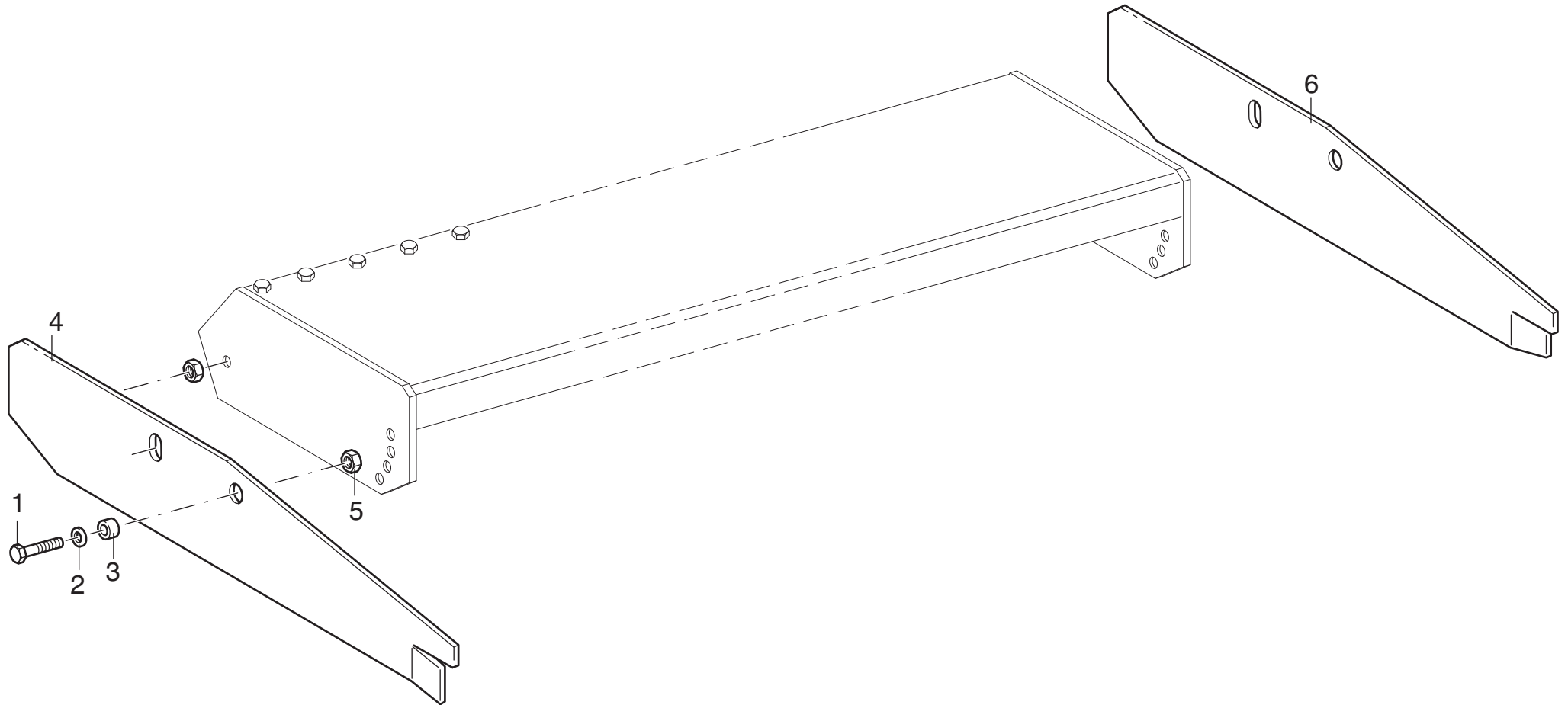

fino a matricola - jusqu'au nr. serie - bis Seriennr. - up to serial 131569

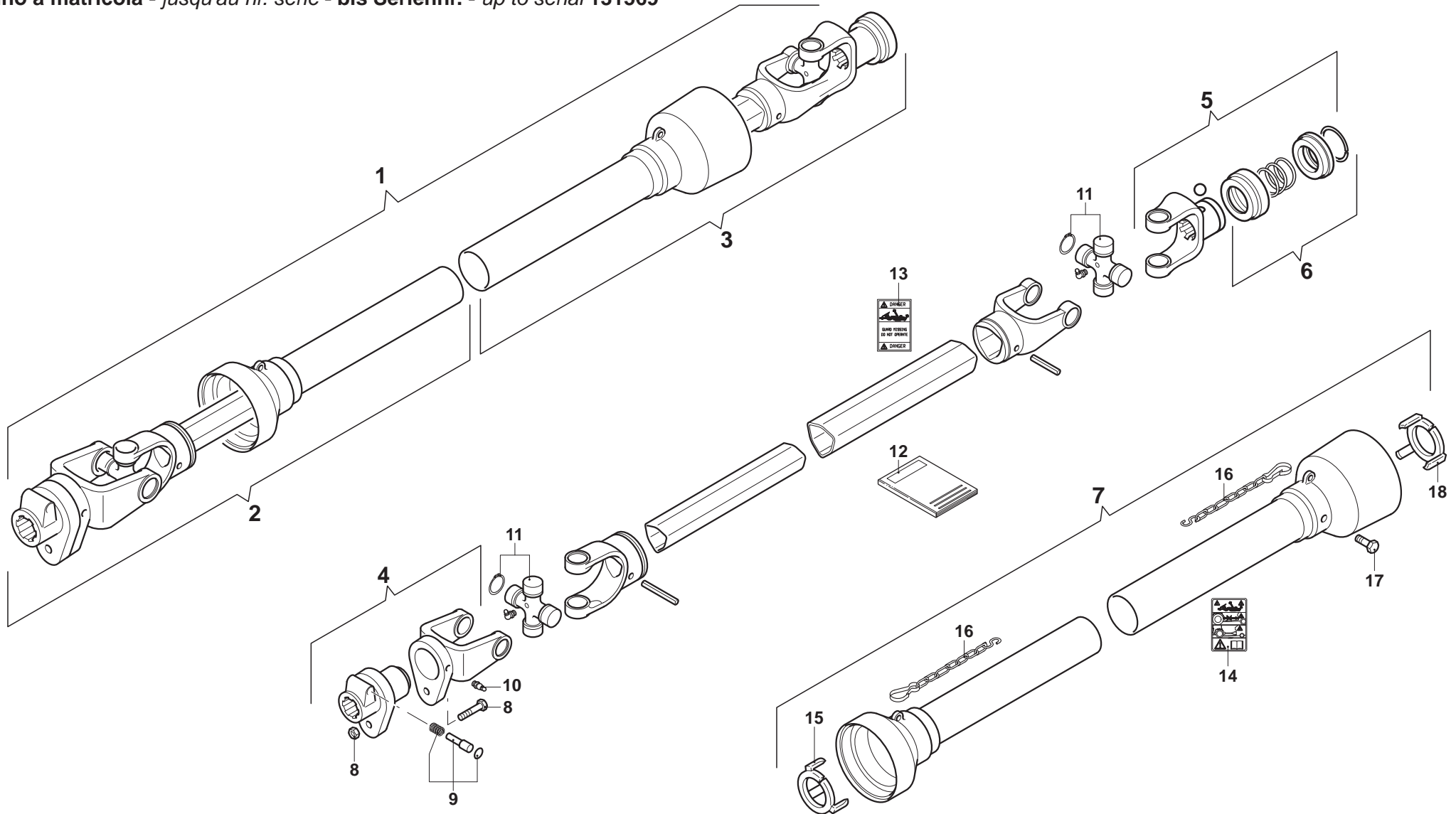

da matricola - de nr. serie - vom Seriennr. - from serial 131570

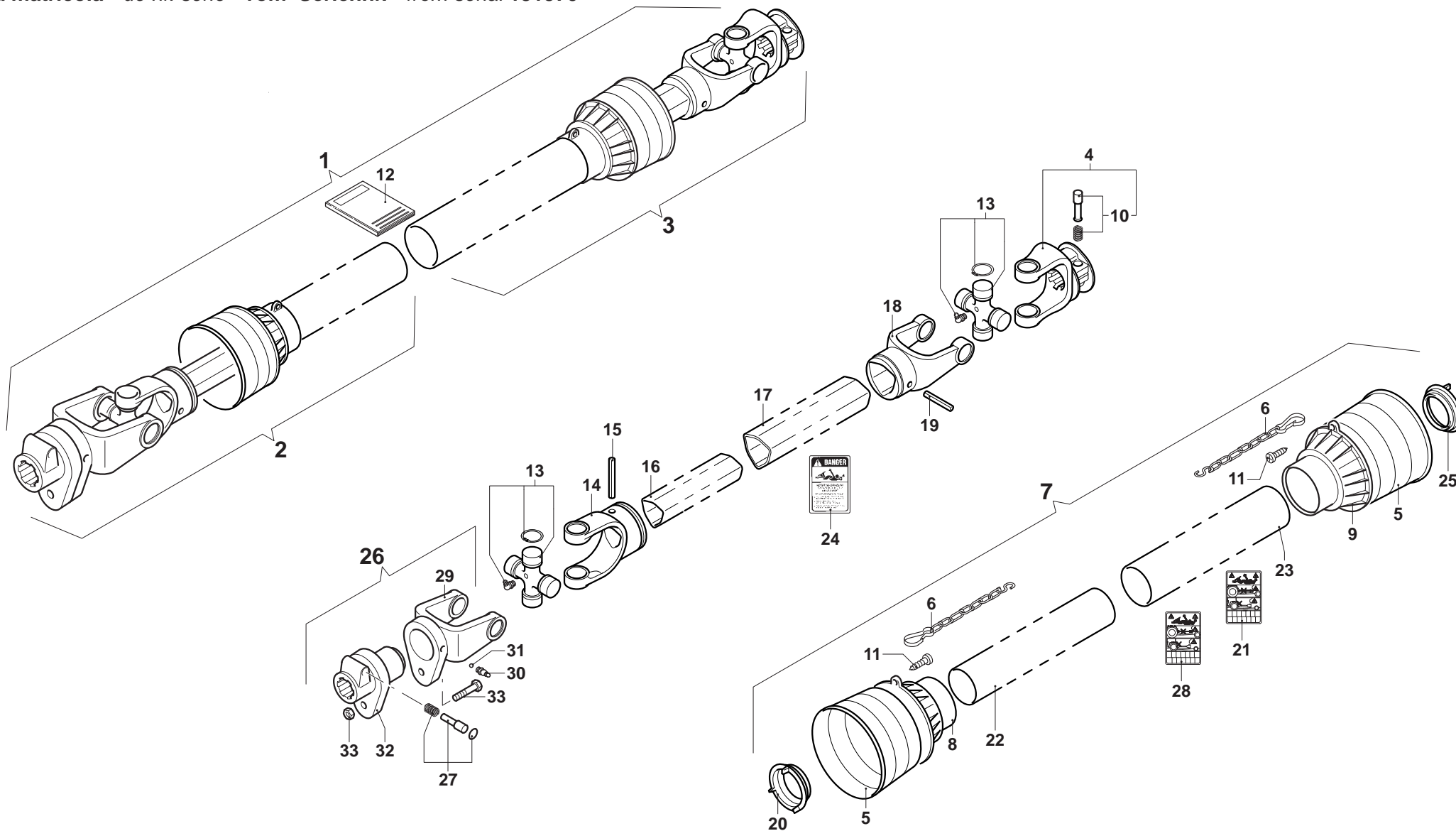

MURATORI ME1

TAV. 8.1

POS.	N°	CODICE Q	DESCRIZIONE	DESIGNATION	BENENNUNG	DESCRIPTION	DESIGNAZIONE	Da matr.	Fino matr.
								De nr. serie Vom Seriennr. From serial nr.	Jusqu'au nr. serie Bis Seriennr. Up to serial nr.
1		AB207FSBDO 1	ALBERO CARDANICO COMPLETO	ARBRE A JOINTS DE CARDAN	KARDANWELLE	PTO SHAFT		131570	
2		B2N051CE10981	SEMIALBERO INTERNO	DEMI-ARBRE INTERIEUR	INNENHALBWELLE	INTERNAL HALF SHAFT		131570	
3		B2N051CE20011	SEMIALBERO ESTERNO	DEMI-ARBRE EXTERIEUR	AUSSENHALBWELLE	EXTERNAL HALF SHAFT		131570	
4		0800203 1	FORCELLA	FOURCHE	GABEL	YOKE		131570	
5		021902C001 2	CUFFIA	CAPOUCHON	HAUBE	GUARD		131570	
6		0252000001 2	CATENA	CHAINE	KETTE	CHAIN		131570	
7		083CE02051 1	PROTEZIONE	PROTECTION	SCHUTZ	GUARD		131570	
8		025402C002 1	PROTEZIONE INTERNA	PROTECTION INTERIEURE	INNENSCHUTZ	INTERNAL GUARD		131570	
9		025402C001 1	PROTEZIONE ESTERNA	PROTECTION EXTERIEURE	AUSSENSCHUTZ	EXTERNAL GUARD		131570	
10		0986014042 1	PULSANTE	BOUTON	DRUCKKNOPF	PUSH BOTTON		131570	
11		0998052242 6	VITE	VIS	SCHRAUBE	SCREW		131570	
12		09872101 1	MANUALE ISTRUZIONI	MANUEL D'UTILISATION ET D'ENTRETIEN	BETRIEBS- UND WARTUNGSANLEITUNG	USE AND MAINTENANCE MANUAL		131570	
13		08202 2	CROCIERA	CROISILLON	KREUZSTÜCK	SPIDER		131570	
14		08002011 1	FORCELLA	FOURCHE	GABEL	YOKE		131570	
15		098700850 1	SPINA ELASTICA	GOUPILLE ELASTIQUE	SPANNSTIFT	ELASTIC PIN		131570	
16		09881294100 1	TUBO INTERNO	TUBE INTERIEUR	INNENROHR	INTERNAL TUBE		131570	
17		09881363100 1	TUBO ESTERNO	TUBE EXTERIEUR	AUSSENROHR	EXTERNAL TUBE		131570	
18		08002021 1	FORCELLA	FOURCHE	GABEL	YOKE		131570	
19		098700855 1	SPINA ELASTICA	GOUPILLE ELASTIQUE	SPANNSTIFT	ELASTIC PIN		131570	
20		025502C002 1	GHIERA	FRETTE	NUTMUTTER	RING NUT		131570	
21		09872010 1	ETICHETTA	ETIQUETE	ETIKETT	LABEL		131570	
22		0988955NB051 1	TUBO INTERNO	TUBE INTERIEUR	INNENROHR	INTERNAL TUBE		131570	
23		0988961NB051 1	TUBO ESTERNO	TUBE EXTERIEUR	AUSSENROHR	EXTERNAL TUBE		131570	
24		09872006 1	ETICHETTA	ETIQUETE	ETIKETT	LABEL		131570	
25		025502C001 1	GHIERA	FRETTE	NUTMUTTER	RING NUT		131570	
26		08002 1	FORCELLA	FOURCHE	GABEL	YOKE		131570	

da matricola - de nr. serie - vom Seriennr. - from serial 131570

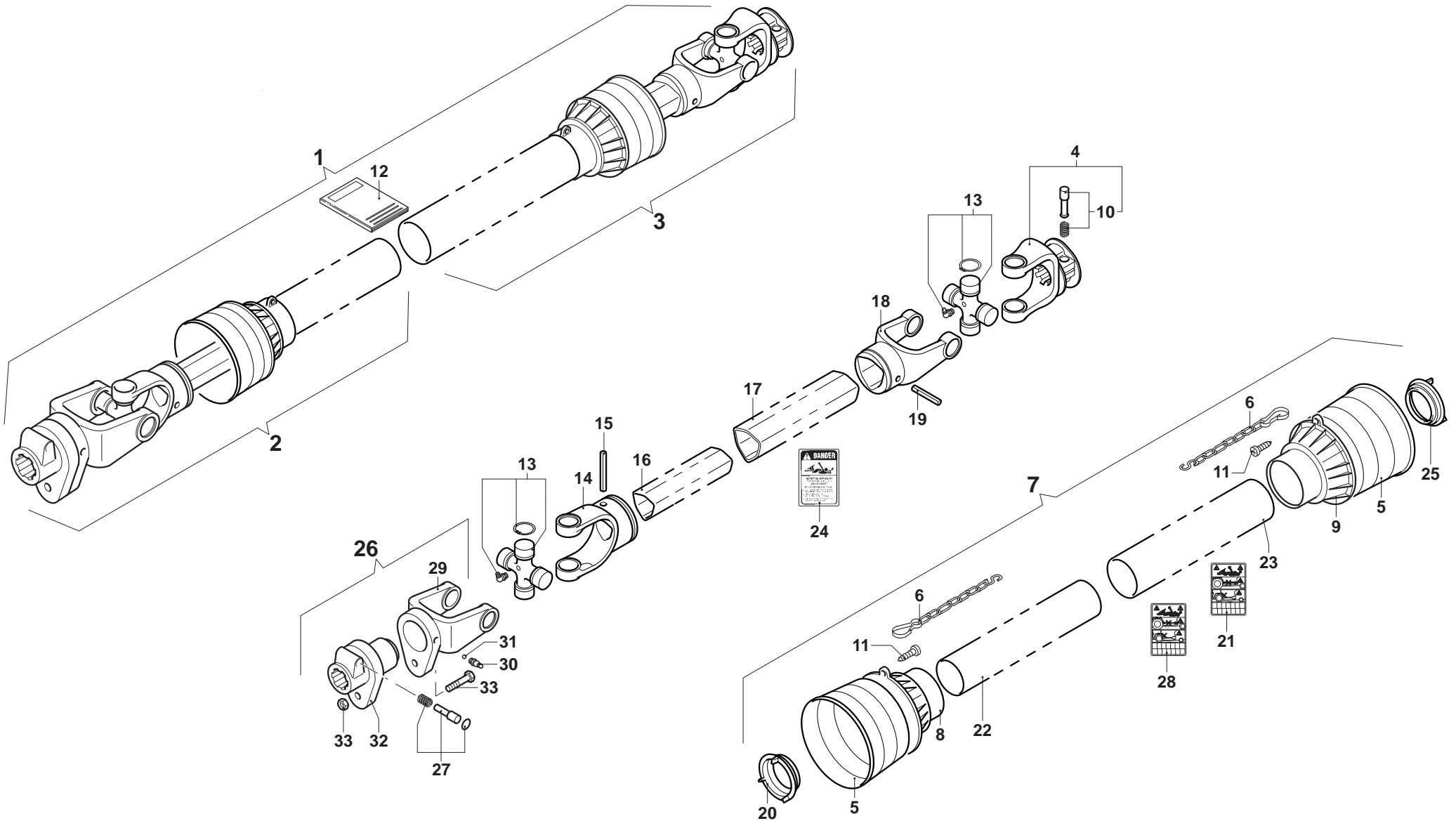

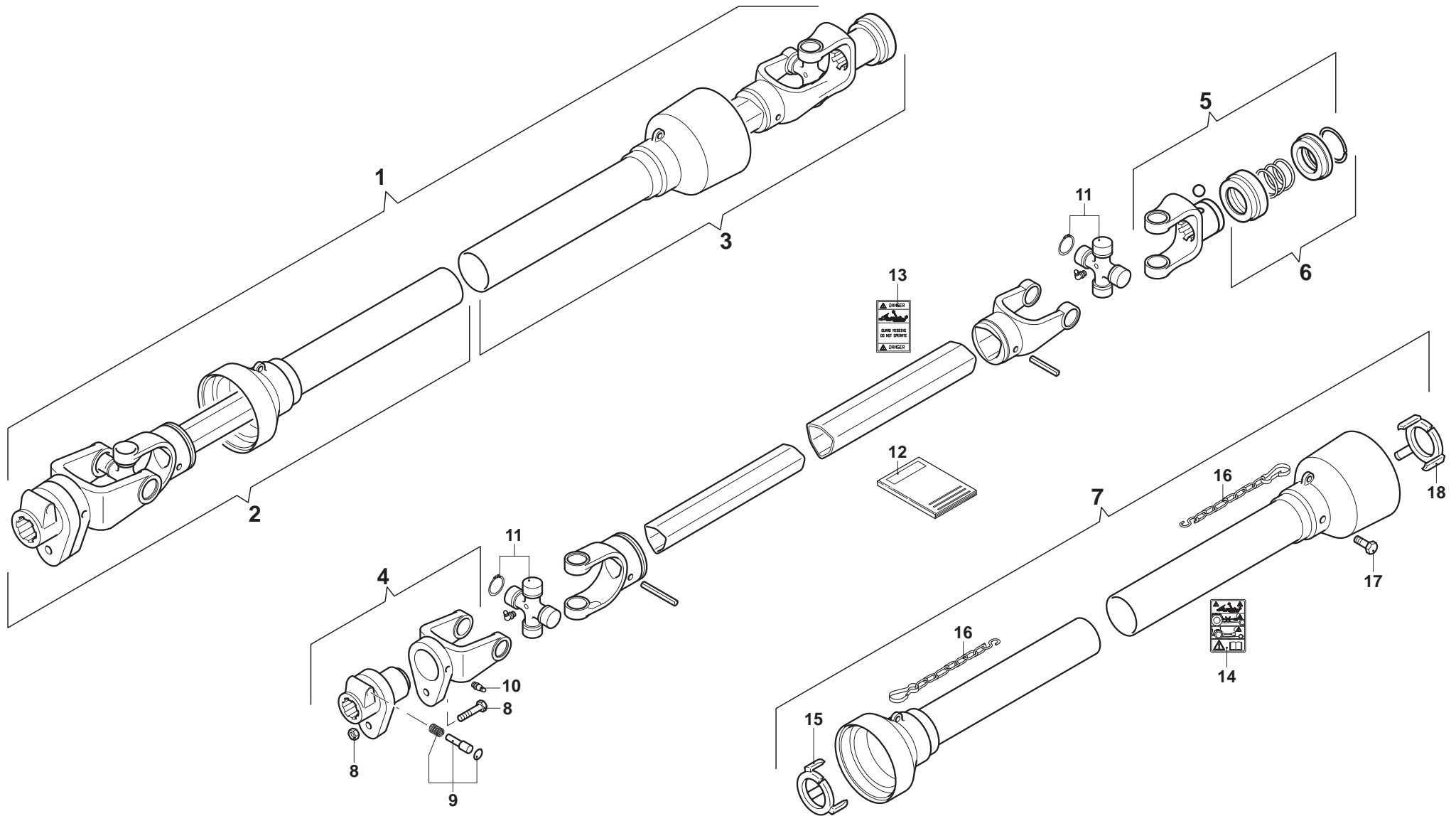



MURATORI S.p.A.

Via Pavarello, 21 - 41051 Castelnuovo Rangone (MO) Italy - Tel. 059.5330611 Fax 059.537259

www.muratoriequip.it *info@muratoriequip.it*

Capitale sociale Euro 480.000 interamente versato

Registro Imprese di Modena

Codice fiscale e numero d'iscrizione: 00708860366