



MURATORI

TIPO-TYPE-TYP
ME 22
ME 22 C

CATALOGO RICAMBI
Catalogue Pièces Detachées
Ersatzteilkatalog
Spare Parts Catalogue
Catálogo Recambios

EDIZIONE 09/2019

Per ordinare parti di ricambio specificare:

- tipo e matricola della macchina (apposti sulla macchina o sui documenti di acquisto);
- numero del riferimento del pezzo nel disegno (Pos.), numero della tavola (Tav.) e numero di codice

N.B.: le indicazioni destro o sinistro vengono date guardando la macchina da dietro.

Pour les commandes de pièces de rechange veuillez spécifier:

- *type et numéro de série de la machine (indiqués sur la machine et sur le bon d'achat);*
- *numéro de référence du pièce sur le plan (Pos.), numéro du plan (Tav.) et numéro de code (codice)*

N.B.: *les indications droite ou gauche sont données en regardant la machine par derrière.*

Zum Bestellen von Ersatzteilen folgendes angeben:

- *Typ und Serien-Nr. der Maschine (zu finden auf der Maschine oder der Einkaufspapieren);*
- *Bezug-Nr. des Ersatzteils auf der Zeichnung (Pos.), Zeichnungsnummer (Tav.) und Kodenummer (codice)*

N.B.: *Die Angaben rechts und links verstehen sich so, dass man hinter der Maschine steht.*

When ordering spare parts specify:

- machine type and serial number (found on the machine or on the purchasing documents);
- reference number of the part on the relative drawing (Pos.) number of the drawing (Tav.) and part number (codice)

N.B.: right-hand or left-hand indications are made by viewing the machine from the rear.

TAV. 1.0

GRUPPO TELAIO
ENSEMBLE CHASSIS
SATZ FÜR RAHMEN
KIT FOR FRAME

TAV. 1.1 (130-150-170)

ATTACCO 3 PUNTI
ATTELAGE 3 POINTS
3 PUNKT-ANSCHLUSS
THREE-POINT LINKAGE

TAV. 1.2 (200-250)

ATTACCO 3 PUNTI
ATTELAGE 3 POINTS
3 PUNKT-ANSCHLUSS
THREE-POINT LINKAGE

TAV. 2.0

GRUPPO FIANCHI SUPPLEMENTARI
ENSEMBLE FLANCS SUPPLEMENTAIRES
SATZ ZUSÄTZLICHE SEITENWÄNDE
KIT OF ADDITIONAL SIDE SHIELDS

TAV. 3.0

GRUPPO ROTORI
ENSEMBLE ROTORS
SATZ FÜR ROTOREN
KIT FOR ROTORS

TAV. 4.0

GRUPPO RIDUTTORE A 1 VELOCITA'
ENSEMBLE BOITIER 1 VITESSE
SATZ FÜR 1-GANGGETRIEBE
KIT FOR 1 -SPEED GEAR BOX

TAV. 4.1

GRUPPO RIDUTTORE A 4 VELOCITA'
ENSEMBLE BOITIER 4 VITESSE
SATZ FÜR 4-GANGGETRIEBE
KIT FOR 4 -SPEED GEAR BOX

TAV. 5.0

GRUPPO RULLO POSTERIORE
ENSEMBLE ROULEAU ARRIERE
SATZ HINTERE WALZE
KIT REAR ROLLER

TAV. 5.1

GRUPPO RULLO POSTERIORE
ENSEMBLE ROULEAU ARRIERE
SATZ HINTERE WALZE
KIT REAR ROLLER

TAV. 5.2

GRUPPO RULLO POSTERIORE
ENSEMBLE ROULEAU ARRIERE
SATZ HINTERE WALZE
KIT REAR ROLLER

TAV. 5.3

GRUPPO RULLO POSTERIORE
ENSEMBLE ROULEAU ARRIERE
SATZ HINTERE WALZE
KIT REAR ROLLER

TAV. 6.0

BARRA LIVELLATRICE POSTERIORE
BARRE NIVELLEUSE ARRIERE
HINTERE PLANIERSCHIENE
REAR LEVELLING BAR

TAV. 7.0 (250)

ATTACCO POSTERIORE MECCANICO
ATTELAGE ARR. MECANIQUE
HINT. MECHANISCHES HITCH
REAR MECHANICAL HITCH

TAV. 8.0 (250)

ATTACCO POSTERIORE IDRAULICO
ATTELAGE ARR. HYDRAULIQUE
HINT. HYDRAULISCHES HITCH
REAR HYDRAULIC HITCH

TAV. 9.0

PROTEZIONI ANTINFORTUNISTICHE "CE"
PROTECTIONS "CE"
"CE" UNFALLSCHUTZVORRICHTUNGEN
"CE" SAFETY GUARDS

TAV. 10.0 (130-250)

ALBERO CARDANICO COMPLETO - A6085FLR
ARBRE A JOINTS DE CARDAN - A6085FLR
KARDANWELLE - A6085FLR
PTO SHAFT - A6085FLR

TAV. 11.0 (130-250)

ALBERO CARDANICO COMPLETO - AB6085FSB
ARBRE A JOINTS DE CARDAN - AB6085FSB
KARDANWELLE - AB6085FSB
PTO SHAFT - AB6085FSB

TAV. 12.0 (200)

ALBERO CARDANICO COMPLETO - A6085FLR
ARBRE A JOINTS DE CARDAN - A6085FLR
KARDANWELLE - A6085FLR
PTO SHAFT - A6085FLR

TAV. 13.0 (200)

ALBERO CARDANICO COMPLETO - AB6085FSB
ARBRE A JOINTS DE CARDAN - AB6085FSB
KARDANWELLE - AB6085FSB
PTO SHAFT - AB6085FSB

TAV. 14.0 (250)

ALBERO CARDANICO COMPLETO - A809FSBG
ARBRE A JOINTS DE CARDAN - A809FSBG
KARDANWELLE - A809FSBG
PTO SHAFT - A809FSBG

TAV. 15.0 (250)

ALBERO CARDANICO COMPLETO - A809FLRG
ARBRE A JOINTS DE CARDAN - A809FLRG
KARDANWELLE - A809FLRG
PTO SHAFT - A809FLRG

TAV. 16.0 (200-250)

ALBERO CARDANICO COMPLETO - A809FSBG
ARBRE A JOINTS DE CARDAN - A809FSBG
KARDANWELLE - A809FSBG
PTO SHAFT - A809FSBG

TAV. 16.1

ALBERO CARDANICO COMPLETO - AB809FSBG
ARBRE A JOINTS DE CARDAN - AB809FSBG
KARDANWELLE - AB809FSBG
PTO SHAFT - AB809FSBG

TAV. 17.0 (200-250)

ALBERO CARDANICO COMPLETO - A809FLRG
ARBRE A JOINTS DE CARDAN - A809FLRG
KARDANWELLE - A809FLRG
PTO SHAFT - A809FLRG

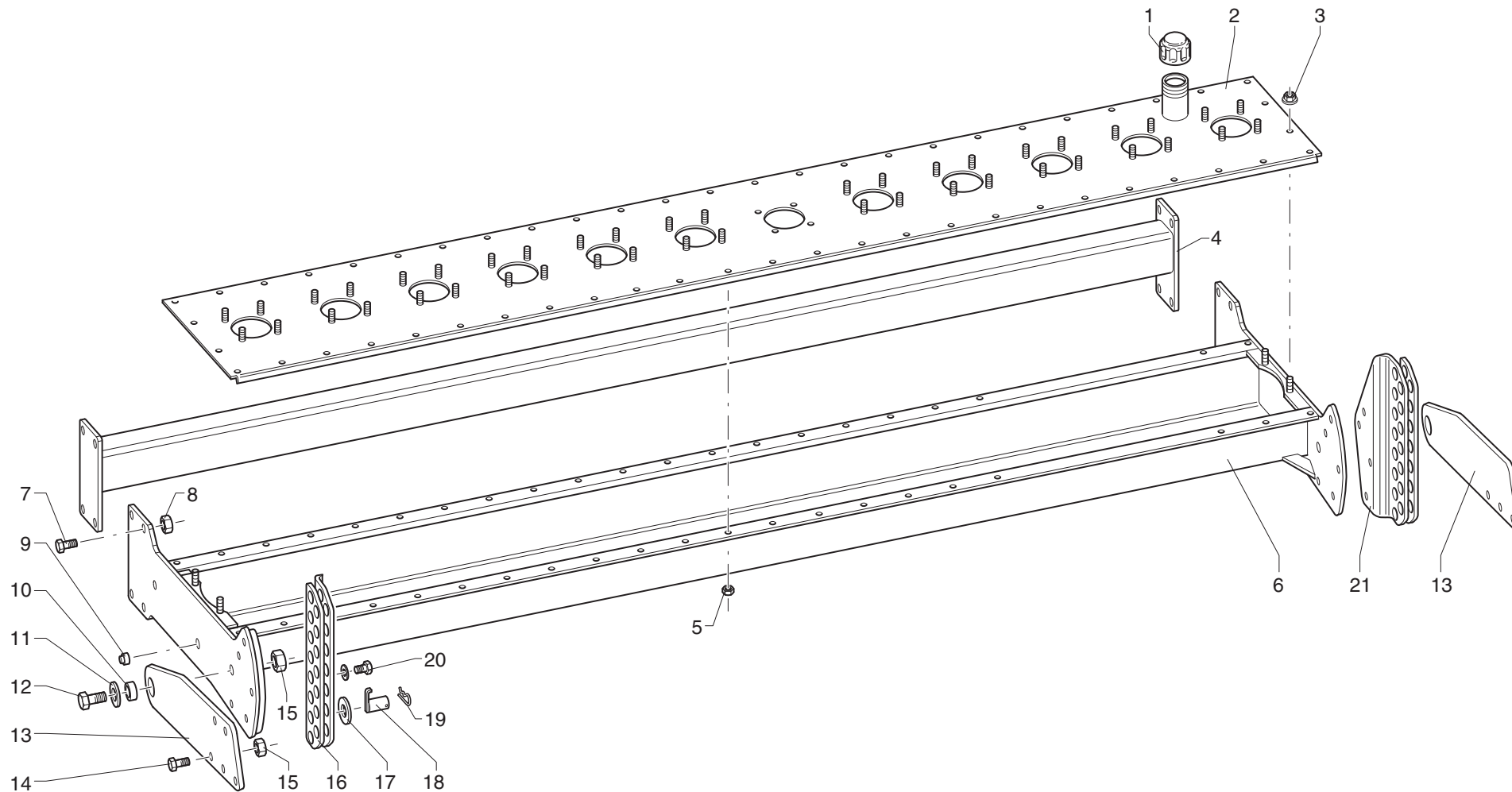

MURATORI ME 22 - ME 22 C

TAV. 1.0

POS.	N° CODICE	Q.	DESCRIZIONE	DESIGNATION	BENENNUNG	DESCRIPTION	DESIGNAZIONE	Da matr. De nr. serie Vom Seriennr. From serial nr.	Fino matr. Jusqu'au nr. serie Bis Seriennr. Up to serial nr.
1	68097000	1	TAPPO	BOUCHON	STOPFEN	PLUG			
2	40274600	1	COPERCHIO	COUVERCLE	DECKEL	COVER	130		
2	40274700	1	COPERCHIO	COUVERCLE	DECKEL	COVER	150		
2	40274800	1	COPERCHIO	COUVERCLE	DECKEL	COVER	170		
2	40274900	1	COPERCHIO	COUVERCLE	DECKEL	COVER	200		
2	40275000	1	COPERCHIO	COUVERCLE	DECKEL	COVER	250		
3	62010500	4	DADO	ECROU	MUTTER	NUT	M 12 x 1,5 AUTOBLOCC.		
4	40275600	1	BARRA	BARRE	STANGE	BAR	130		
4	40275700	1	BARRA	BARRE	STANGE	BAR	150		
4	40275800	1	BARRA	BARRE	STANGE	BAR	170		
4	40275900	1	BARRA	BARRE	STANGE	BAR	200		
4	40276000	1	BARRA	BARRE	STANGE	BAR	250		
5	62010500		DADO	ECROU	MUTTER	NUT	M12 x 1,5 AUTOBLOCC.		
6	40275100	1	CASSA	CAISSE	WANNE	GEARCASE	130		
6	40275200	1	CASSA	CAISSE	WANNE	GEARCASE	150		
6	40275300	1	CASSA	CAISSE	WANNE	GEARCASE	170		
6	40275400	1	CASSA	CAISSE	WANNE	GEARCASE	200		
6	40275500	1	CASSA	CAISSE	WANNE	GEARCASE	250		
7	60019600	8	VITE	VIS	SCHRAUBE	SCREW	TE 14 x 1,5 x 50 UNI 5739		
8	62010700	8	DADO	ECROU	MUTTER	NUT	M14 x 1,5 AUTOBLOCC.		
9	68097400		TAPPO	BOUCHON	STOPFEN	PLUG			
10	32186000	2	DISTANZIALE	ENTRETOISE	DISTANZSTUECCK	SPACER			
11	61004600	2	RONDELLA	RONDELLE	SCHEIBE	WASHER	PIANA ϕ 14 ϕ e 46 sp. 4		
12	60033800	2	VITE	VIS	SCHRAUBE	SCREW	TE 14 x 1,5 x 45		
13	39288100	2	BRACCIO	BRAS	ARM	ARM			
14	60022700	8	VITE	VIS	SCHRAUBE	SCREW	TE 14 x 1,5 x 40		

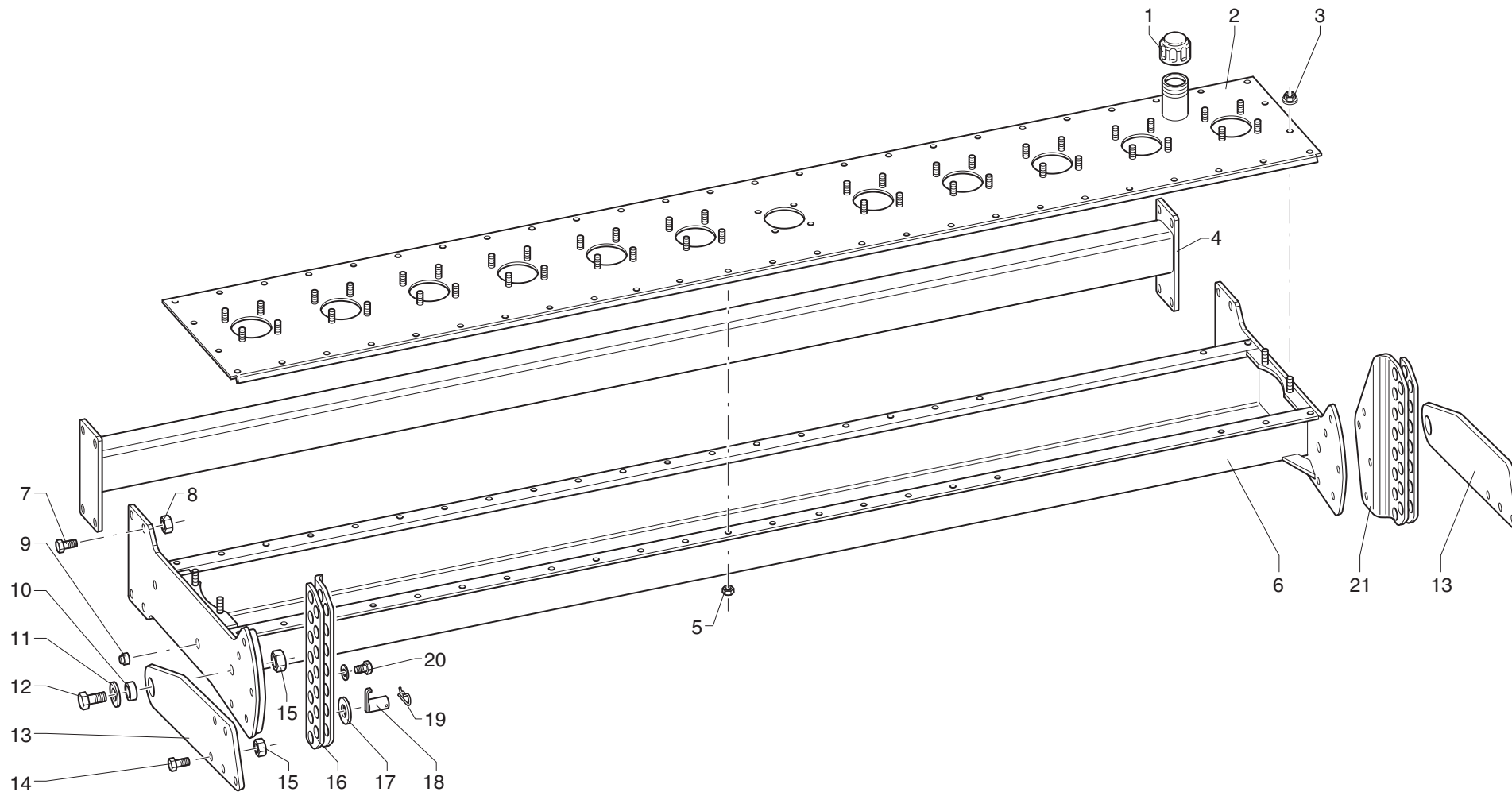

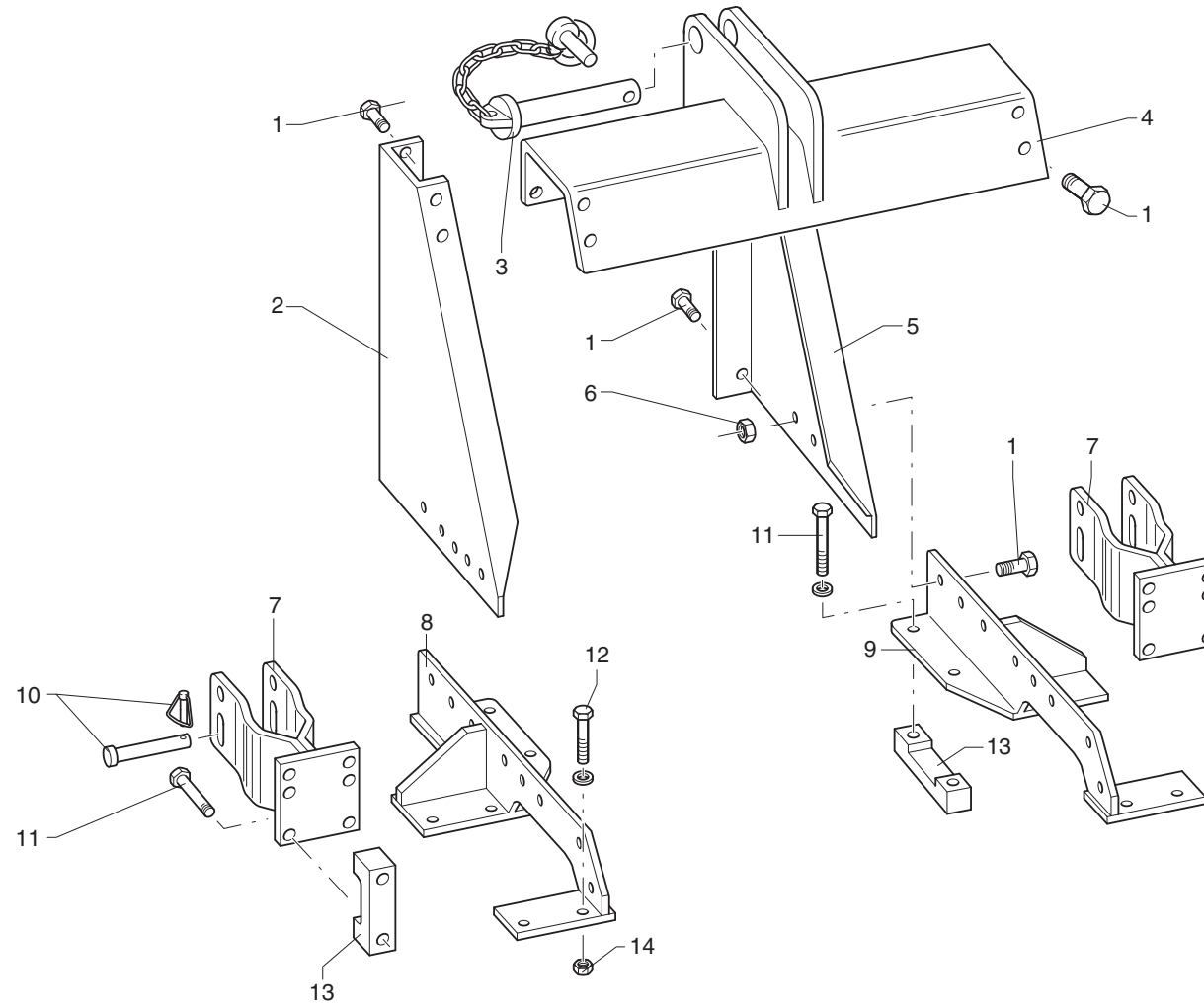

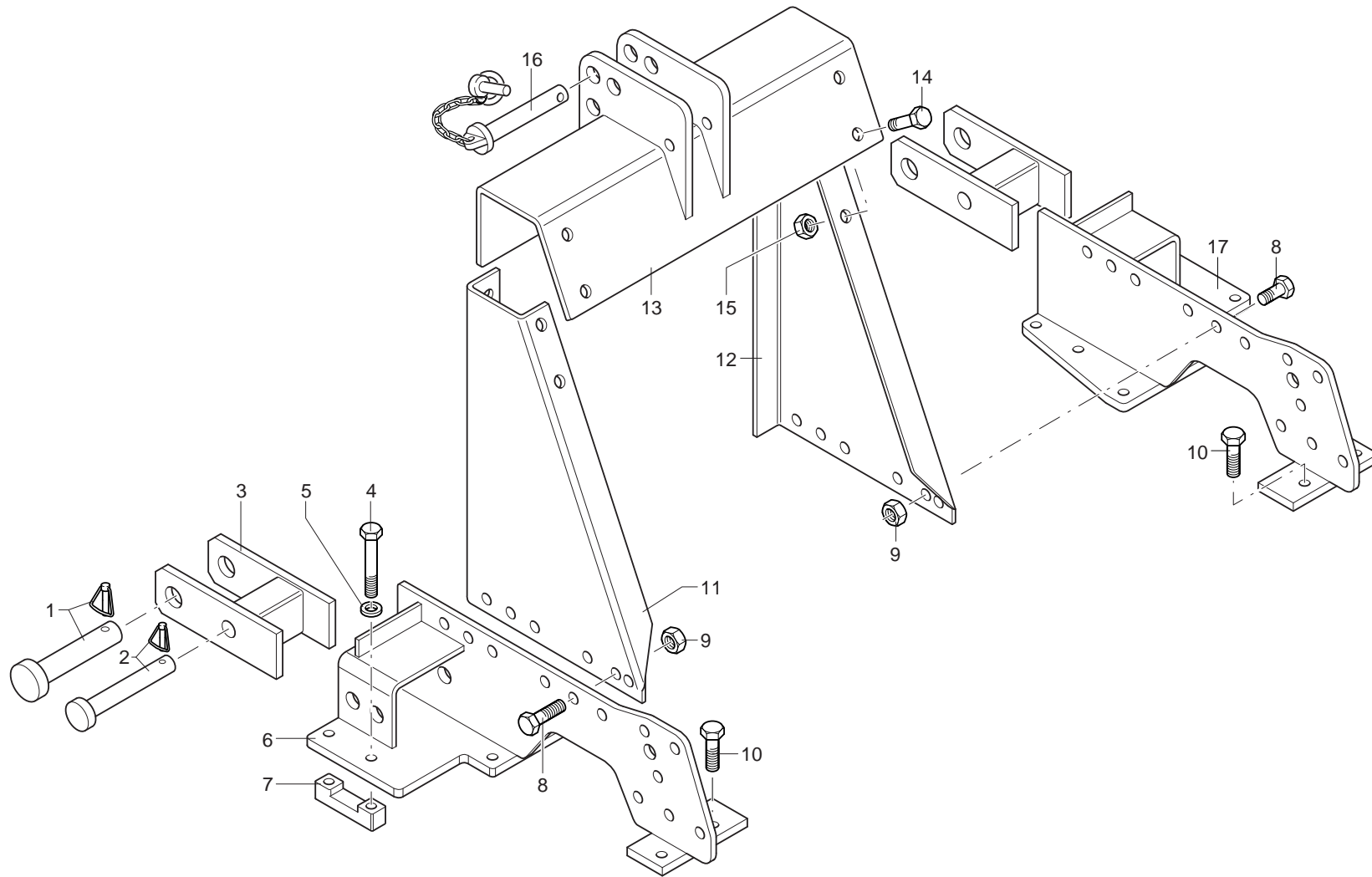

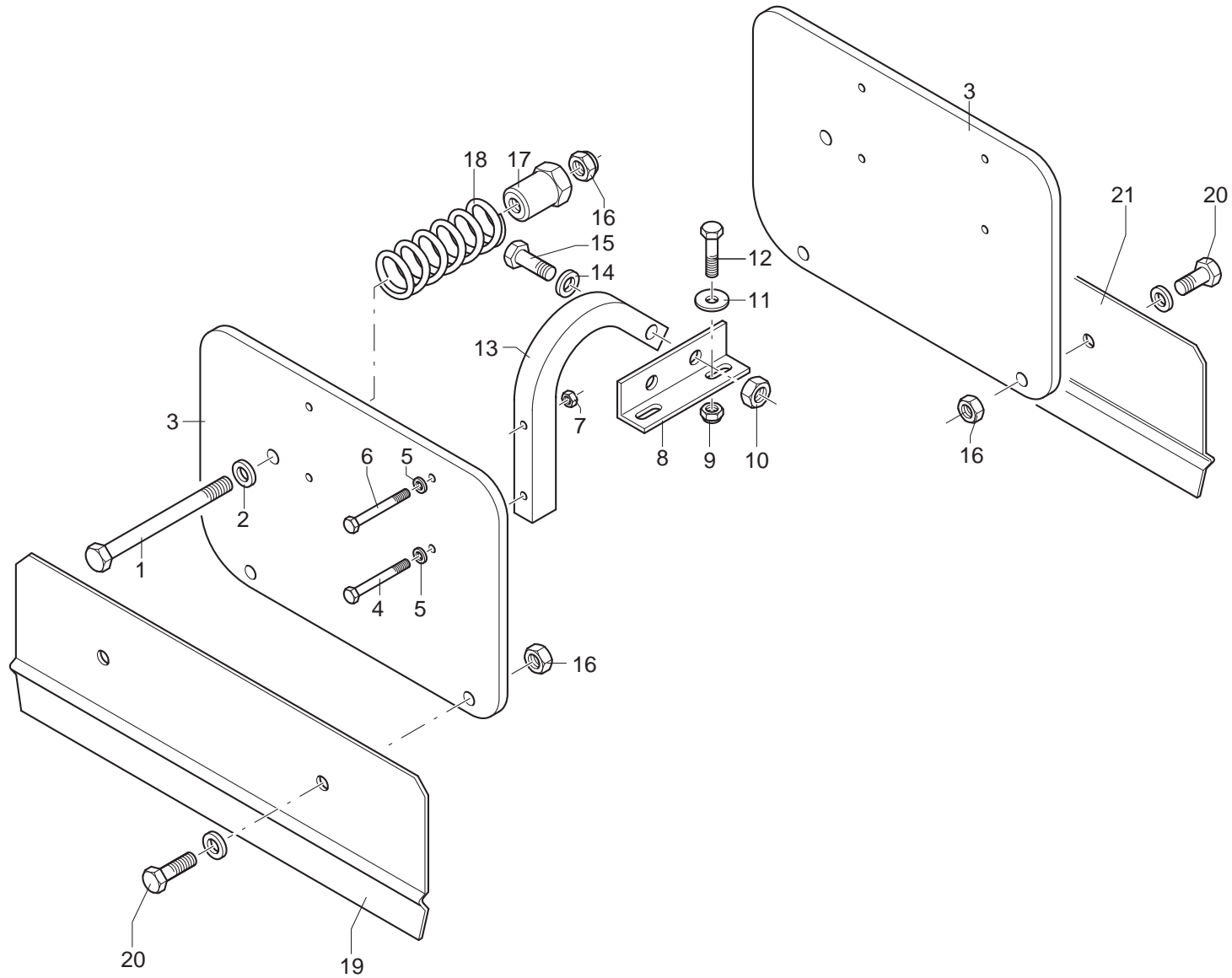

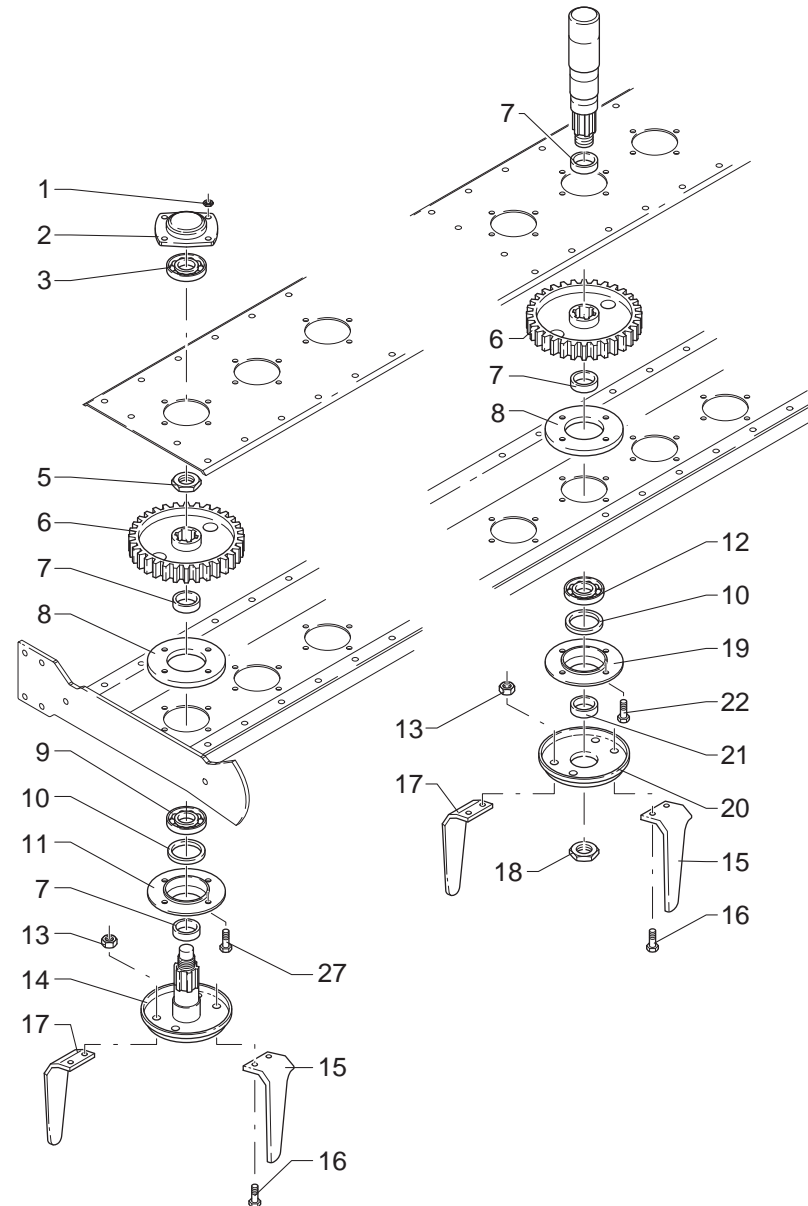

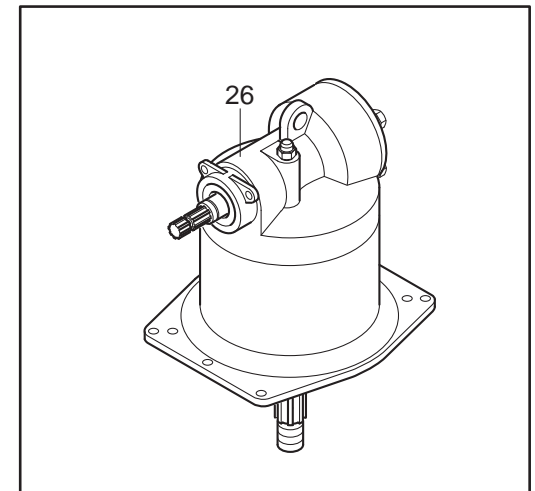
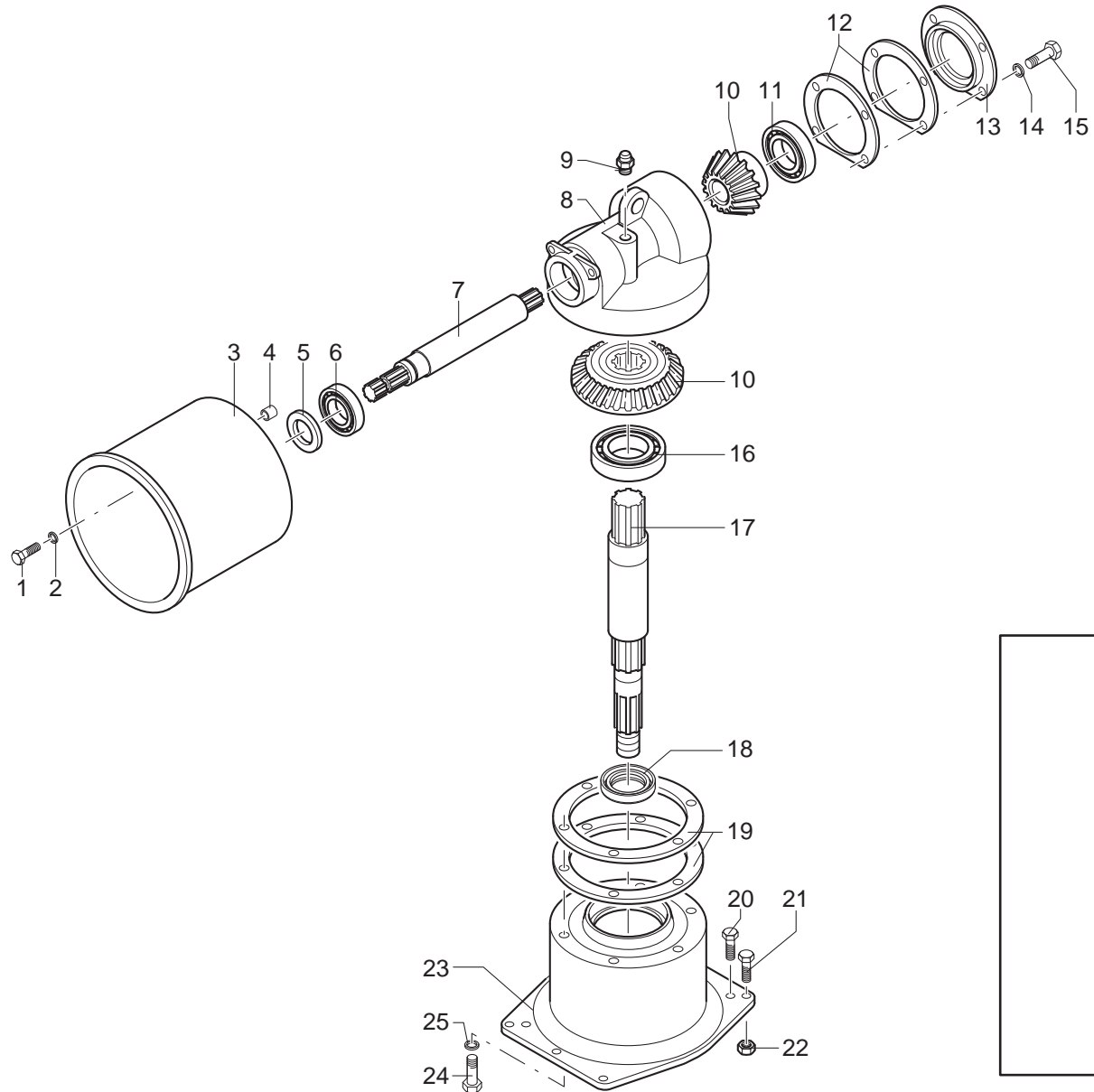

MURATORI ME 22

TAV. 4.0

POS.	N° CODICE	Q.	DESCRIZIONE	DESIGNATION	BENENNUNG	DESCRIPTION	DESIGNAZIONE	Da matr. De nr. serie Vom Seriennr. From serial nr.	Fino matr. Jusqu'au nr. serie Bis Seriennr. Up to serial nr.
1	60021300	2	VITE	VIS	SCHRAUBE	SCREW	TE 10 x 30		
2	61003500	4	RONDELLA	RONDELLE	SCHEIBE	WASHER	PIANA øi 11 øe 30		
3	68077000	1	PROTEZIONE	PROTECTION	SCHUTZ	GUARD			
4	31079300	2	BOCCOLA	DOUILLE	BUECHSE	BUSHING			
5	66012200	1	PARAOLIO	JOINT D'ETAU CHEITE	DICHTRING	OIL SEAL	35 x 62 x 10		
6	67000300	1	CUSCINETTO	ROULEMENT	LAGER	BEARING	30207		
7	31090600	1	ALBERO	ARBRE	WELLE	SHAFT			
8	01018800	1	SCATOLA	CARTER	GEHAEUSE	GEARBOX			
9	68098600	1	TAPPO	BOUCHON	STOPFEN	PLUG			
10	10048100	1	COPPIA CONICA	COUPLE CONIQUE	KEGELRADTRIEB.	BEVEL GEAR PAIR			
11	67009400	1	CUSCINETTO	ROULEMENT	LAGER	BEARING	30210		
12	80017000		GUARNIZIONE	GARNITURE	DICHTUNG	SEAL	Sp. 0,2		
12	80017005		GUARNIZIONE	GARNITURE	DICHTUNG	SEAL	Sp. 0,5		
13	10048200	1	FLANGIA	BRIDE	FLANSCH	FLANGE			
14	60017900	4	VITE	VIS	SCHRAUBE	SCREW	TE 10 x 25		
15	61001500	4	RONDELLA	RONDELLE	SCHEIBE	WASHER	ø 10		
16	67018400	1	CUSCINETTO	ROULEMENT	LAGER	BEARING	6212		
17	31090700	1	ALBERO	ARBRE	WELLE	SHAFT			
18	66000800	2	PARAOLIO	JOINT D'ETAU CHEITE	DICHTRING	OIL SEAL	50 x 80 x 10		
19	80017100		GUARNIZIONE	GARNITURE	DICHTUNG	SEAL	Sp. 0,2		
19	80017105		GUARNIZIONE	GARNITURE	DICHTUNG	SEAL	Sp. 0,5		
20	60019700	4	VITE	VIS	SCHRAUBE	SCREW	TE 12 x 1,5 x 30		
21	60007400	6	VITE	VIS	SCHRAUBE	SCREW	TE 12 x 1,5 x 35		
22	62010500	6	DADO	ECROU	MUTTER	NUT	M 12 x 1,5 AUTOBLOCC.		
23	01018900	1	FLANGIA	BRIDE	FLANSCH	FLANGE			
24	60041400	6	VITE	VIS	SCHRAUBE	SCREW	TCEI 12 x 1,5 x 30		

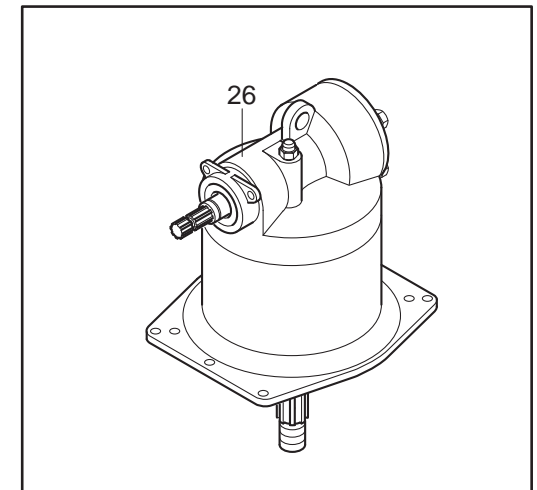
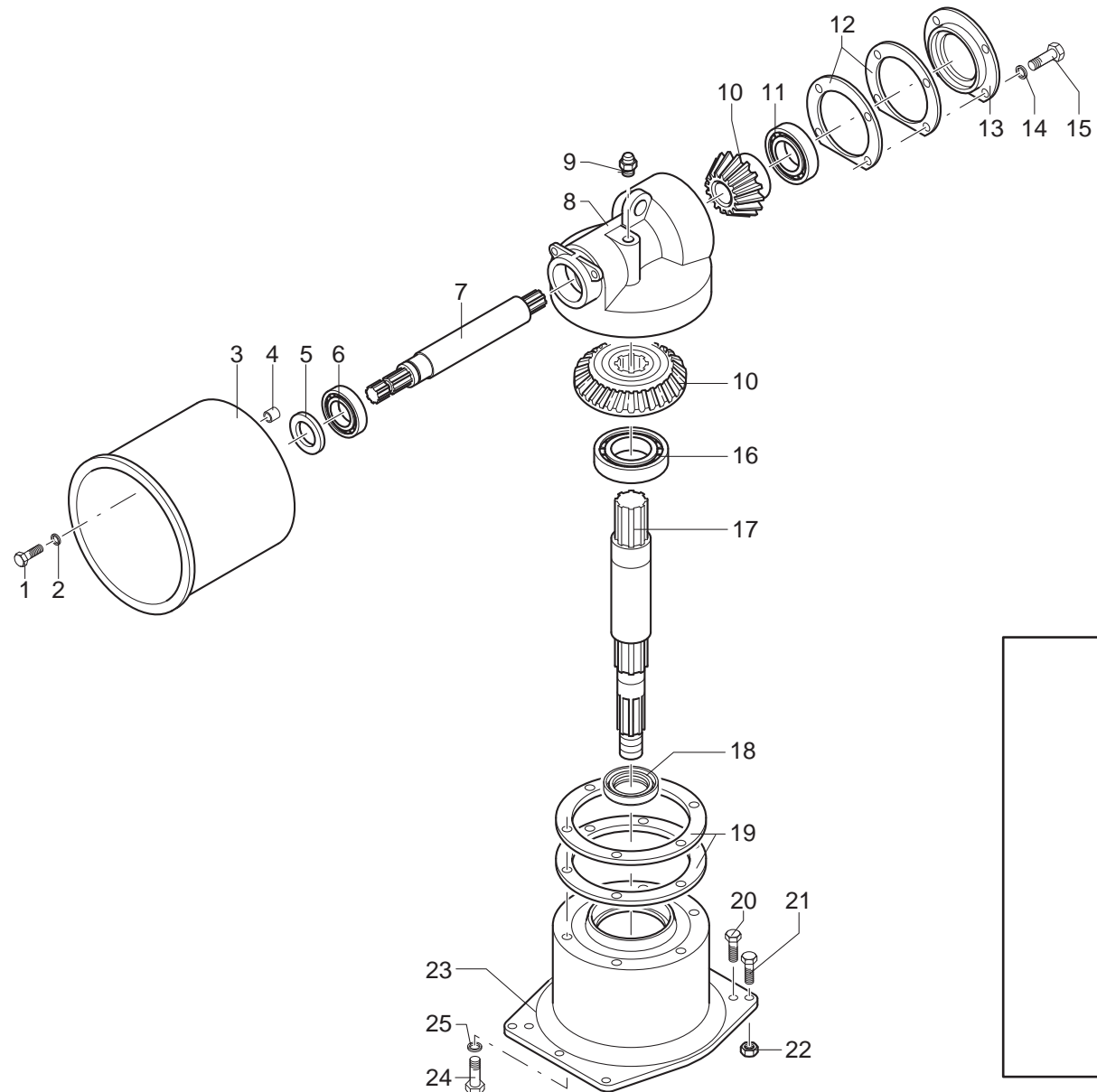

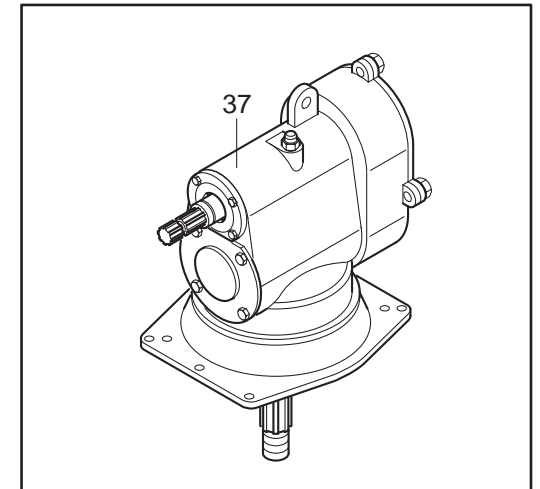
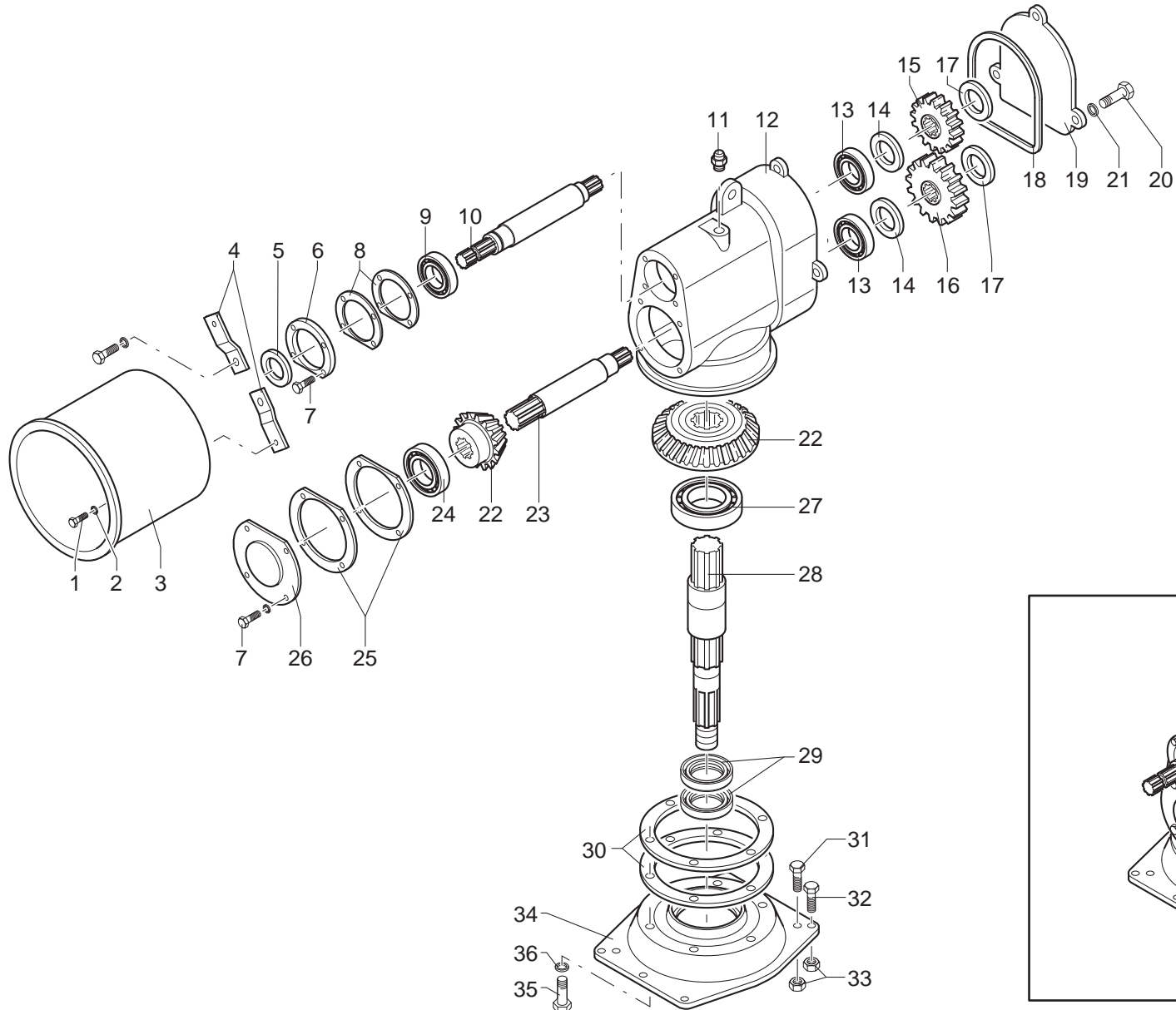

MURATORI ME 22 C

TAV. 4.1

POS.	N° CODICE	Q.	DESCRIZIONE	DESIGNATION	BENENNUNG	DESCRIPTION	DESIGNAZIONE	Da matr. De nr. serie Vom Seriennr. From serial nr.	Fino matr. Jusqu'au nr. serie Bis Seriennr. Up to serial nr.
1	60015100	2	VITE	VIS	SCHRAUBE	SCREW	TE 8 x 16		
2	61006200	2	RONDELLA	RONDELLE	SCHEIBE	WASHER	PIANA øi 9 øe 24		
3	68077000	1	PROTEZIONE	PROTECTION	SCHUTZ	GUARD			
4	30198000	2	SUPPORTO	SUPPORT	HALTERUNG	SUPPORT			
5	66012200	1	PARAOLIO	JOINT D'ETAU CHEITE	DICHTRING	OIL SEAL	35 x 62 x 10		
6	10048300	1	FLANGIA	BRIDE	FLANSCH	FLANGE			
7	60021300	8	VITE	VIS	SCHRAUBE	SCREW	TE 10 x 30		
8	80017200		GUARNIZIONE	GARNITURE	DICHTUNG	SEAL	Sp. 0,2		
8	80017205		GUARNIZIONE	GARNITURE	DICHTUNG	SEAL	Sp. 0,5		
9	67005500	1	CUSCINETTO	ROULEMENT	LAGER	BEARING	32207		
10	31090800	1	ALBERO	ARBRE	WELLE	SHAFT			
11	68098600	1	TAPPO	BOUCHON	STOPFEN	PLUG			
12	01019000	1	SCATOLA	CARTER	GEHAEUSE	GEARBOX			
13	67005500	2	CUSCINETTO	ROULEMENT	LAGER	BEARING	32207		
14	32186100	2	DISTANZIALE	ENTRETOISE	DISTANZSTUECCK	SPACER			
15	31091100	1	INGRANAGGIO	PIGNON	ZAHNRAD	GEAR	Z 19		
16	31091200	1	INGRANAGGIO	PIGNON	ZAHNRAD	GEAR	Z 21		
17	63000600	2	ANELLO ELASTICO	ARRETOIR	SPANNRING	SNAP-RING	ø 35 E		
18	80017300	1	GUARNIZIONE	GARNITURE	DICHTUNG	SEAL			
19	03003400	1	COPERCHIO	COUVERCLE	DECKEL	COVER			
20	60017900	3	VITE	VIS	SCHRAUBE	SCREW	TE 10 x 25		
21	61004900	3	RONDELLA	RONDELLE	SCHEIBE	WASHER	PIANA ø 10		
22	10048100	1	COPPIA CONICA	COUPLE CONIQUE	KEGELRADTRIEB.	BEVEL GEAR PAIR			
23	31090900	1	ALBERO	ARBRE	WELLE	SHAFT			
24	67009400	1	CUSCINETTO	ROULEMENT	LAGER	BEARING	30210		
25	80017000		GUARNIZIONE	GARNITURE	DICHTUNG	SEAL	Sp. 0,2		

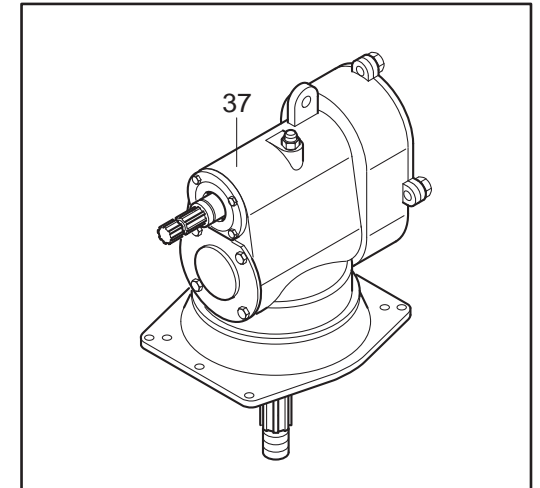
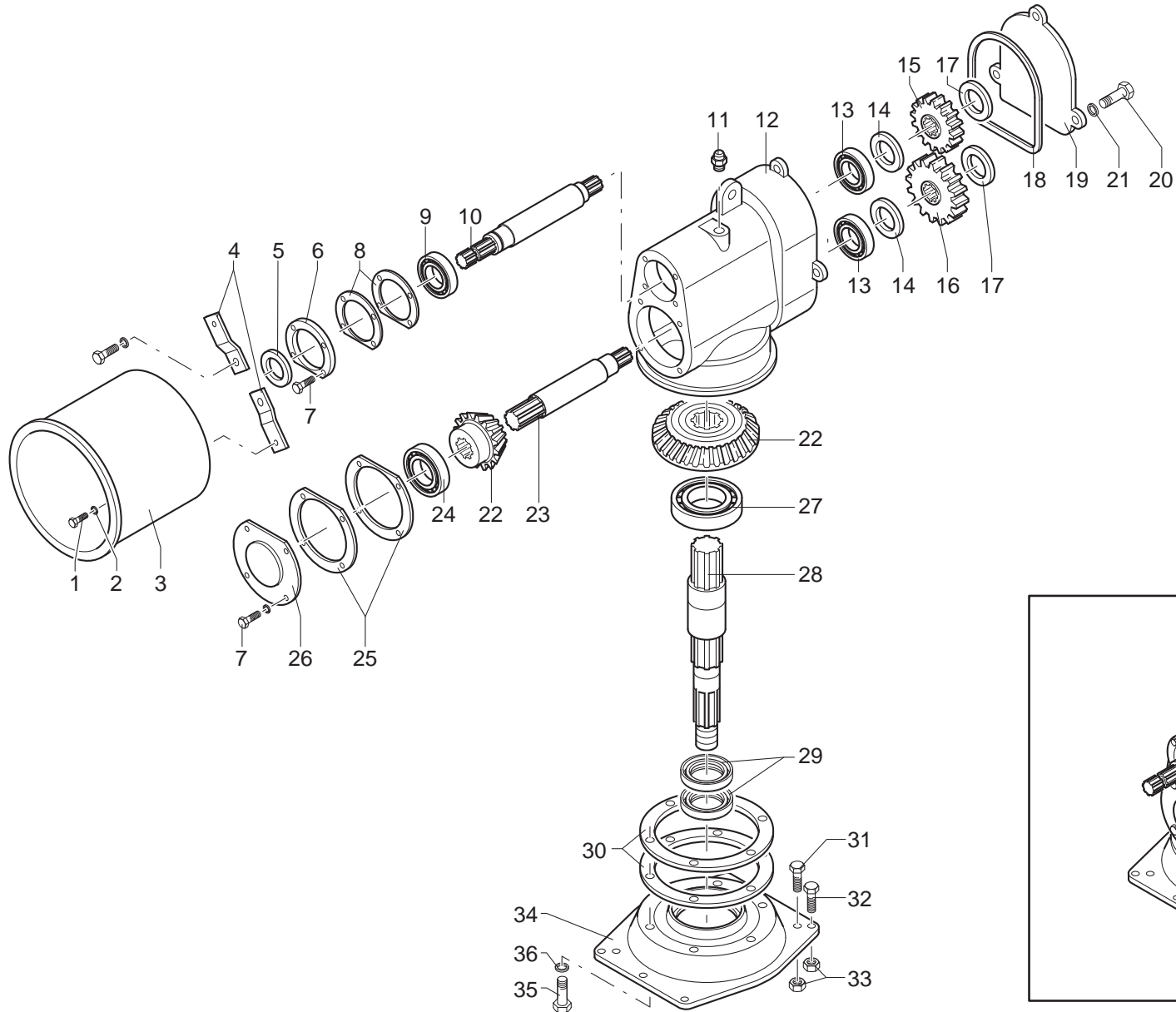



GRUPPO RULLO POSTERIORE
SATZ HINTERE WALZE

ENSEMBLE ROULEAU ARRIERE
KIT REAR ROLLER

TAV. 5.0

ME 22
ME 22 C

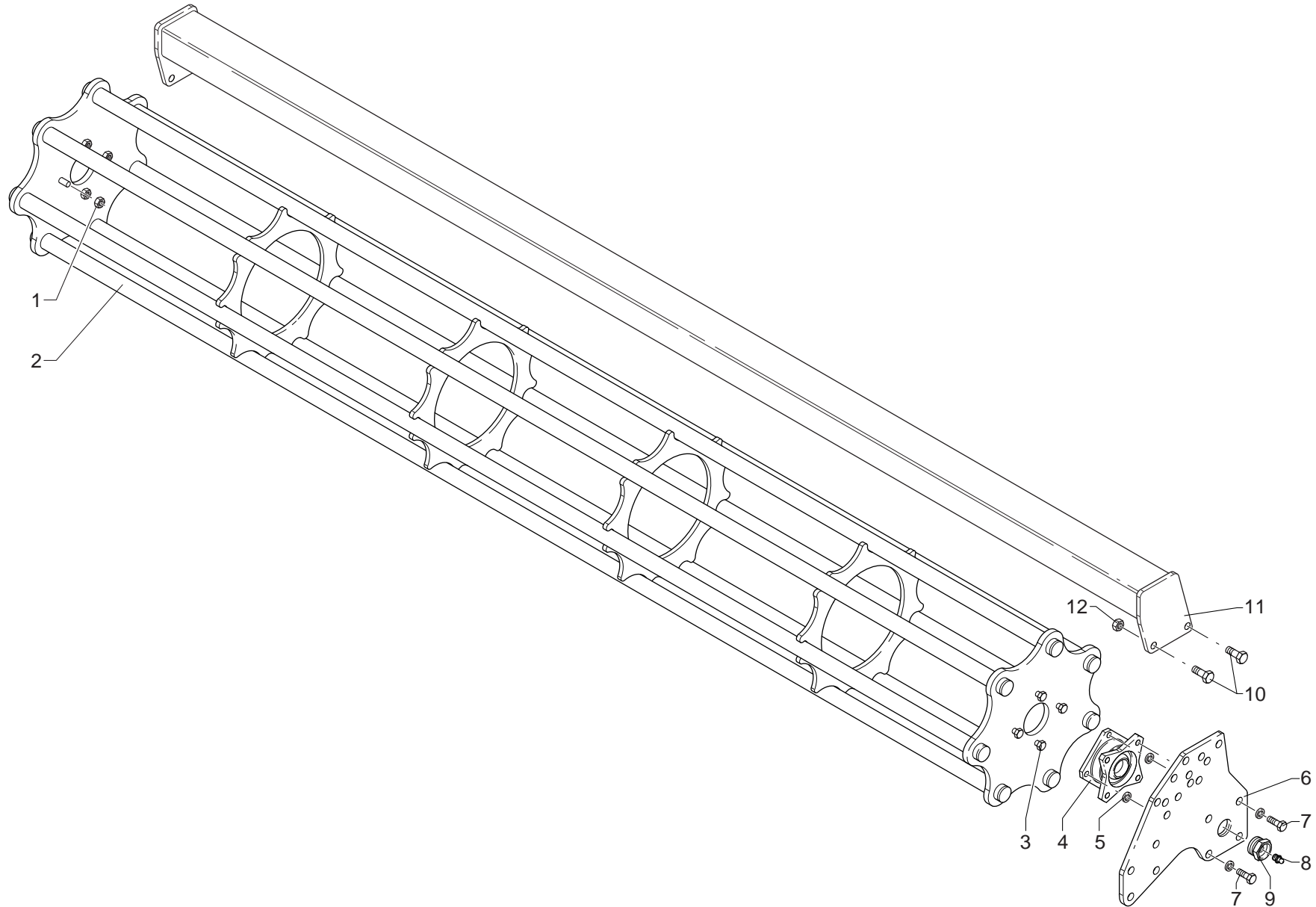

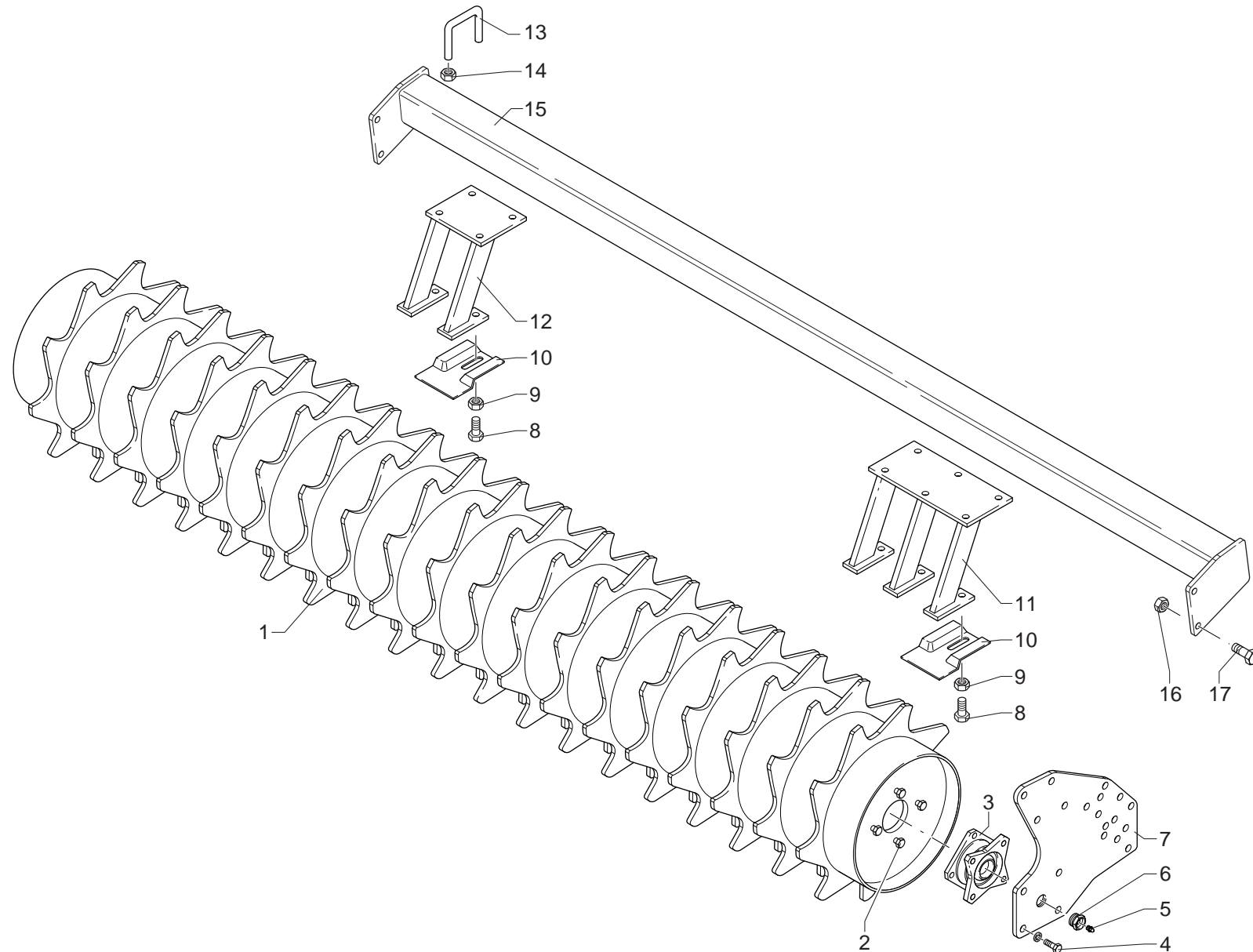

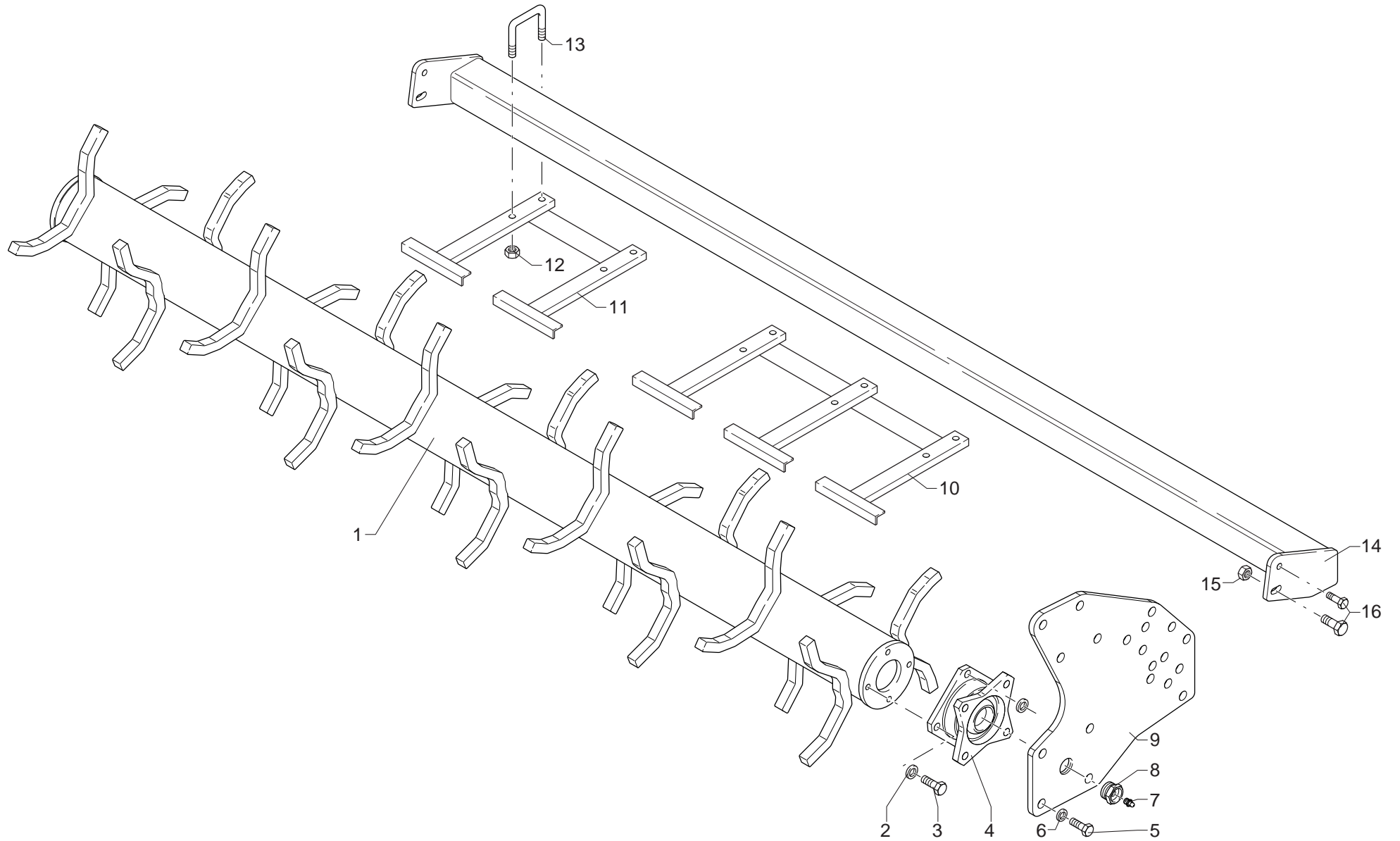

MURATORI ME 22 - ME 22 C

TAV. 5.2

POS.	N° CODICE	Q.	DESCRIZIONE	DESIGNATION	BENENNUNG	DESCRIPTION	DESIGNAZIONE	Da matr. De nr. serie Vom Seriennr. From serial nr.	Fino matr. Jusqu'au nr. serie Bis Seriennr. Up to serial nr.
1	42072600	1	RULLO PUNTONI	ROULEAU A POINTES	SPITZENWALZE	SPIKED ROLLER	130		
1	42072700	1	RULLO PUNTONI	ROULEAU A POINTES	SPITZENWALZE	SPIKED ROLLER	150		
1	42072800	1	RULLO PUNTONI	ROULEAU A POINTES	SPITZENWALZE	SPIKED ROLLER	170		
1	42072900	1	RULLO PUNTONI	ROULEAU A POINTES	SPITZENWALZE	SPIKED ROLLER	200		
1	42073000	1	RULLO PUNTONI	ROULEAU A POINTES	SPITZENWALZE	SPIKED ROLLER	250		
2	61001400	8	RONDELLA	RONDELLE	SCHEIBE	WASHER	ø 12 GROWER		
3	60021200	8	VITE	VIS	SCHRAUBE	SCREW	TE 12 x 35 UNI 5739		
4	45145800	2	SUPPORTO	SUPPORT	TRAEGER	SUPPORT			
5	60023000	8	VITE	VIS	SCHRAUBE	SCREW	TE 12 x 30 UNI 5739		
6	61001400	8	RONDELLA	RONDELLE	SCHEIBE	WASHER	ø 12 GROWER		
7	64000200	2	INGRASSATORE	GRAISSEUR	SCHMIERNIPPEL	GREASE FITTING			
8	68097300	2	SUPPORTO	SUPPORT	TRAEGER	SUPPORT			
9	39286500	2	FIANCO	FLANC	SEITENWAND	SIDE FRAME			
10	40272800		RASCHIARULLO	GRATTOIR	ABSTREIFER	SCRAPER			
11	40272900		RASCHIARULLO	GRATTOIR	ABSTREIFER	SCRAPER			
12	62010300		DADO	ECROU	MUTTER	NUT	M 10 x 1,25 AUTOBLOCC.		
13	38024700		CAVALLOTTO	ARRETOIR	KLEMMSTUECK	UBOLT			
14	40273500	1	TELAIO	CHASSIS	RAHMEN	FRAME	130		
14	40273600	1	TELAIO	CHASSIS	RAHMEN	FRAME	150		
14	40273700	1	TELAIO	CHASSIS	RAHMEN	FRAME	170		
14	40273800	1	TELAIO	CHASSIS	RAHMEN	FRAME	200		
14	40272400	1	TELAIO	CHASSIS	RAHMEN	FRAME	250		
15	62010800	4	DADO	ECROU	MUTTER	NUT	M 14 x 2 AUTOBLOCC.		
16	60023200	4	VITE	VIS	SCHRAUBE	SCREW	TE 14 x 35 UNI 5739		

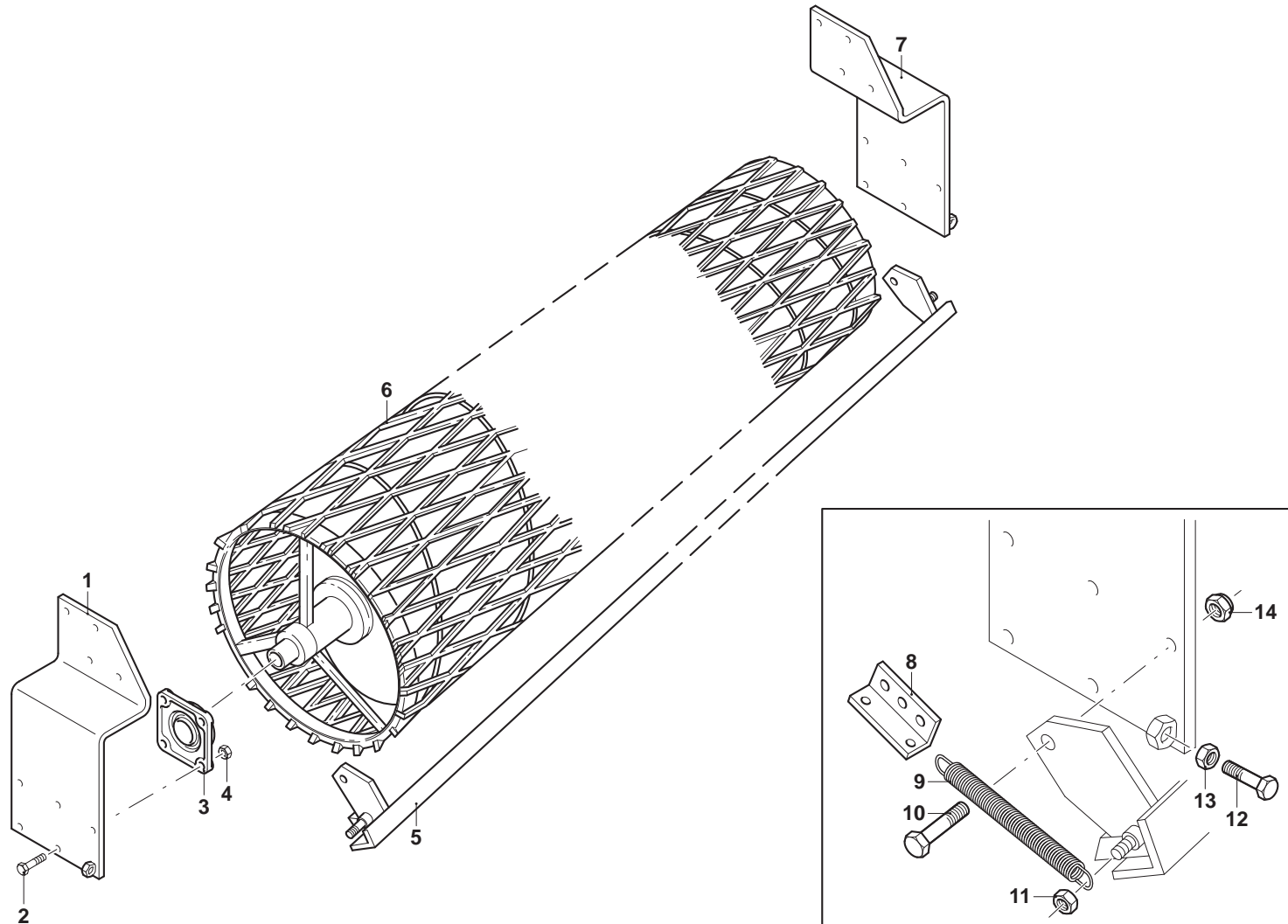

MURATORI ME 22 - ME 22 C
TAV. 5.3

POS.	N° CODICE	Q.	DESCRIZIONE	DESIGNATION	BENENNUNG	DESCRIPTION	DESIGNAZIONE	Da matr.	Fino matr.
								De nr. serie Vom Seriennr. From serial nr.	Jusqu'au nr. serie Bis Seriennr. Up to serial nr.
1	40284900	1	STAFFA SX	BRIDE (G)	BUEGEL (LINKS)	BRACKET (LH)	130-190		
1	40265400	1	STAFFA SX	BRIDE (G)	BUEGEL (LINKS)	BRACKET (LH)	200		
1	40306500	1	STAFFA SX	BRIDE (G)	BUEGEL (LINKS)	BRACKET (LH)	250		
2	60031400	8	VITE	VIS	SCHRAUBE	SCREW	TE 14 x 45 UNI 5739		
3	67009800	2	SUPPORTO	SUPPORT	TRAEGER	SUPPORT	UCF 207		
4	62010800	8	DADO	ECROU	MUTTER	NUT	M 14 x 2 AUTOBLOCC.		
5	40307200	1	RASCHIARULLO	GRATTOIR	ABSTREIFER	SCRAPER	130		
5	40285100	1	RASCHIARULLO	GRATTOIR	ABSTREIFER	SCRAPER	150		
5	40230700	1	RASCHIARULLO	GRATTOIR	ABSTREIFER	SCRAPER	170		
5	40230800	1	RASCHIARULLO	GRATTOIR	ABSTREIFER	SCRAPER	190-200		
5	40248000	1	RASCHIARULLO	GRATTOIR	ABSTREIFER	SCRAPER	250		
6	42081700	1	RULLO	ROULEAU	WALZE	ROLLER	130		
6	42076300	1	RULLO	ROULEAU	WALZE	ROLLER	150		
6	42067300	1	RULLO	ROULEAU	WALZE	ROLLER	170		
6	42067400	1	RULLO	ROULEAU	WALZE	ROLLER	190-200		
6	42068400	1	RULLO	ROULEAU	WALZE	ROLLER	250		
7	40285000	1	STAFFA DX	BRIDE (D)	BUEGEL (RECHTS)	BRACKET (RH)	130-190		
7	40265500	1	STAFFA DX	BRIDE (D)	BUEGEL (RECHTS)	BRACKET (RH)	200		
7	40306600	1	STAFFA DX	BRIDE (D)	BUEGEL (RECHTS)	BRACKET (RH)	250		
8	34027500	2	REGOLAZIONE	REGULATEUR	MECHANISCHER	REGLER GOVERNOR			
9	68085500	2	MOLLA	RESSORT	FEDER	SPRING			
10	60023200	2	VITE	VIS	SCHRAUBE	SCREW	TE 14 x 35 UNI 5739 8.8 ZNT		
11	62010400	2	DADO	ECROU	MUTTER	NUT	M 10 AUTOBLOCC.		
12	60022200	2	VITE	VIS	SCHRAUBE	SCREW	TE 10 x 50 UNI 5739		
13	62003200	2	DADO	ECROU	MUTTER	NUT	M 10 x 1,5 UNI 5588		
14	62010800	2	DADO	ECROU	MUTTER	NUT	M 14 AUTOBLOCC.		

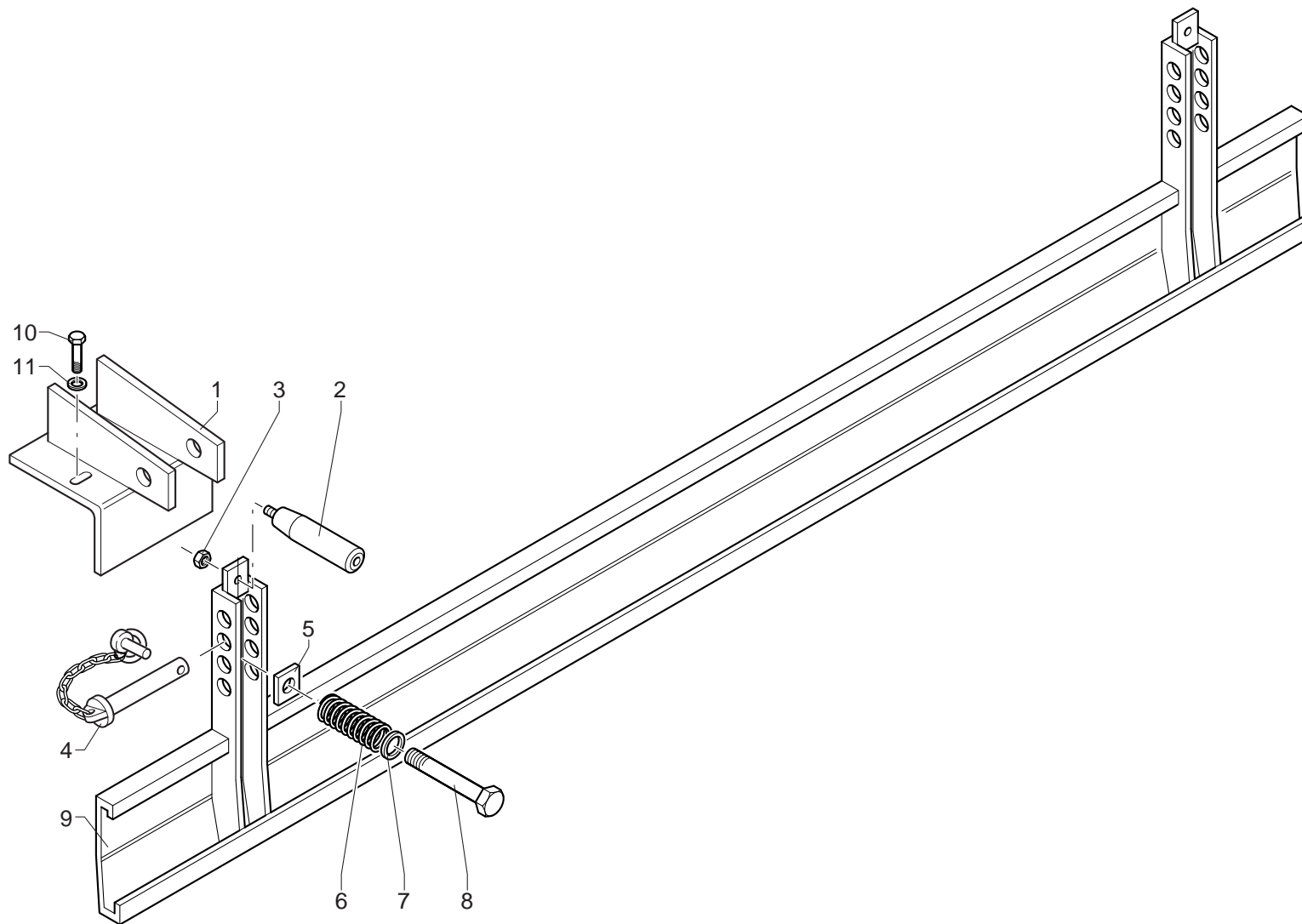

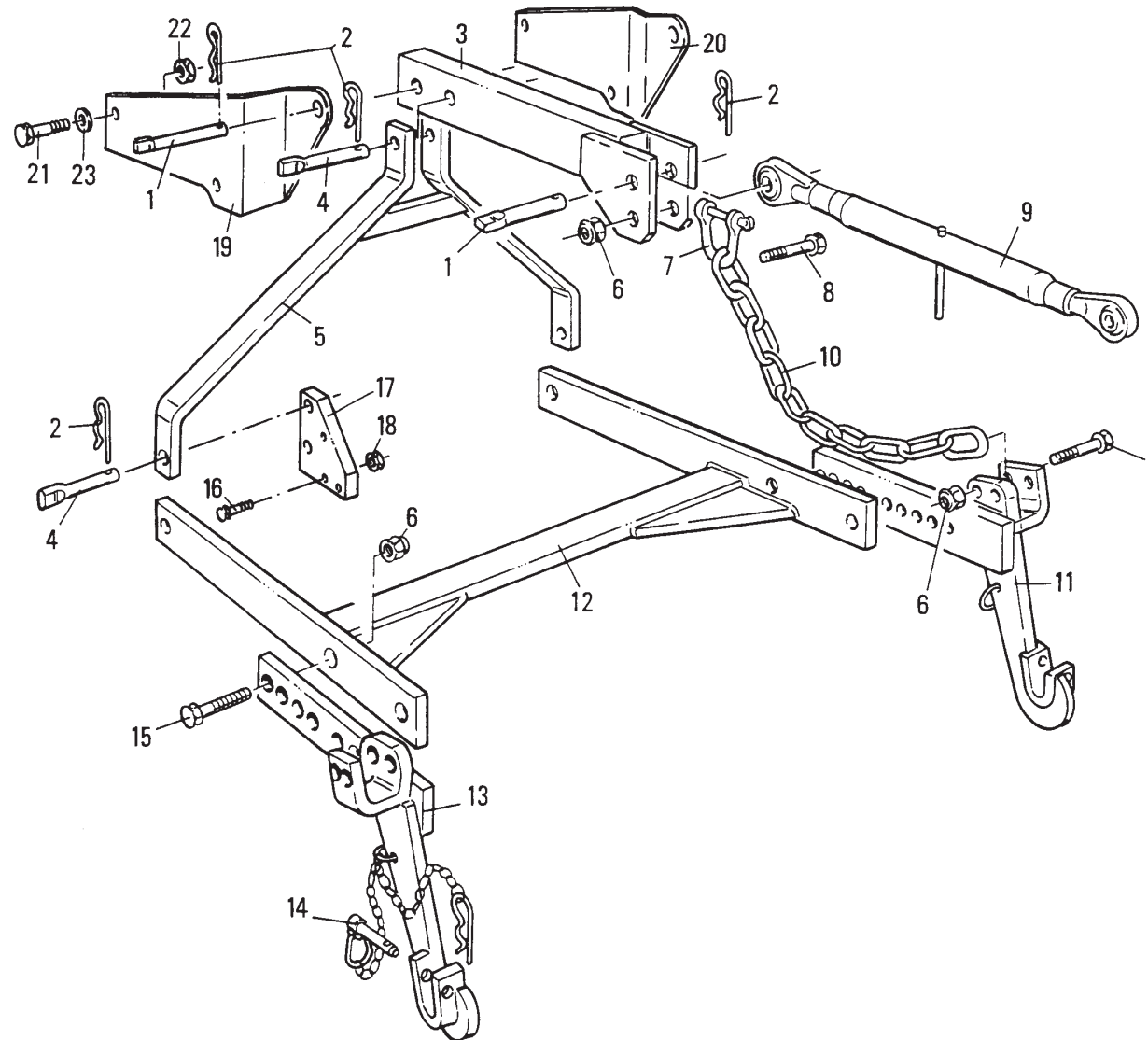

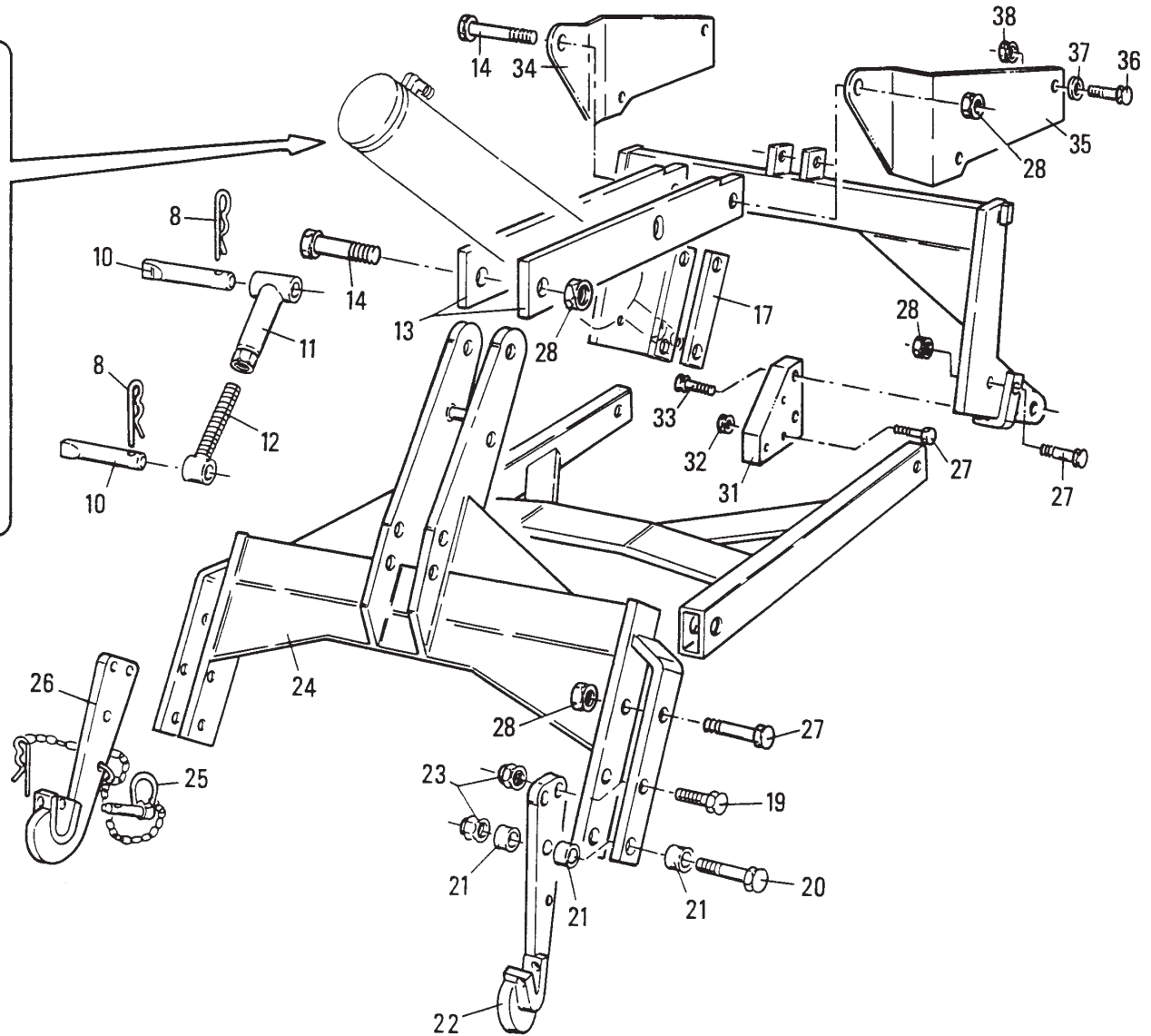
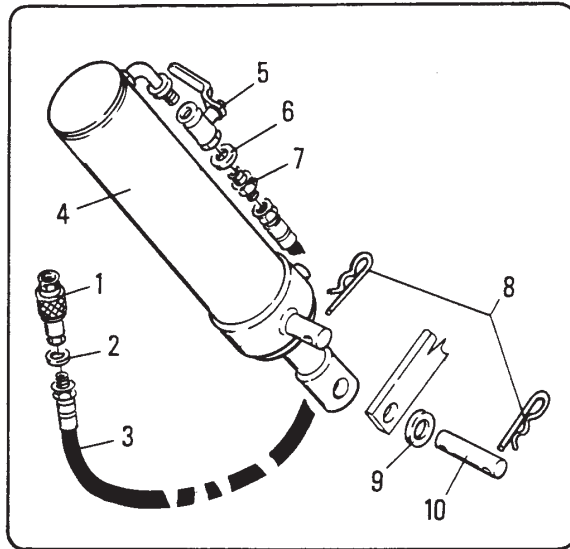

MURATORI ME 22 - ME 22 C (250)

TAV. 8.0

POS.	N° CODICE	Q.	DESCRIZIONE	DESIGNATION	BENENNUNG	DESCRIPTION	DESIGNAZIONE	Da matr. De nr. serie Vom Seriennr. From serial nr.	Fino matr. Jusqu'au nr. serie Bis Seriennr. Up to serial nr.
1	68043500	1	ATTACCO RAPIDO	ATTELAGE RAPIDE	SCHNELLKUPPLUNG	QUICKLINKAGE			
2	61005700	1	RONDELLA	RONDELLE	SCHEIBE	WASHER	RAME 1/2"		
3	68077700	1	TUBO	TUBE	ROHR	TUBE			
4	68077300	1	CILINDRO	CYLINDRE	ZYLINDER	CYLINDER			
5	68077600	1	RUBINETTO	ROBINET	HAHN	TAP			
6	61005600	2	RONDELLA	RONDELLE	SCHEIBE	WASHER	RAME 3/8"		
7	68077500	1	NIPPLO	RACCORD	NIPPEL	NIPPLE	3/8"		
8	64001000	4	COPIGLIA	COUPILLE	SPLINT	COTTER PIN	AR Ø 5		
9	61003900	2	RONDELLA	RONDELLE	SCHEIBE	WASHER	PIANA 50 x 27 UNI 6592		
10	38022500	3	PERNO	PIVOT	BOLZEN	PIN	L= 115		
11	40205900	1	AGGANCIO	CROCHET	HAKEN	HOOK			
12	40205800	1	VITE	VIS	SCHRAUBE	SCREW			
13	30157800	2	STAFFA	BRIDE	BUEGEL	BRACKET			
14	60037700	2	VITE	VIS	SCHRAUBE	SCREW	TE 24 x 180 UNI 5737		
15	40205500	1	TELAIO	CHASSIS	RAHMEN	FRAME			
17	30157700	2	TIRANTE	TIRANT	STANGE	TIEROD			
18	40205600	1	TELAIO	CHASSIS	RAHMEN	FRAME			
19	60035000	2	VITE	VIS	SCHRAUBE	SCREW	TE 18 x 50 UNI 5739		
20	60034900	2	VITE	VIS	SCHRAUBE	SCREW	TE 18 x 120 UNI 5737		
21	32155200	6	BOCCOLA	DOUILLE	BUECHSE	BUSHING			
22	40212600	1	STAFFA DX	BRIDE (D)	BUEGEL(RECHTS)	BRACKET (RH)			
23	62011200	4	DADO	ECROU	MUTTER	NUT	M 18 x 2,5 AUTOBLOCC.		
24	40205700	1	TELAIO	CHASSIS	RAHMEN	FRAME			
25	68077400	2	PERNO	PIVOT	BOLZEN	PIN			
26	40212700	1	STAFFA SX	BRIDE (G)	BUEGEL (LINKS)	BRACKET (LH)			
27	60037600	4	VITE	VIS	SCHRAUBE	SCREW	TE 24 x 120 UNI 5737		

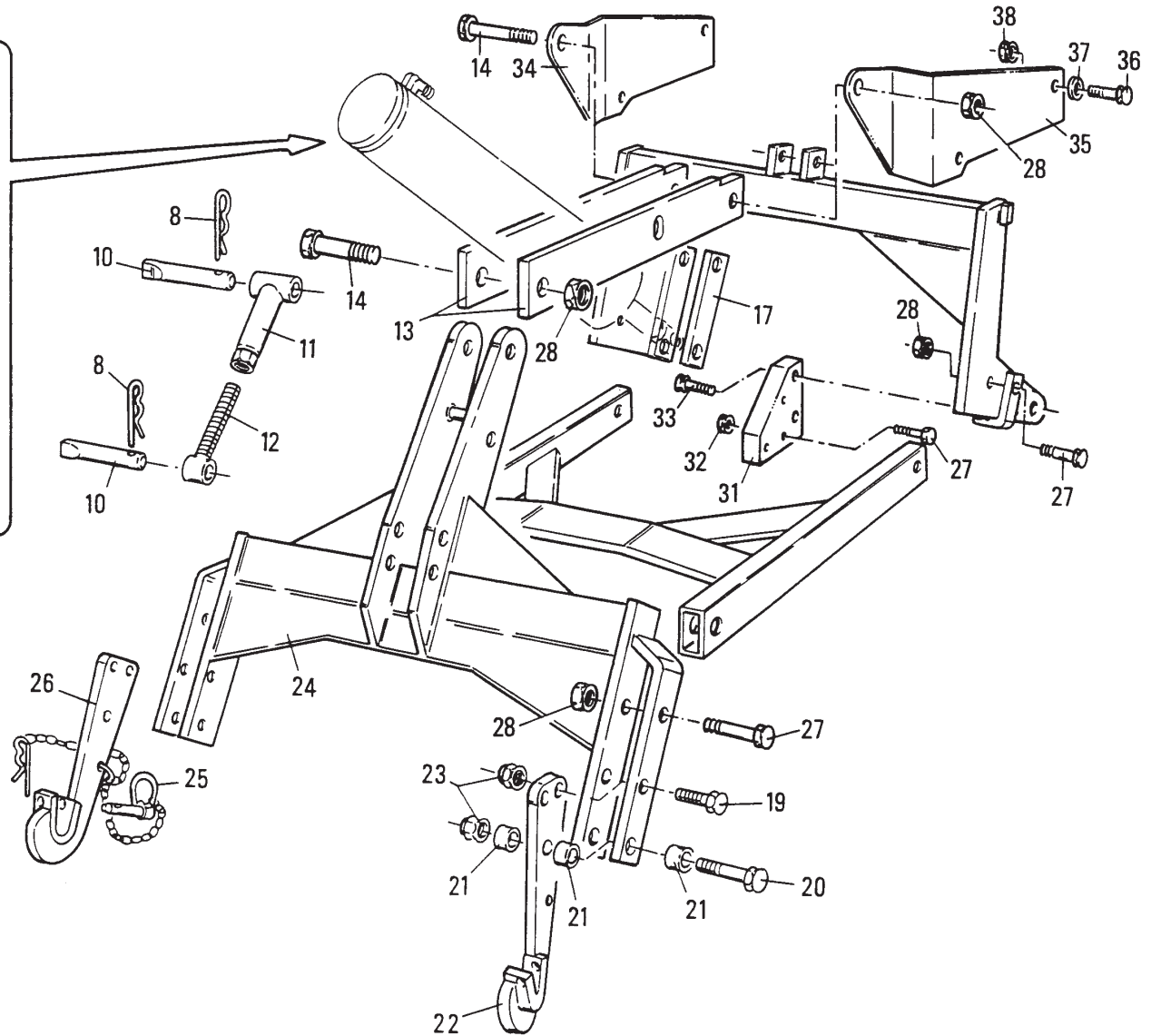
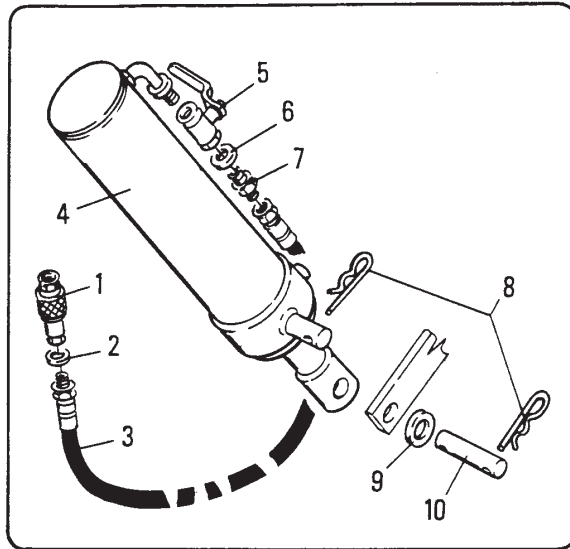

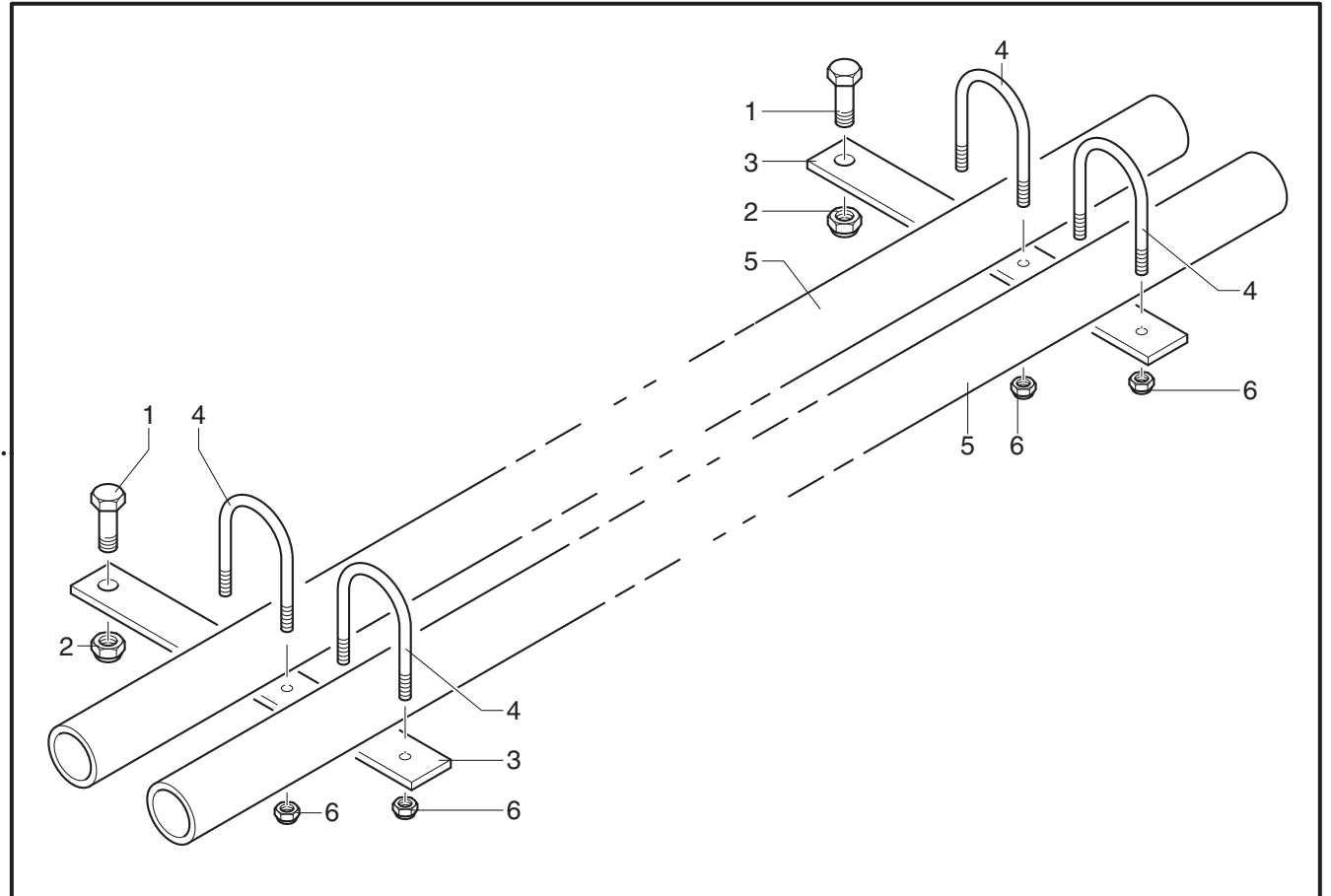
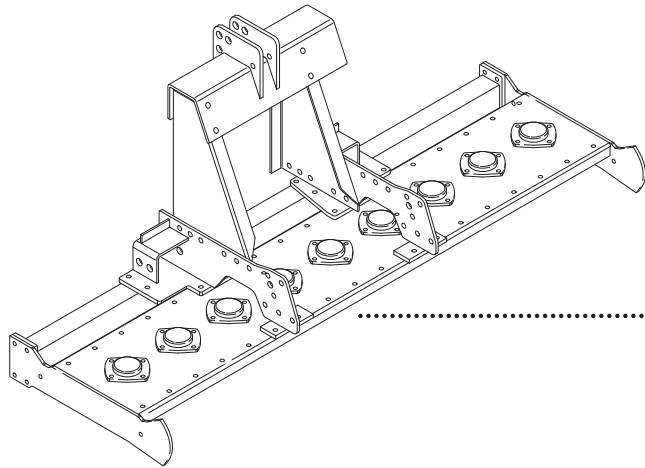

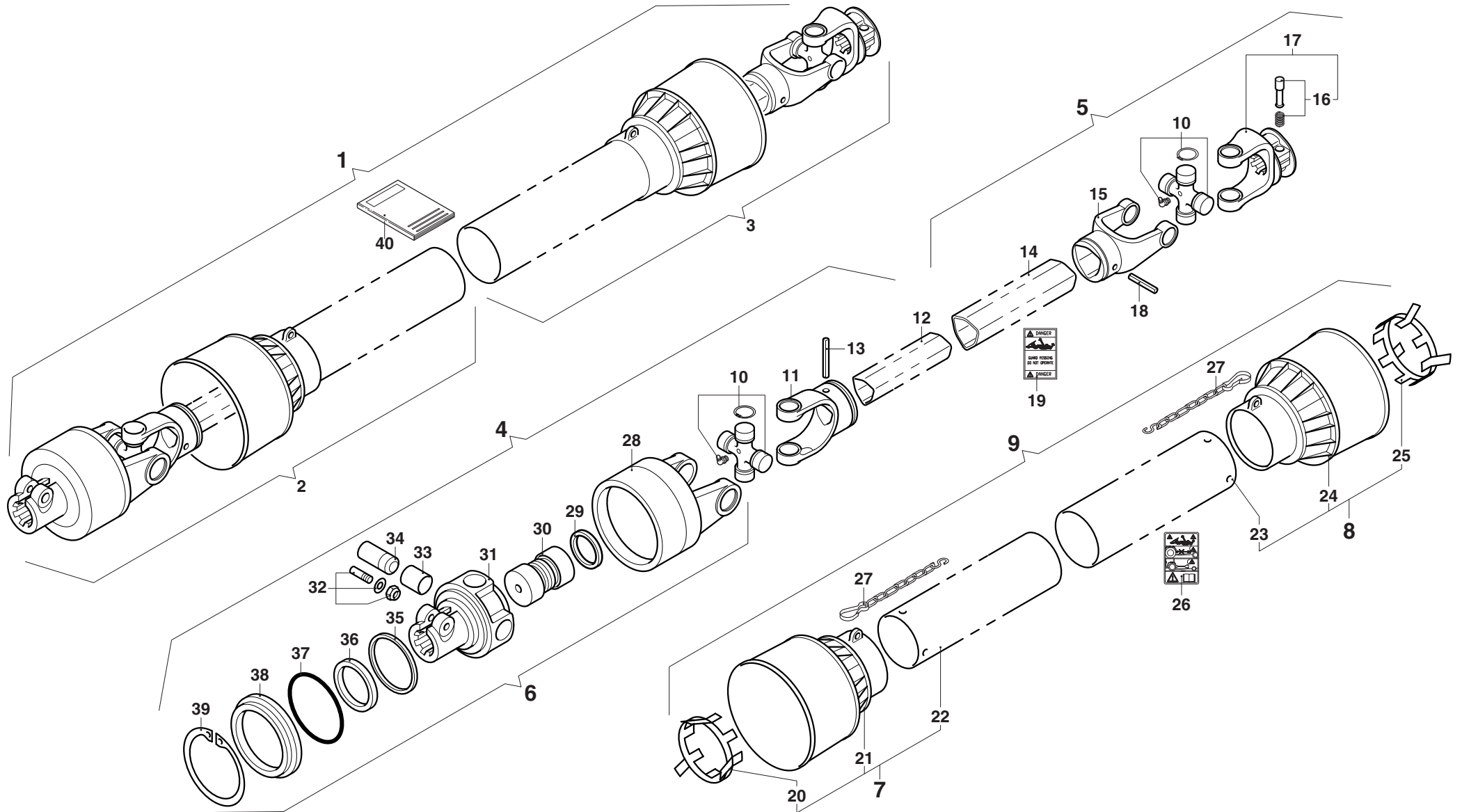

MURATORI ME 22 (130-250)

TAV. 10.0

POS.	N° CODICE	Q.	DESCRIZIONE	DESIGNATION	BENENNUNG	DESCRIPTION	DESIGNAZIONE	Da matr. De nr. serie Vom Seriennr. From serial nr.	Fino matr. Jusqu'au nr. serie Bis Seriennr. Up to serial nr.
1	A6085FLR	1	ALBERO CARDANICO COMPLETO	ARBRE A JOINTS DE CARDAN	KARDANWELLE	PTO SHAFT			
2	7116061CE19A	1	SEMIALBERO INTERNO	DEMI-ARBRE INTERIEUR	INNENHALBWELLE	INTERNAL HALF SHAFT			
3	7E16061CE007	1	SEMIALBERO ESTERNO	DEMI-ARBRE EXTERIEUR	AUSSENHALBWELLE	EXTERNAL HALF SHAFT			
4	71160610019A	1	SEMIALBERO INTERNO	DEMI-ARBRE INTERIEUR	INNENHALBWELLE	INTERNAL HALF SHAFT			
5	7E1606100007	1	SEMIALBERO ESTERNO	DEMI-ARBRE EXTERIEUR	AUSSENHALBWELLE	EXTERNAL HALF SHAFT			
6	6WH161003R	1	FRIZIONE	EMBRAYAGE	KUPPLUNG	CLUTCH			
7	5FI6061FFCE	1	PROTEZIONE	PROTECTION	SCHUTZ	GUARD			
8	5FE6061FFCE	1	PROTEZIONE INTERNA	PROTECTION INTERIEURE	INNENSCHUTZ	INTERNAL GUARD			
9	5F06061FFCE	1	PROTEZIONE ESTERNA	PROTECTION EXTERIEURE	AUSSENSCHUTZ	EXTERNAL GUARD			
10	4120H0011R30	2	CROCIERA	CROISILLON	KREUZSTUECK	SPIDER			
11	204066852	1	FORCELLA	FOURCHE	GABEL	YOKE			
12	225160445	1	TUBO INTERNO	TUBE INTERIEUR	INNENROHR	INTERNAL TUBE			
13	341043000R10	1	SPINA	GOUPILLE	STIFT	PIN			
14	225210445	1	TUBO ESTERNO	TUBE EXTERIEUR	AUSSENROHR	EXTERNAL TUBE			
15	204066851	1	FORCELLA	FOURCHE	GABEL	YOKE			
16	341043000R10	1	PULSANTE	BOUTON	DRUCKKNOPF	PUSH BOTTON			
17	5070H0355	1	FORCELLA	FOURCHE	GABEL	YOKE			
18	341042000R10	1	SPINA	GOUPILLE	STIFT	PIN			
19	399143000	1	ETICHETTA	ETIQUETE	ETIKETT	LABEL			
20	255060006R02	1	GHIERA	FRETTE	NUTMUTTER	RING NUT			
21	517050030	1	CUFFIA	CAPOUCHON	HAUBE	GUARD			
22	236820386	1	TUBO INTERNO	TUBE INTERIEUR	INNENROHR	INTERNAL TUBE			
23	236830386	1	TUBO ESTERNO	TUBE EXTERIEUR	AUSSENROHR	EXTERNAL TUBE			
24	517050030	1	CUFFIA	CAPOUCHON	HAUBE	GUARD			
25	255060005R02	1	GHIERA	FRETTE	NUTMUTTER	RING NUT			

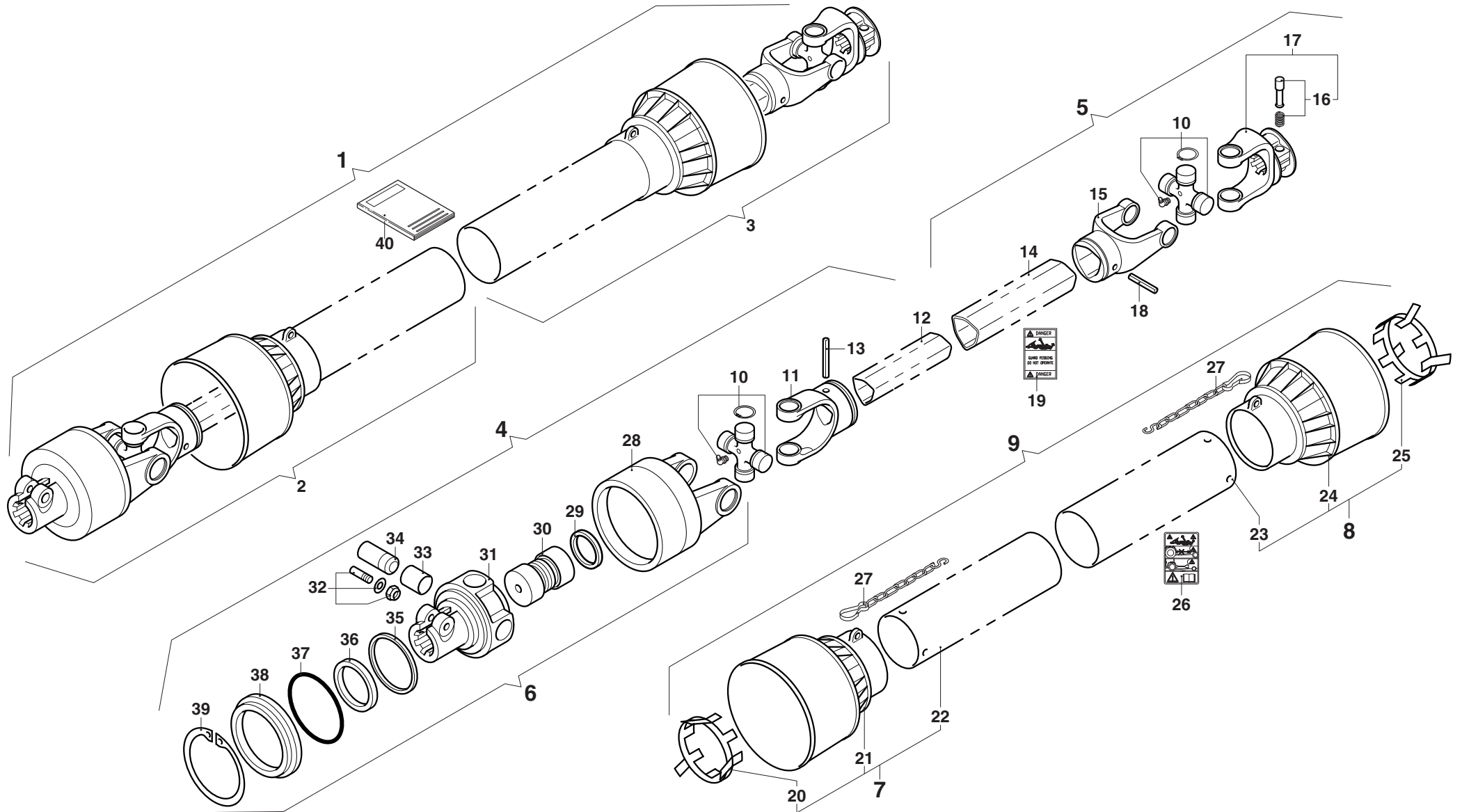

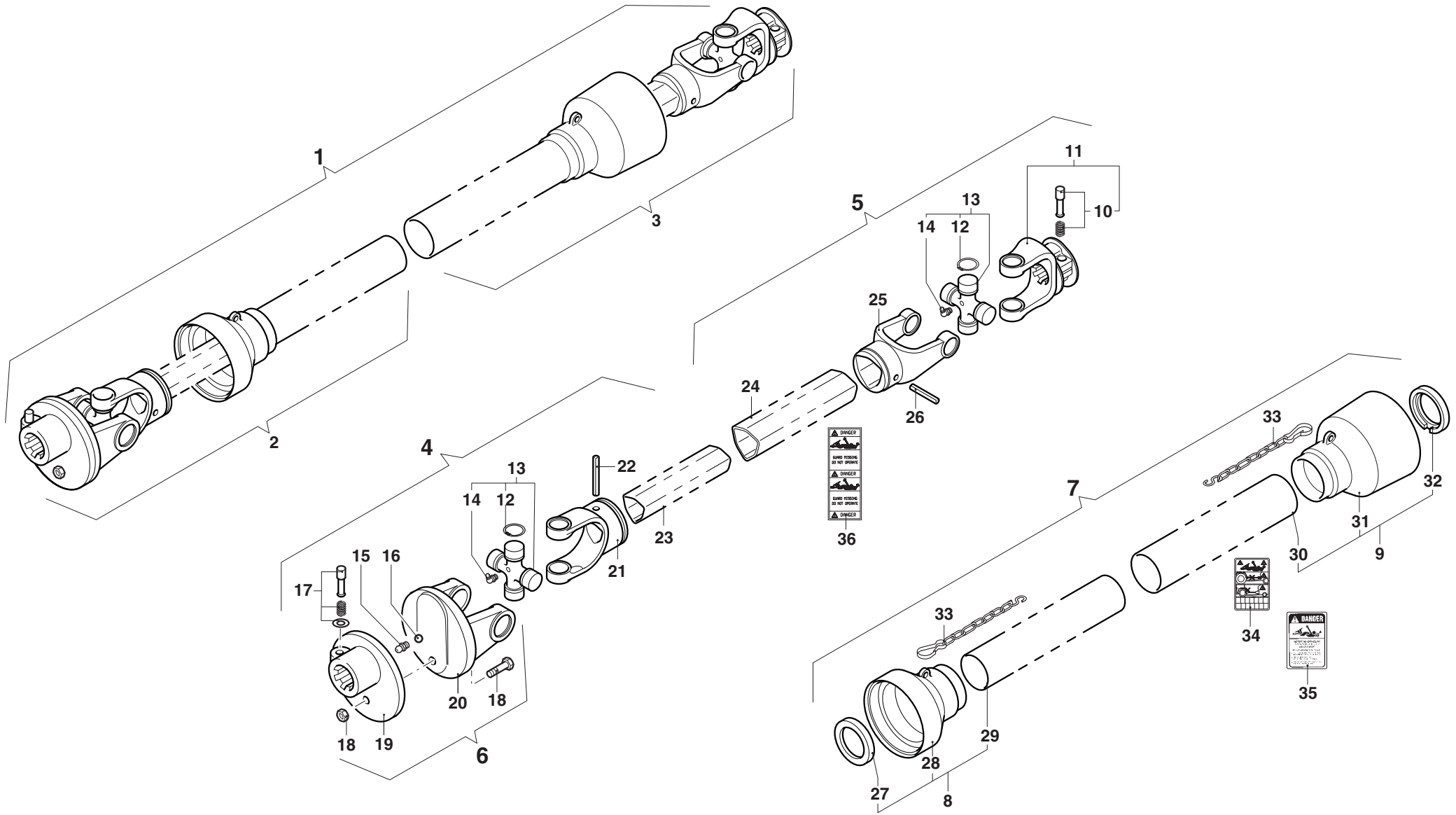

MURATORI ME 22 (130-250)

TAV. 11.0

POS.	N° CODICE	Q.	DESCRIZIONE	DESIGNATION	BENENNUNG	DESCRIPTION	DESIGNAZIONE	Da matr. De nr. serie Vom Seriennr. From serial nr.	Fino matr. Jusqu'au nr. serie Bis Seriennr. Up to serial nr.
1	AB6085FSB	1	ALBERO CARDANICO COMPLETO	ARBRE A JOINTS DE CARDAN	KARDANWELLE	PTO SHAFT			
2	B6085B1098	1	SEMIALBERO INTERNO	DEMI-ARBRE INTERIEUR	INNENHALBWELLE	INTERNAL HALF SHAFT			
3	B6085B2	1	SEMIALBERO ESTERNO	DEMI-ARBRE EXTERIEUR	AUSSENHALBWELLE	EXTERNAL HALF SHAFT			
4	B608501098	1	SEMIALBERO INTERNO	DEMI-ARBRE INTERIEUR	INNENHALBWELLE	INTERNAL HALF SHAFT			
5	B608502	1	SEMIALBERO ESTERNO	DEMI-ARBRE EXTERIEUR	AUSSENHALBWELLE	EXTERNAL HALF SHAFT			
6	08806	1	LIMITATORE	LIMITEUR	ANSCHLAG	TRAVEL LIMITER			
7	083B06085	1	PROTEZIONE	PROTECTION	SCHUTZ	GUARD			
8	083B060851	1	PROTEZIONE INTERNA	PROTECTION INTERIEURE	INNENSCHUTZ	INTERNAL GUARD			
9	083B060852	1	PROTEZIONE ESTERNA	PROTECTION EXTERIEURE	AUSSENSCHUTZ	EXTERNAL GUARD			
10	0986014047	1	PULSANTE	BOUTON	DRUCKKNOPF	PUSH BOTTON			
11	0800603	1	FORCELLA	FOURCHE	GABEL	YOKE			
12	08206	8	ANELLO ELASTICO	ARRETOIR	SPANNRING	SNAP-RING			
13	08206	2	CROCIERA	CROISILLON	KREUZSTUECK	SPIDER			
14	09840081002	2	INGRASSATORE	GRAISSEUR	SCHMIERNIPPEL	GREASE FITTING			
15	0984010150	1	INGRASSATORE	GRAISSEUR	SCHMIERNIPPEL	GREASE FITTING			
16	098680516	24	SFERA	BILLE	KUGEL	BALL			
17	0986014075	1	PULSANTE	BOUTON	DRUCKKNOPF	PUSH BOTTON			
18	099010055B	1	BULLONE	BOULON	BOLZEN	BOLT			
19	088966A60	1	MOZZO	MOYEU	NABE	HUB			
20	08896906	1	FORCELLA	FOURCHE	GABEL	YOKE			
21	08006011	1	FORCELLA	FOURCHE	GABEL	YOKE			
22	098701070	1	SPINA	GOUPILLE	STIFT	PIN			
23	09881454100	1	TUBO INTERNO	TUBE INTERIEUR	INNENROHR	INTERNAL TUBE			
24	09881544100	1	TUBO ESTERNO	TUBE EXTERIEUR	AUSSENROHR	EXTERNAL TUBE			
25	08006021	1	FORCELLA	FOURCHE	GABEL	YOKE			

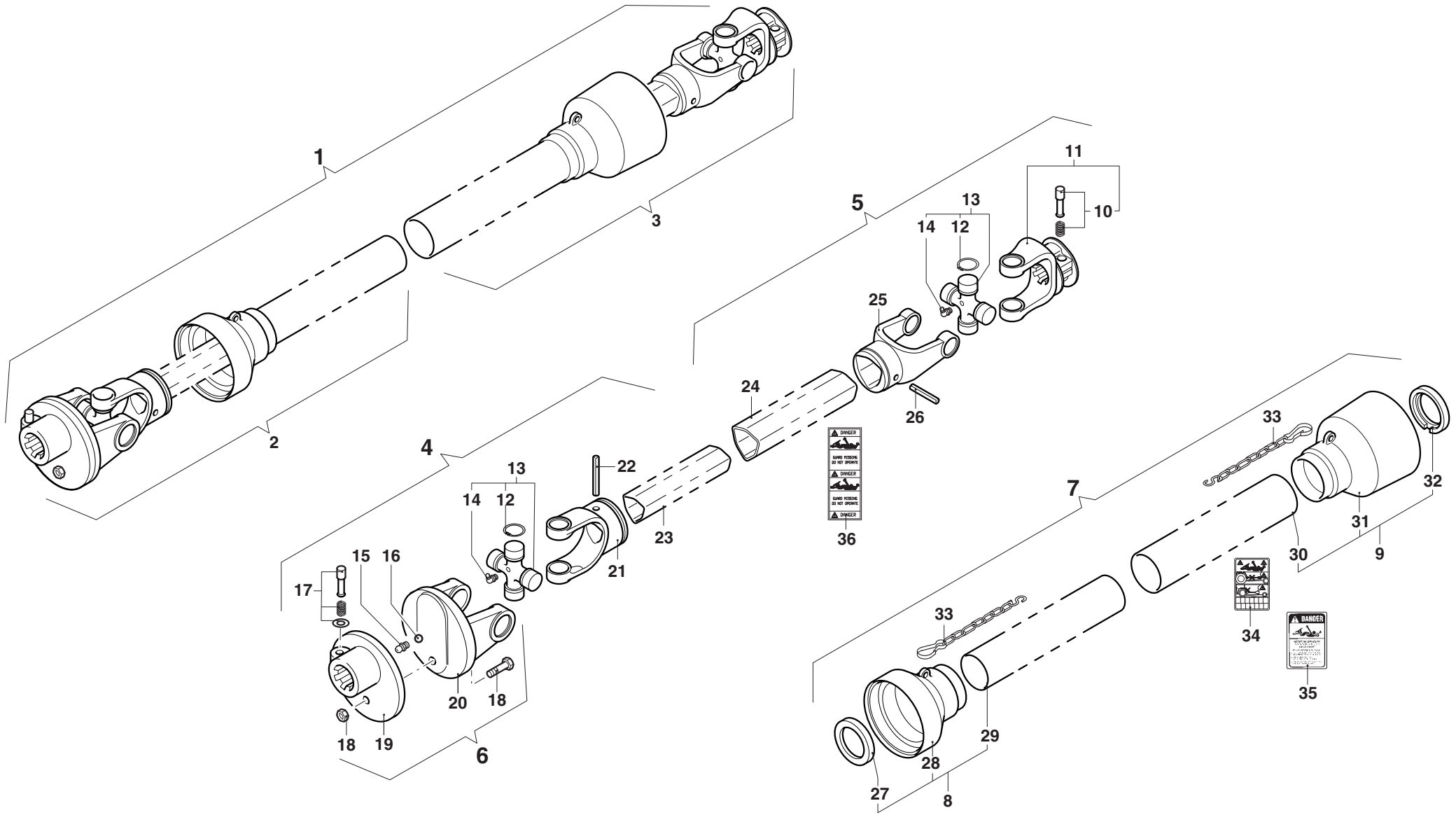

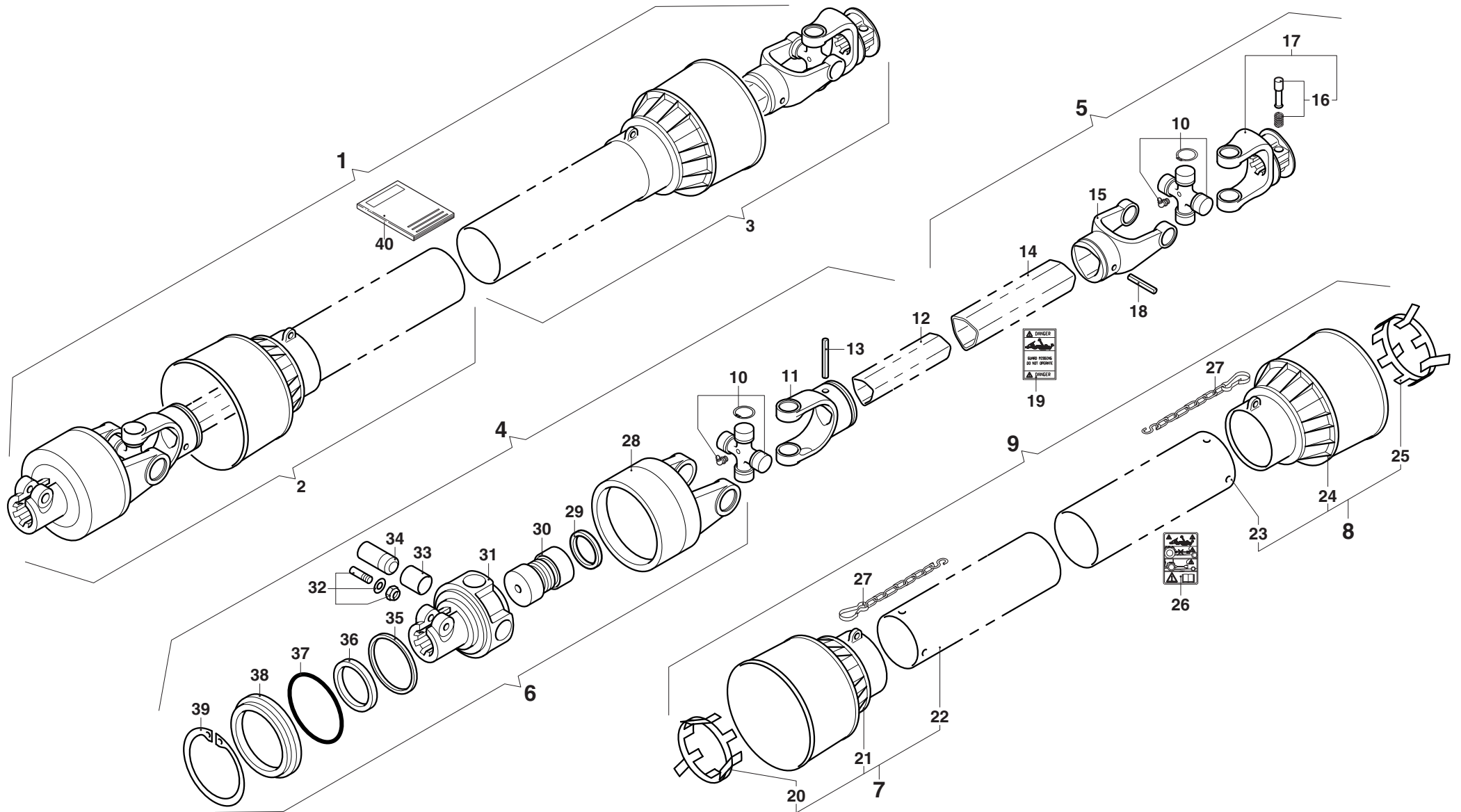

MURATORI ME 22 C (200)
TAV. 12.0

POS.	N° CODICE	Q.	DESCRIZIONE	DESIGNATION	BENENNUNG	DESCRIPTION	DESIGNAZIONE	Da matr. De nr. serie Vom Seriennr. From serial nr.	Fino matr. Jusqu'au nr. serie Bis Seriennr. Up to serial nr.
1	A6085FLR	1	ALBERO CARDANICO COMPLETO	ARBRE A JOINTS DE CARDAN	KARDANWELLE	PTO SHAFT			118795
2	7116061CE19A	1	SEMIALBERO INTERNO	DEMI-ARBRE INTERIEUR	INNENHALBWELLE	INTERNAL HALF SHAFT			118795
3	7E16061CE007	1	SEMIALBERO ESTERNO	DEMI-ARBRE EXTERIEUR	AUSSENHALBWELLE	EXTERNAL HALF SHAFT			118795
4	71160610019A	1	SEMIALBERO INTERNO	DEMI-ARBRE INTERIEUR	INNENHALBWELLE	INTERNAL HALF SHAFT			118795
5	7E1606100007	1	SEMIALBERO ESTERNO	DEMI-ARBRE EXTERIEUR	AUSSENHALBWELLE	EXTERNAL HALF SHAFT			118795
6	6WH161003R	1	FRIZIONE	EMBRAYAGE	KUPPLUNG	CLUTCH			118795
7	5FI6061FFCE	1	PROTEZIONE	PROTECTION	SCHUTZ	GUARD			118795
8	5FE6061FFCE	1	PROTEZIONE INTERNA	PROTECTION INTERIEURE	INNENSCHUTZ	INTERNAL GUARD			118795
9	5F06061FFCE	1	PROTEZIONE ESTERNA	PROTECTION EXTERIEURE	AUSSENSCHUTZ	EXTERNAL GUARD			118795
10	4120H0011R30	2	CROCIERA	CROISILLON	KREUZSTUECK	SPIDER			118795
11	204066852	1	FORCELLA	FOURCHE	GABEL	YOKE			118795
12	225160445	1	TUBO INTERNO	TUBE INTERIEUR	INNENROHR	INTERNAL TUBE			118795
13	341043000R10	1	SPINA	GOUPILLE	STIFT	PIN			118795
14	225210445	1	TUBO ESTERNO	TUBE EXTERIEUR	AUSSENROHR	EXTERNAL TUBE			118795
15	204066851	1	FORCELLA	FOURCHE	GABEL	YOKE			118795
16	341043000R10	1	PULSANTE	BOUTON	DRUCKKNOPF	PUSH BOTTON			118795
17	5070H0355	1	FORCELLA	FOURCHE	GABEL	YOKE			118795
18	341042000R10	1	SPINA	GOUPILLE	STIFT	PIN			118795
19	399143000	1	ETICHETTA	ETIQUETE	ETIKETT	LABEL			118795
20	255060006R02	1	GHIERA	FRETTE	NUTMUTTER	RING NUT			118795
21	517050030	1	CUFFIA	CAPOUCHON	HAUBE	GUARD			118795
22	236820386	1	TUBO INTERNO	TUBE INTERIEUR	INNENROHR	INTERNAL TUBE			118795
23	236830386	1	TUBO ESTERNO	TUBE EXTERIEUR	AUSSENROHR	EXTERNAL TUBE			118795
24	517050030	1	CUFFIA	CAPOUCHON	HAUBE	GUARD			118795
25	255060005R02	1	GHIERA	FRETTE	NUTMUTTER	RING NUT			118795

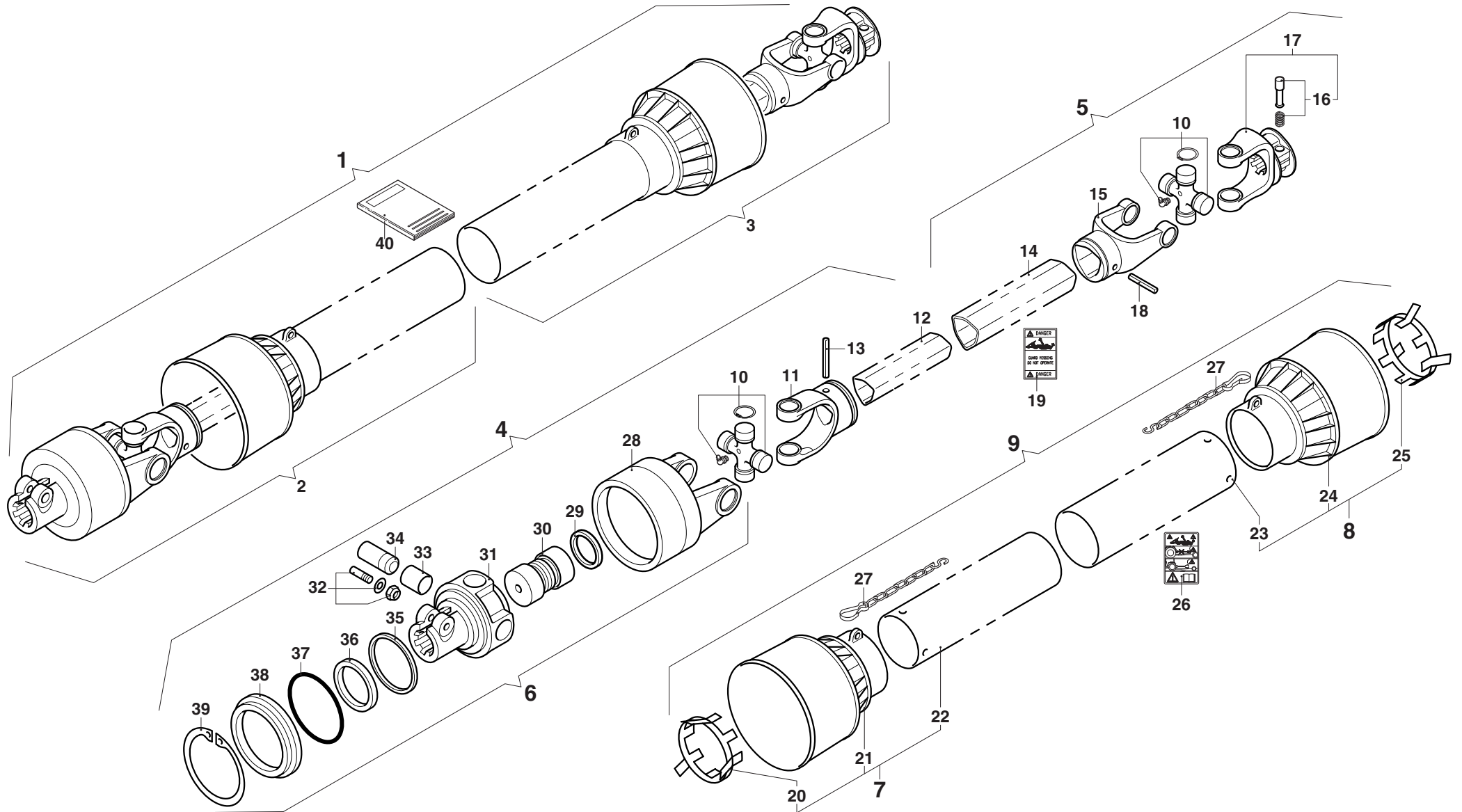

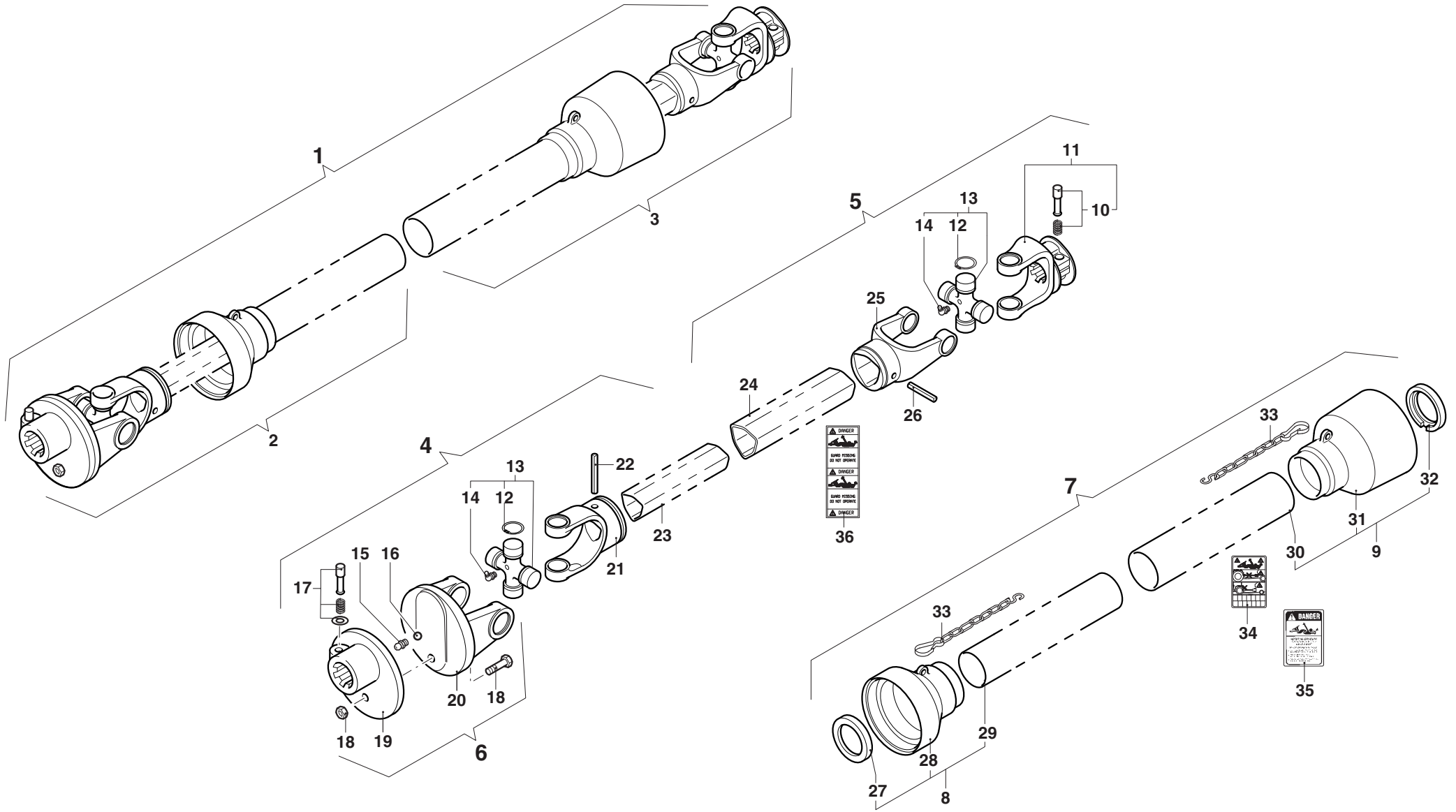

MURATORI ME 22 C (200)

TAV. 13.0

POS.	N° CODICE	Q.	DESCRIZIONE	DESIGNATION	BENENNUNG	DESCRIPTION	DESIGNAZIONE	Da matr. De nr. serie Vom Seriennr. From serial nr.	Fino matr. Jusqu'au nr. serie Bis Seriennr. Up to serial nr.
1	AB6085FSB	1	ALBERO CARDANICO COMPLETO	ARBRE A JOINTS DE CARDAN	KARDANWELLE	PTO SHAFT			118795
2	B6085B1098	1	SEMIALBERO INTERNO	DEMI-ARBRE INTERIEUR	INNENHALBWELLE	INTERNAL HALF SHAFT			118795
3	B6085B2	1	SEMIALBERO ESTERNO	DEMI-ARBRE EXTERIEUR	AUSSENHALBWELLE	EXTERNAL HALF SHAFT			118795
4	B608501098	1	SEMIALBERO INTERNO	DEMI-ARBRE INTERIEUR	INNENHALBWELLE	INTERNAL HALF SHAFT			118795
5	B608502	1	SEMIALBERO ESTERNO	DEMI-ARBRE EXTERIEUR	AUSSENHALBWELLE	EXTERNAL HALF SHAFT			118795
6	08806	1	LIMITATORE	LIMITEUR	ANSCHLAG	TRAVEL LIMITER			118795
7	083B06085	1	PROTEZIONE	PROTECTION	SCHUTZ	GUARD			118795
8	083B060851	1	PROTEZIONE INTERNA	PROTECTION INTERIEURE	INNENSCHUTZ	INTERNAL GUARD			118795
9	083B060852	1	PROTEZIONE ESTERNA	PROTECTION EXTERIEURE	AUSSENSCHUTZ	EXTERNAL GUARD			118795
10	0986014047	1	PULSANTE	BOUTON	DRUCKKNOPF	PUSH BOTTON			118795
11	0800603	1	FORCELLA	FOURCHE	GABEL	YOKE			118795
12	08206	8	ANELLO ELASTICO	ARRETOIR	SPANNRING	SNAP-RING			118795
13	08206	2	CROCIERA	CROISILLON	KREUZSTUECK	SPIDER			118795
14	09840081002	2	INGRASSATORE	GRAISSEUR	SCHMIERNIPPEL	GREASE FITTING			118795
15	0984010150	1	INGRASSATORE	GRAISSEUR	SCHMIERNIPPEL	GREASE FITTING			118795
16	098680516	24	SFERA	BILLE	KUGEL	BALL			118795
17	0986014075	1	PULSANTE	BOUTON	DRUCKKNOPF	PUSH BOTTON			118795
18	099010055B	1	BULLONE	BOULON	BOLZEN	BOLT			118795
19	088966A60	1	MOZZO	MOYEU	NABE	HUB			118795
20	08896906	1	FORCELLA	FOURCHE	GABEL	YOKE			118795
21	08006011	1	FORCELLA	FOURCHE	GABEL	YOKE			118795
22	098701070	1	SPINA	GOUPILLE	STIFT	PIN			118795
23	09881454100	1	TUBO INTERNO	TUBE INTERIEUR	INNENROHR	INTERNAL TUBE			118795
24	09881544100	1	TUBO ESTERNO	TUBE EXTERIEUR	AUSSENROHR	EXTERNAL TUBE			118795
25	08006021	1	FORCELLA	FOURCHE	GABEL	YOKE			118795

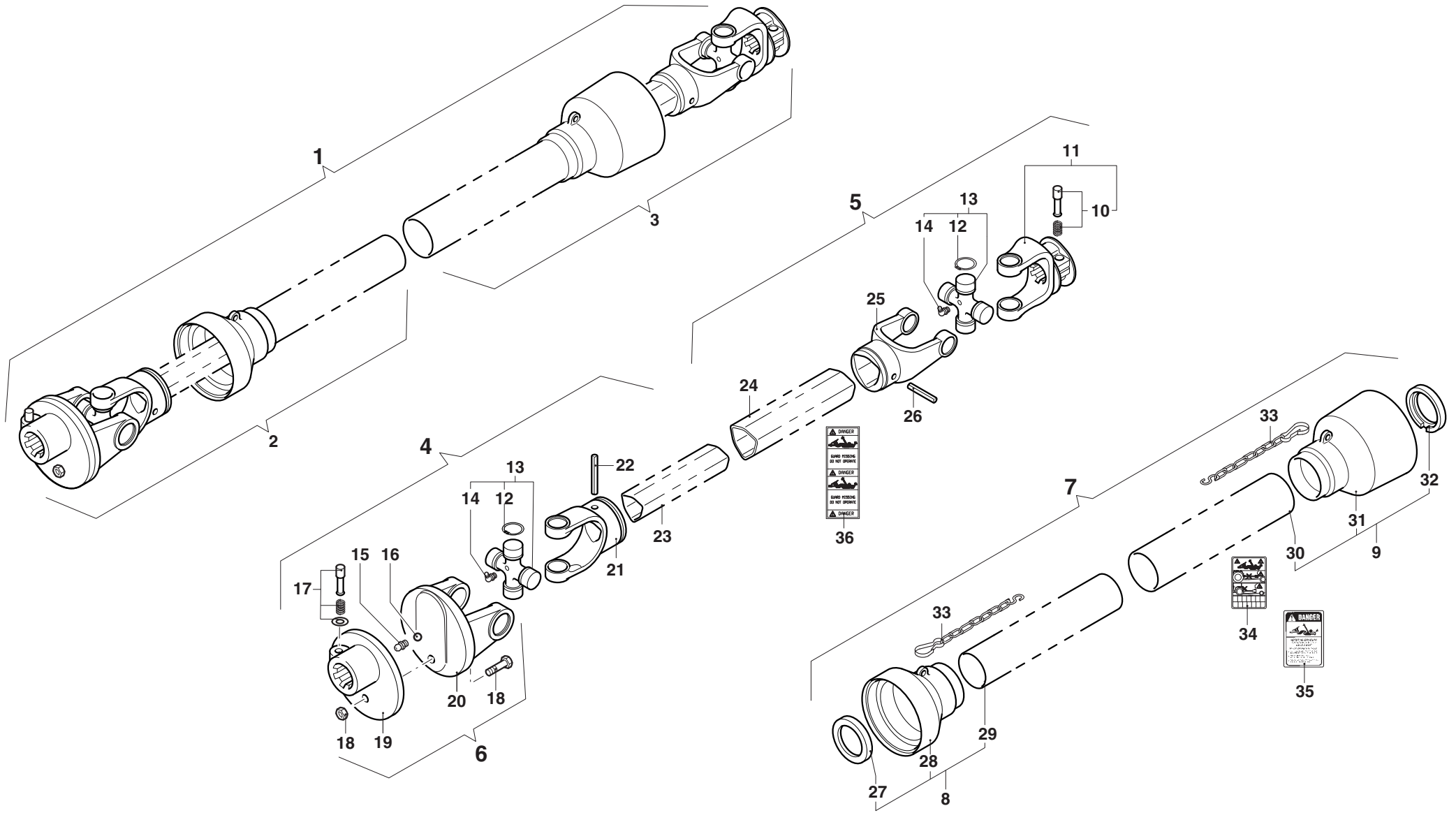

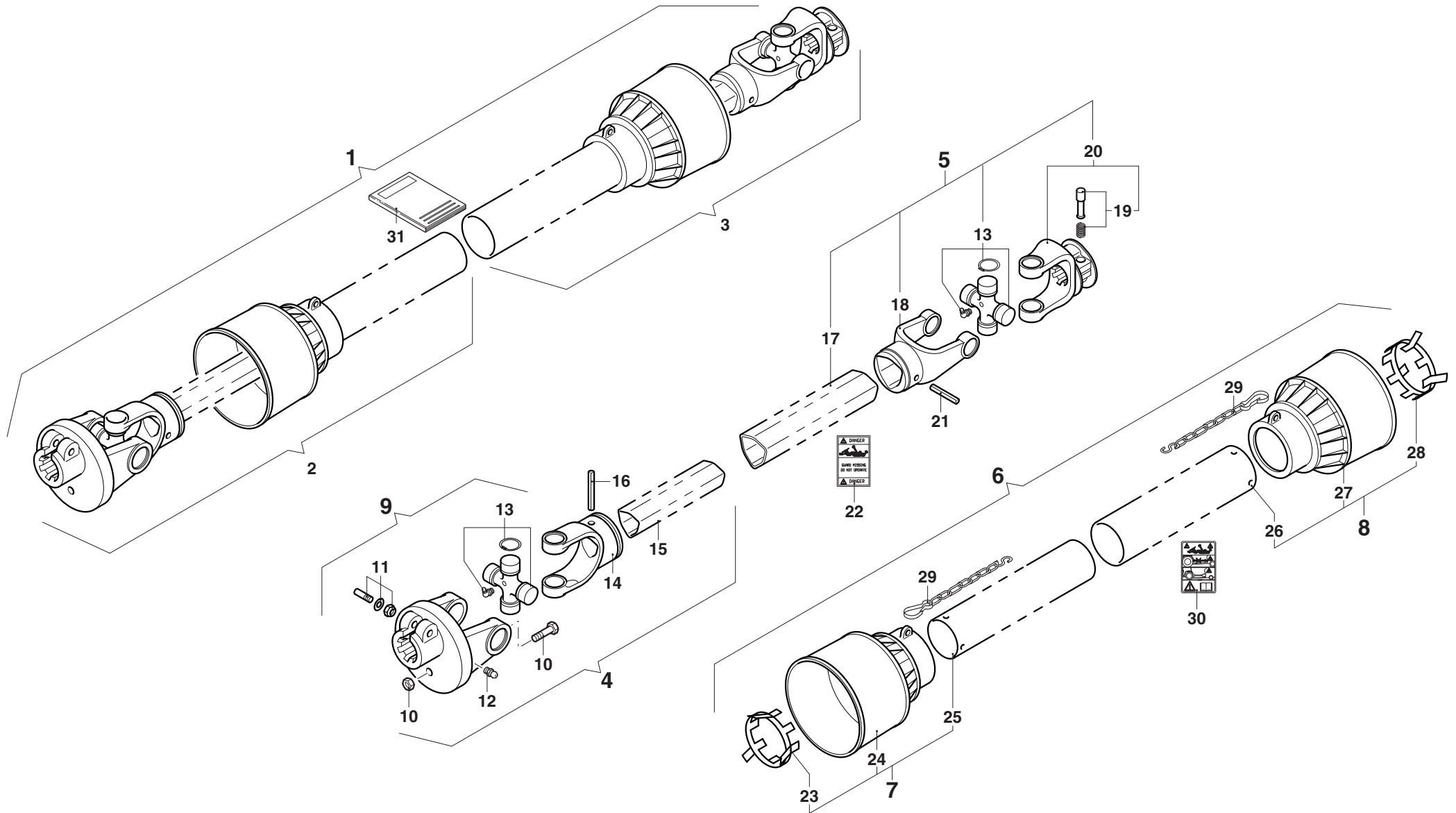

MURATORI ME 22 C (250)

TAV. 14.0

POS.	N° CODICE	Q.	DESCRIZIONE	DESIGNATION	BENENNUNG	DESCRIPTION	DESIGNAZIONE	Da matr. De nr. serie Vom Seriennr. From serial nr.	Fino matr. Jusqu'au nr. serie Bis Seriennr. Up to serial nr.
1	A809FSBG	1	ALBERO CARDANICO COMPLETO	ARBRE A JOINTS DE CARDAN	KARDANWELLE	PTO SHAFT			118795
2	7118066CE1R5	1	SEMIALBERO INTERNO	DEMI-ARBRE INTERIEUR	INNENHALBWELLE	INTERNAL HALF SHAFT			118795
3	7E18066CE007	1	SEMIALBERO ESTERNO	DEMI-ARBRE EXTERIEUR	AUSSENHALBWELLE	EXTERNAL HALF SHAFT			118795
4	7118066001R5	1	SEMIALBERO INTERNO	DEMI-ARBRE INTERIEUR	INNENHALBWELLE	INTERNAL HALF SHAFT			118795
5	7E1806600007	1	SEMIALBERO ESTERNO	DEMI-ARBRE EXTERIEUR	AUSSENHALBWELLE	EXTERNAL HALF SHAFT			118795
6	5F08066FFCE	1	PROTEZIONE	PROTECTION	SCHUTZ	GUARD			118795
7	5F18066FFCE	1	PROTEZIONE INTERNA	PROTECTION INTERIEURE	INNENSCHUTZ	INTERNAL GUARD			118795
8	5FE8066FFCE	1	PROTEZIONE ESTERNA	PROTECTION EXTERIEURE	AUSSENSCHUTZ	EXTERNAL GUARD			118795
9	6060M0407R	1	FORCELLA	FOURCHE	GABEL	YOKE			118795
10	432000053R05	1	BULLONE	BOULON	BOLZEN	BOLT			118795
11	408000052R02	1	PERNO	PIVOT	BOLZEN	PIN			118795
12	348017000R20	1	INGRASSATORE	GRAISSEUR	SCHMIERNIPPEL	GREASE FITTING			118795
13	4120M0011R20	2	CROCIERA	CROISILLON	KREUZSTUECK	SPIDER			118795
14	204086861	1	FORCELLA	FOURCHE	GABEL	YOKE			118795
15	225690475	1	TUBO INTERNO	TUBE INTERIEUR	INNENROHR	INTERNAL TUBE			118795
16	341055000R10	1	SPINA	GOUPILLE	STIFT	PIN			118795
17	225730475	1	TUBO ESTERNO	TUBE EXTERIEUR	AUSSENROHR	EXTERNAL TUBE			118795
18	204086860	1	FORCELLA	FOURCHE	GABEL	YOKE			118795
19	403000032R10	1	PULSANTE	BOUTON	DRUCKKNOPF	PUSH BOTTON			118795
20	5070M0355	1	FORCELLA	FOURCHE	GABEL	YOKE			118795
21	341054000R10	1	SPINA	GOUPILLE	STIFT	PIN			118795
22	399143000	1	ETICHETTA	ETIQUETE	ETIKETT	LABEL			118795
23	255080006R02	1	GHIERA	FRETTE	NUTMUTTER	RING NUT			118795
24	517080120	1	CUFFIA	CAPOUCHON	HAUBE	GUARD			118795
25	236840402	1	TUBO INTERNO	TUBE INTERIEUR	INNENROHR	INTERNAL TUBE			118795

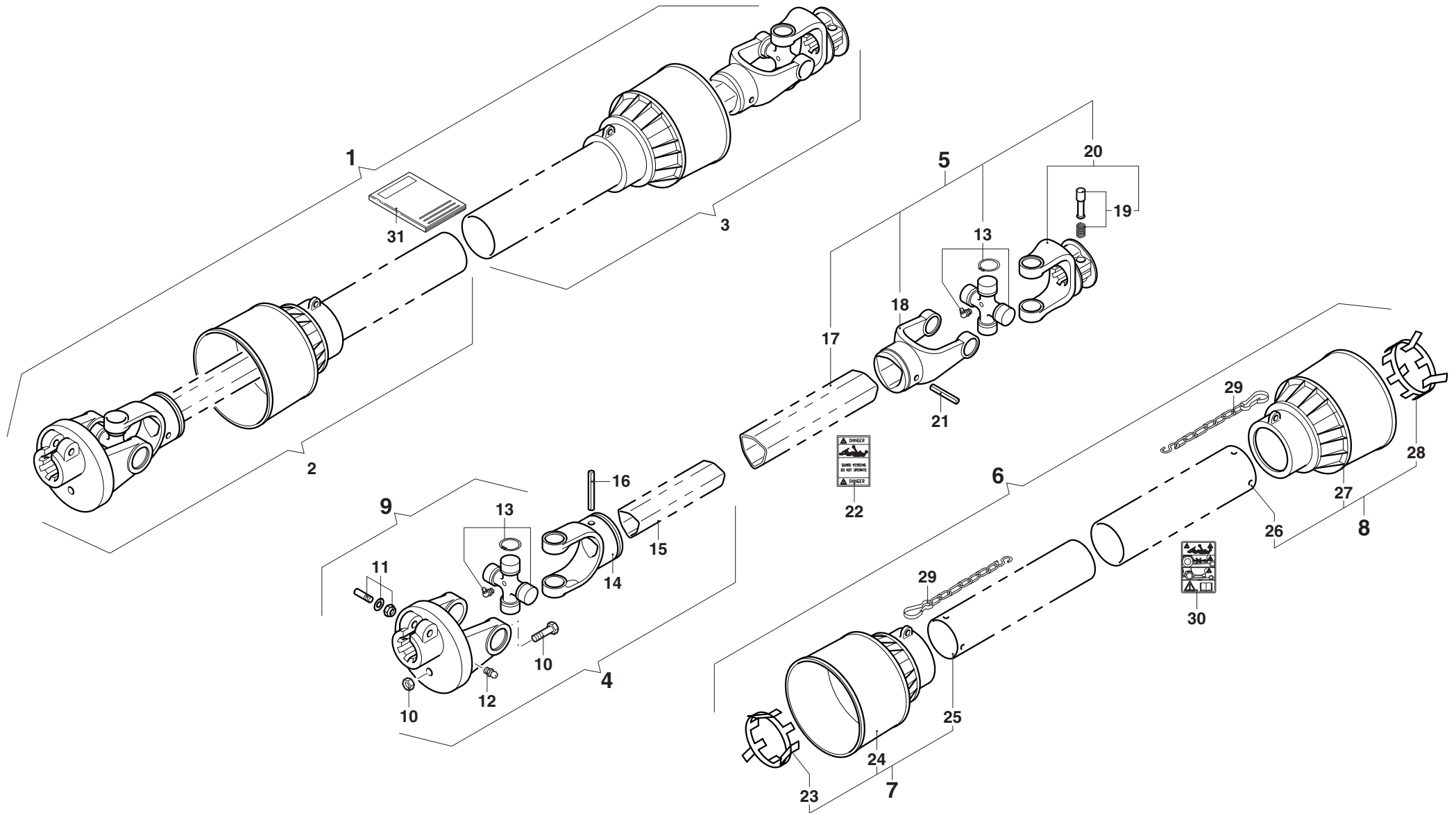

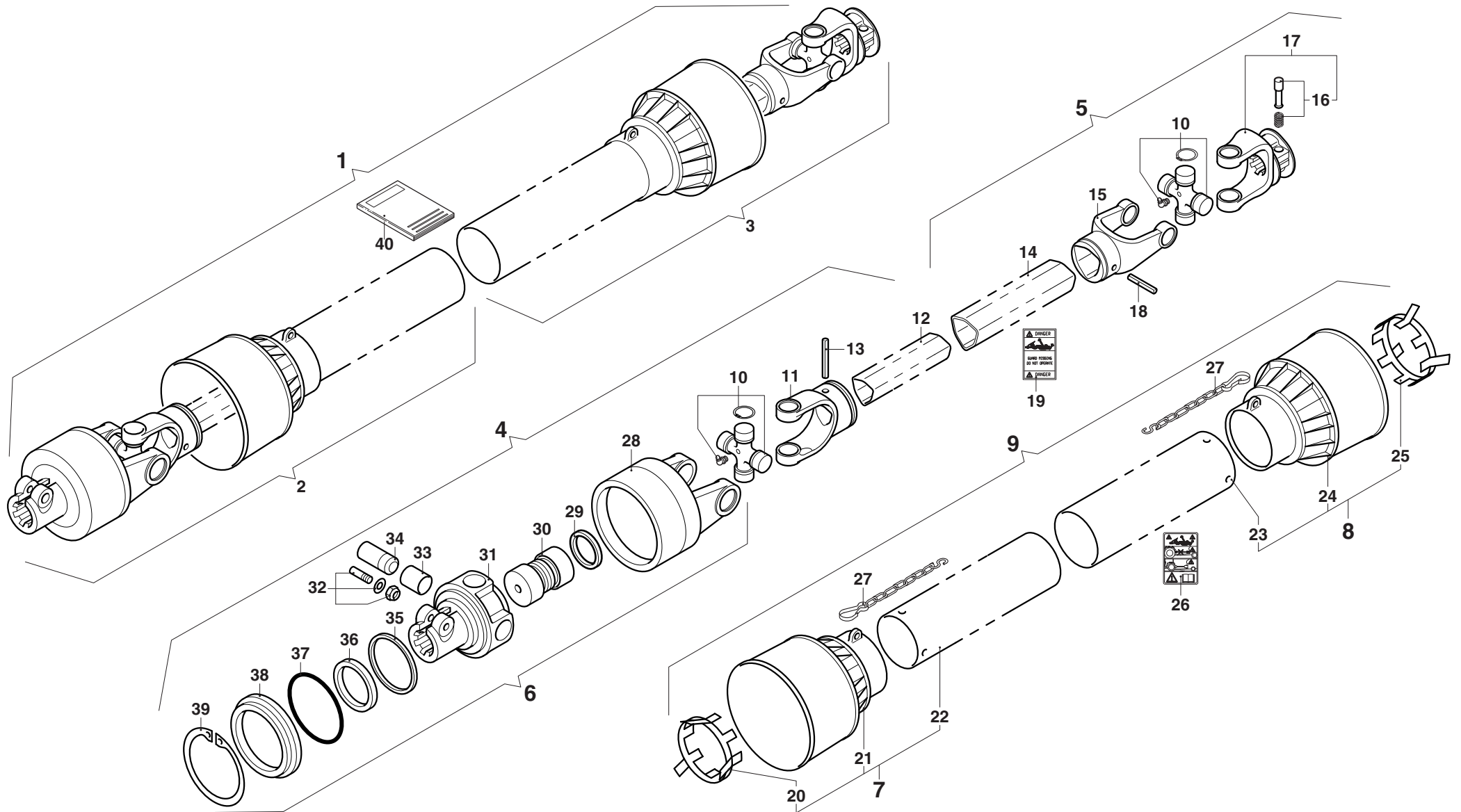

MURATORI ME 22 C (250)

TAV. 15.0

POS.	N° CODICE	Q.	DESCRIZIONE	DESIGNATION	BENENNUNG	DESCRIPTION	DESIGNAZIONE	Da matr. De nr. serie Vom Seriennr. From serial nr.	Fino matr. Jusqu'au nr. serie Bis Seriennr. Up to serial nr.
1	A809FLRG	1	ALBERO CARDANICO COMPLETO	ARBRE A JOINTS DE CARDAN	KARDANWELLE	PTO SHAFT			118795
2	7118066CE37A	1	SEMIALBERO INTERNO	DEMI-ARBRE INTERIEUR	INNENHALBWELLE	INTERNAL HALF SHAFT			118795
3	7E18066CE007	1	SEMIALBERO ESTERNO	DEMI-ARBRE EXTERIEUR	AUSSENHALBWELLE	EXTERNAL HALF SHAFT			118795
4	71180660037A	1	SEMIALBERO INTERNO	DEMI-ARBRE INTERIEUR	INNENHALBWELLE	INTERNAL HALF SHAFT			118795
5	7E1806600007	1	SEMIALBERO ESTERNO	DEMI-ARBRE EXTERIEUR	AUSSENHALBWELLE	EXTERNAL HALF SHAFT			118795
6	6WM270004R	1	FRIZIONE	EMBRAYAGE	KUPPLUNG	CLUTCH			118795
7	5F18066FFCE	1	PROTEZIONE	PROTECTION	SCHUTZ	GUARD			118795
8	5FE8066FFCE	1	PROTEZIONE INTERNA	PROTECTION INTERIEURE	INNENSCHUTZ	INTERNAL GUARD			118795
9	5F08066FFCE	1	PROTEZIONE ESTERNA	PROTECTION EXTERIEURE	AUSSENSCHUTZ	EXTERNAL GUARD			118795
10	4120M0011R20	2	CROCIERA	CROISILLON	KREUZSTUECK	SPIDER			118795
11	204086861	1	FORCELLA	FOURCHE	GABEL	YOKE			118795
12	225690475	1	TUBO INTERNO	TUBE INTERIEUR	INNENROHR	INTERNAL TUBE			118795
13	341054000R10	1	SPINA	GOUPILLE	STIFT	PIN			118795
14	225730475	1	TUBO ESTERNO	TUBE EXTERIEUR	AUSSENROHR	EXTERNAL TUBE			118795
15	204086860	1	FORCELLA	FOURCHE	GABEL	YOKE			118795
16	403000032R10	1	PULSANTE	BOUTON	DRUCKKNOPF	PUSH BOTTON			118795
17	5070M0355	1	FORCELLA	FOURCHE	GABEL	YOKE			118795
18	341054000R10	1	SPINA	GOUPILLE	STIFT	PIN			118795
19	399143000	1	ETICHETTA	ETIQUETE	ETIKETT	LABEL			118795
20	255080006R02	1	GHIERA	FRETTE	NUTMUTTER	RING NUT			118795
21	517080120	1	CUFFIA	CAPOUCHON	HAUBE	GUARD			118795
22	236840402	1	TUBO INTERNO	TUBE INTERIEUR	INNENROHR	INTERNAL TUBE			118795
23	236850402	1	TUBO ESTERNO	TUBE EXTERIEUR	AUSSENROHR	EXTERNAL TUBE			118795
24	517080130	1	CUFFIA	CAPOUCHON	HAUBE	GUARD			118795
25	255080005R02	1	GHIERA	FRETTE	NUTMUTTER	RING NUT			118795

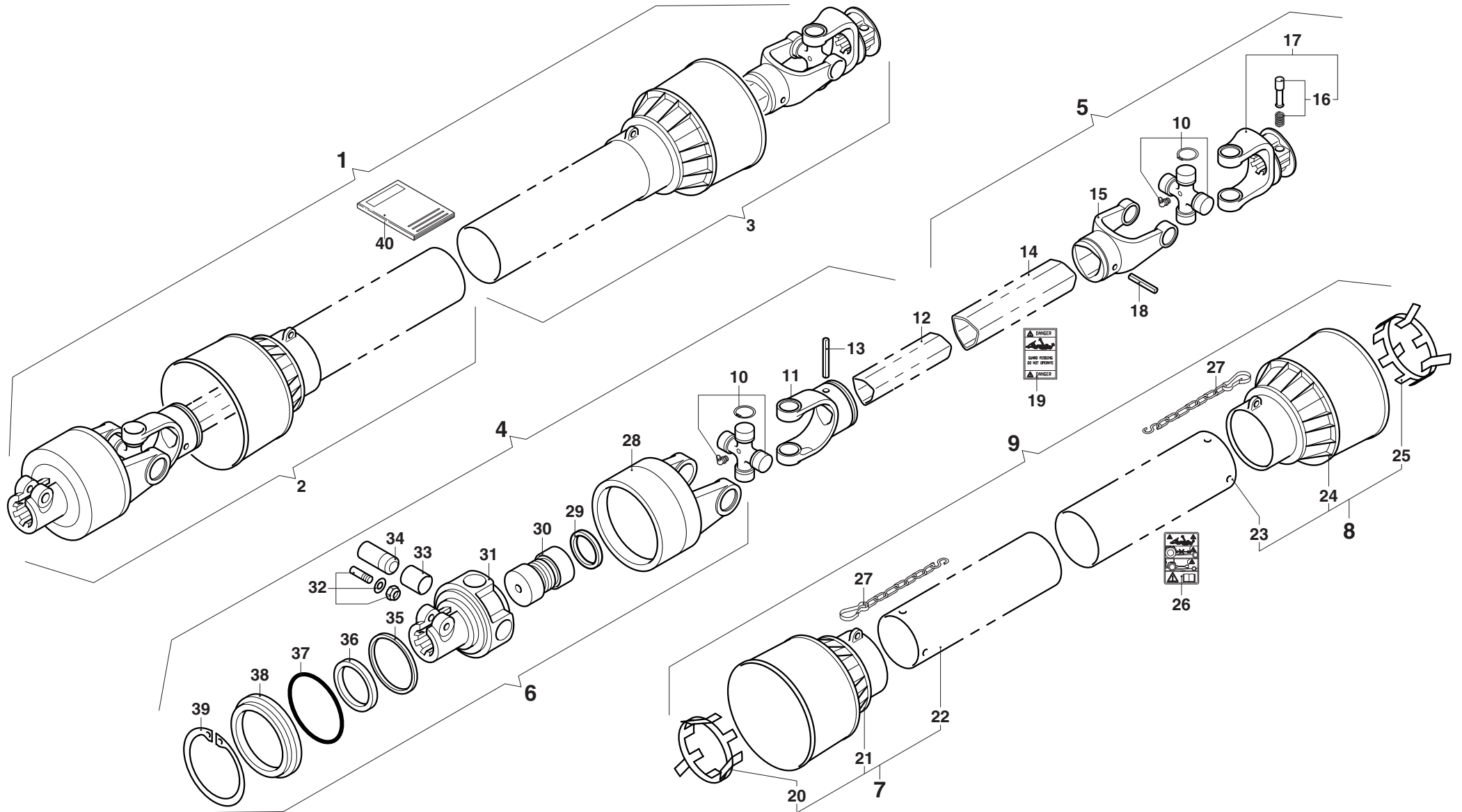

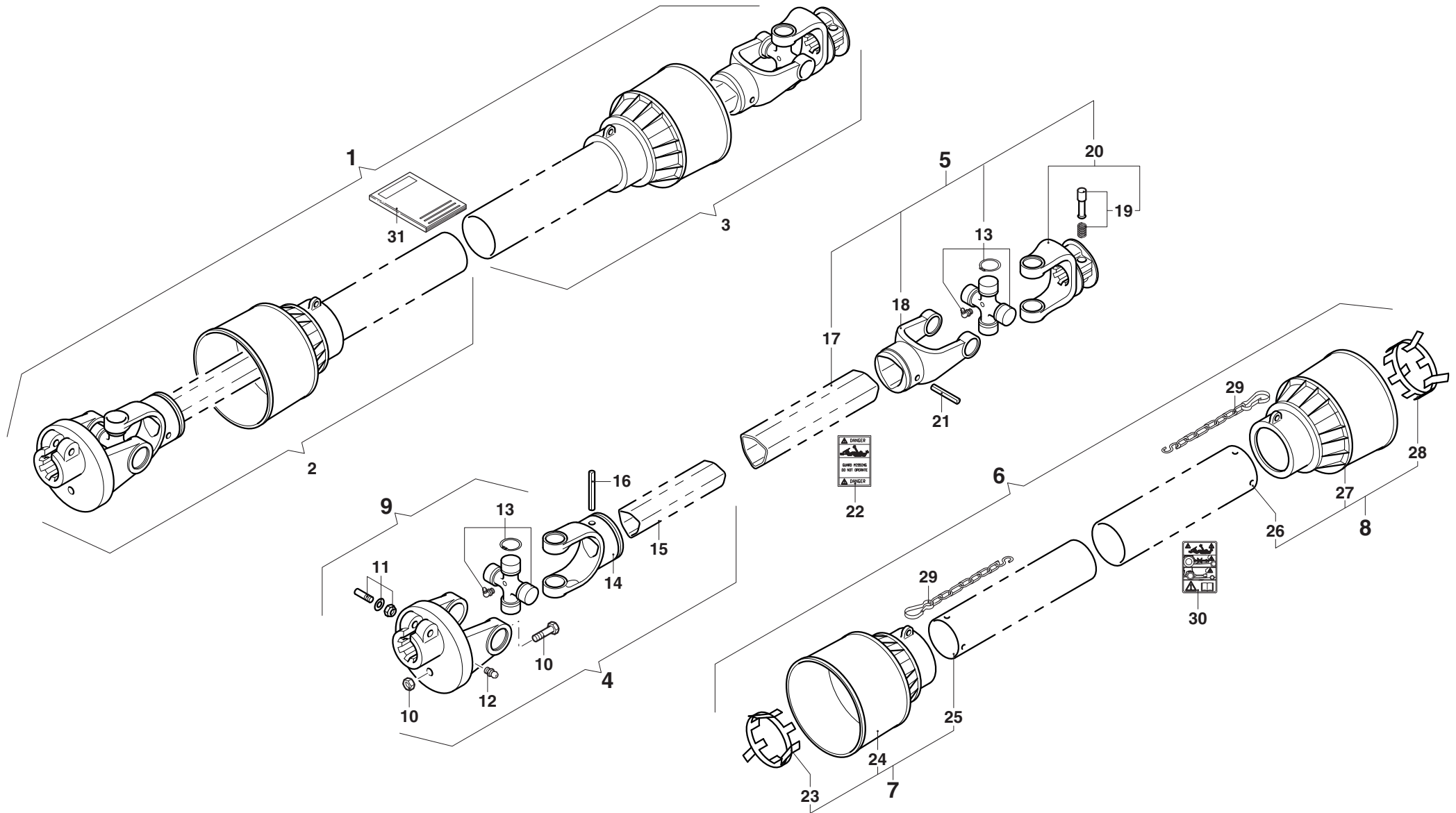

MURATORI ME 22 C (200-250)

TAV. 16.0

POS.	N° CODICE	Q.	DESCRIZIONE	DESIGNATION	BENENNUNG	DESCRIPTION	DESIGNAZIONE	Da matr.	Fino matr.
								De nr. serie Vom Seriennr. From serial nr.	Jusqu'au nr. serie Bis Seriennr. Up to serial nr.
1	A809FSBG	1	ALBERO CARDANICO COMPLETO	ARBRE A JOINTS DE CARDAN	KARDANWELLE	PTO SHAFT			
							118796	125255	
2	7118066CE1R5	1	SEMIALBERO INTERNO	DEMI-ARBRE INTERIEUR	INNENHALBWELLE	INTERNAL HALF SHAFT			
							118796	125255	
3	7E18066CE007	1	SEMIALBERO ESTERNO	DEMI-ARBRE EXTERIEUR	AUSSENHALBWELLE	EXTERNAL HALF SHAFT			
							118796	125255	
4	7118066001R5	1	SEMIALBERO INTERNO	DEMI-ARBRE INTERIEUR	INNENHALBWELLE	INTERNAL HALF SHAFT			
							118796	125255	
5	7E1806600007	1	SEMIALBERO ESTERNO	DEMI-ARBRE EXTERIEUR	AUSSENHALBWELLE	EXTERNAL HALF SHAFT			
							118796	125255	
6	5F08066FFCE	1	PROTEZIONE	PROTECTION	SCHUTZ	GUARD			
							118796	125255	
7	5F18066FFCE	1	PROTEZIONE INTERNA	PROTECTION INTERIEURE	INNENSCHUTZ	INTERNAL GUARD			
							118796	125255	
8	5FE8066FFCE	1	PROTEZIONE ESTERNA	PROTECTION EXTERIEURE	AUSSENSCHUTZ	EXTERNAL GUARD			
							118796	125255	
9	6060M0407R	1	FORCELLA	FOURCHE	GABEL	YOKE			
							118796	125255	
10	432000053R05	1	BULLONE	BOULON	BOLZEN	BOLT			
							118796	125255	
11	408000052R02	1	PERNO	PIVOT	BOLZEN	PIN			
							118796	125255	
12	348017000R20	1	INGRASSATORE	GRAISSEUR	SCHMIERNIPPEL	GREASE FITTING			
							118796	125255	
13	4120M0011R20	2	CROCIERA	CROISILLON	KREUZSTUECK	SPIDER			
							118796	125255	
14	204086861	1	FORCELLA	FOURCHE	GABEL	YOKE			
							118796	125255	
15	225690475	1	TUBO INTERNO	TUBE INTERIEUR	INNENROHR	INTERNAL TUBE			
							118796	125255	
16	341055000R10	1	SPINA	GOUPILLE	STIFT	PIN			
							118796	125255	
17	225730475	1	TUBO ESTERNO	TUBE EXTERIEUR	AUSSENROHR	EXTERNAL TUBE			
							118796	125255	
18	204086860	1	FORCELLA	FOURCHE	GABEL	YOKE			
							118796	125255	
19	403000032R10	1	PULSANTE	BOUTON	DRUCKKNOPF	PUSH BOTTON			
							118796	125255	
20	5070M0355	1	FORCELLA	FOURCHE	GABEL	YOKE			
							118796	125255	
21	341054000R10	1	SPINA	GOUPILLE	STIFT	PIN			
							118796	125255	
22	399143000	1	ETICHETTA	ETIQUETE	ETIKETT	LABEL			
							118796	125255	
23	255080006R02	1	GHIERA	FRETTE	NUTMUTTER	RING NUT			
							118796	125255	
24	517080120	1	CUFFIA	CAPOUCHON	HAUBE	GUARD			
							118796	125255	
25	236840402	1	TUBO INTERNO	TUBE INTERIEUR	INNENROHR	INTERNAL TUBE			
							118796	125255	

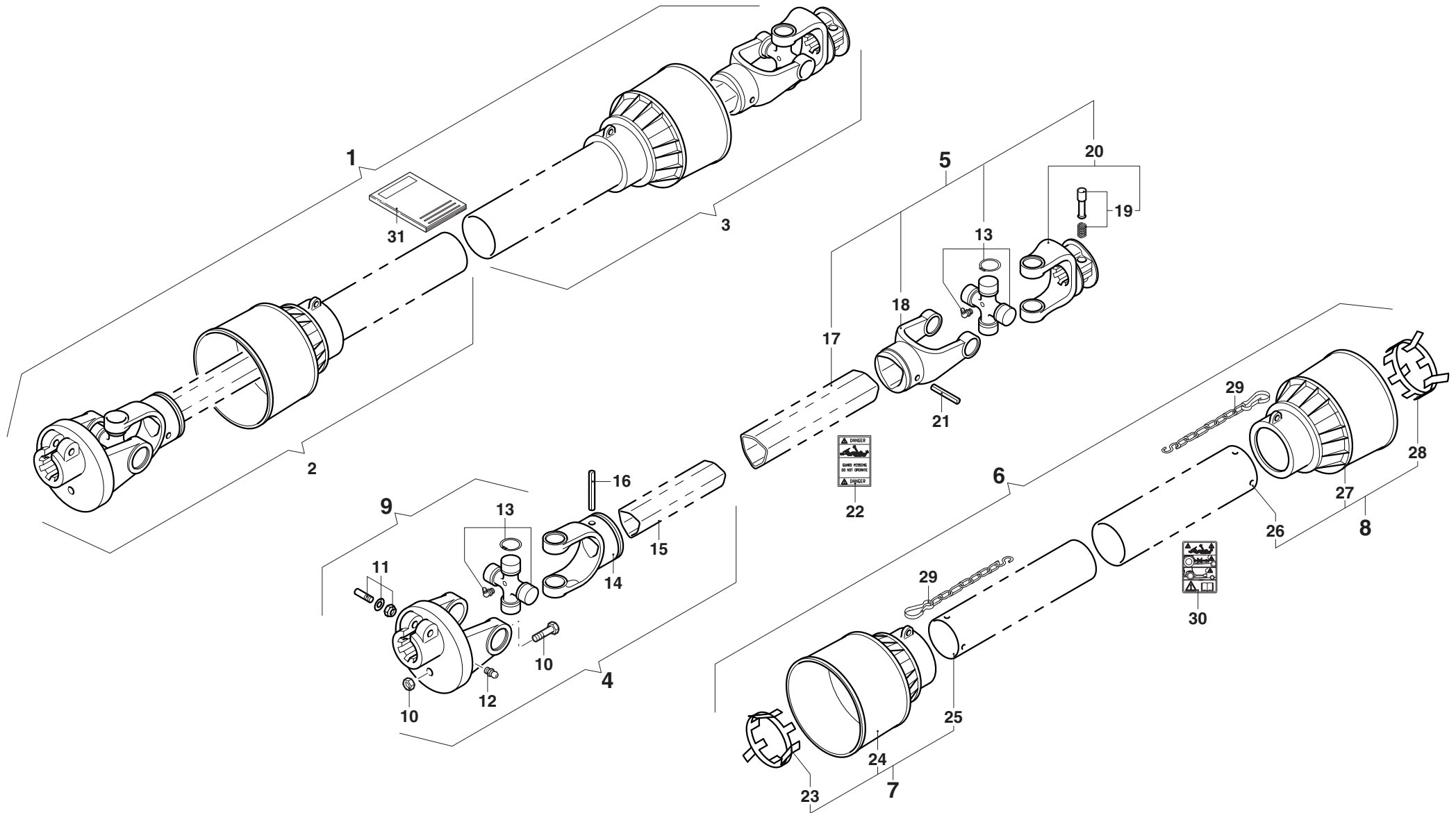

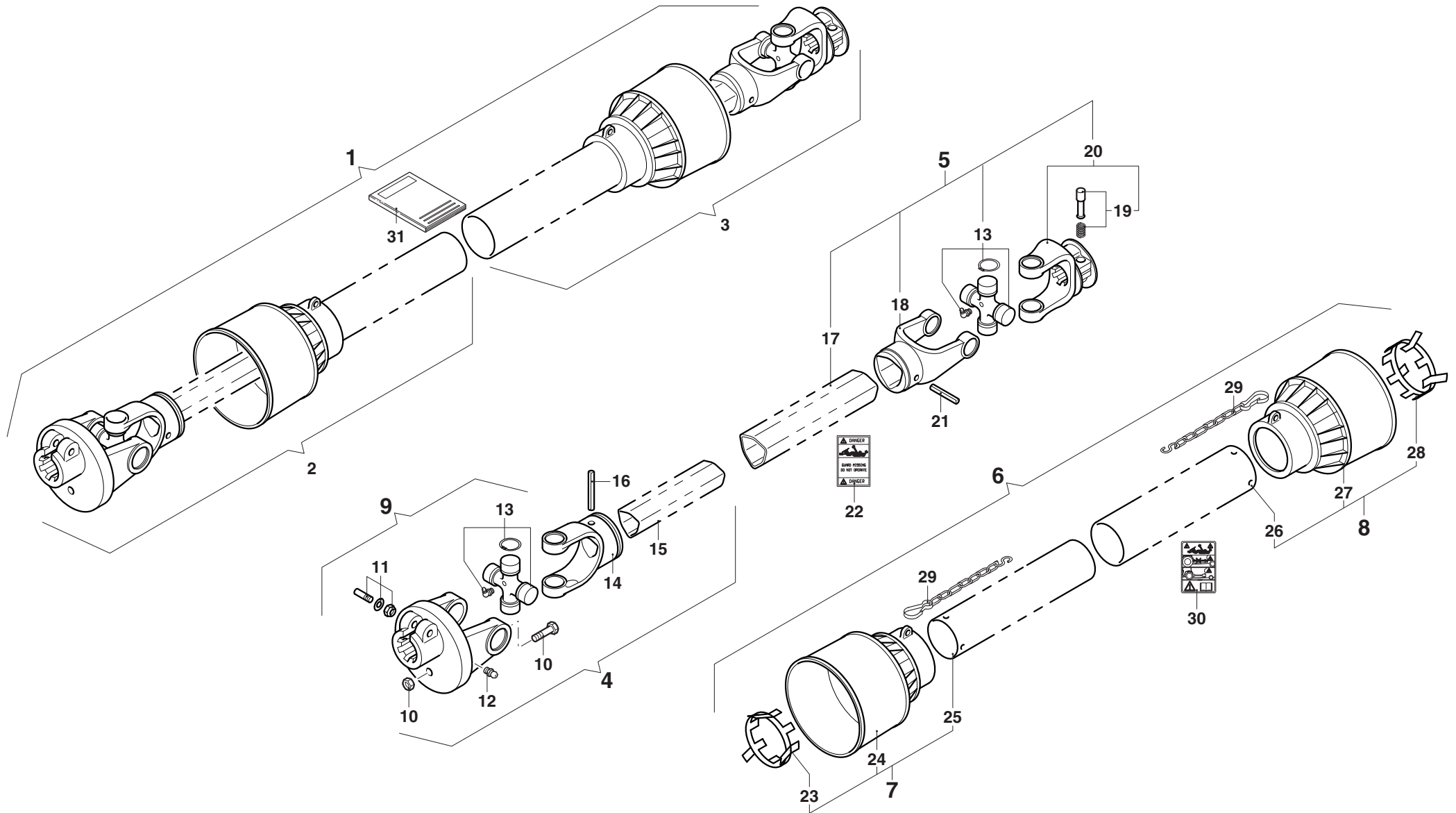

MURATORI ME 22 - ME 22 C

TAV. 16.1

POS.	N° CODICE	Q.	DESCRIZIONE	DESIGNATION	BENENNUNG	DESCRIPTION	DESIGNAZIONE	Da matr.	Fino matr.
								De nr. serie Vom Seriennr. From serial nr.	Jusqu'au nr. serie Bis Seriennr. Up to serial nr.
1	AB809FSBG	1	ALBERO CARDANICO COMPLETO	ARBRE A JOINTS DE CARDAN	KARDANWELLE	PTO SHAFT		125256	
2	7118066CE1R5	1	SEMIALBERO INTERNO	DEMI-ARBRE INTERIEUR	INNENHALBWELLE	INTERNAL HALF SHAFT		125256	
3	7E18066CE007	1	SEMIALBERO ESTERNO	DEMI-ARBRE EXTERIEUR	AUSSENHALBWELLE	EXTERNAL HALF SHAFT		125256	
4	7118066001R5	1	SEMIALBERO INTERNO	DEMI-ARBRE INTERIEUR	INNENHALBWELLE	INTERNAL HALF SHAFT		125256	
5	7E1806600007	1	SEMIALBERO ESTERNO	DEMI-ARBRE EXTERIEUR	AUSSENHALBWELLE	EXTERNAL HALF SHAFT		125256	
6	5F08066FFCE	1	PROTEZIONE	PROTECTION	SCHUTZ	GUARD		125256	
7	5F18066FFCE	1	PROTEZIONE INTERNA	PROTECTION INTERIEURE	INNENSCHUTZ	INTERNAL GUARD		125256	
8	5FE8066FFCE	1	PROTEZIONE ESTERNA	PROTECTION EXTERIEURE	AUSSENSCHUTZ	EXTERNAL GUARD		125256	
9	6060M0407R	1	FORCELLA	FOURCHE	GABEL	YOKE		125256	
10	432000053R05	1	BULLONE	BOULON	BOLZEN	BOLT		125256	
11	408000052R02	1	PERNO	PIVOT	BOLZEN	PIN		125256	
12	348017000R20	1	INGRASSATORE	GRAISSEUR	SCHMIERNIPPEL	GREASE FITTING		125256	
13	4120M0011R20	2	CROCIERA	CROISILLON	KREUZSTUECK	SPIDER		125256	
14	204086861	1	FORCELLA	FOURCHE	GABEL	YOKE		125256	
15	225690475	1	TUBO INTERNO	TUBE INTERIEUR	INNENROHR	INTERNAL TUBE		125256	
16	341055000R10	1	SPINA	GOUPILLE	STIFT	PIN		125256	
17	225730475	1	TUBO ESTERNO	TUBE EXTERIEUR	AUSSENROHR	EXTERNAL TUBE		125256	
18	204086860	1	FORCELLA	FOURCHE	GABEL	YOKE		125256	
19	403000032R10	1	PULSANTE	BOUTON	DRUCKKNOPF	PUSH BOTTON		125256	
20	5070M0355	1	FORCELLA	FOURCHE	GABEL	YOKE		125256	
21	341054000R10	1	SPINA	GOUPILLE	STIFT	PIN		125256	
22	399143000	1	ETICHETTA	ETIQUETE	ETIKETT	LABEL		125256	
23	255080006R02	1	GHIERA	FRETTE	NUTMUTTER	RING NUT		125256	
24	517080120	1	CUFFIA	CAPOUCHON	HAUBE	GUARD		125256	
25	236840402	1	TUBO INTERNO	TUBE INTERIEUR	INNENROHR	INTERNAL TUBE		125256	

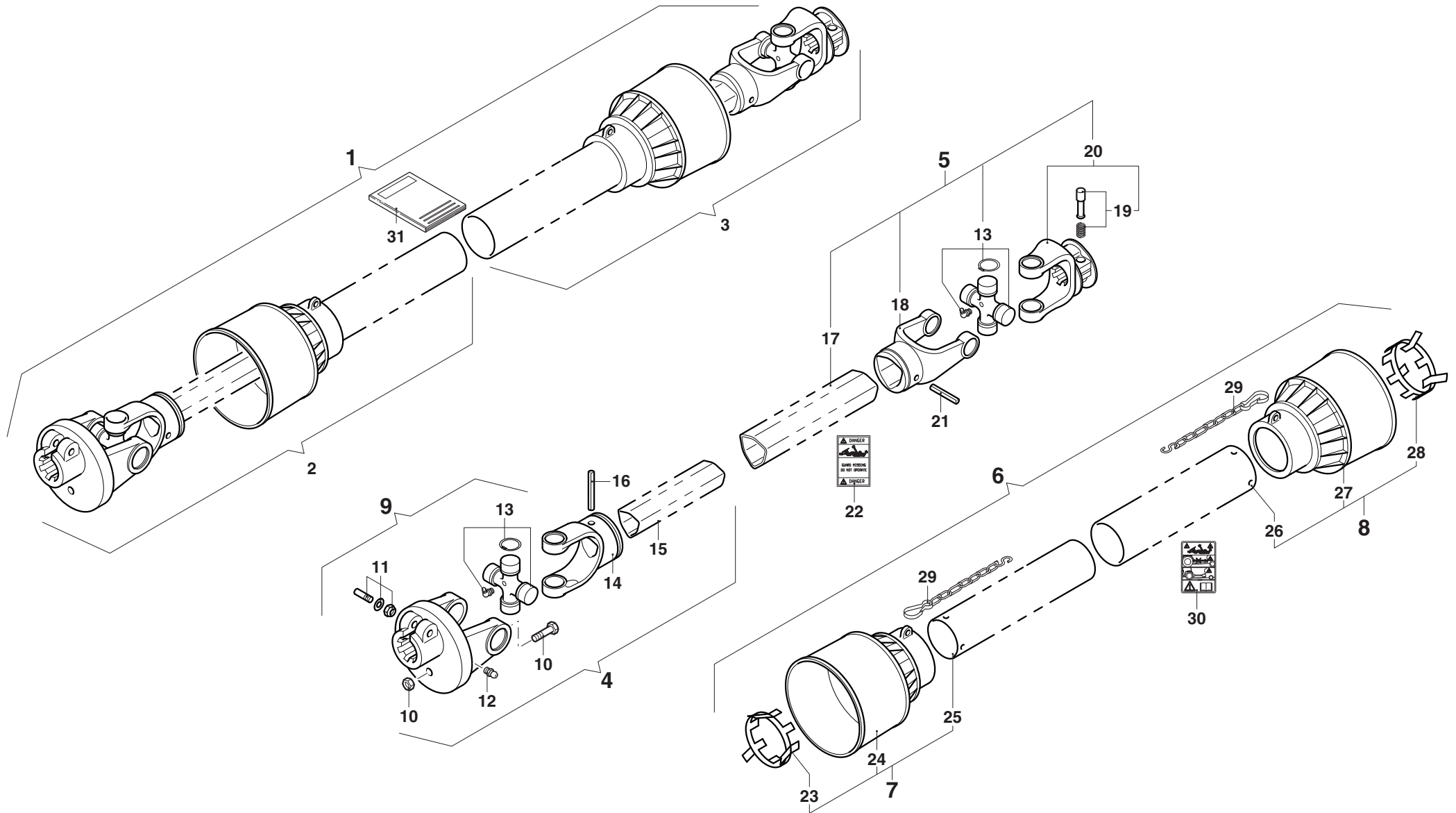

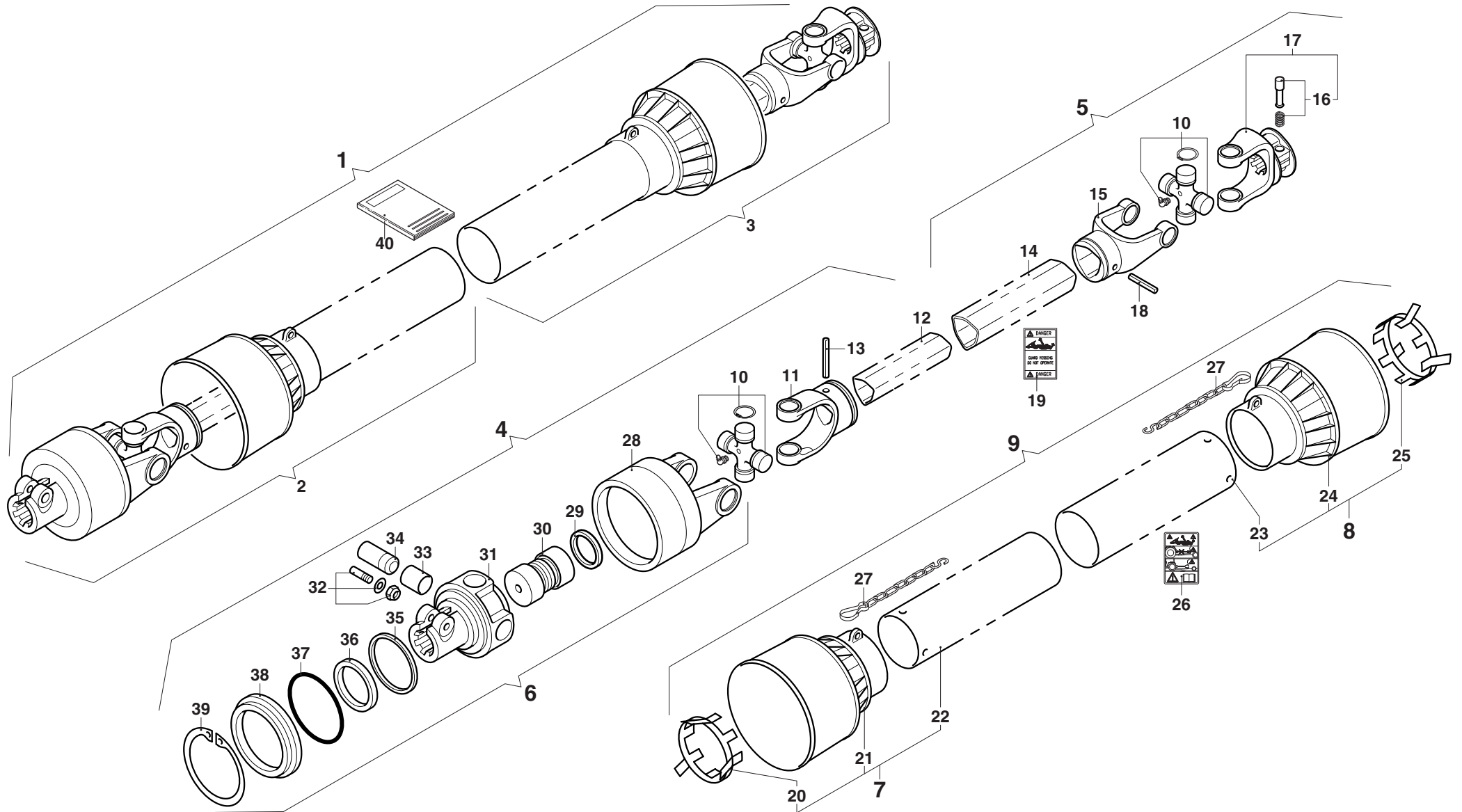

MURATORI ME 22 C (200-250)

TAV. 17.0

POS.	N° CODICE	Q.	DESCRIZIONE	DESIGNATION	BENENNUNG	DESCRIPTION	DESIGNAZIONE	Da matr. De nr. serie Vom Seriennr. From serial nr.	Fino matr. Jusqu'au nr. serie Bis Seriennr. Up to serial nr.
1	A809FLRG	1	ALBERO CARDANICO COMPLETO	ARBRE A JOINTS DE CARDAN	KARDANWELLE	PTO SHAFT		118796	
2	7118066CE37A	1	SEMIALBERO INTERNO	DEMI-ARBRE INTERIEUR	INNENHALBWELLE	INTERNAL HALF SHAFT		118796	
3	7E18066CE007	1	SEMIALBERO ESTERNO	DEMI-ARBRE EXTERIEUR	AUSSENHALBWELLE	EXTERNAL HALF SHAFT		118796	
4	71180660037A	1	SEMIALBERO INTERNO	DEMI-ARBRE INTERIEUR	INNENHALBWELLE	INTERNAL HALF SHAFT		118796	
5	7E1806600007	1	SEMIALBERO ESTERNO	DEMI-ARBRE EXTERIEUR	AUSSENHALBWELLE	EXTERNAL HALF SHAFT		118796	
6	6WM270004R	1	FRIZIONE	EMBRAYAGE	KUPPLUNG	CLUTCH		118796	
7	5F18066FFCE	1	PROTEZIONE	PROTECTION	SCHUTZ	GUARD		118796	
8	5FE8066FFCE	1	PROTEZIONE INTERNA	PROTECTION INTERIEURE	INNENSCHUTZ	INTERNAL GUARD		118796	
9	5F08066FFCE	1	PROTEZIONE ESTERNA	PROTECTION EXTERIEURE	AUSSENSCHUTZ	EXTERNAL GUARD		118796	
10	4120M0011R20	2	CROCIERA	CROISILLON	KREUZSTUECK	SPIDER		118796	
11	204086861	1	FORCELLA	FOURCHE	GABEL	YOKE		118796	
12	225690475	1	TUBO INTERNO	TUBE INTERIEUR	INNENROHR	INTERNAL TUBE		118796	
13	341054000R10	1	SPINA	GOUPILLE	STIFT	PIN		118796	
14	225730475	1	TUBO ESTERNO	TUBE EXTERIEUR	AUSSENROHR	EXTERNAL TUBE		118796	
15	204086860	1	FORCELLA	FOURCHE	GABEL	YOKE		118796	
16	403000032R10	1	PULSANTE	BOUTON	DRUCKKNOPF	PUSH BOTTON		118796	
17	5070M0355	1	FORCELLA	FOURCHE	GABEL	YOKE		118796	
18	341054000R10	1	SPINA	GOUPILLE	STIFT	PIN		118796	
19	399143000	1	ETICHETTA	ETIQUETE	ETIKETT	LABEL		118796	
20	255080006R02	1	GHIERA	FRETTE	NUTMUTTER	RING NUT		118796	
21	517080120	1	CUFFIA	CAPOUCHON	HAUBE	GUARD		118796	
22	236840402	1	TUBO INTERNO	TUBE INTERIEUR	INNENROHR	INTERNAL TUBE		118796	
23	236850402	1	TUBO ESTERNO	TUBE EXTERIEUR	AUSSENROHR	EXTERNAL TUBE		118796	
24	517080130	1	CUFFIA	CAPOUCHON	HAUBE	GUARD		118796	
25	255080005R02	1	GHIERA	FRETTE	NUTMUTTER	RING NUT		118796	

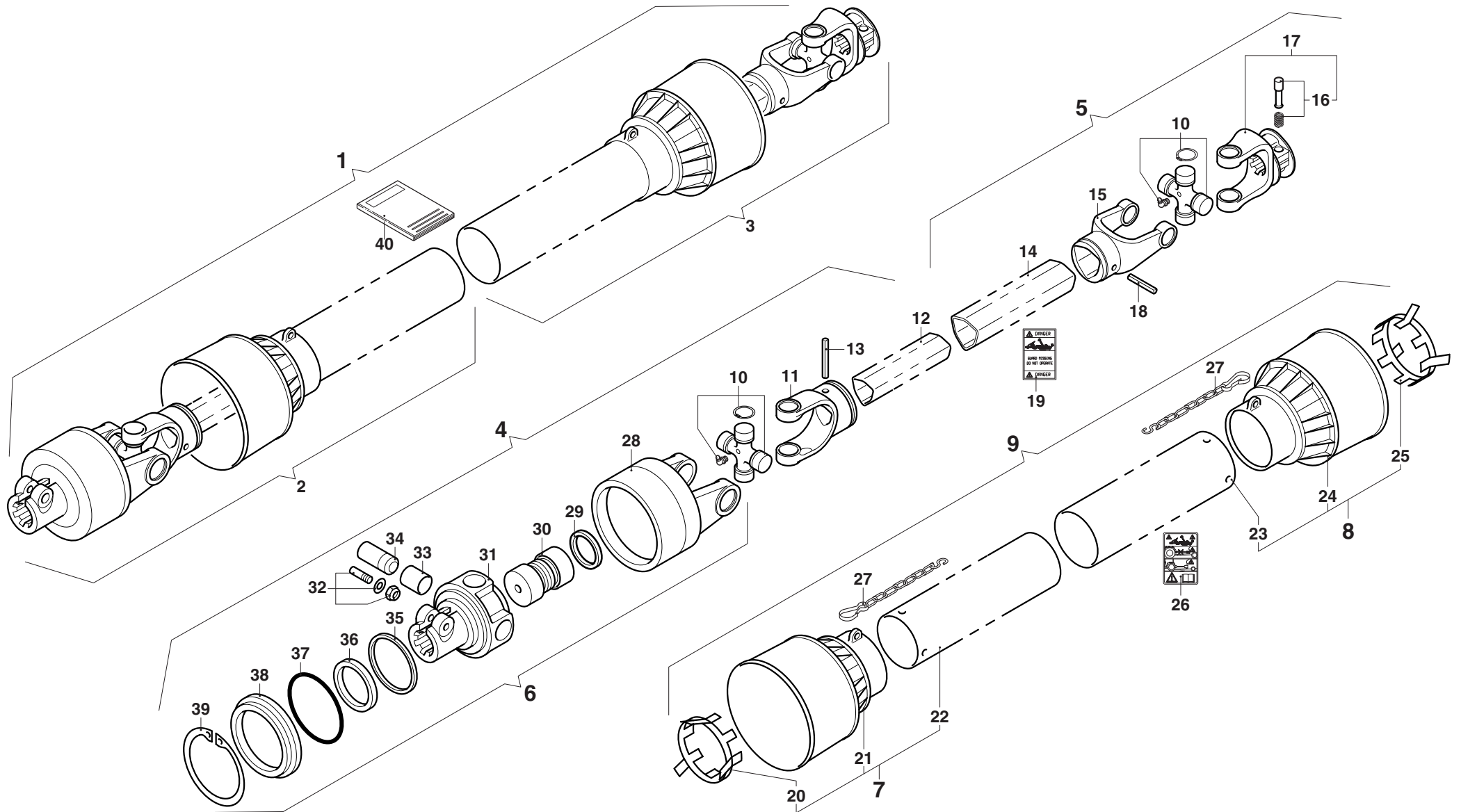



MURATORI S.p.A.

Via Pavarello, 21 - 41051 Castelnuovo Rangone (MO) Italy - Tel. 059.5330611 Fax 059.537259

www.muratoriequip.it *info@muratoriequip.it*

Capitale sociale Euro 480.000 interamente versato

Registro Imprese di Modena

Codice fiscale e numero d'iscrizione: 00708860366