



MURATORI

**TIPO-TYPE-TYP
MR**

CATALOGO RICAMBI
Catalogue Pièces Detachées
Ersatzteilkatalog
Spare Parts Catalogue
Catálogo Recambios

EDIZIONE 02/2024

Per ordinare parti di ricambio specificare:

- tipo e matricola della macchina (apposti sulla macchina o sui documenti di acquisto);
- numero del riferimento del pezzo nel disegno (Pos.), numero della tavola (Tav.) e numero di codice

N.B.: le indicazioni destro o sinistro vengono date guardando la macchina da dietro.

Pour les commandes de pièces de rechange veuillez spécifier:

- *type et numéro de série de la machine (indiqués sur la machine et sur le bon d'achat);*
- *numéro de référence du pièce sur le plan (Pos.), numéro du plan (Tav.) et numéro de code (codice)*

N.B.: *les indications droite ou gauche sont données en regardant la machine par derrière.*

Zum Bestellen von Ersatzteilen folgendes angeben:

- *Typ und Serien-Nr. der Maschine (zu finden auf der Maschine oder der Einkaufspapieren);*
- *Bezug-Nr. des Ersatzteils auf der Zeichnung (Pos.), Zeichnungsnummer (Tav.) und Kodenummer (codice)*

N.B.: *die Angaben rechts und links verstehen sich so, dass man hinter der Maschine steht.*

When ordering spare parts specify:

- machine type and serial number (found on the machine or on the purchasing documents);
- reference number of the part on the relative drawing (Pos.) number of the drawing (Tav.) and part number (codice)

N.B.: right-hand or left-hand indications are made by viewing the machine from the rear.

TAV. 1.0

GRUPPO TELAIO
ENSEMBLE CHASSIS
SATZ FÜR RAHMEN
KIT FOR FRAME

TAV. 2.0

TRASMISSIONE ROTORI
TRANSMISSION ROTORS
ROTOREN ANTRIEB
ROTORS TRANSMISSION

TAV. 2.1 Fino matr. - *Jusqu'au nr. serie* - Bis Seriennr. - *Up to serial nr.* **85719**

TRASMISSIONE ROTORI - 2000 RPM
TRANSMISSION ROTORS - 2000 RPM
ROTOREN ANTRIEB - 2000 RPM
ROTORS TRANSMISSION - 2000 RPM

TAV. 2.2 Da matr. - *De nr. serie* - Vom Seriennr. - *From serial nr.* **85720**

TRASMISSIONE ROTORI - 2000 RPM
TRANSMISSION ROTORS - 2000 RPM
ROTOREN ANTRIEB - 2000 RPM
ROTORS TRANSMISSION - 2000 RPM

TAV. 3.0

CONVOGLIAMENTO LATERALE
SIDE DISCHARGE
SEITLICH AUSWURF
EJECTION LATERAL

TAV. 4.0

CONVOGLIAMENTO POSTERIORE
EJECTION ARRIERE
HECK AUSWURF
REAR DISCHARGE

TAV. 5.0

GRUPPO MOLTIPLICATORE - 540 RPM
ENSEMBLE MULTIPLICATEUR - 540 RPM
SATZ FÜR GETRIEBE - 540 UPM
KIT FOR GEAR BOX - 540 RPM

TAV. 5.2 Fino matr. - *Jusqu'au nr. serie* - Bis Seriennr. - *Up to serial nr.* **83556**

GRUPPO MOLTIPLICATORE (COMER) 1000 RPM
ENSEMBLE MULTIPL. (COMER) 1000 RPM
SATZ FÜR GETRIEBE (COMER) 1000 UPM
KIT FOR GEAR BOX (COMER) 1000 RPM

TAV. 5.3 Da matr. - *De nr. serie* - Vom Seriennr. - *From serial nr.* **83557**

GRUPPO MOLTIPLICATORE - 1000 RPM
ENSEMBLE MULTIPLICATEUR - 1000 RPM
SATZ FÜR GETRIEBE - 1000 UPM
KIT FOR GEAR BOX - 1000 RPM

TAV. 5.4 Fino matr. - *Jusqu'au nr. serie* - Bis Seriennr. - *Up to serial nr.* **85719**

GRUPPO MOLTIPLICATORE - 2000 RPM
ENSEMBLE MULTIPLICATEUR - 2000 RPM
SATZ FÜR GETRIEBE - 2000 UPM
KIT FOR GEAR BOX - 2000 RPM

TAV. 5.5 Da matr. - *De nr. serie* - Vom Seriennr. - *From serial nr.* **85720**

GRUPPO MOLTIPLICATORE - 2000 RPM
ENSEMBLE MULTIPLICATEUR - 2000 RPM
SATZ FÜR GETRIEBE - 2000 UPM
KIT FOR GEAR BOX - 2000 RPM

TAV. 6.0

VERSIONE "MULCHING"
VERSION "MULCHING"
"MULCHING" VERSION
"MULCHING" VERSION

TAV. 7.0

ATTACCO FRONTALE STANDARD
ATTELAGE FRONTAL
FRONTANBAU
FRONT LINKAGE

TAV. 8.0

ATTACCO FRONTALE RAPIDO
ATTELAGE FRONTAL RAPIDE
FRONTKUPPELDREIECK
QUICK FRONT LINKAGE

TAV. 9.0

INGRASSATORI ESTERNI
GRAISSAGE CENTRALISE
SAMMELSCHMIERUNG
GREASE EXTENSIONS

TAV. 10.0

RUOTINO ANTISCALPO
ROULEAU ANTICHOC
GEGENSTOSSIGE ROLLE
ANTISCALPING ROLL

TAV. 11.0 Fino matr. - *Jusqu'au nr. serie* - Bis Seriennr. - *Up to serial nr.* **124405**

RUOTE PNEUMATICHE
ROUES PNEUMATIQUES
PNEURÄDER
TYRE WHEELS

TAV. 11.1

RUOTE PNEUMATICHE
ROUES PNEUMATIQUES
PNEURÄDER
TYRE WHEELS

TAV. 12.0 MR 120-135

ALBERO CARDANICO COMPLETO - AE209SFDO
ARBRE A JOINTS DE CARDAN - AE2109SFDO
KARDANWELLE - AE209SFDO
PTO SHAFT - AE209SFDO

TAV. 13.0 MR 150-180-210

ALBERO CARDANICO COMPLETO - AE210SFDO
ARBRE A JOINTS DE CARDAN - AE210SFDO
KARDANWELLE - AE210SFDO
PTO SHAFT - AE210SFDO

TAV. 14.0

ALBERO CARDANICO COMPLETO - AB210SFDO
ARBRE A JOINTS DE CARDAN - AB210SFDO
KARDANWELLE - AB210SFDO
PTO SHAFT - AB210SFDO

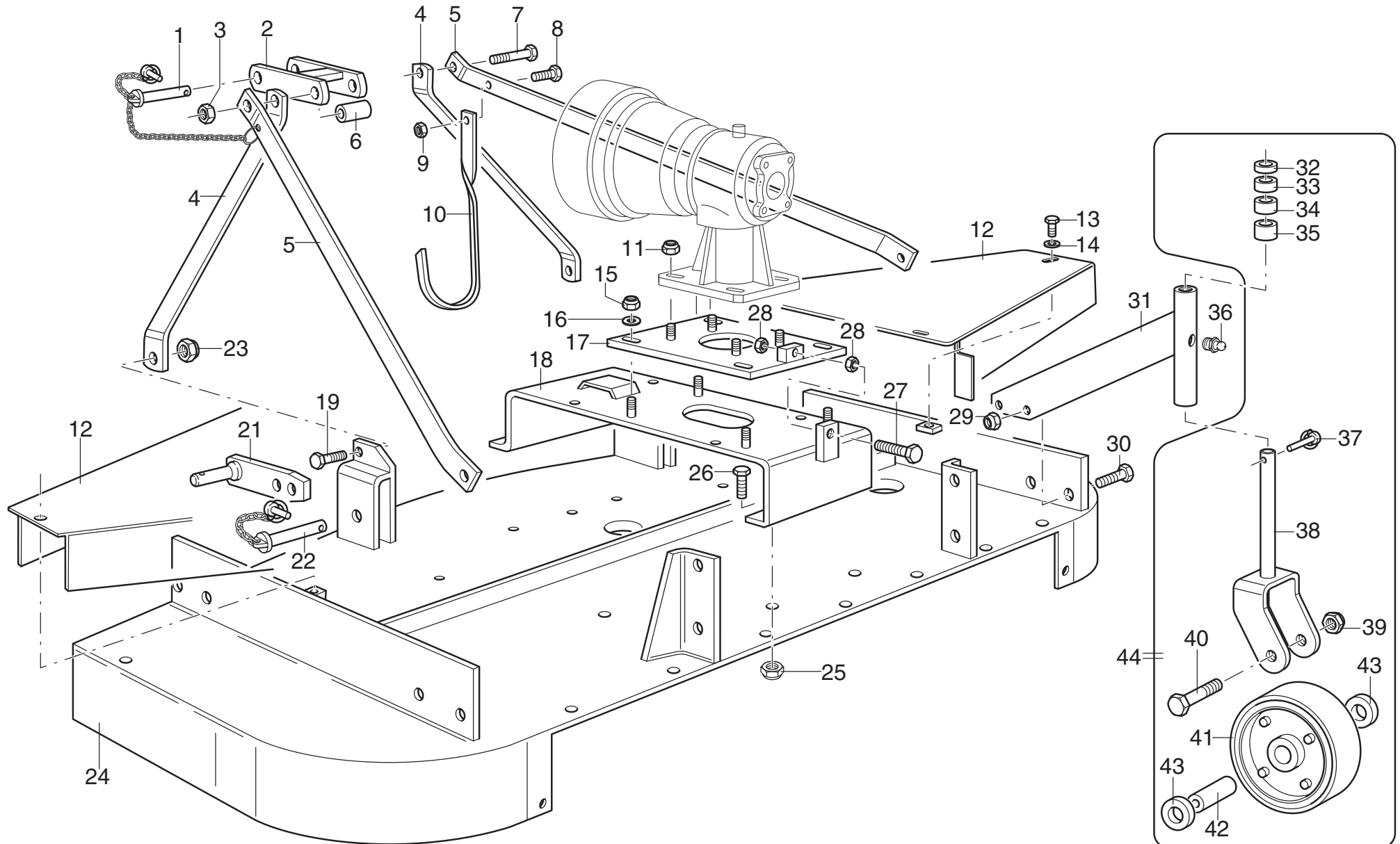

MURATORI MR

TAV. 1.0

POS.	N° CODICE	Q.	DESCRIZIONE	DESIGNATION	BENENNUNG	DESCRIPTION	DESIGNAZIONE	Da matr. De nr. serie Vom Seriennr. From serial nr.	Fino matr. Jusqu'au nr. serie Bis Seriennr. Up to serial nr.
1	38024100	1	PERNO	PIVOT	BOLZEN	PIN			
2	40237800	1	ATTACCO	ATTACHE	ANSCHLUSS	ATTACHMENT			
3	62010600	1	DADO	ECROU	MUTTER	NUT	M 12 x 1,75 AUTOBLOCC.		
4	30178900	2	TIRANTE	TIRANT	STANGE	TIEROD			
5	30182800	2	TIRANTE	TIRANT	STANGE	TIEROD	120		
5	30205300	2	TIRANTE	TIRANT	STANGE	TIEROD	135		
5	30182900	2	TIRANTE	TIRANT	STANGE	TIEROD	150		
5	30183000	2	TIRANTE	TIRANT	STANGE	TIEROD	180		
5	30205400	2	TIRANTE	TIRANT	STANGE	TIEROD	210		
6	32021400	1	DISTANZIALE	ENTRETOISE	DISTANZSTÜCK	SPACER			
7	60011900	1	VITE	VIS	SCHRAUBE	SCREW	TE 12 x 120 UNI 5737		
8	60021300	1	VITE	VIS	SCHRAUBE	SCREW	TE 10 x 30 UNI 5739 8.8 ZNT		
9	62010400	1	DADO	ECROU	MUTTER	NUT	M 10 x 1,5 AUTOBLOCC.		
10	30120100	1	GANCIO	CROCHET	HAKEN	HOOK			
11	62011000	4	DADO	ECROU	MUTTER	NUT	M 16 x 2 AUTOBLOCC.		133355
11	62009000	8	DADO	ECROU	MUTTER	NUT	M 16 x 2 UNI 5933	133356	
12	39259200	2	CARTER	CARTER	SCHUTZABDECKUNG	CASING	120		
12	39305000	2	CARTER	CARTER	SCHUTZABDECKUNG	CASING	135		
12	39259300	2	CARTER	CARTER	SCHUTZABDECKUNG	CASING	150		
12	39259400	2	CARTER	CARTER	SCHUTZABDECKUNG	CASING	180		
12	39305100	2	CARTER	CARTER	SCHUTZABDECKUNG	CASING	210		
13	60024600	6	VITE	VIS	SCHRAUBE	SCREW	TE 8 x 12 UNI 5739		
14	61004700	6	RONDELLA	RONDELLE	SCHEIBE	WASHER	PIANA Ø 8 UNI 6592		
15	62010400	4	DADO	ECROU	MUTTER	NUT	M 10 x 1,5 AUTOBLOCC.		
16	61004900	4	RONDELLA	RONDELLE	SCHEIBE	WASHER	PIANA Ø 10 UNI 6592		
17	45194700	1	CONTROPIASTRA	CONTRE-PLAQUE	GEGENPLATTE	COUNTER PLATE			

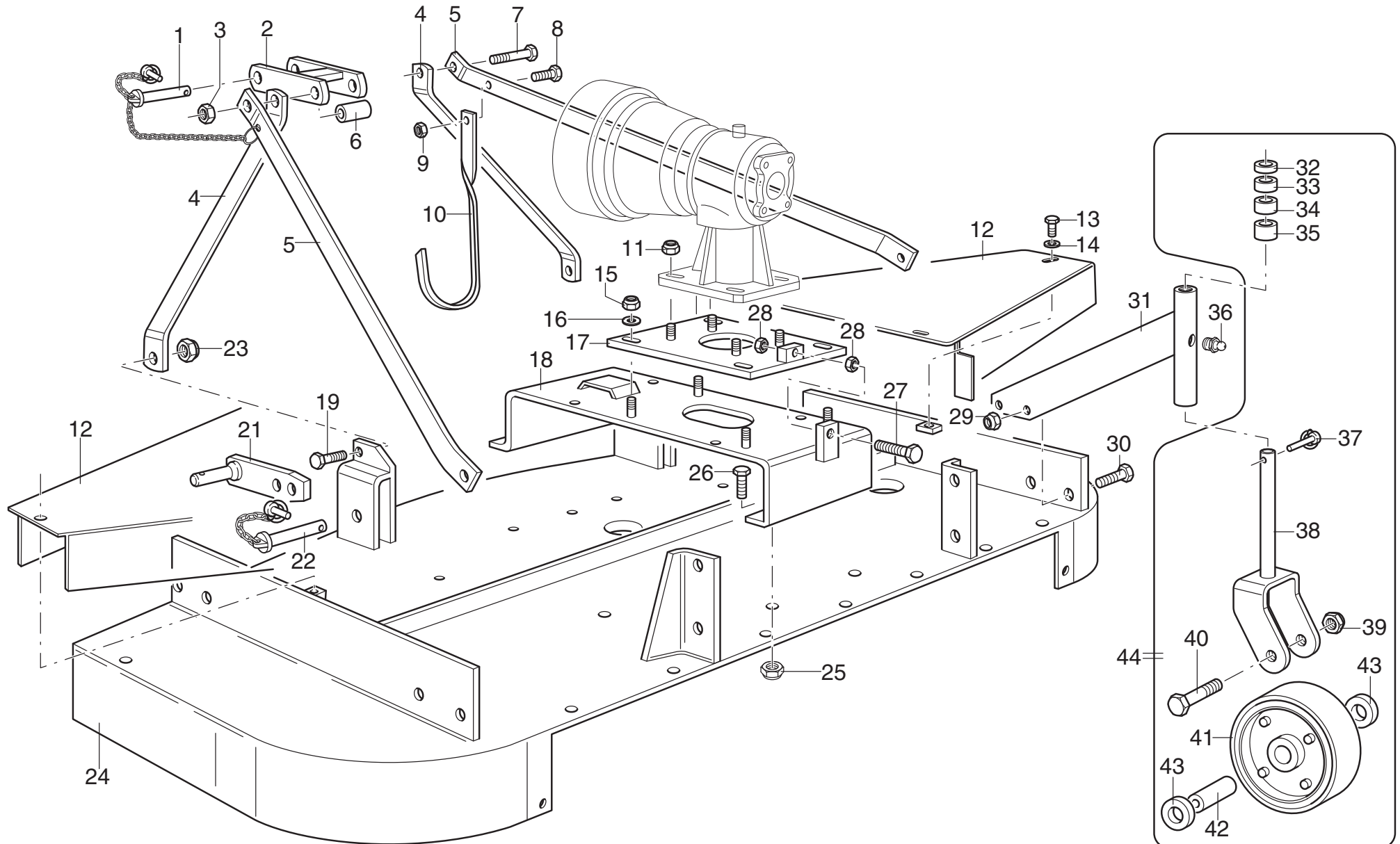

MURATORI MR

TAV. 1.0

POS.	N° CODICE	Q.	DESCRIZIONE	DESIGNATION	BENENNUNG	DESCRIPTION	DESIGNAZIONE	Da matr. De nr. serie Vom Seriennr. From serial nr.	Fino matr. Jusqu'au nr. serie Bis Seriennr. Up to serial nr.
18	40233900	1	SUPPORTO	SUPPORT	HALTERUNG	SUPPORT	120		
18	40234000	1	SUPPORTO	SUPPORT	HALTERUNG	SUPPORT	150-180		
19	60021200	4	VITE	VIS	SCHRAUBE	SCREW	TE 12 x 35 UNI 5739 8.8 ZNT		
21	40239400	2	BRACCIO	BRAS	ARM	ARM			
22	38024100	2	PERNO	PIVOT	BOLZEN	PIN			
23	62010600	4	DADO	ECROU	MUTTER	NUT	M 12 x 1.75 AUTOBLOCC.		
24	41111300	1	TELAIO	CHASSIS	RAHMEN	FRAME	120		
24	41122800	1	TELAIO	CHASSIS	RAHMEN	FRAME	135		
24	41111400	1	TELAIO	CHASSIS	RAHMEN	FRAME	150		
24	41111500	1	TELAIO	CHASSIS	RAHMEN	FRAME	180		
24	41122900	1	TELAIO	CHASSIS	RAHMEN	FRAME	210		
25	62010400	2	DADO	ECROU	MUTTER	NUT	M 10 x 1.5 AUTOBLOCC.		
26	60017900	5	VITE	VIS	SCHRAUBE	SCREW	TE 10 x 25 UNI 5739 8.8 ZNT		
27	60030200	1	VITE	VIS	SCHRAUBE	SCREW	TE 10 x 80 UNI 5739		
28	62007000	2	DADO	ECROU	MUTTER	NUT	M 10 x 1.5 UNI 5588		
29	62010600	8	DADO	ECROU	MUTTER	NUT	M 12 x 1.75 AUTOBLOCC.		
30	60028200	8	VITE	VIS	SCHRAUBE	SCREW	TE 12 x 40 UNI 5739 8.8 ZNT		
31	40234200	4	STAFFA	BRIDE	BÜGEL	BRACKET			
32	32174600	4	SPESSORE	EPAISSEUR	BEILAGERING	SPACER	H = 6		
33	32174700	4	SPESSORE	EPAISSEUR	BEILAGERING	SPACER	H = 12		
34	32174900	4	SPESSORE	EPAISSEUR	BEILAGERING	SPACER	H = 24		
35	32175000	4	SPESSORE	EPAISSEUR	BEILAGERING	SPACER	H = 32		
36	64000200	4	INGRASSATORE	GRAISSEUR	SCHMIERNIPPEL	GREASE FITTING	M 6 x 1		
37	64004800	4	SPINA	GOUPILLE	STIFT	PIN	Ø 8		
38	40234300	4	FORCELLA	FOURCHE	GABEL	YOKE			
39	62010600	4	DADO	ECROU	MUTTER	NUT	M 12 x 1.75 AUTOBLOCC.		

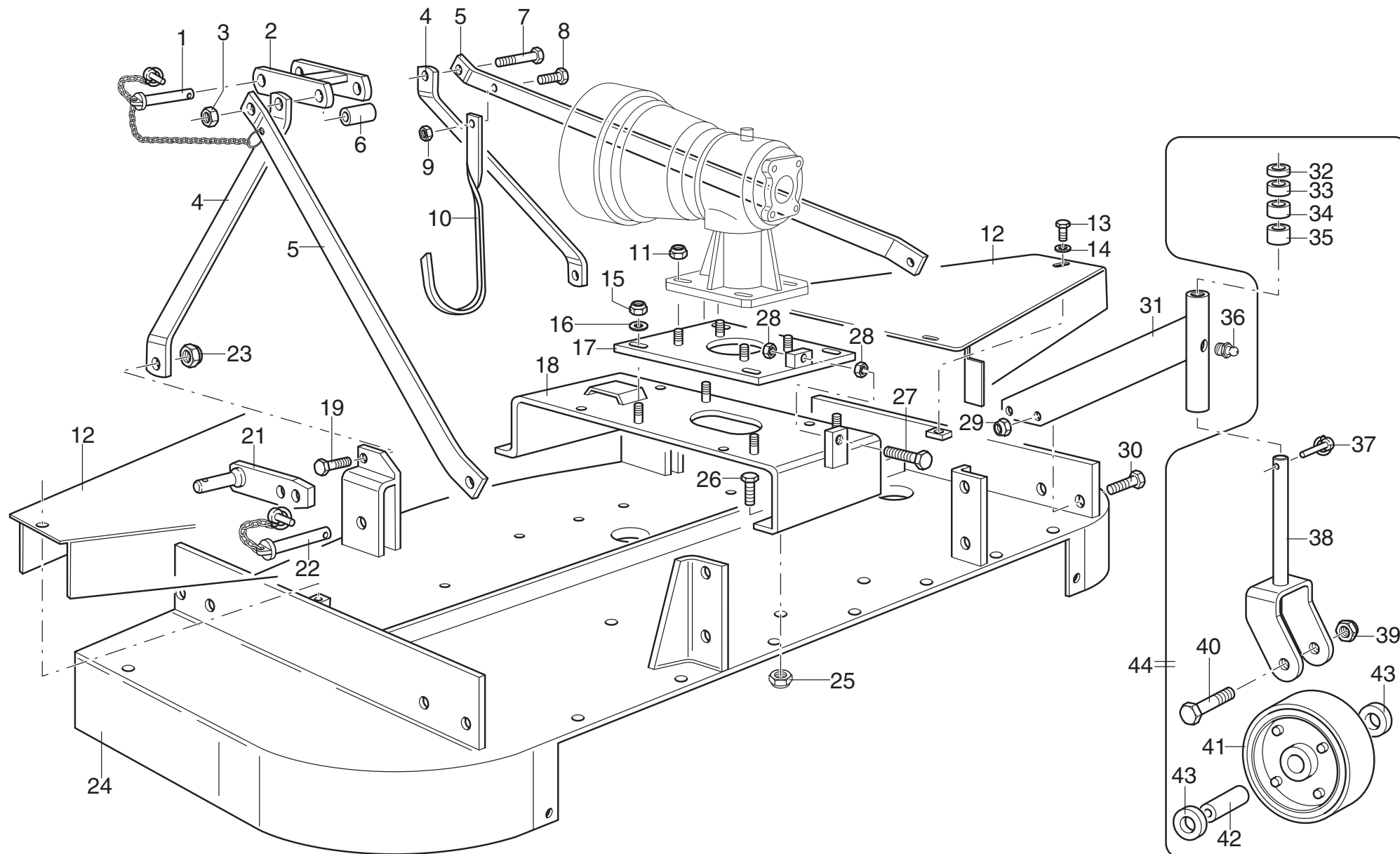

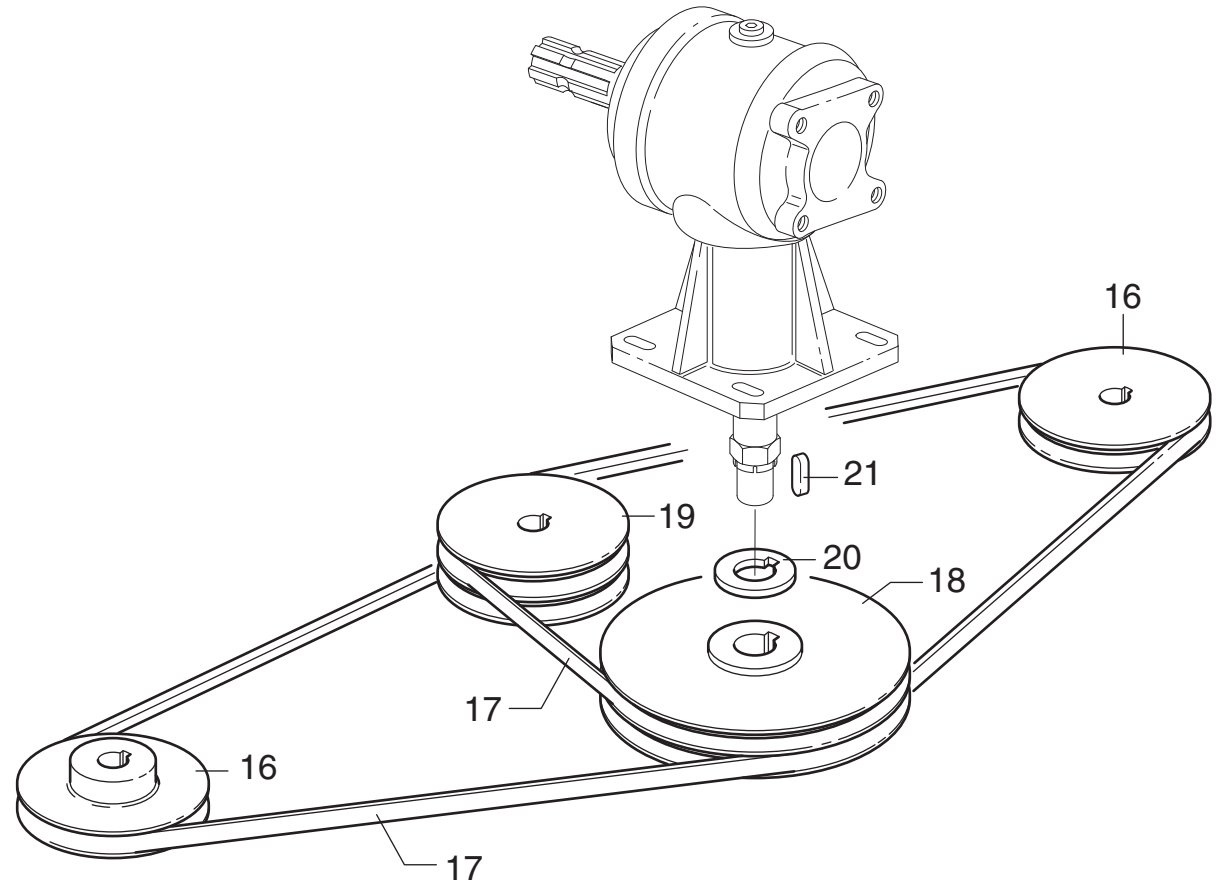
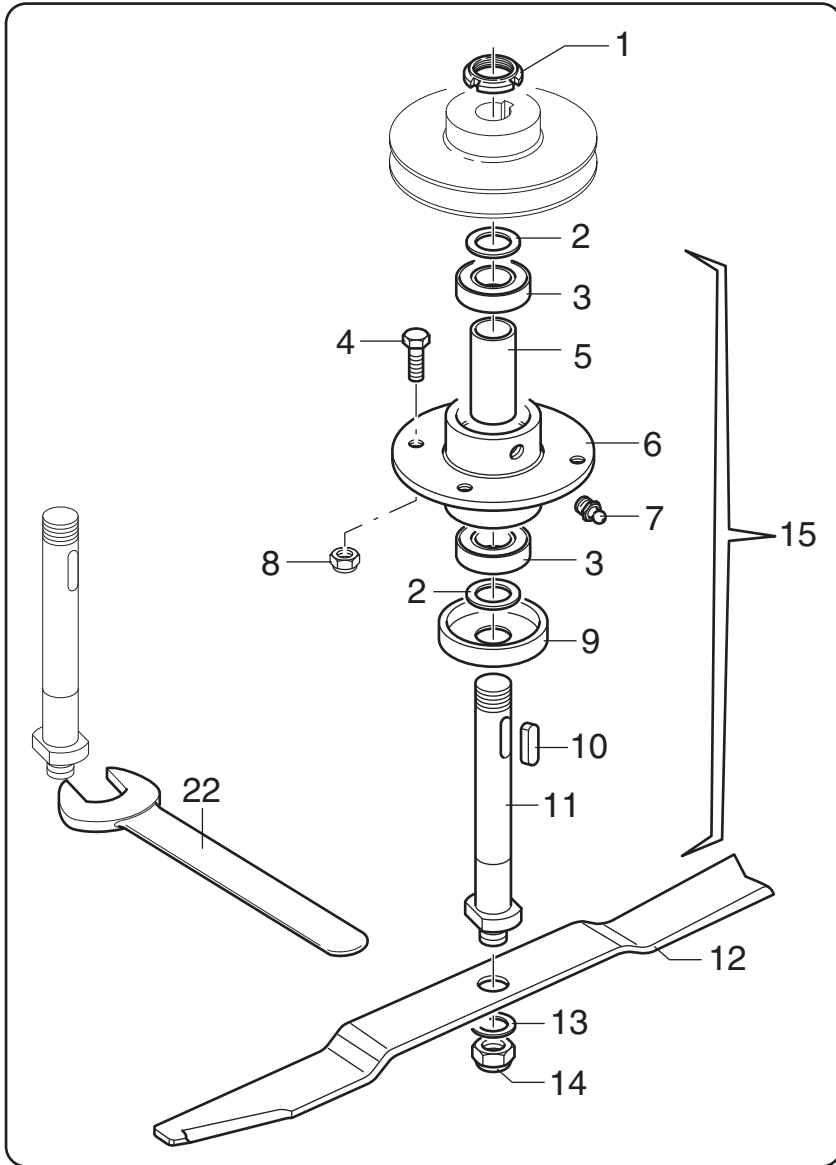

MURATORI MR

TAV. 2.0

POS.	N° CODICE	Q.	DESCRIZIONE	DESIGNATION	BENENNUNG	DESCRIPTION	DESIGNAZIONE	Da matr. De nr. serie Vom Seriennr. From serial nr.	Fino matr. Jusqu'au nr. serie Bis Seriennr. Up to serial nr.
1	62001200	3	GHIERA	FRETTE	NUTMUTTER	RING NUT	M 25 x 1.5 AUTOBLOCC.		
2	32174100	6	SPESSORE	EPAISSEUR	BEILAGERING	SPACER			
3	67016600	6	CUSCINETTO	ROULEMENT	LAGER	BEARING	6205 RS		
4	60021300	12	VITE	VIS	SCHRAUBE	SCREW	TE 10 x 30 UNI 5739 8.8 ZNT		
5	32174000	3	DISTANZIALE	ENTRETOISE	DISTANZSTÜCK	SPACER			
6	40234100	3	SUPPORTO	SUPPORT	HALTERUNG	SUPPORT			
7	64001800	3	INGRASSATORE	GRAISSEUR	SCHMIERNIPPEL	GREASE FITTING	M 10 x 1 DIRITTO		
8	62010400	12	DADO	ECROU	MUTTER	NUT	M 10 x 1.5 AUTOBLOCC.		
9	39261100	3	PROTEZIONE	PROTECTION	SCHUTZ	GUARD			
10	65001100	3	LINGUETTA	CLAVETTE	FEDER	KEY	8 x 7 x 30 UNI 6604		
11	31078600	3	ALBERO	ARBRE	WELLE	SHAFT			
12	12017700	3	LAMA	LAME DE COUPE	SCHNEIDKANTE	BLADE	120		
12	12021200	3	LAMA	LAME DE COUPE	SCHNEIDKANTE	BLADE	135		
12	12017800	3	LAMA	LAME DE COUPE	SCHNEIDKANTE	BLADE	150		
12	12017900	3	LAMA	LAME DE COUPE	SCHNEIDKANTE	BLADE	180		
12	12021300	3	LAMA	LAME DE COUPE	SCHNEIDKANTE	BLADE	210		
13	39077800	3	RONDELLA	RONDELLE	SCHEIBE	WASHER	PIANA Øi 19 Øe 50 SP5		
14	62011100	3	DADO	ECROU	MUTTER	NUT	M 18 x 1.5 AUTOBLOCC.		
15	45115100		MOZZO COMPLETO	ENSEMBLE MOYEU	SATZ NABE	SPINDLE ASSEMBLY			
16	68086600	2	PULEGGIA	POULIE	RIEMENSCHLEIBE	PULLEY	120		
16	68112500	2	PULEGGIA	POULIE	RIEMENSCHLEIBE	PULLEY	135		
16	68086700	2	PULEGGIA	POULIE	RIEMENSCHLEIBE	PULLEY	150-180-210		
17	68083500	2	CINGHIA	COURROIE	KEILRIEMEN	BELT	XPB1320 (120)		
17	68113000	2	CINGHIA	COURROIE	KEILRIEMEN	BELT	B56 (135)		
17	68086900	2	CINGHIA	COURROIE	KEILRIEMEN	BELT	B67 (150)		
17	68087000	2	CINGHIA	COURROIE	KEILRIEMEN	BELT	B74 (180)		

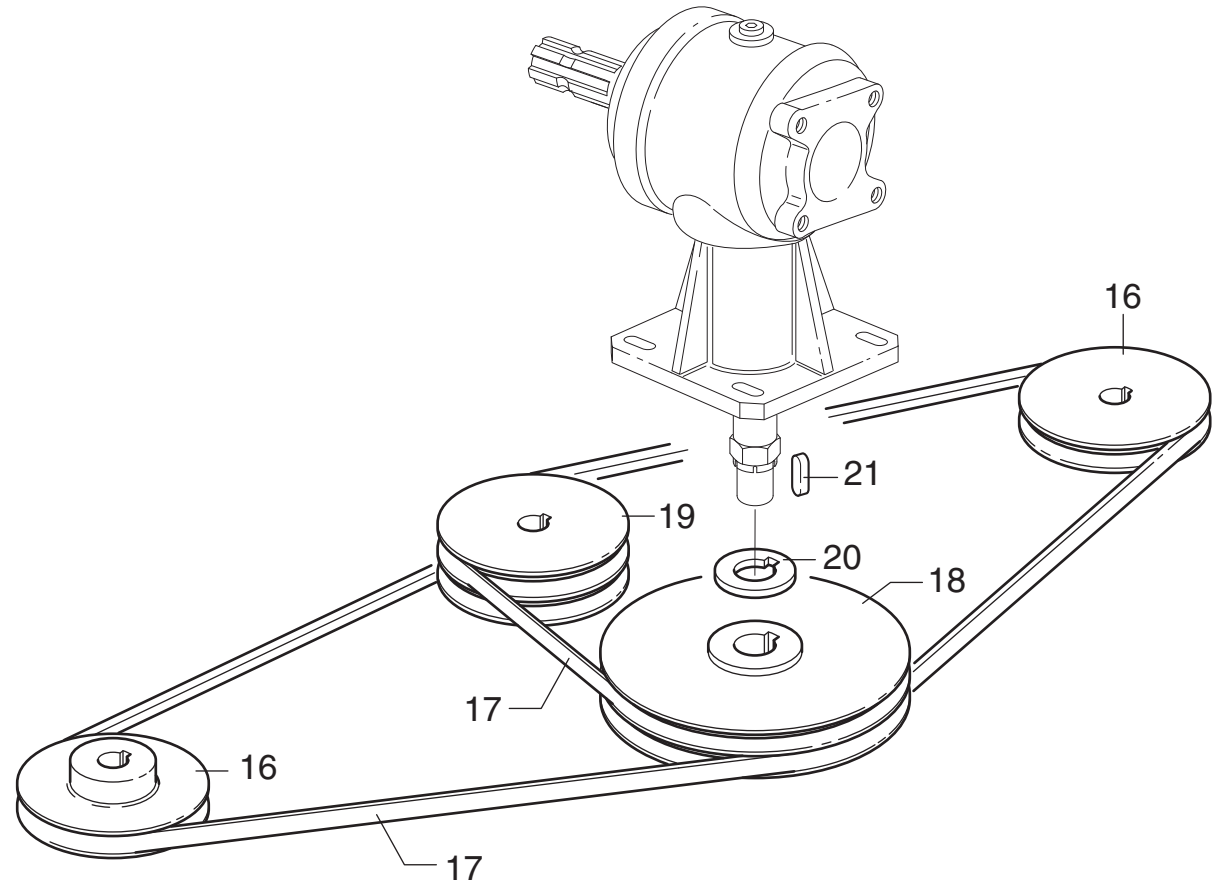
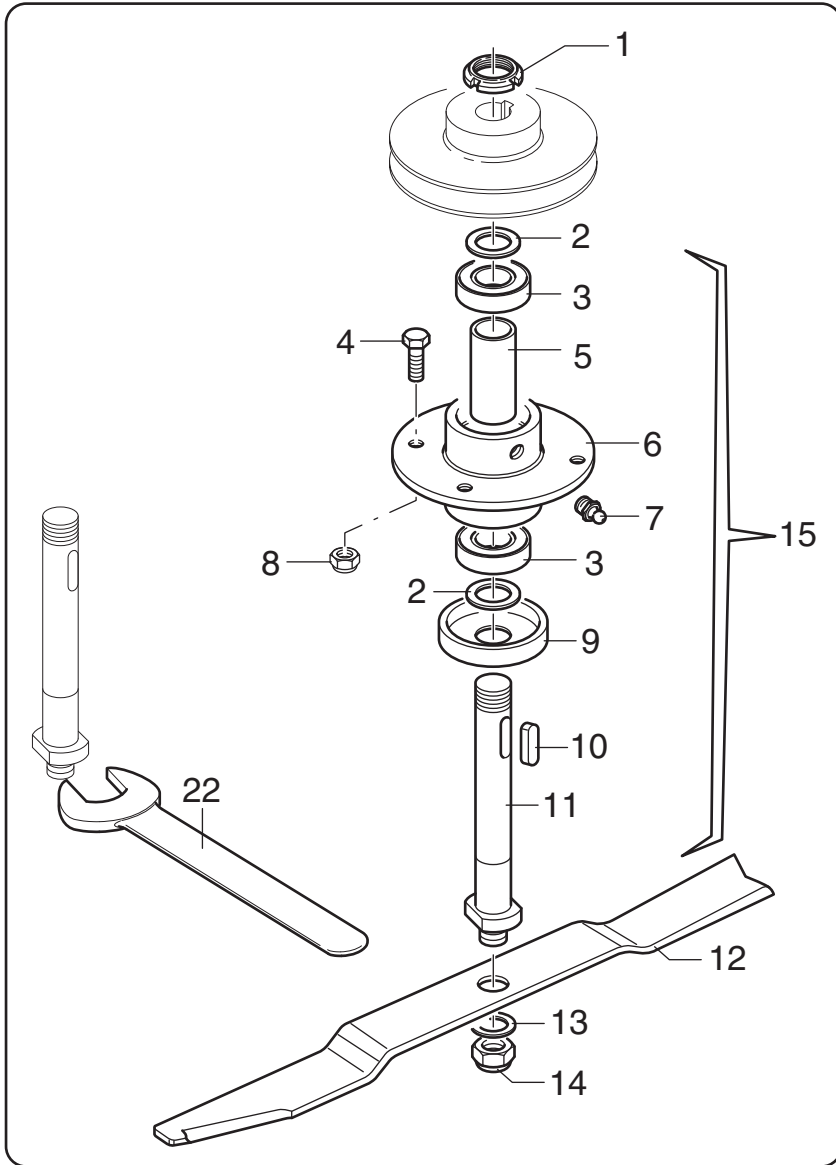

FINO MATR. 85719 - JUSQU'AU NR. SERIE 85719 - BIS SERIENNR. 85719 - UP TO SERIAL NR. 85719

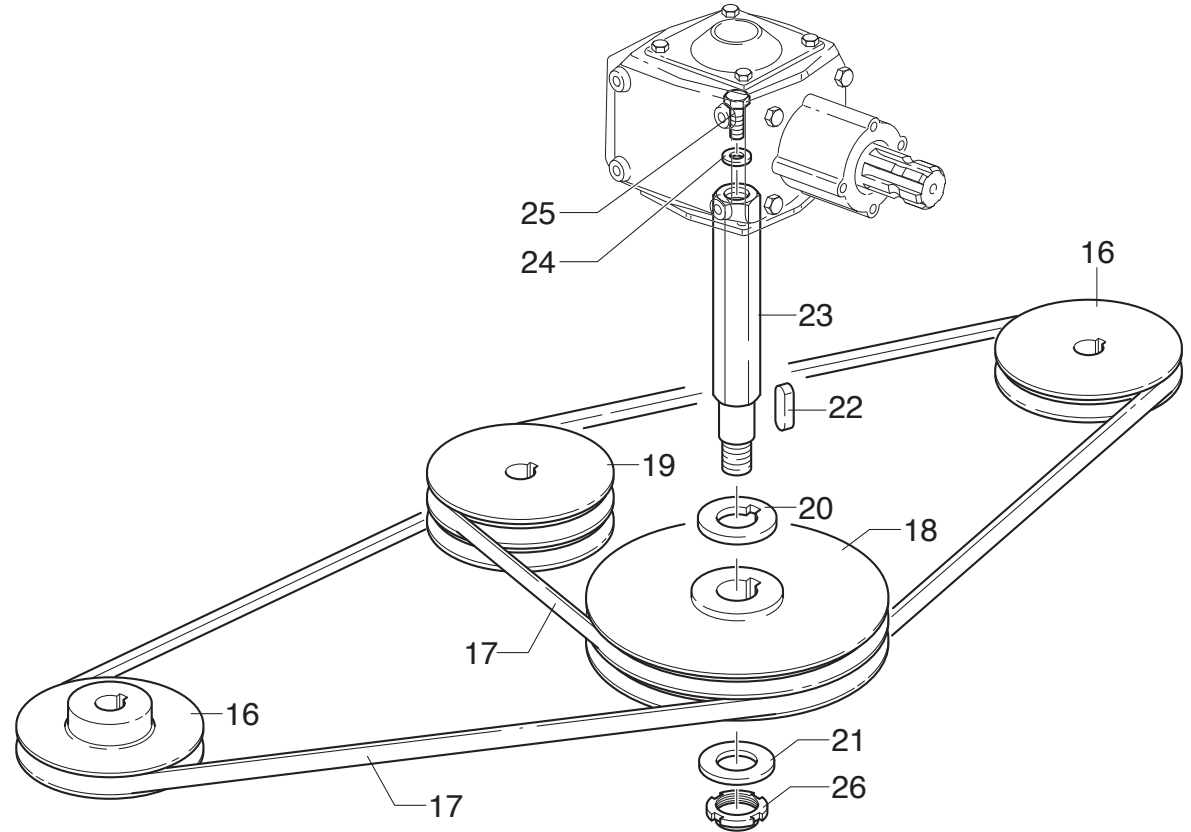
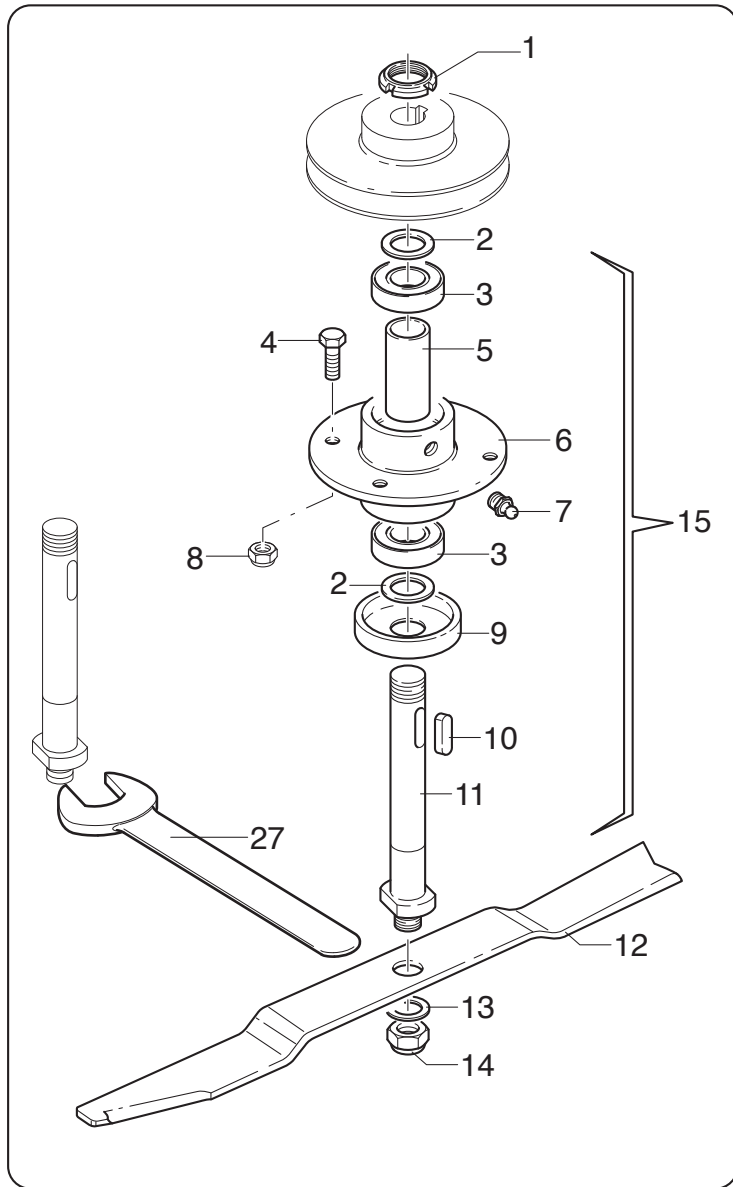

MURATORI MR

TAV. 2.1

POS.	N° CODICE	Q.	DESCRIZIONE	DESIGNATION	BENENNUNG	DESCRIPTION	DESIGNAZIONE	Da matr. De nr. serie Vom Seriennr. From serial nr.	Fino matr. Jusqu'au nr. serie Bis Seriennr. Up to serial nr.
1	62001200	3	GHIERA	FRETTE	NUTMUTTER	RING NUT	M 25 x 1.5 AUTOBLOCC.		
2	32174100	6	SPESSORE	EPAISSEUR	BEILAGERING	SPACER			
3	67016600	6	CUSCINETTO	ROULEMENT	LAGER	BEARING	6205 RS		
4	60021300	12	VITE	VIS	SCHRAUBE	SCREW	TE 10 x 30 UNI 5739 8.8 ZNT		
5	32174000	3	DISTANZIALE	ENTRETOISE	DISTANZSTÜCK	SPACER			
6	40234100	3	SUPPORTO	SUPPORT	HALTERUNG	SUPPORT			
7	64001800	3	INGRASSATORE	GRAISSEUR	SCHMIERNIPPEL	GREASE FITTING	M 10 x 1 DIRITTO		
8	62010400	12	DADO	ECROU	MUTTER	NUT	M 10 x 1.5 AUTOBLOCC.		
9	39261100	3	PROTEZIONE	PROTECTION	SCHUTZ	GUARD			
10	65001100	3	LINGUETTA	CLAVETTE	FEDER	KEY	8 x 7 x 30 UNI 6604		
11	31078600	3	ALBERO	ARBRE	WELLE	SHAFT			
12	12017700	3	LAMA	LAME DE COUPE	SCHNEIDKANTE	BLADE	120		
12	12017800	3	LAMA	LAME DE COUPE	SCHNEIDKANTE	BLADE	150		
12	12017900	3	LAMA	LAME DE COUPE	SCHNEIDKANTE	BLADE	180		
13	39077800	3	RONDELLA	RONDELLE	SCHEIBE	WASHER	PIANA Øi 19 Øe 50		
14	62011100	3	DADO	ECROU	MUTTER	NUT	M 18 x 1.5 AUTOBLOCC.		
15	45115100		MOZZO COMPLETO	ENSEMBLE MOYEU	SATZ NABE	SPINDLE ASSEMBLY			
16	68086600	2	PULEGGIA	POULIE	RIEMENSCHLEIBE	PULLEY	120		
16	68086700	2	PULEGGIA	POULIE	RIEMENSCHLEIBE	PULLEY	150-180		
17	68083500	2	CINGHIA	COURROIE	KEILRIEMEN	BELT	XPB1320 (120)		
17	68086900	2	CINGHIA	COURROIE	KEILRIEMEN	BELT	B67 (150)		
17	68087000	2	CINGHIA	COURROIE	KEILRIEMEN	BELT	B74 (180)		
18	68086100	1	PULEGGIA	POULIE	RIEMENSCHLEIBE	PULLEY	120		
18	68086200	1	PULEGGIA	POULIE	RIEMENSCHLEIBE	PULLEY	150		
18	68086300	1	PULEGGIA	POULIE	RIEMENSCHLEIBE	PULLEY	180		
19	68086400	1	PULEGGIA	POULIE	RIEMENSCHLEIBE	PULLEY	120		

FINO MATR. 85719 - JUSQU'AU NR. SERIE 85719 - BIS SERIENNR. 85719 - UP TO SERIAL NR. 85719

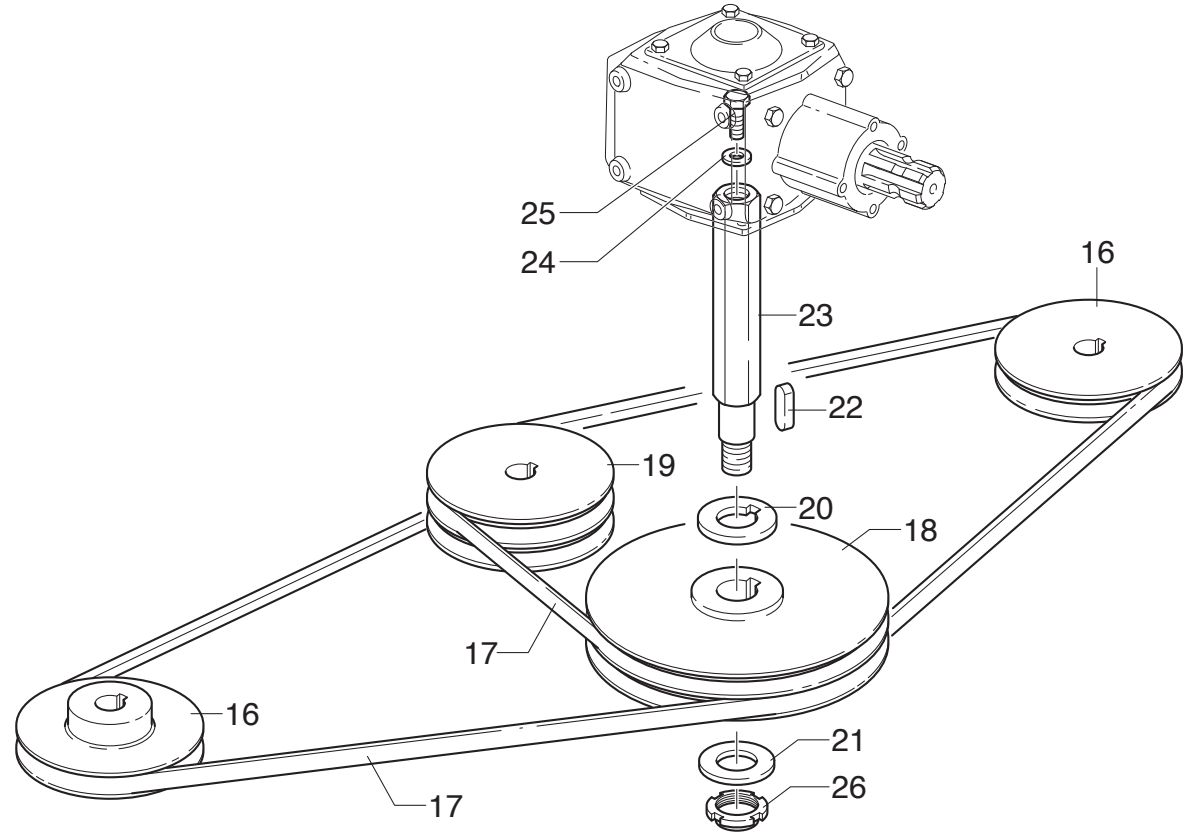
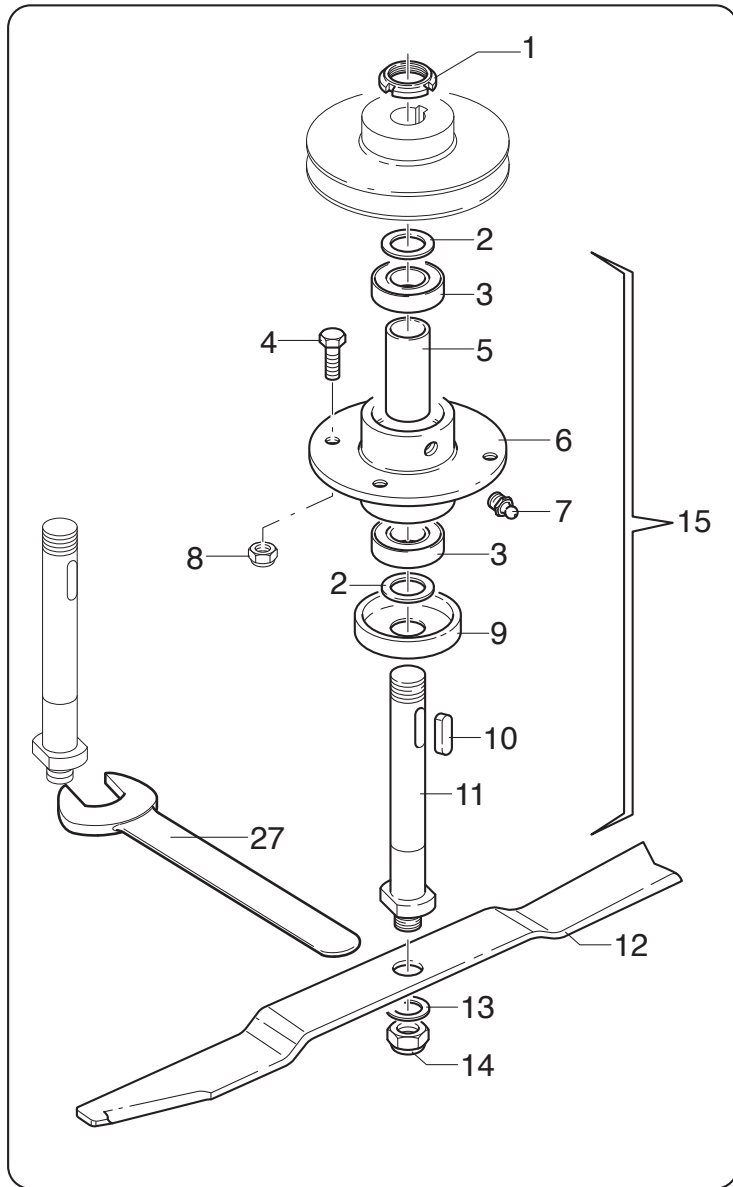

DA MATR. 85720 - A PARTIR DE NR. SERIE 85720 - VOM SERIENNR. 85720 - FROM SERIAL NR. 85720

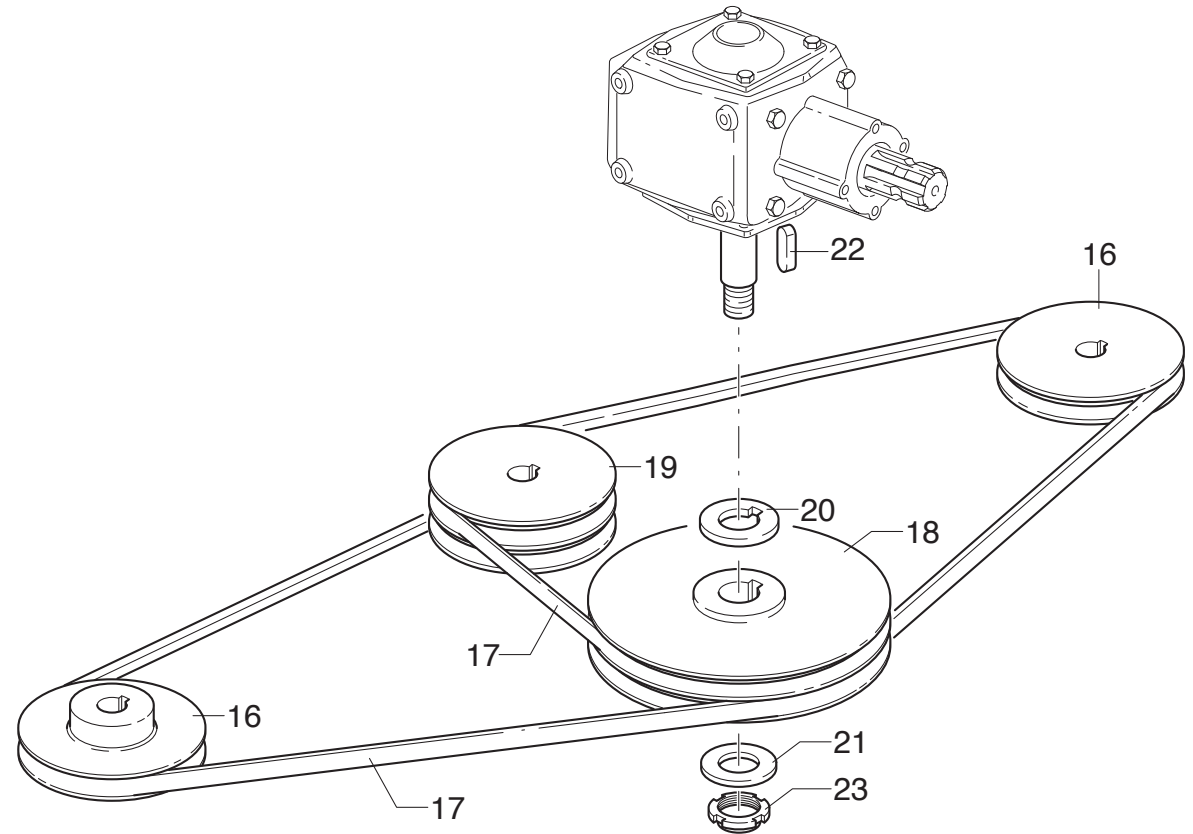
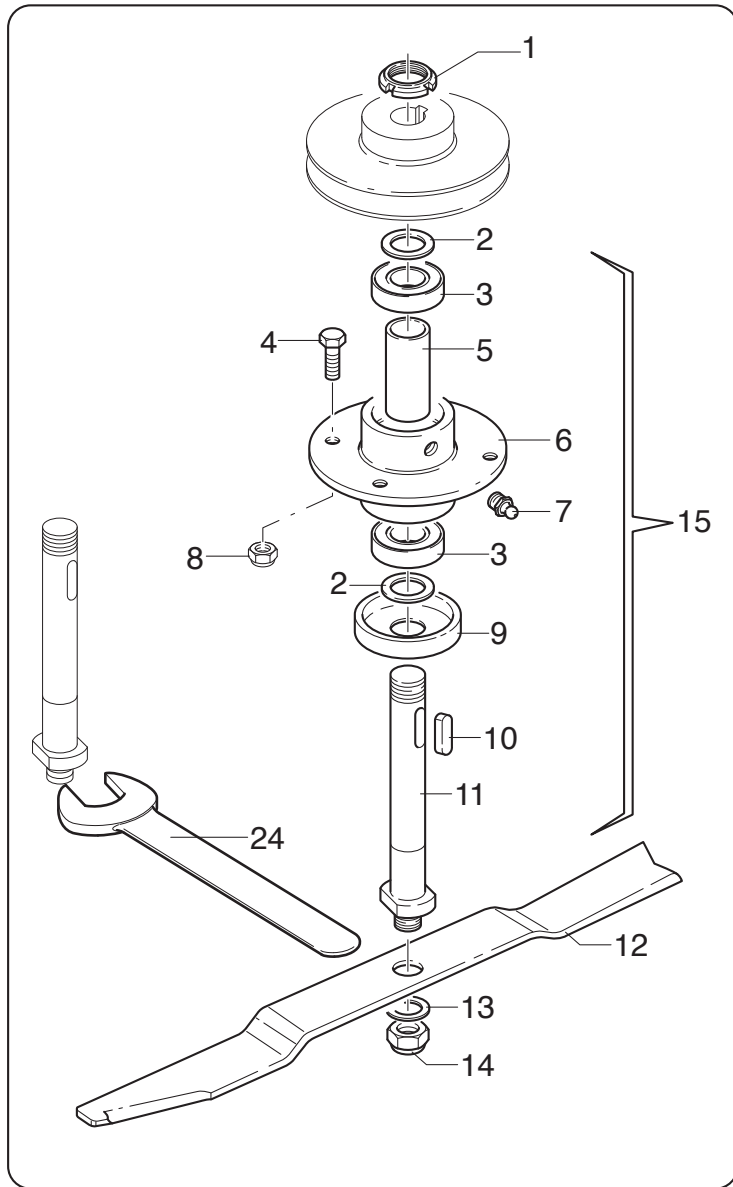

MURATORI MR

TAV. 2.2

POS.	N° CODICE	Q.	DESCRIZIONE	DESIGNATION	BENENNUNG	DESCRIPTION	DESIGNAZIONE	Da matr. De nr. serie Vom Seriennr. From serial nr.	Fino matr. Jusqu'au nr. serie Bis Seriennr. Up to serial nr.
1	62001200	3	GHIERA	FRETTE	NUTMUTTER	RING NUT	M 25 x 1.5 AUTOBLOCC.		
2	32174100	6	SPESSORE	EPAISSEUR	BEILAGERING	SPACER			
3	67016600	6	CUSCINETTO	ROULEMENT	LAGER	BEARING	6205 RS		
4	60021300	12	VITE	VIS	SCHRAUBE	SCREW	TE 10 x 30 UNI 5739 8.8 ZNT		
5	32174000	3	DISTANZIALE	ENTRETOISE	DISTANZSTÜCK	SPACER			
6	40234100	3	SUPPORTO	SUPPORT	HALTERUNG	SUPPORT			
7	64001800	3	INGRASSATORE	GRAISSEUR	SCHMIERNIPPEL	GREASE FITTING	M 10 x 1 DIRITTO		
8	62010400	12	DADO	ECROU	MUTTER	NUT	M 10 x 1.5 AUTOBLOCC.		
9	39261100	3	PROTEZIONE	PROTECTION	SCHUTZ	GUARD			
10	65001100	3	LINGUETTA	CLAVETTE	FEDER	KEY	8 x 7 x 30 UNI 6604		
11	31078600	3	ALBERO	ARBRE	WELLE	SHAFT			
12	12017700	3	LAMA	LAME DE COUPE	SCHNEIDKANTE	BLADE	120		
12	12021200	3	LAMA	LAME DE COUPE	SCHNEIDKANTE	BLADE	135		
12	12017800	3	LAMA	LAME DE COUPE	SCHNEIDKANTE	BLADE	150		
12	12017900	3	LAMA	LAME DE COUPE	SCHNEIDKANTE	BLADE	180		
12	12021300	3	LAMA	LAME DE COUPE	SCHNEIDKANTE	BLADE	210		
13	39077800	3	RONDELLA	RONDELLE	SCHEIBE	WASHER	PIANA Øi 19 Øe 50		
14	62011100	3	DADO	ECROU	MUTTER	NUT	M 18 x 1.5 AUTOBLOCC.		
15	45115100		MOZZO COMPLETO	ENSEMBLE MOYEU	SATZ NABE	SPINDLE ASSEMBLY			
16	68086600	2	PULEGGIA	POULIE	RIEMENSCHLEIBE	PULLEY	120		
16	68112500	2	PULEGGIA	POULIE	RIEMENSCHLEIBE	PULLEY	135		
16	68086700	2	PULEGGIA	POULIE	RIEMENSCHLEIBE	PULLEY	150-180-210		
17	68083500	2	CINGHIA	COURROIE	KEILRIEMEN	BELT	XPB1320 (120)		
17	68113000	2	CINGHIA	COURROIE	KEILRIEMEN	BELT	B56 (135)		
17	68086900	2	CINGHIA	COURROIE	KEILRIEMEN	BELT	B67 (150)		
17	68087000	2	CINGHIA	COURROIE	KEILRIEMEN	BELT	B74 (180)		

DA MATR. 85720 - A PARTIR DE NR. SERIE 85720 - VOM SERIENNR. 85720 - FROM SERIAL NR. 85720

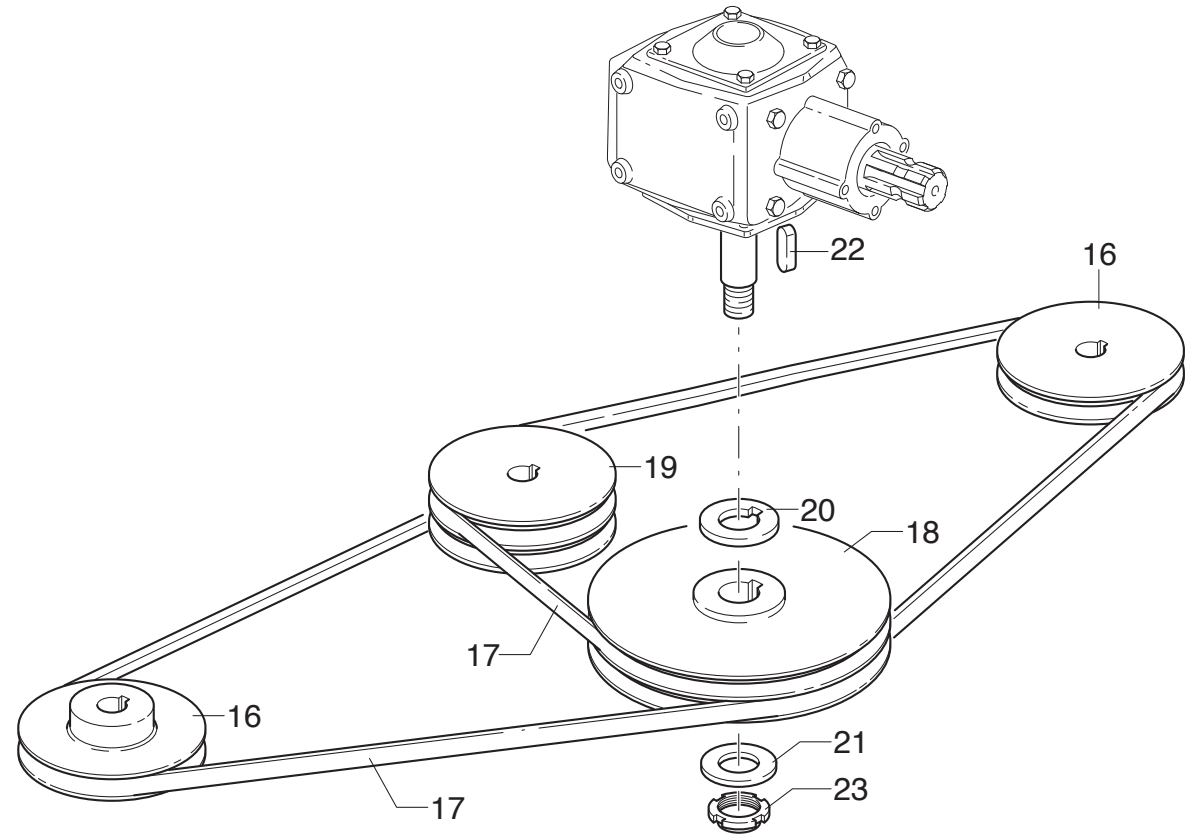
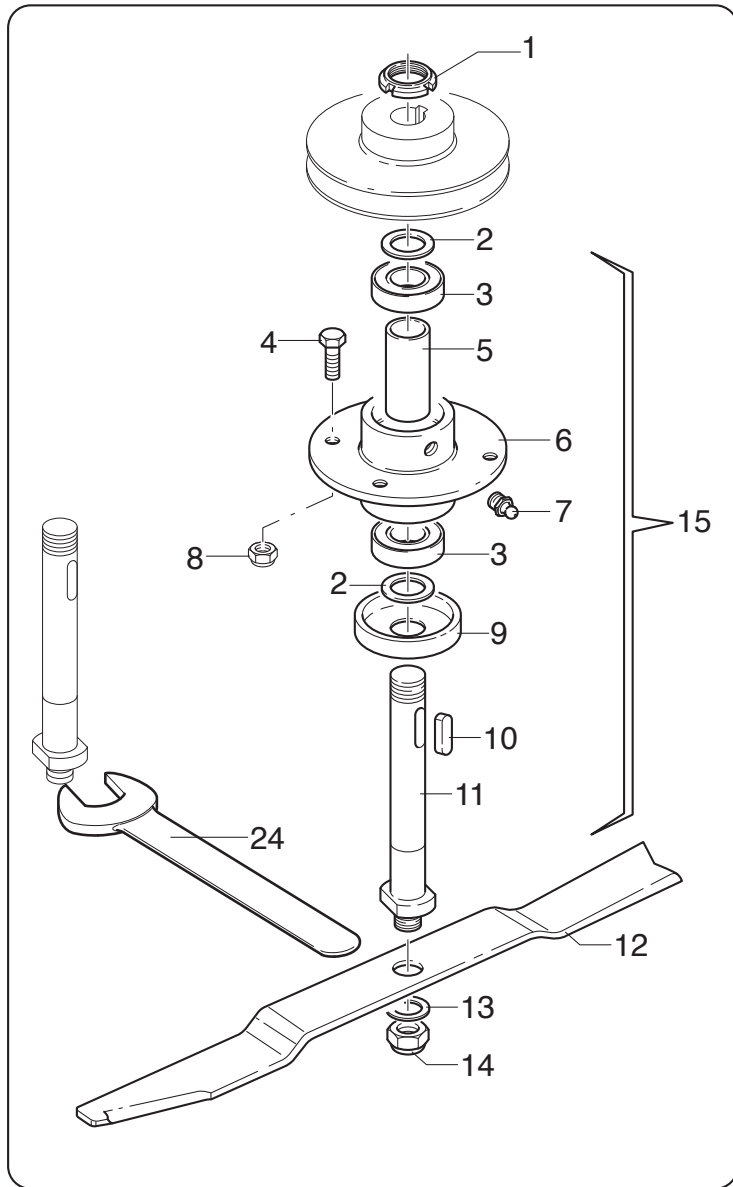

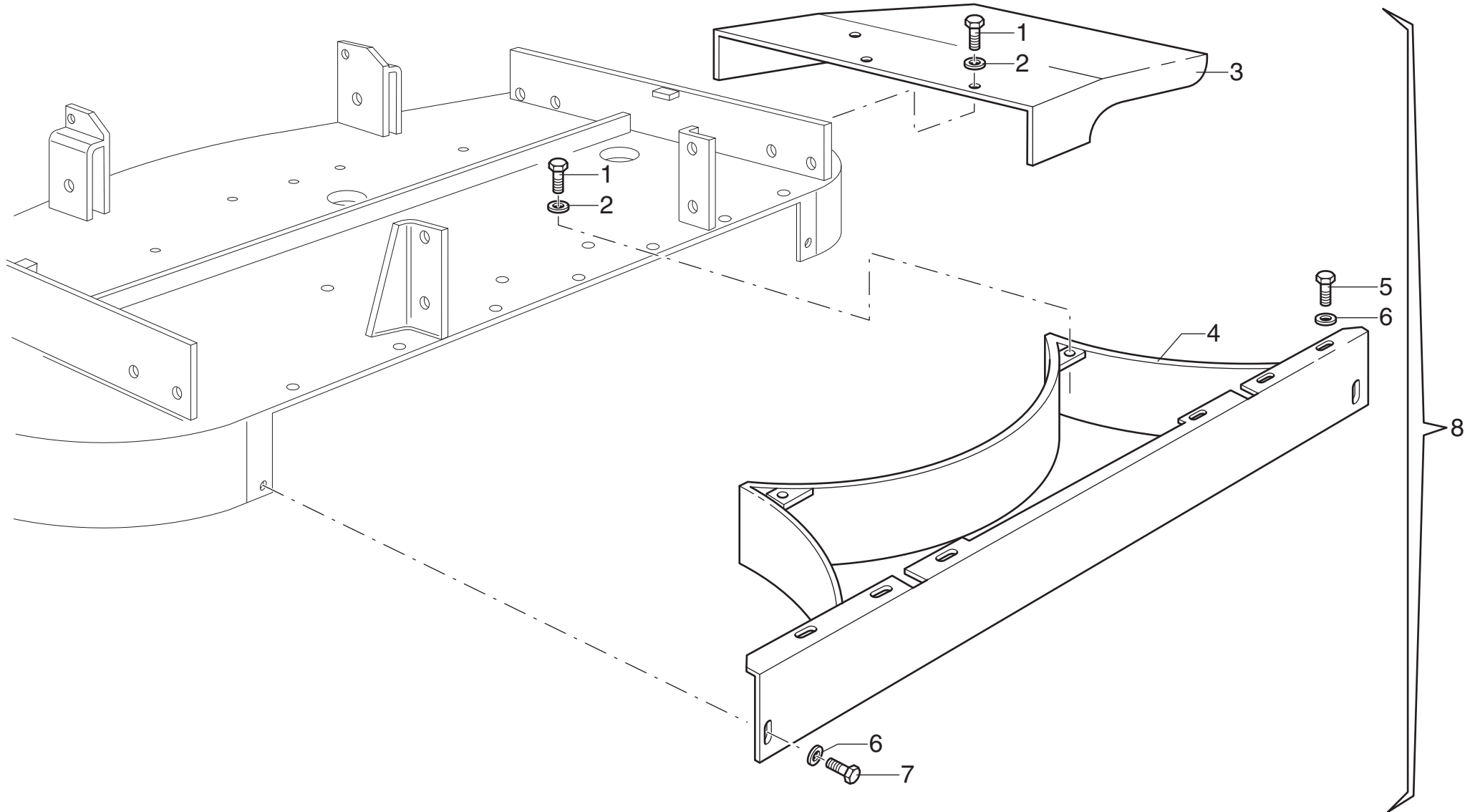

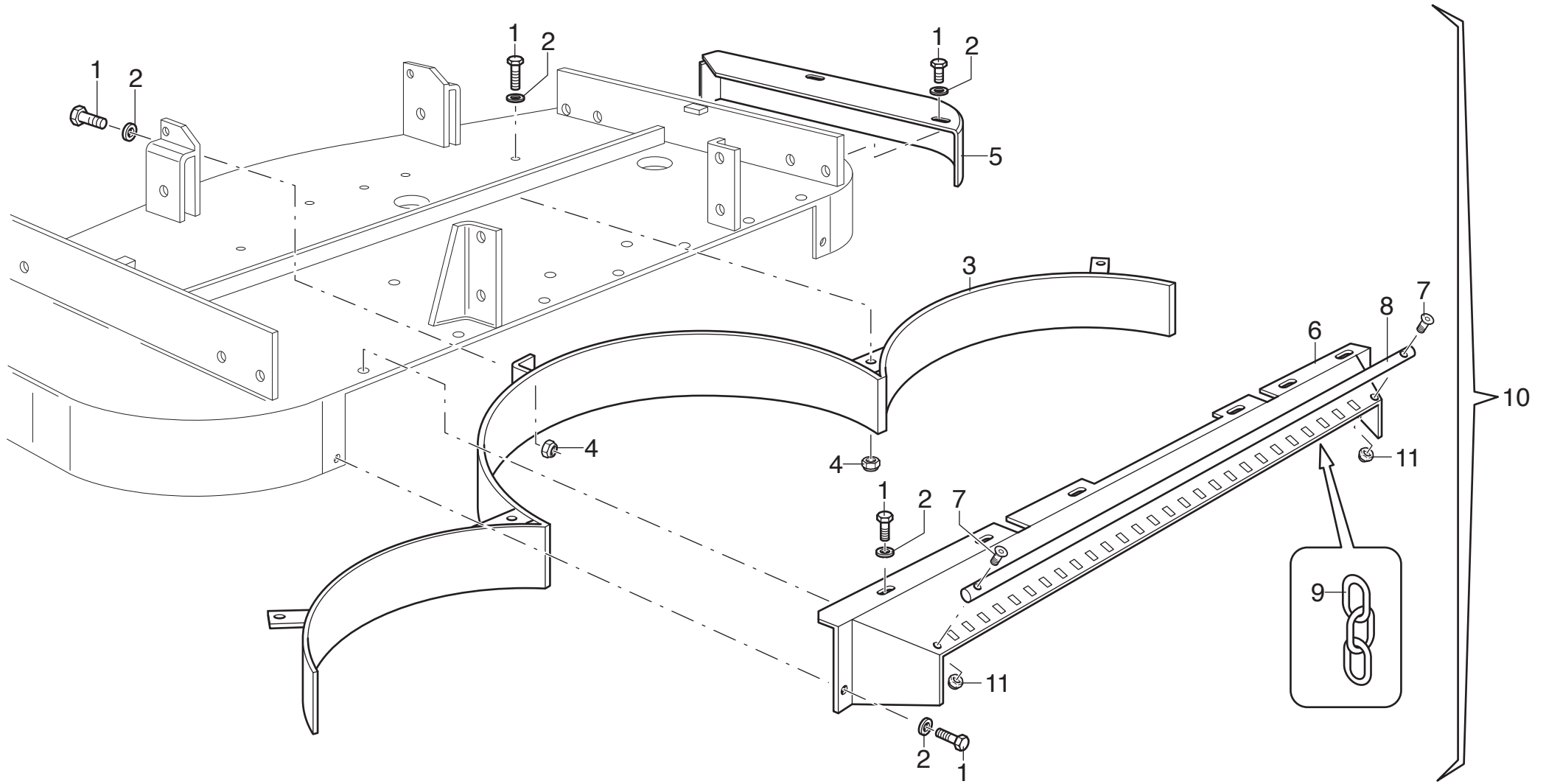

MURATORI MR

TAV. 4.0

POS.	N° CODICE	Q.	DESCRIZIONE	DESIGNATION	BENENNUNG	DESCRIPTION	DESIGNAZIONE	Da matr. De nr. serie Vom Seriennr. From serial nr.	Fino matr. Jusqu'au nr. serie Bis Seriennr. Up to serial nr.
1	60038700		VITE	VIS	SCHRAUBE	SCREW	TBCE 10 x 25 UNI 7380		
2	61004900		RONDELLA	RONDELLE	SCHEIBE	WASHER	PIANA Ø 10 UNI 6592		
3	40233500	1	DEFLETTORE	DEFLECTEUR	LEITBLECH	DEFLECTOR	120		
3	40298080	1	DEFLETTORE	DEFLECTEUR	LEITBLECH	DEFLECTOR	135		
3	40233600	1	DEFLETTORE	DEFLECTEUR	LEITBLECH	DEFLECTOR	150		
3	40233700	1	DEFLETTORE	DEFLECTEUR	LEITBLECH	DEFLECTOR	180		
3	40298100	1	DEFLETTORE	DEFLECTEUR	LEITBLECH	DEFLECTOR	210		
4	62010400	3	DADO	ECROU	MUTTER	NUT	M 10 x 1.5 AUTOBLOCC.		
5	40233200	1	CHIUSURA	FERMETURE	VERSCHLUSS	GRIPPING	120		
5	40297800	1	CHIUSURA	FERMETURE	VERSCHLUSS	GRIPPING	135		
5	40233300	1	CHIUSURA	FERMETURE	VERSCHLUSS	GRIPPING	150		
5	40233400	1	CHIUSURA	FERMETURE	VERSCHLUSS	GRIPPING	180		
5	40297900	1	CHIUSURA	FERMETURE	VERSCHLUSS	GRIPPING	210		
6	39260400	1	CONVOGLIATORE	CONVOYEUR	LEITBLECH	CONVEYOR	120		
6	39305400	1	CONVOGLIATORE	CONVOYEUR	LEITBLECH	CONVEYOR	135		
6	39260500	1	CONVOGLIATORE	CONVOYEUR	LEITBLECH	CONVEYOR	150		
6	39260600	1	CONVOGLIATORE	CONVOYEUR	LEITBLECH	CONVEYOR	180		
6	39305500	1	CONVOGLIATORE	CONVOYEUR	LEITBLECH	CONVEYOR	210		
7	60015700	2	VITE	VIS	SCHRAUBE	SCREW	TE 6 x 25 UNI 5739		
8	31078300	1	SPINA	GOUPILLE	STIFT	PIN	120		
8	31095000	1	SPINA	GOUPILLE	STIFT	PIN	135		
8	31078400	1	SPINA	GOUPILLE	STIFT	PIN	150		
8	31078500	1	SPINA	GOUPILLE	STIFT	PIN	180		
8	31095100	1	SPINA	GOUPILLE	STIFT	PIN	210		
9	68086000		CATENA	CHAINE	KETTE	CHAIN			
10	45113000		KIT SCARICO POSTERIORE	KIT DECHARG. ARRIERE	SATZ HECKAUSWURF	KIT REAR DISCHARGE	120		

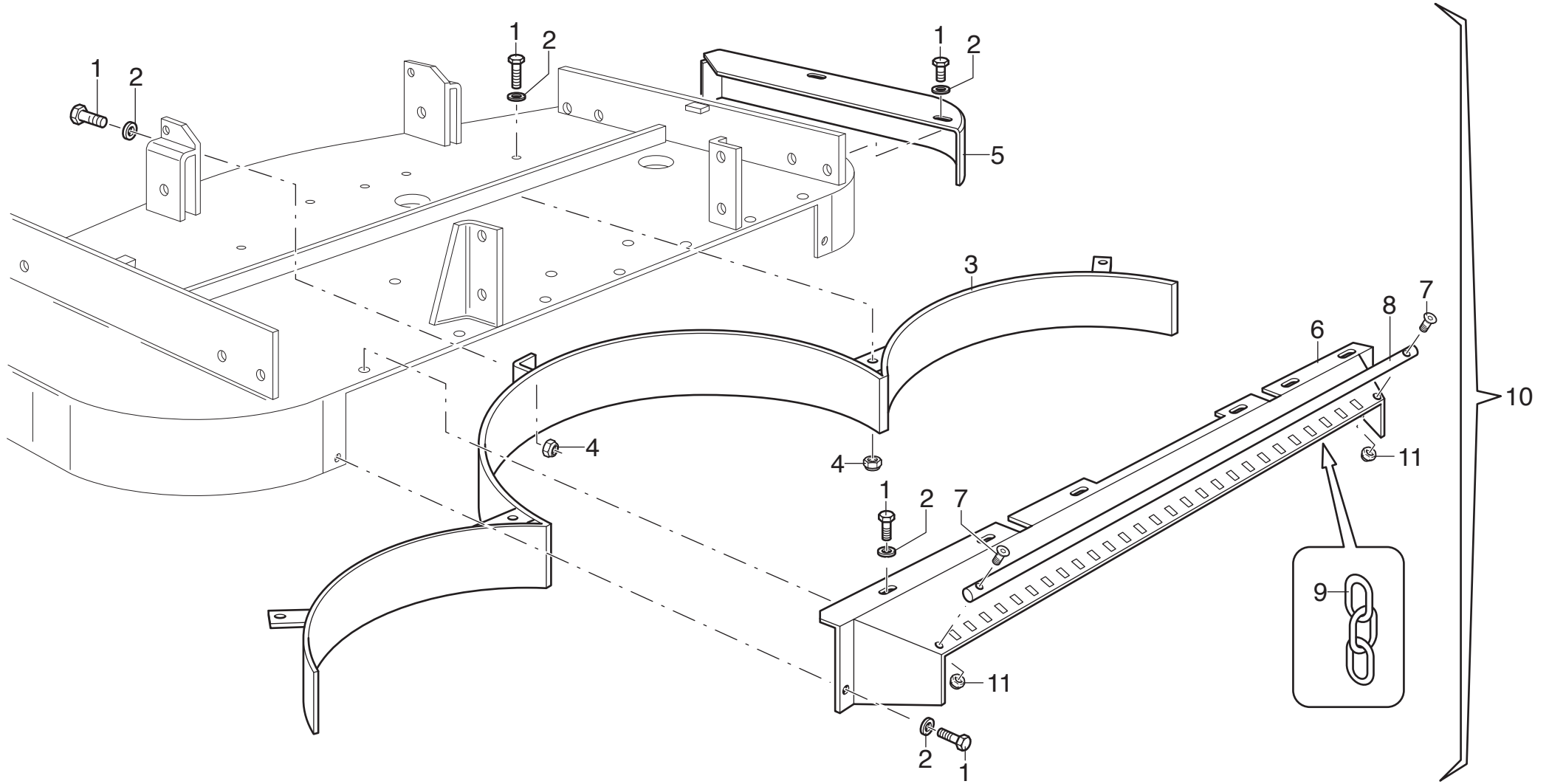



GRUPPO MOLTIPLICATORE - 540 RPM

ENSEMBLE MULTIPLICATEUR - 540 RPM

SATZ FÜR GETRIEBE - 540 UPM

KIT FOR GEAR BOX - 540 RPM

TAV. 5.0

MR

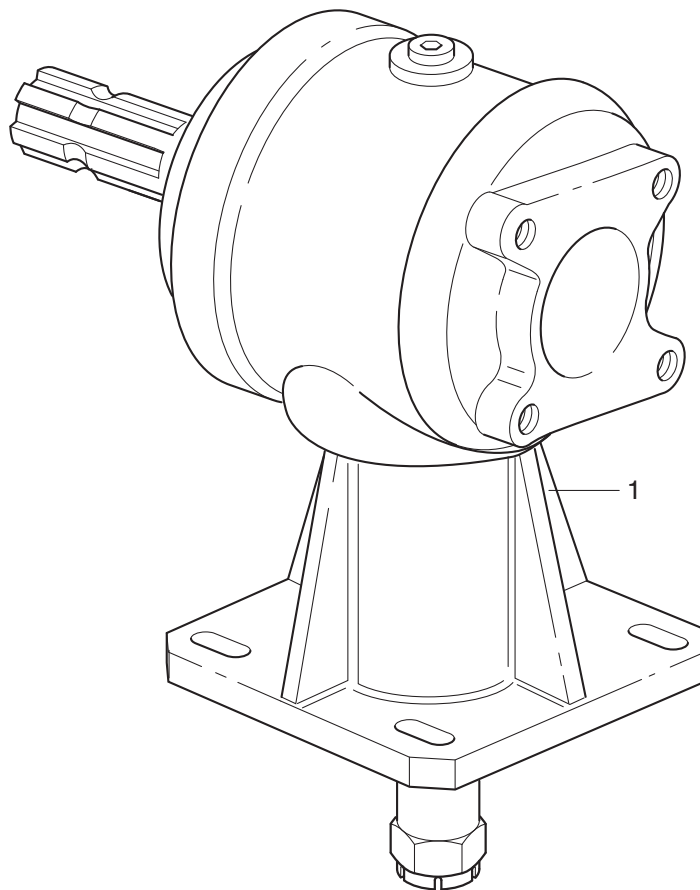

FINO MATR. 83556 - JUSQU'AU NR. SERIE 83556 - BIS SERIENNR. 83556 - UP TO SERIAL NR. 83556

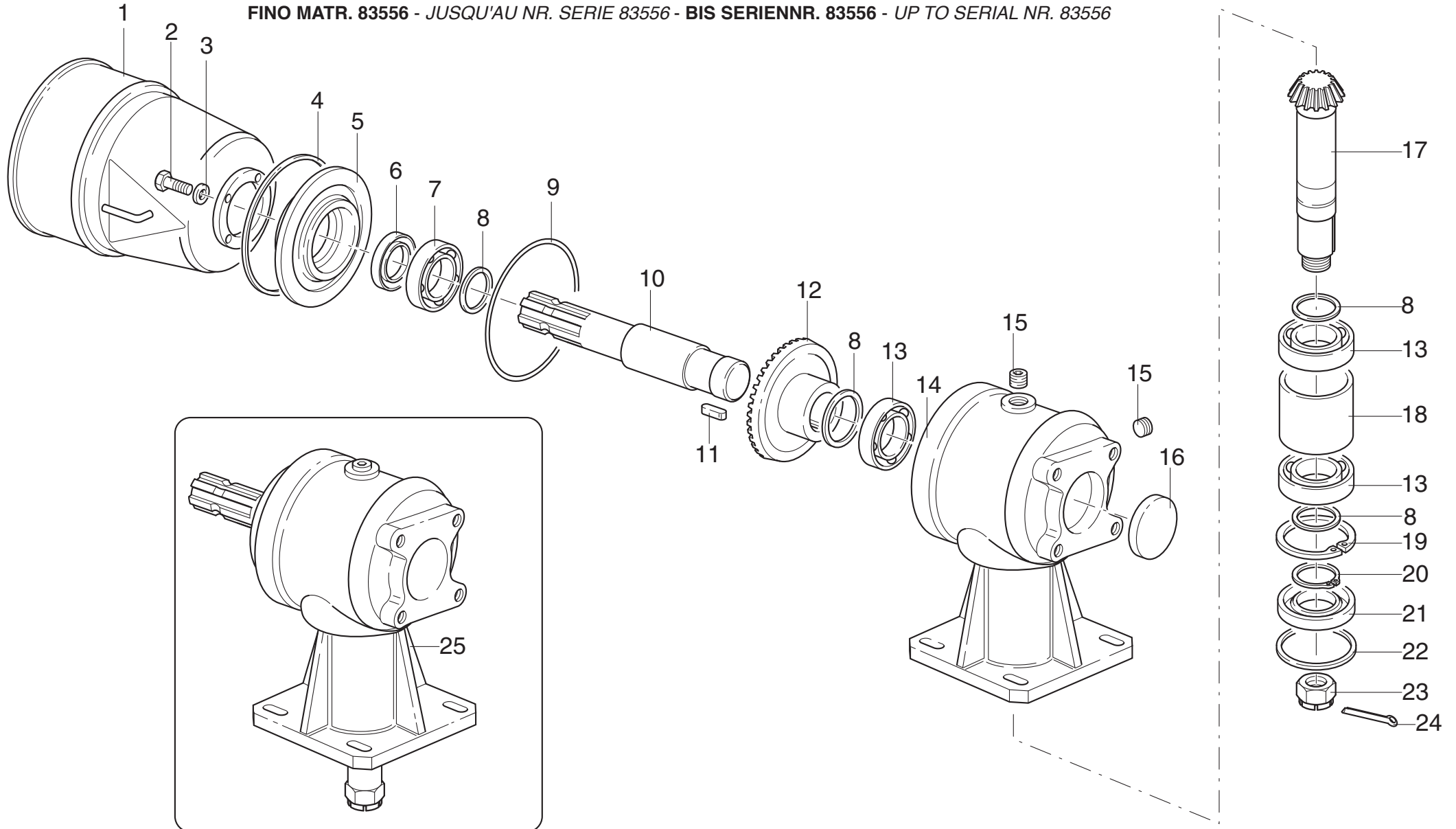

MURATORI MR

TAV. 5.2

POS.	N° CODICE	Q.	DESCRIZIONE	DESIGNATION	BENENNUNG	DESCRIPTION	DESIGNAZIONE	Da matr. De nr. serie Vom Seriennr. From serial nr.	Fino matr. Jusqu'au nr. serie Bis Seriennr. Up to serial nr.
1	68061501	1	PROTEZIONE	PROTECTION	SCHUTZ	GUARD			83556
2	60022800	4	VITE	VIS	SCHRAUBE	SCREW	TE 8 x 20 UNI 5739 8.8 ZNT		83556
3	61006200	4	RONDELLA	RONDELLE	SCHEIBE	WASHER	PIANA Øi 9 Øe 24 Sp.1,5		83556
4	63006300	1	ANELLO ELASTICO	BAGUE	SPANNRING	SNAP-RING	Ø 125 I UNI 7433		83556
5	01017800	1	FLANGIA	BRIDE	FLANSCH	FLANGE			83556
6	66001600	1	ANELLO TENUTA	JOINT D'ETANCHEITE	DICHTUNGSRING	JUNT RING	35 x 52 x 7		83556
7	67018500	1	CUSCINETTO	ROULEMENT	LAGER	BEARING	6007		83556
8	68052300		SPESSORE	EPAISSEUR	BEILAGERING	SPACER	35 x 48		83556
9	66009100	1	ANELLO TENUTA	JOINT D'ETANCHEITE	DICHTUNGSRING	JUNT RING	O. R. 4462		83556
10	31079400	1	ALBERO	ARBRE	WELLE	SHAFT			83556
11	65000600	1	LINGUETTA	CLAVETTE	FEDER	KEY	10 x 8 x 30		83556
12	10042800	1	CORONA	COURONNE	KRANZ	CROWN			83556
13	67003700	3	CUSCINETTO	ROULEMENT	LAGER	BEARING	6207		83556
14	01017700	1	SCATOLA	CARTER	GEHÄUSE	GEARBOX			83556
15	68008700	2	TAPPO	BOUCHON	STOPFEN	PLUG			83556
16	68087700	1	CAPPELOTTO	BOUCHON	ABSCHLUSSKAPPE	CAP NUT	52 x 7		83556
17	10042700	1	ALBERO	ARBRE	WELLE	SHAFT			83556
18	32176100	1	DISTANZIALE	ENTRETOISE	DISTANZSTÜCK	SPACER			83556
19	63000300	1	ANELLO ELASTICO	BAGUE	SPANNRING	SNAP-RING	Ø 72 I UNI 7437		83556
20	63000600	1	ANELLO ELASTICO	BAGUE	SPANNRING	SNAP-RING	Ø 35 E UNI 7435		83556
21	66014800	1	ANELLO TENUTA	JOINT D'ETANCHEITE	DICHTUNGSRING	JUNT RING	35 x 72 x 10		83556
22	63000300	1	ANELLO ELASTICO	BAGUE	SPANNRING	SNAP-RING	Ø 72 I UNI 7437		83556
23	62007900	1	DADO	ECROU	MUTTER	NUT	M 24 x 2 INTAGLI UNI 5594		83556
24	64003000	1	COPIGLIA	COUPILLE	SPLINT	COTTER PIN	5 x 50 UNI 1336		83556
25	46036500	1	MOLTIPLICATORE COMPL.	MULTIPLICATEUR COMPL.	KOMPL. GETRIEBE	COMPLETE GEAR BOX			83556

DA MATR. 83557 - A PARTIR DE NR. SERIE 83557 - VOM SERIENN.R. 83557 - FROM SERIAL NR. 83557

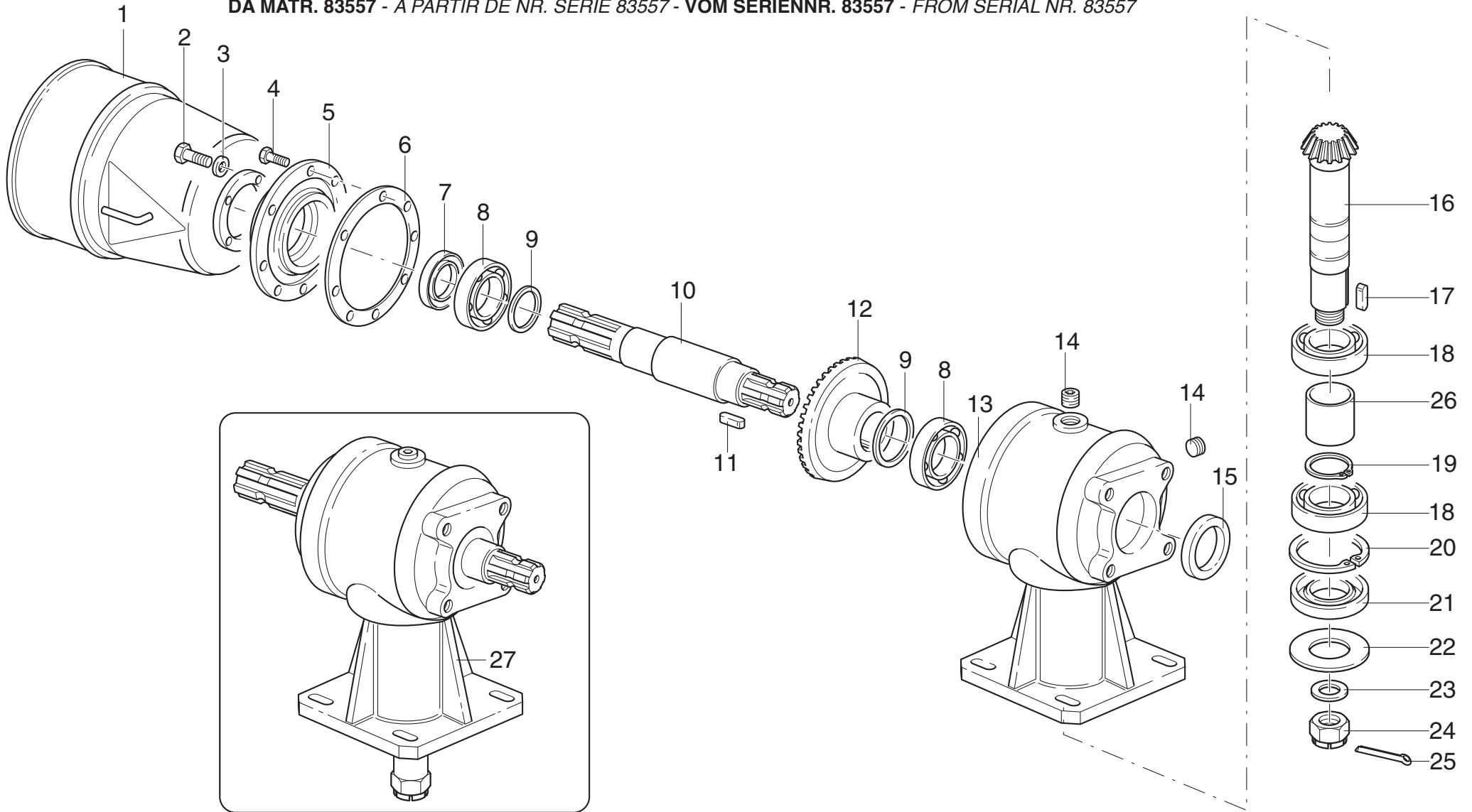

MURATORI MR

TAV. 5.3

POS.	N° CODICE	Q.	DESCRIZIONE	DESIGNATION	BENENNUNG	DESCRIPTION	DESIGNAZIONE	Da matr. De nr. serie Vom Seriennr. From serial nr.	Fino matr. Jusqu'au nr. serie Bis Seriennr. Up to serial nr.
1	68061501	1	PROTEZIONE	PROTECTION	SCHUTZ	GUARD		83557	
2	60022800	4	VITE	VIS	SCHRAUBE	SCREW	TE 8 x 20 UNI 5739 8.8 ZNT	83557	
3	61006200	4	RONDELLA	RONDELLE	SCHEIBE	WASHER	PIANA Øi 9 Øe 24 Sp.1,5	83557	
4	60039800	8	VITE	VIS	SCHRAUBE	SCREW	TE 6 x 18 UNI 5739	83557	
5	10043300	1	FLANGIA	BRIDE	FLANSCH	FLANGE		83557	
6	80015700	1	GUARNIZIONE	GARNITURE	DICHTUNG	SEAL		83557	
7	66005400	1	ANELLO TENUTA	JOINT D'ETANCHEITE	DICHTUNGSRING	JUNT RING	40 x 56 x 8	83557	
8	67016700	2	CUSCINETTO	ROULEMENT	LAGER	BEARING	6008	83557	
9	68093800		SPESSORE	EPAISSEUR	BEILAGERING	SPACER	40 x 46 x 0,1	83557	
10	31085000	1	ALBERO	ARBRE	WELLE	SHAFT		83557	
11	65002500	1	LINGUETTA	CLAVETTE	FEDER	KEY	12 x 8 x 30	83557	
12	10044000	1	CORONA	COURONNE	KRANZ	CROWN		83557	
13	01018100	1	SCATOLA	CARTER	GEHÄUSE	GEARBOX		83557	
14	68093900	2	TAPPO	BOUCHON	STOPFEN	PLUG		83557	
15	66006200	1	ANELLO TENUTA	JOINT D'ETANCHEITE	DICHTUNGSRING	JUNT RING	42 x 60 x 10	83557	
16	10044100	1	ALBERO	ARBRE	WELLE	SHAFT		83557	
17	65000100	1	LINGUETTA	CLAVETTE	FEDER	KEY	10 x 8 x 40	83557	
18	67003700	2	CUSCINETTO	ROULEMENT	LAGER	BEARING	6207	83557	
19	63006900	1	ANELLO ELASTICO	BAGUE	SPANNRING	SNAP-RING	Ø 35 E UNI 7436	83557	
20	63000300	1	ANELLO ELASTICO	BAGUE	SPANNRING	SNAP-RING	Ø 72 I UNI 7437	83557	
21	66001500	1	ANELLO TENUTA	JOINT D'ETANCHEITE	DICHTUNGSRING	JUNT RING	35 x 72 x 10	83557	
22	32182200	1	DISTANZIALE	ENTRETOISE	DISTANZSTÜCK	SPACER		83557	
23	61000700	1	RONDELLA	RONDELLE	SCHEIBE	WASHER	PIANA Ø25 UNI 6592	83557	
24	62015100	1	DADO	ECROU	MUTTER	NUT	M 24 x 2 INTAGLI UNI 5594	83557	
25	64000100	1	COPIGLIA	COUPILLE	SPLINT	COTTER PIN	5 x 40 UNI 1336	83557	
26	32182200	1	DISTANZIALE	ENTRETOISE	DISTANZSTÜCK	SPACER		83557	

DA MATR. 83557 - A PARTIR DE NR. SERIE 83557 - VOM SERIENN.R. 83557 - FROM SERIAL NR. 83557

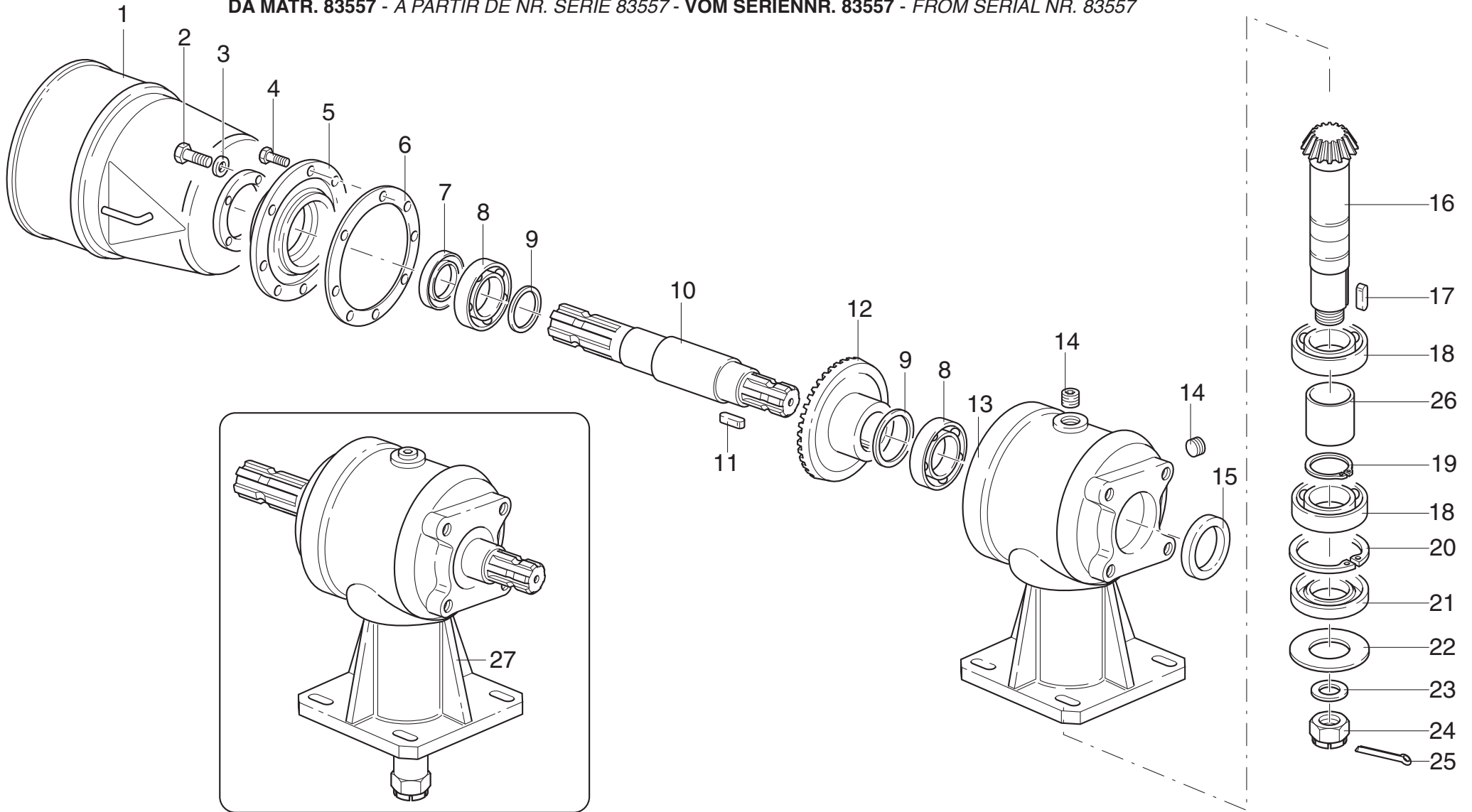

FINO MATR. 85719 - JUSQU'AU NR. SERIE 85719 - BIS SERIENNR. 85719 - UP TO SERIAL NR. 85719

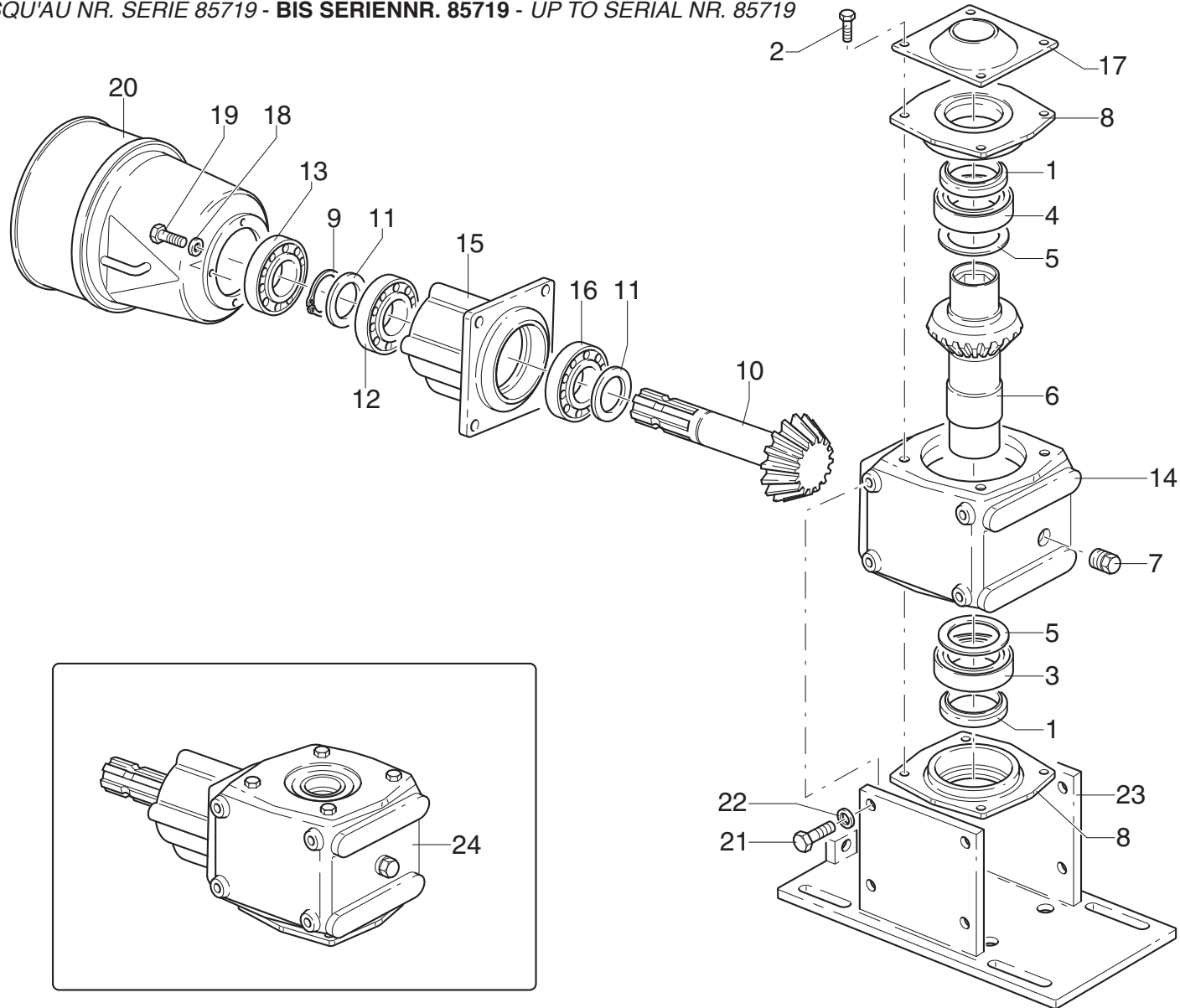

MURATORI MR

TAV. 5.4

POS.	N° CODICE	Q.	DESCRIZIONE	DESIGNATION	BENENNUNG	DESCRIPTION	DESIGNAZIONE	Da matr. De nr. serie Vom Seriennr. From serial nr.	Fino matr. Jusqu'au nr. serie Bis Seriennr. Up to serial nr.
1	66003900	2	ANELLO TENUTA	JOINT D'ETANCHEITE	DICHTUNGSRING	JUNT RING	50 x 65 x 8		85719
2	60020400	8	VITE	VIS	SCHRAUBE	SCREW	TE 12 x 25 UNI 5739 8.8 ZNT		85719
3	67006600	1	CUSCINETTO	ROULEMENT	LAGER	BEARING	6010		85719
4	67019000	1	CUSCINETTO	ROULEMENT	LAGER	BEARING	6010 2RS		85719
5	68009700		SPESSORE	EPAISSEUR	BEILAGERING	SPACER	50 x 70		85719
6	10030700	1	CORONA	COURONNE	KRANZ	CROWN			85719
7	68008700	1	TAPPO	BOUCHON	STOPFEN	PLUG	3/8"		85719
8	01008500	2	COPERCHIO	COUVERCLE	DECKEL	COVER			85719
9	63000600	1	ANELLO ELASTICO	BAGUE	SPANNRING	SNAP-RING	Øe 35UNI 7435		85719
10	10012700	1	ALBERO	ARBRE	WELLE	SHAFT	Z 13		85719
11	68025800		SPESSORE	EPAISSEUR	BEILAGERING	SPACER	43 x 35		85719
12	67003700	1	CUSCINETTO	ROULEMENT	LAGER	BEARING	6207		85719
13	66001500	1	ANELLO TENUTA	JOINT D'ETANCHEITE	DICHTUNGSRING	JUNT RING	35 x 72 x 10		85719
14	01008400	1	SCATOLA	CARTER	GEHÄUSE	GEARBOX			85719
15	01008600	1	PROLUNGA	RALLONGE	VERLÄNGERUNGSROHR	EXTENSION			85719
16	67000300	1	CUSCINETTO	ROULEMENT	LAGER	BEARING	30207		85719
17	39273100	1	PROTEZIONE	PROTECTION	SCHUTZ	GUARD			85719
18	61000500	4	RONDELLA	RONDELLE	SCHEIBE	WASHER	DENT. Ø12 UNI 3704		85719
19	60020400	4	VITE	VIS	SCHRAUBE	SCREW	TE 12 x 25 UNI 5739 8.8 ZNT		85719
20	68061501	1	PROTEZIONE	PROTECTION	SCHUTZ	GUARD			85719
21	60020400	8	VITE	VIS	SCHRAUBE	SCREW	TE 12 x 25 UNI 5739 8.8 ZNT		85719
22	61001400	8	RONDELLA	RONDELLE	SCHEIBE	WASHER	GROWER Ø 12 UNI 1751		85719
23	40247400	1	CONTROPIASTRA	CONTRE-PLAQUE	GEGENPLATTE	COUNTER PLATE			85719
24	46009600	1	RIDUTTORE	BOITIER	GETRIEBE	GEARBOX ASSEMBLY			85719

DA MATR. 85720 - A PARTIR DE NR. SERIE 85720 - VOM SERIENNR. 85720 - FROM SERIAL NR. 85720

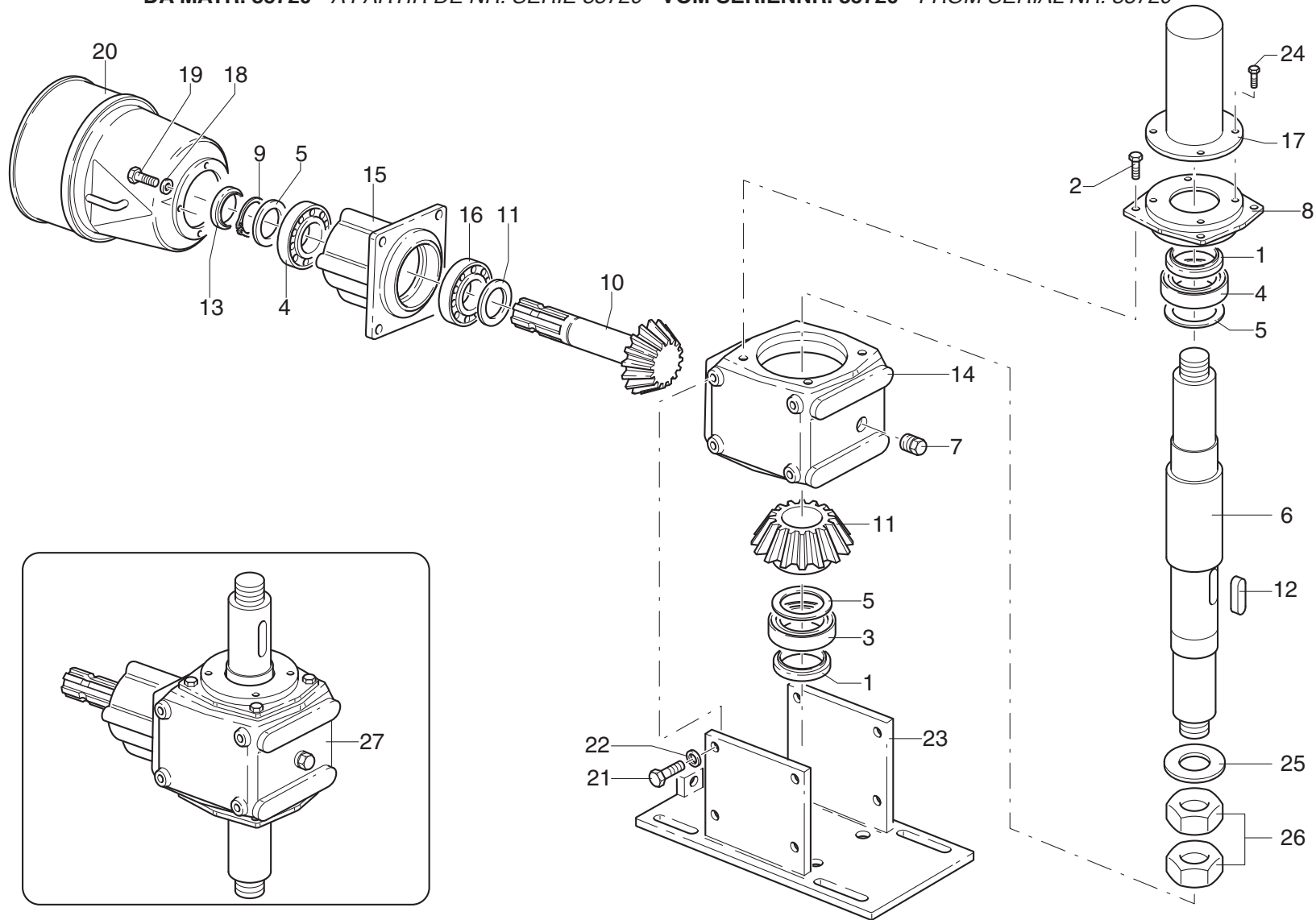

MURATORI MR

TAV. 5.5

POS.	N° CODICE	Q.	DESCRIZIONE	DESIGNATION	BENENNUNG	DESCRIPTION	DESIGNAZIONE	Da matr. De nr. serie Vom Seriennr. From serial nr.	Fino matr. Jusqu'au nr. serie Bis Seriennr. Up to serial nr.
1	66001600	2	ANELLO TENUTA	JOINT D'ETANCHEITE	DICHTUNGSRING	JUNT RING	35 x 52 x 7	85720	
2	60020400	8	VITE	VIS	SCHRAUBE	SCREW	TE 12 x 25 UNI 5739 8.8 ZNT	85720	
3	67006700	1	CUSCINETTO	ROULEMENT	LAGER	BEARING	6207 2RS	85720	
4	67003700	2	CUSCINETTO	ROULEMENT	LAGER	BEARING	6207	85720	
5	68025800		SPESSORE	EPAISSEUR	BEILAGERING	SPACER	43 x 35	85720	
6	31088000	1	ALBERO	ARBRE	WELLE	SHAFT		85720	
7	68008700	1	TAPPO	BOUCHON	STOPFEN	PLUG	3/8"	85720	
8	01018700	1	COPERCHIO	COUVERCLE	DECKEL	COVER		85720	
9	63000600	1	ANELLO ELASTICO	BAGUE	SPANNRING	SNAP-RING	Øe 35UNI 7435	85720	
10	10012700	1	ALBERO	ARBRE	WELLE	SHAFT		85720	
11	10046100	1	CORONA	COURONNE	KRANZ	CROWN	Z 19	85720	
12	65000600	1	LINGUETTA	CLAVETTE	FEDER	KEY	10 x 8 x 30 UNI 6604	85720	
13	66001500	1	ANELLO TENUTA	JOINT D'ETANCHEITE	DICHTUNGSRING	JUNT RING	35 x 72 x 10	85720	
14	01018600	1	SCATOLA	CARTER	GEHÄUSE	GEARBOX		85720	
15	01008600	1	PROLUNGA	RALLONGE	VERLÄNGERUNGSROHR	EXTENSION		85720	
16	67000300	1	CUSCINETTO	ROULEMENT	LAGER	BEARING	30207	85720	
17	68092200	1	PROTEZIONE	PROTECTION	SCHUTZ	GUARD		85720	
18	61000500	4	RONDELLA	RONDELLE	SCHEIBE	WASHER	DENT. Ø12 UNI 3704	85720	
19	60020400	4	VITE	VIS	SCHRAUBE	SCREW	TE 12 x 25 UNI 5739 8.8 ZNT	85720	
20	68061501	1	PROTEZIONE	PROTECTION	SCHUTZ	GUARD		85720	
21	60020400	8	VITE	VIS	SCHRAUBE	SCREW	TE 12 x 25 UNI 5739 8.8 ZNT	85720	
22	61001400	8	RONDELLA	RONDELLE	SCHEIBE	WASHER	GROWER Ø 12 UNI 1751	85720	
23	40247400	1	SUPPORTO	SUPPORT	HALTERUNG	SUPPORT	150-180	85720	
24	60015100	4	VITE	VIS	SCHRAUBE	SCREW	TE 8 x 16 UNI 5739	85720	
25	61009100	1	RONDELLA	RONDELLE	SCHEIBE	WASHER	PIANA Ø 27 UNI 6592	85720	
26	62001200	2	DADO	ECROU	MUTTER	NUT	M 25 x 1.5 GUK	85720	

DA MATR. 85720 - A PARTIR DE NR. SERIE 85720 - VOM SERIENNR. 85720 - FROM SERIAL NR. 85720

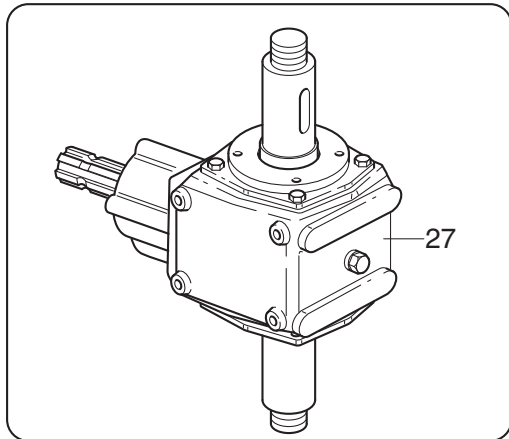
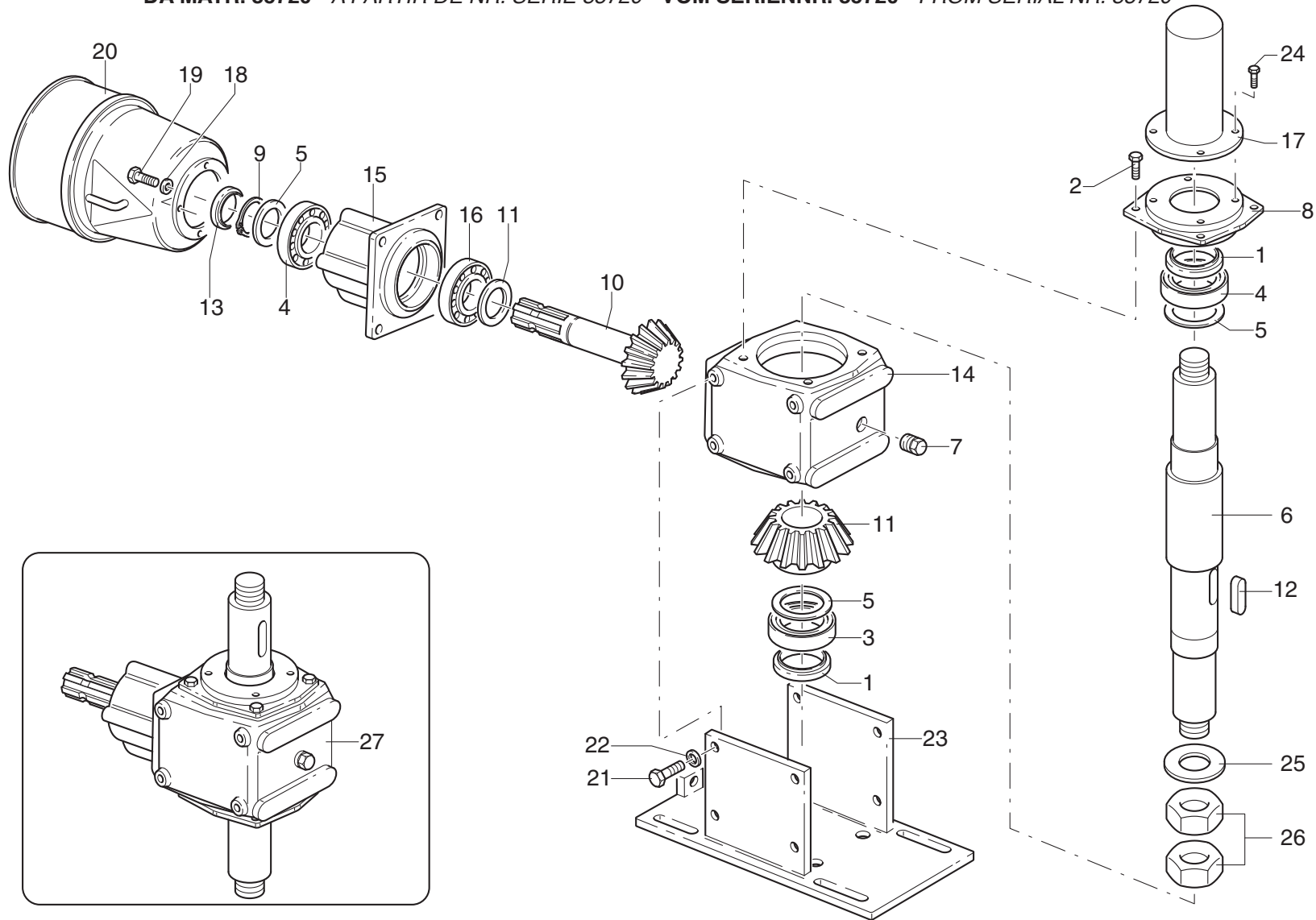

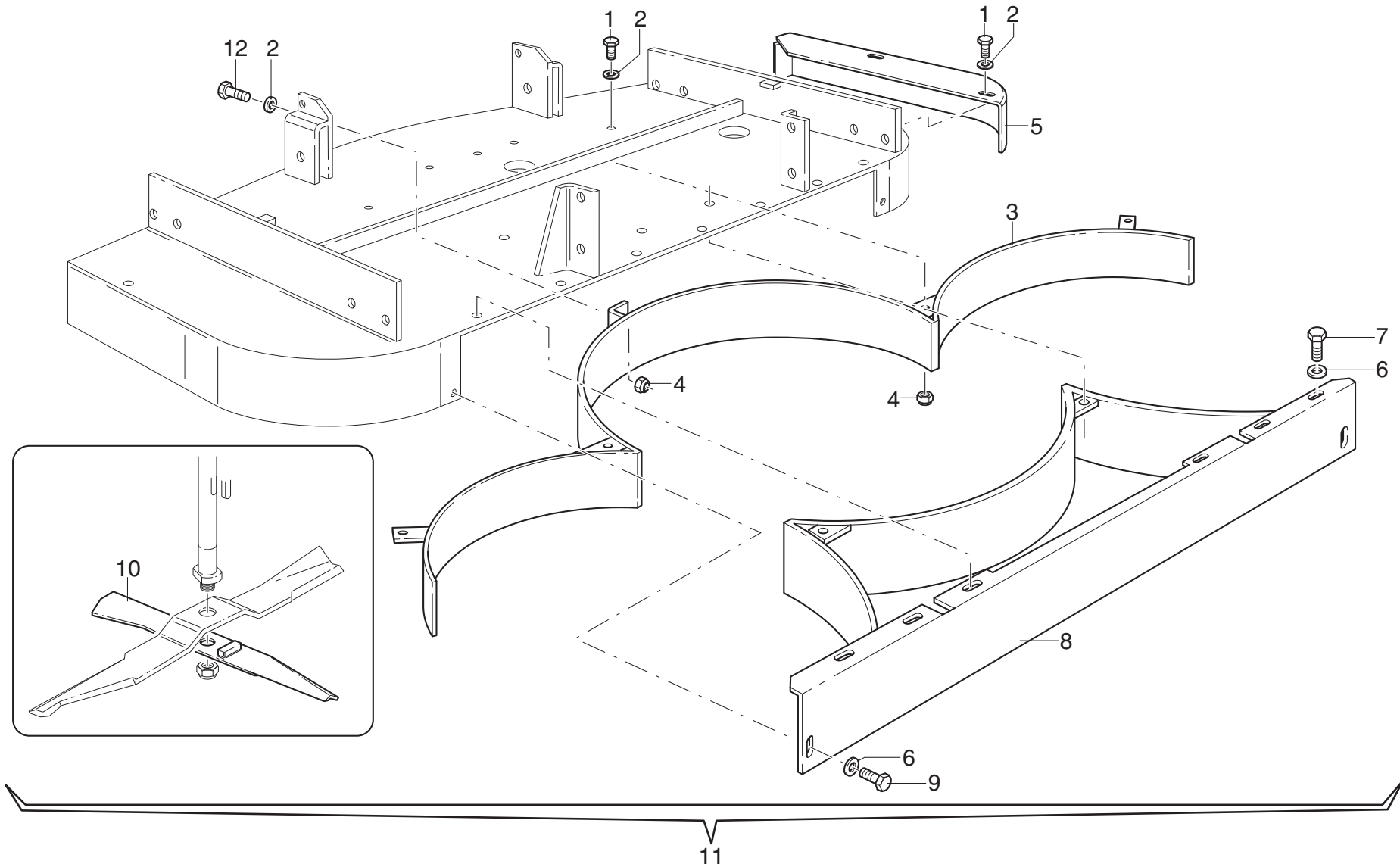

MURATORI MR

TAV. 6.0

POS.	N° CODICE	Q.	DESCRIZIONE	DESIGNATION	BENENNUNG	DESCRIPTION	DESIGNAZIONE	Da matr. De nr. serie Vom Seriennr. From serial nr.	Fino matr. Jusqu'au nr. serie Bis Seriennr. Up to serial nr.
1	60017900		VITE	VIS	SCHRAUBE	SCREW	TE 10 x 25 UNI 5739 8.8 ZNT		
2	61004900		RONDELLA	RONDELLE	SCHEIBE	WASHER	PIANA Ø 10 UNI 6592		
3	40233500	1	DEFLETTORE	DEFLECTEUR	LEITBLECH	DEFLECTOR	120		
3	49298000	1	DEFLETTORE	DEFLECTEUR	LEITBLECH	DEFLECTOR	135		
3	40233600	1	DEFLETTORE	DEFLECTEUR	LEITBLECH	DEFLECTOR	150		
3	40233700	1	DEFLETTORE	DEFLECTEUR	LEITBLECH	DEFLECTOR	180		
3	40298100	1	DEFLETTORE	DEFLECTEUR	LEITBLECH	DEFLECTOR	210		
4	62010400	3	DADO	ECROU	MUTTER	NUT	M 10 x 1.5 AUTOBLOCC.		
5	40233200	1	CHIUSURA	FERMETURE	VERSCHLUSS	GRIPPING	120		
5	40297800	1	CHIUSURA	FERMETURE	VERSCHLUSS	GRIPPING	135		
5	40233300	1	CHIUSURA	FERMETURE	VERSCHLUSS	GRIPPING	150		
5	40233400	1	CHIUSURA	FERMETURE	VERSCHLUSS	GRIPPING	180		
5	40297900	1	CHIUSURA	FERMETURE	VERSCHLUSS	GRIPPING	210		
6	61004900	8	RONDELLA	RONDELLE	SCHEIBE	WASHER	PIANA Ø 10 UNI 6592		
7	60021600	6	VITE	VIS	SCHRAUBE	SCREW	TE 10 x 20 UNI 5739 8.8 ZNT		
8	40232900	1	CHIUSURA	FERMETURE	VERSCHLUSS	GRIPPING	120		
8	40297600	1	CHIUSURA	FERMETURE	VERSCHLUSS	GRIPPING	135		
8	40233000	1	CHIUSURA	FERMETURE	VERSCHLUSS	GRIPPING	150		
8	40233100	1	CHIUSURA	FERMETURE	VERSCHLUSS	GRIPPING	180		
8	40297700	1	CHIUSURA	FERMETURE	VERSCHLUSS	GRIPPING	210		
9	60038700	2	VITE	VIS	SCHRAUBE	SCREW	TBCE 10 x 25 UNI 7380		
10	12.0182.00	3	LAMA "MULCHING"	LAME DE COUPE "MULCHING"	"MULCHING" SCHNEIDKANTE	"MULCHING" BLADE	120		
10	12.0214.00	3	LAMA "MULCHING"	LAME DE COUPE "MULCHING"	"MULCHING" SCHNEIDKANTE	"MULCHING" BLADE	135		
10	12.0183.00	3	LAMA "MULCHING"	LAME DE COUPE "MULCHING"	"MULCHING" SCHNEIDKANTE	"MULCHING" BLADE	150		
10	12.0184.00	3	LAMA "MULCHING"	LAME DE COUPE "MULCHING"	"MULCHING" SCHNEIDKANTE	"MULCHING" BLADE	180		
10	12.0215.00	3	LAMA "MULCHING"	LAME DE COUPE "MULCHING"	"MULCHING" SCHNEIDKANTE	"MULCHING" BLADE	210		

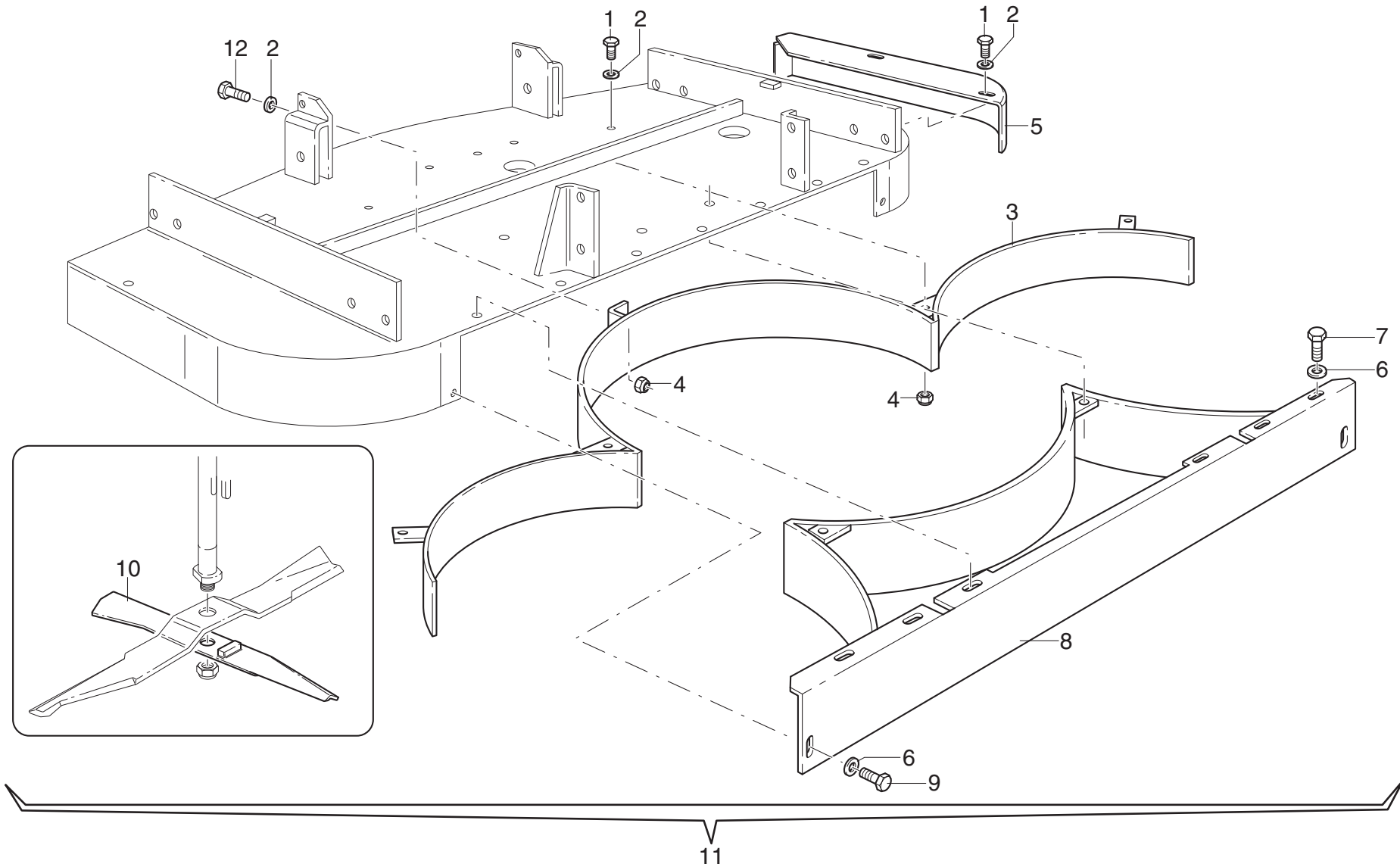

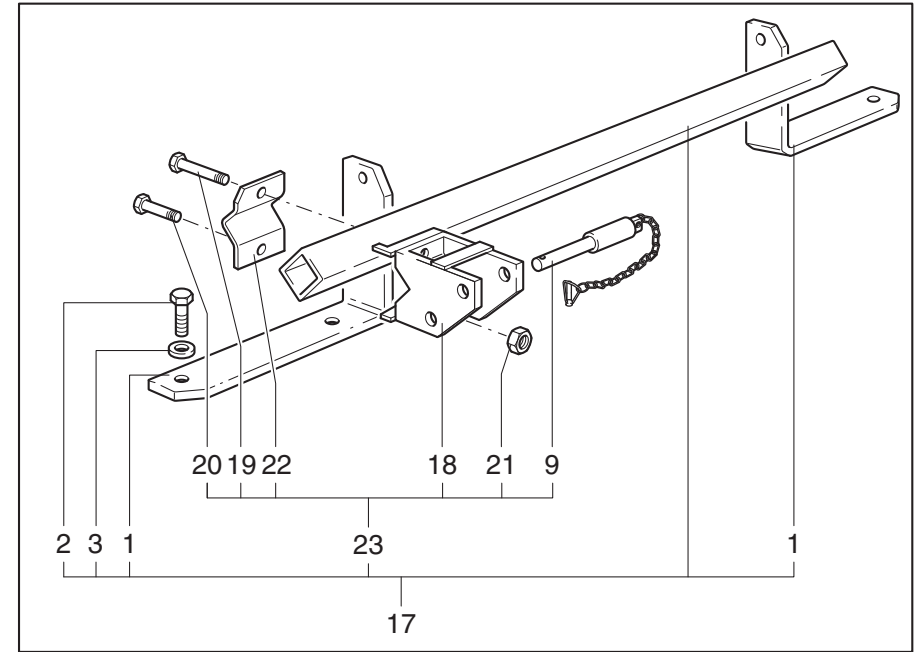
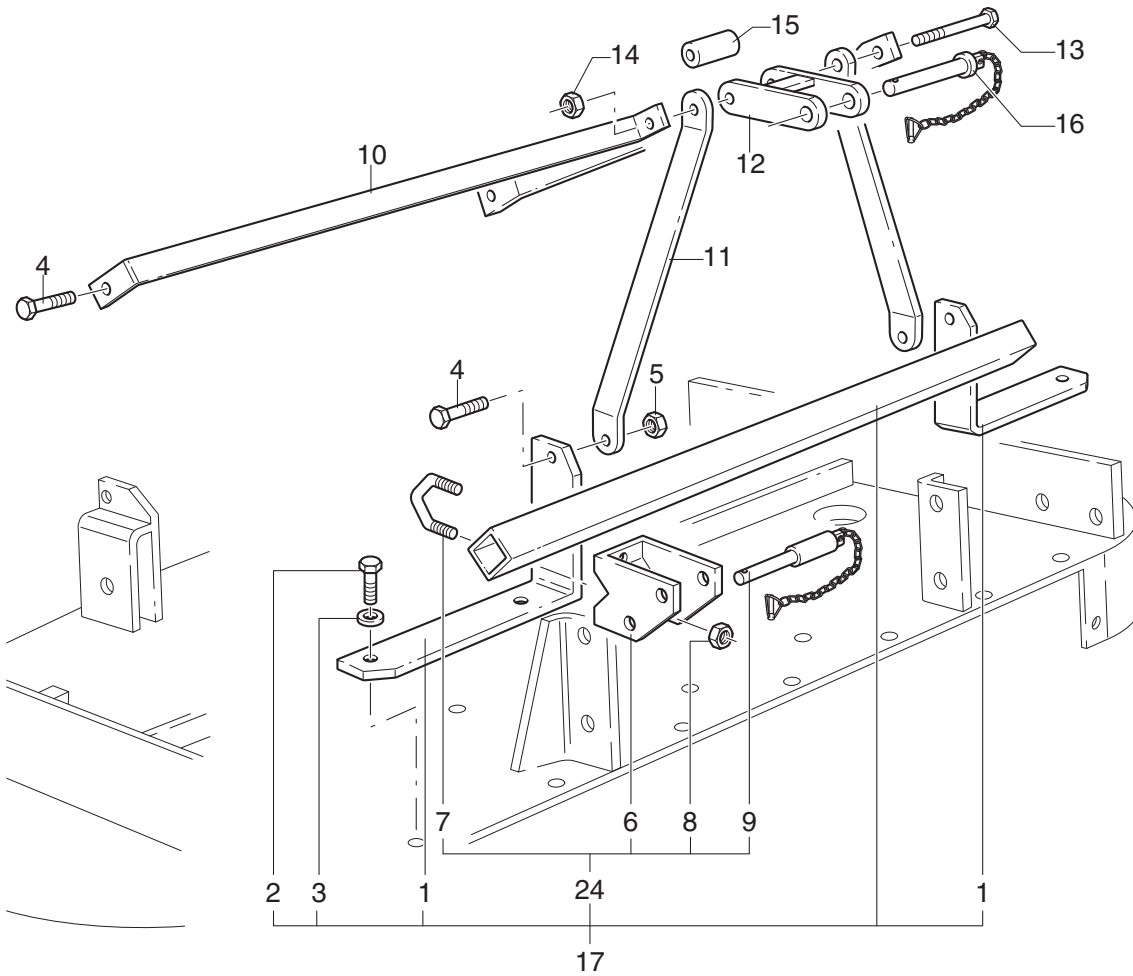

MURATORI MR

TAV. 7.0

POS.	N° CODICE	Q.	DESCRIZIONE	DESIGNATION	BENENNUNG	DESCRIPTION	DESIGNAZIONE	Da matr. De nr. serie Vom Seriennr. From serial nr.	Fino matr. Jusqu'au nr. serie Bis Seriennr. Up to serial nr.
1	40234400	1	STAFFA	BRIDE	BÜGEL	BRACKET	120-135		
1	40234500	1	STAFFA	BRIDE	BÜGEL	BRACKET	150-180-210		
2	60023500		VITE	VIS	SCHRAUBE	SCREW	TE 10 x 35 UNI 5739 8.8 ZNT		
3	61004900		RONDELLA	RONDELLE	SCHEIBE	WASHER	PIANA Ø 10 UNI 6592		
4	60028200	4	VITE	VIS	SCHRAUBE	SCREW	TE 12 x 40 UNI 5739 8.8 ZNT		
5	62010600	4	DADO	ECROU	MUTTER	NUT	M 12 x 1.75 AUTOBLOCC.		
6	40262100	2	STAFFA	BRIDE	BÜGEL	BRACKET			115986
7	38022301	2	CAVALLOTTO	ARRETOIR	KLEMMSTÜCK	UBOLT			115986
8	62010600	4	DADO	ECROU	MUTTER	NUT	M 12 x 1.75 AUTOBLOCC.		115986
9	68062300	2	PERNO	PIVOT	BOLZEN	PIN			
10	30182800	2	TIRANTE	TIRANT	STANGE	TIEROD	120		
10	30205300	2	TIRANTE	TIRANT	STANGE	TIEROD	135		
10	30182900	2	TIRANTE	TIRANT	STANGE	TIEROD	150		
10	30183000	2	TIRANTE	TIRANT	STANGE	TIEROD	180		
10	30205400	2	TIRANTE	TIRANT	STANGE	TIEROD	210		
11	30178900	2	TIRANTE	TIRANT	STANGE	TIEROD			
12	40237800	1	ATTACCO	ATTACHE	ANSCHLUSS	ATTACHMENT			
13	60011900	1	VITE	VIS	SCHRAUBE	SCREW	TE 12 x 120 UNI 5737		
14	62010600	1	DADO	ECROU	MUTTER	NUT	M 12 x 1.75 AUTOBLOCC.		
15	32021400	1	DISTANZIALE	ENTRETOISE	DISTANZSTÜCK	SPACER			
16	38024100	2	PERNO	PIVOT	BOLZEN	PIN			
17	45113300		KIT ATTACCO FRONTALE	KIT ATTELAGE FRONTAL	FRONTANBAUSATZ	FRONT LINKAGE KIT	120-135		
17	45113400		KIT ATTACCO FRONTALE	KIT ATTELAGE FRONTAL	FRONTANBAUSATZ	FRONT LINKAGE KIT	150-180-210		
18	40262101	2	STAFFA	BRIDE	BÜGEL	BRACKET		115987	
19	60010100	2	VITE	VIS	SCHRAUBE	SCREW	TE 12x65 UNI 5737	115987	
20	60045400	2	VITE	VIS	SCHRAUBE	SCREW	TE 12x55 UNI 5737	115987	

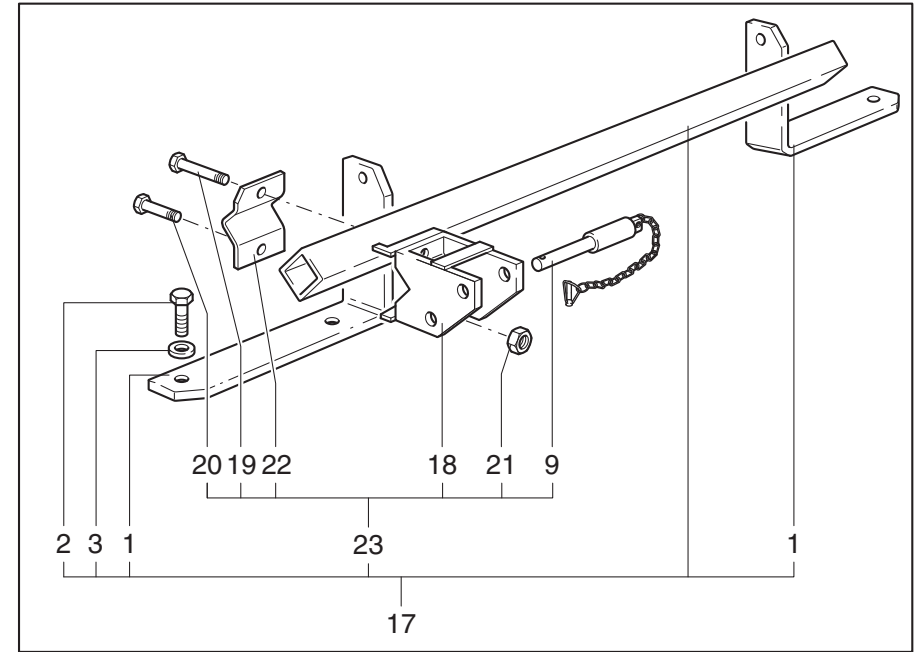
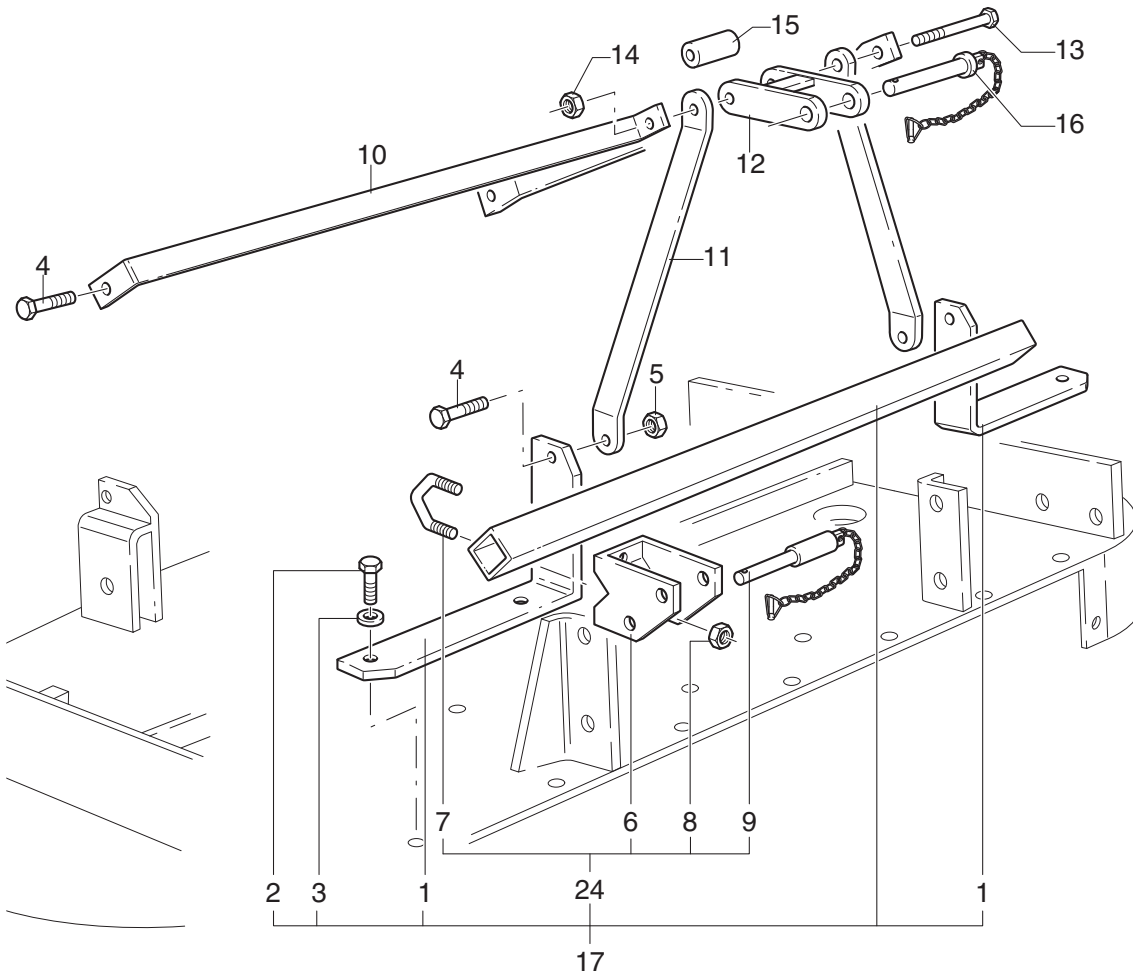

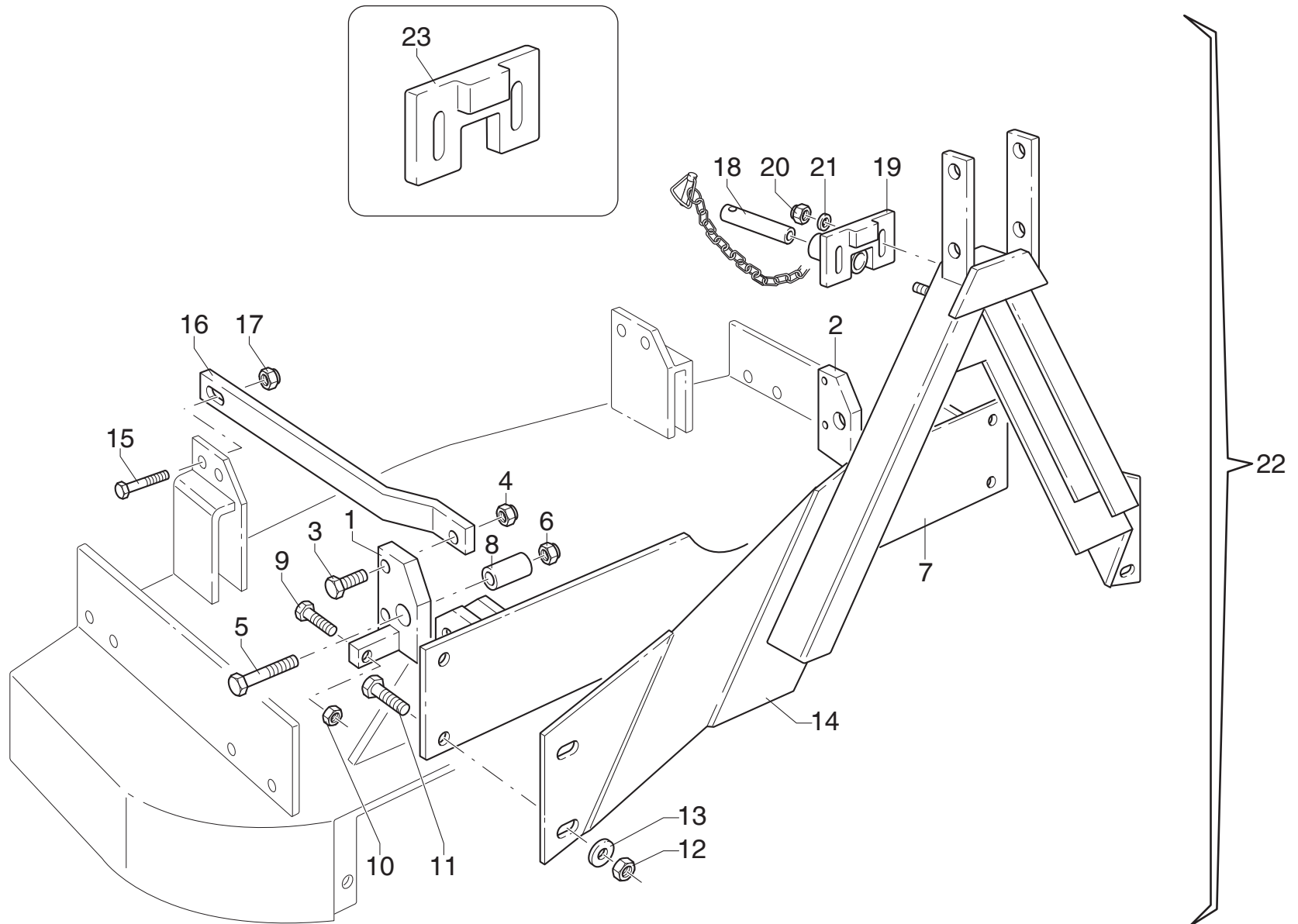

MURATORI MR

TAV. 8.0

POS.	N° CODICE	Q.	DESCRIZIONE	DESIGNATION	BENENNUNG	DESCRIPTION	DESIGNAZIONE	Da matr. De nr. serie Vom Seriennr. From serial nr.	Fino matr. Jusqu'au nr. serie Bis Seriennr. Up to serial nr.
1	40238200	1	STAFFA DX	BRIDE (D)	BÜGEL (RECHTS)	BRACKET (RH)			
2	40238100	1	STAFFA SX	BRIDE (G)	BÜGEL (LINKS)	BRACKET (LH)			
3	60028100	4	VITE	VIS	SCHRAUBE	SCREW	TE 12 x 55 UNI 5739		
4	62010600	4	DADO	ECROU	MUTTER	NUT	M 12 x 1.75 AUTOBLOCC.		
5	60014300	2	VITE	VIS	SCHRAUBE	SCREW	TE 16 x 65 UNI 5737		
6	62008900	2	DADO	ECROU	MUTTER	NUT	M 16 x 2 UNI 5588		
7	40238300	1	STAFFA	BRIDE	BÜGEL	BRACKET			
8	32167400	2	DISTANZIALE	ENTRETOISE	DISTANZSTÜCK	SPACER			
9	60042400	2	VITE	VIS	SCHRAUBE	SCREW	TE 16 x 45 UNI 5739		
10	62011000	2	DADO	ECROU	MUTTER	NUT	M 16 x 2 AUTOBLOCC.		
11	60023000	4	VITE	VIS	SCHRAUBE	SCREW	TE 12 x 30 UNI 5739 8.8 ZNT		
12	62010600	4	DADO	ECROU	MUTTER	NUT	M 12 x 1.75 AUTOBLOCC.		
13	61005000	4	RONDELLA	RONDELLE	SCHEIBE	WASHER	Ø 12 PIANA UNI 6592		
14	40308900	1	ATTACCO	ATTACHE	ANSCHLUSS	ATTACHMENT			
15	60021200	2	VITE	VIS	SCHRAUBE	SCREW	TE 12 x 35 UNI 5739 8.8 ZNT		
16	30191300	2	TIRANTE	TIRANT	STANGE	TIEROD	120		
16	30205500	2	TIRANTE	TIRANT	STANGE	TIEROD	135		
16	30191400	2	TIRANTE	TIRANT	STANGE	TIEROD	150		
16	30191500	2	TIRANTE	TIRANT	STANGE	TIEROD	180		
16	30205600	2	TIRANTE	TIRANT	STANGE	TIEROD	210		
17	62010600	2	DADO	ECROU	MUTTER	NUT	M 12 x 1.75 AUTOBLOCC.		
18	68087100	1	PERNO	PIVOT	BOLZEN	PIN			
19	40246700	1	BLOCCAGGIO	BLOCAGE	BEFESTIGUNG	LOCK			
20	62010200	2	DADO	ECROU	MUTTER	NUT	M 8 x 1.25 AUTOBLOCC.		
21	61004700	2	RONDELLA	RONDELLE	SCHEIBE	WASHER	Ø 8 PIANA UNI 6592		
22	45119200		KIT ATTACCO FRONTALE	KIT ATTELAGE FRONTAL	FRONTANBAUSATZ	FRONT LINKAGE KIT	120		

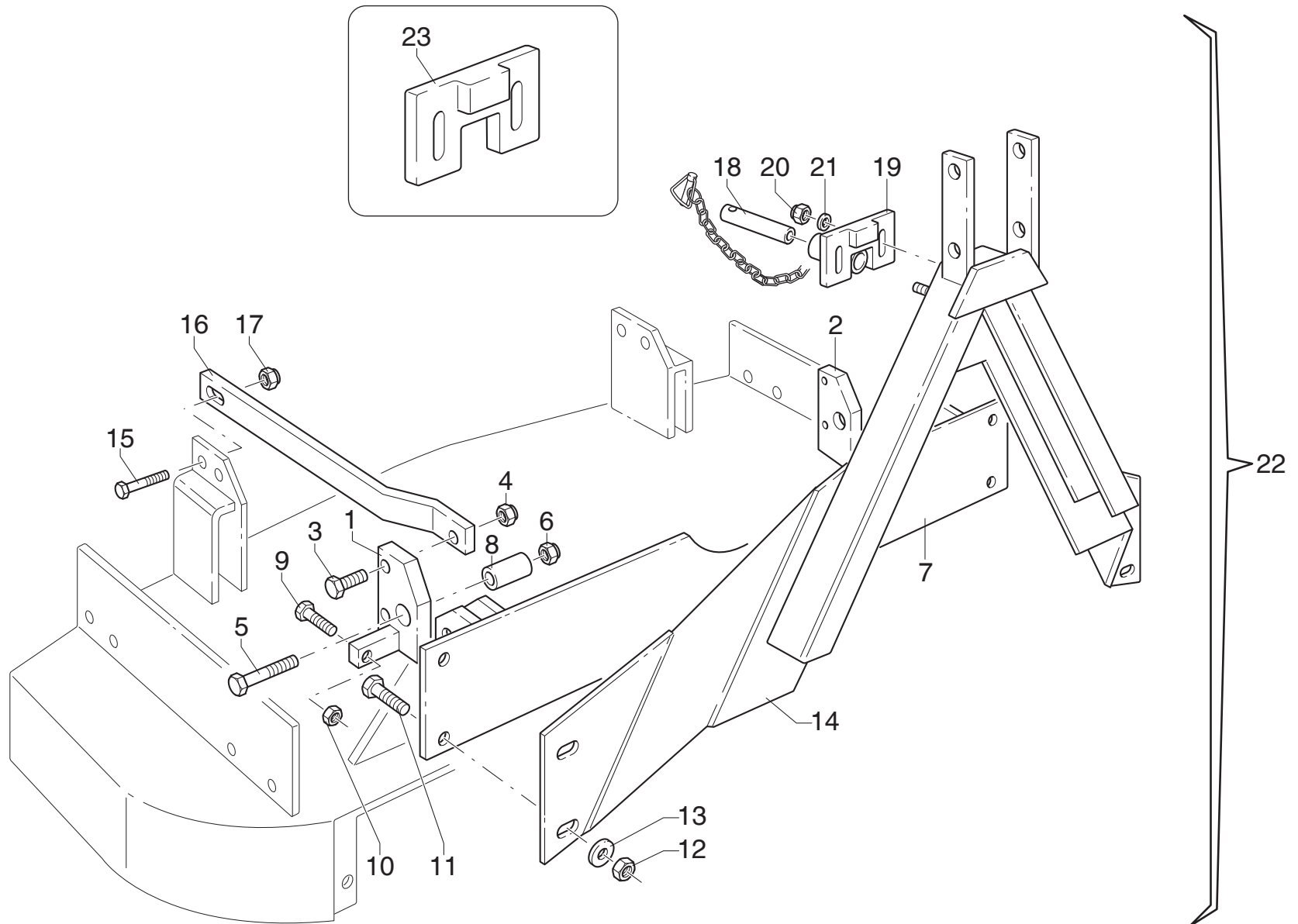

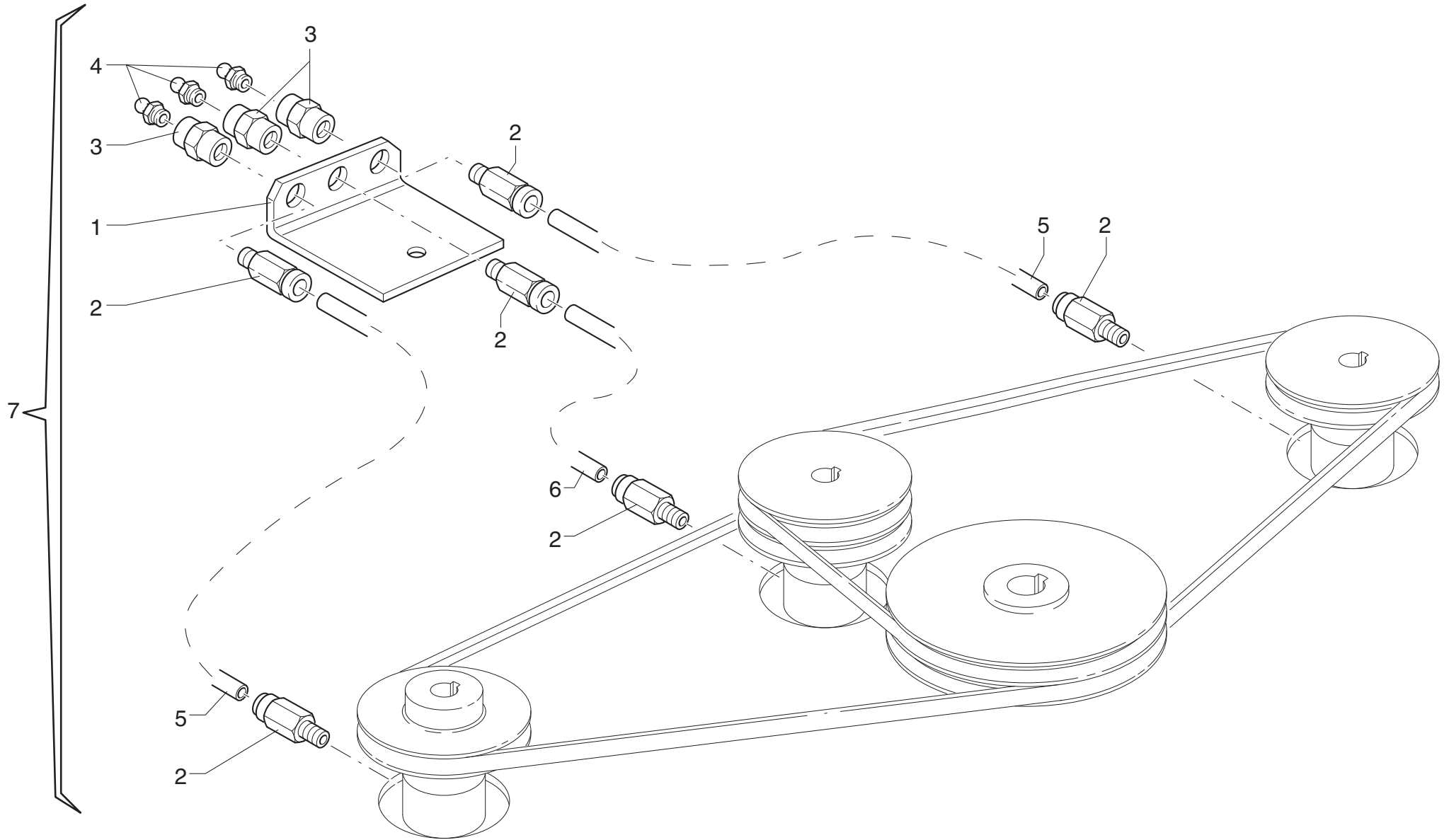

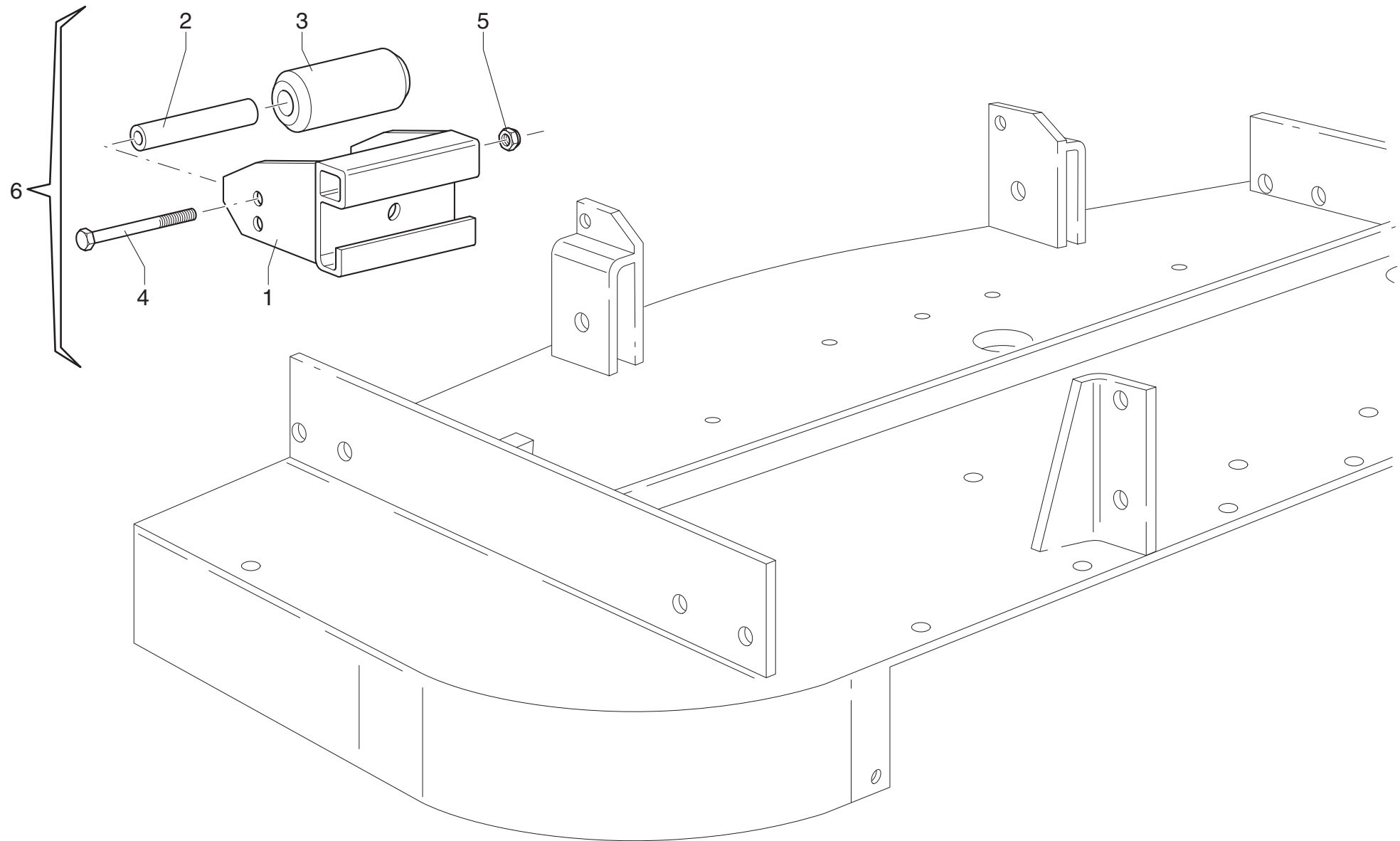

FINO MATR. 124405 - JUSQU'AU NR. SERIE 124405 - BIS SERIENNR. 124405 - UP TO SERIAL NR. 124405

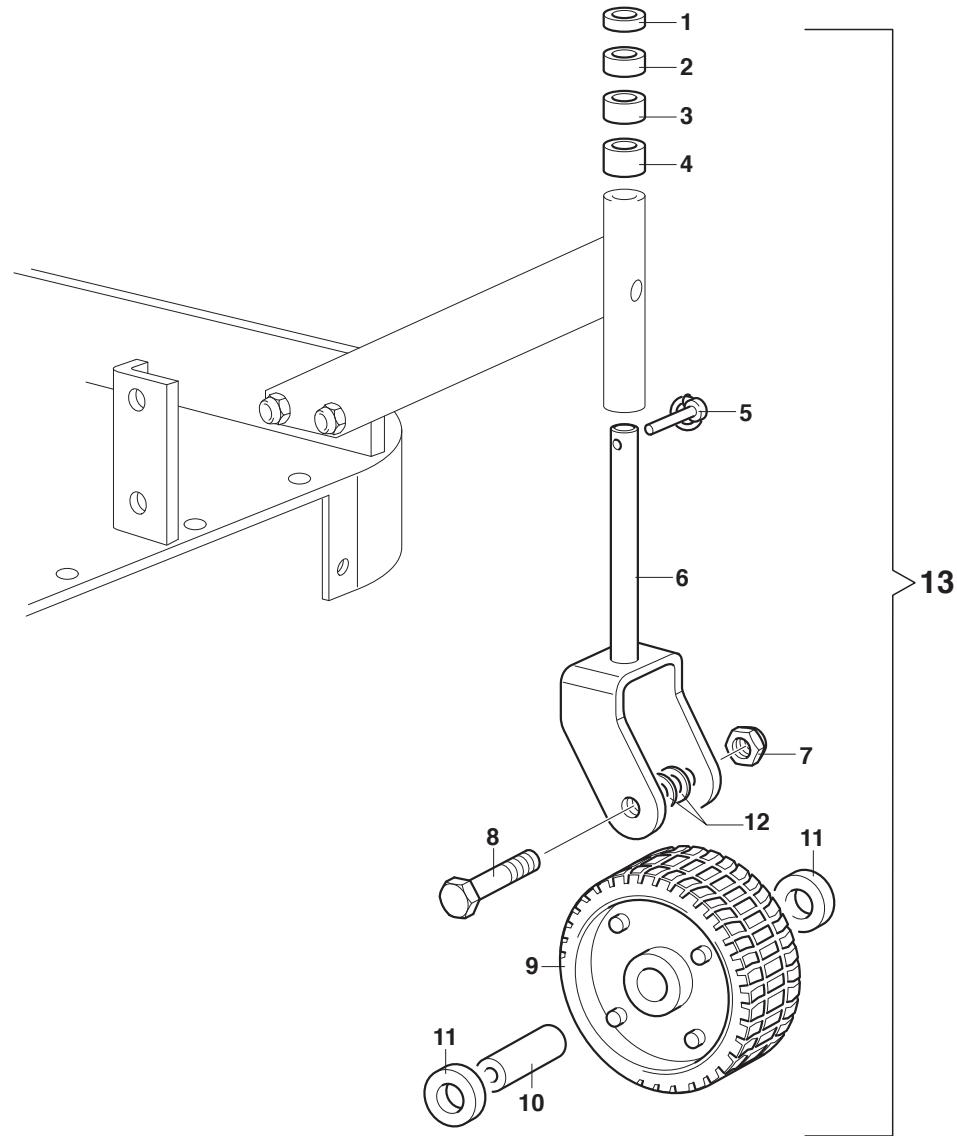

DA MATR. 124406 - A PARTIR DE NR. SERIE 124406 - VOM SERIENNR. 124406 - FROM SERIAL NR. 124406

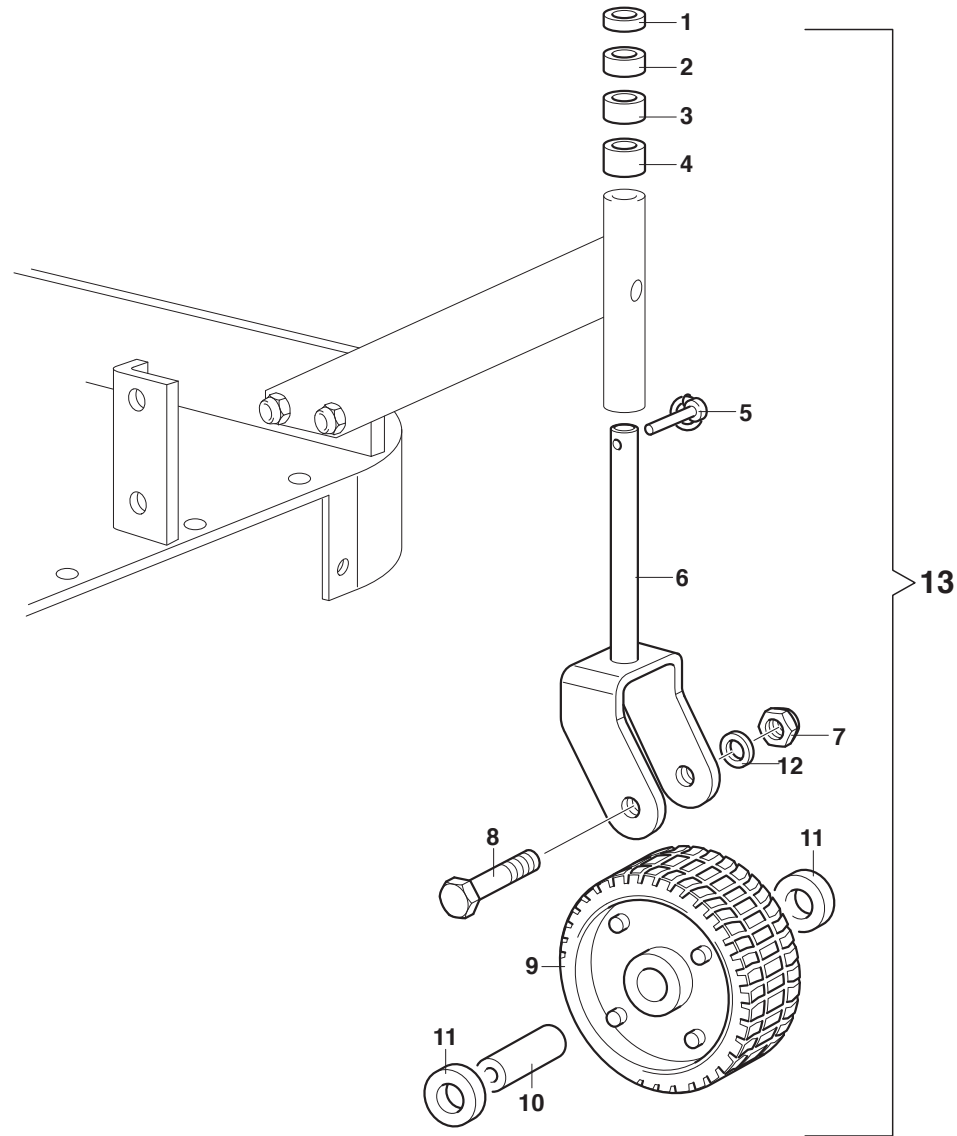

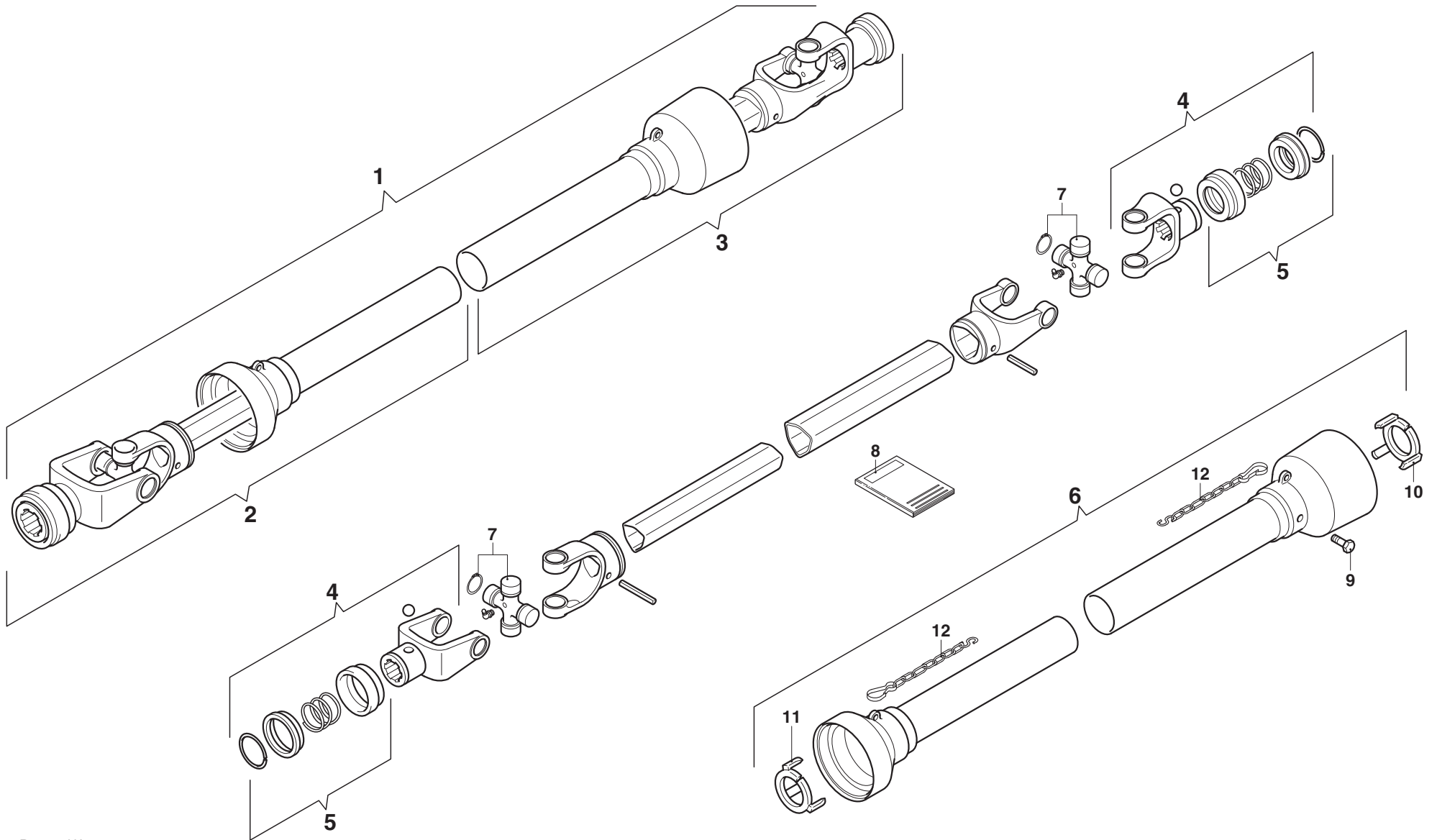

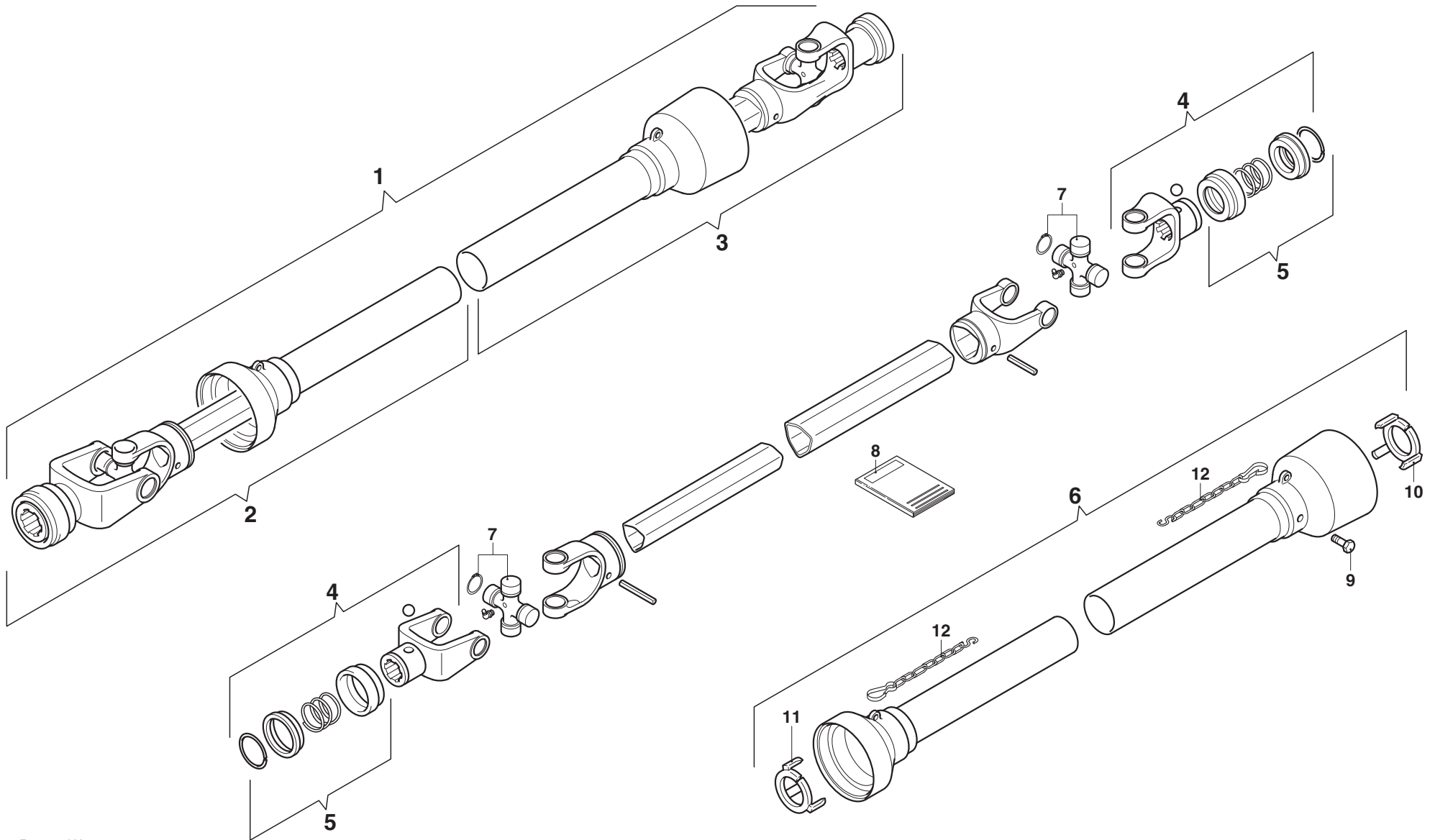

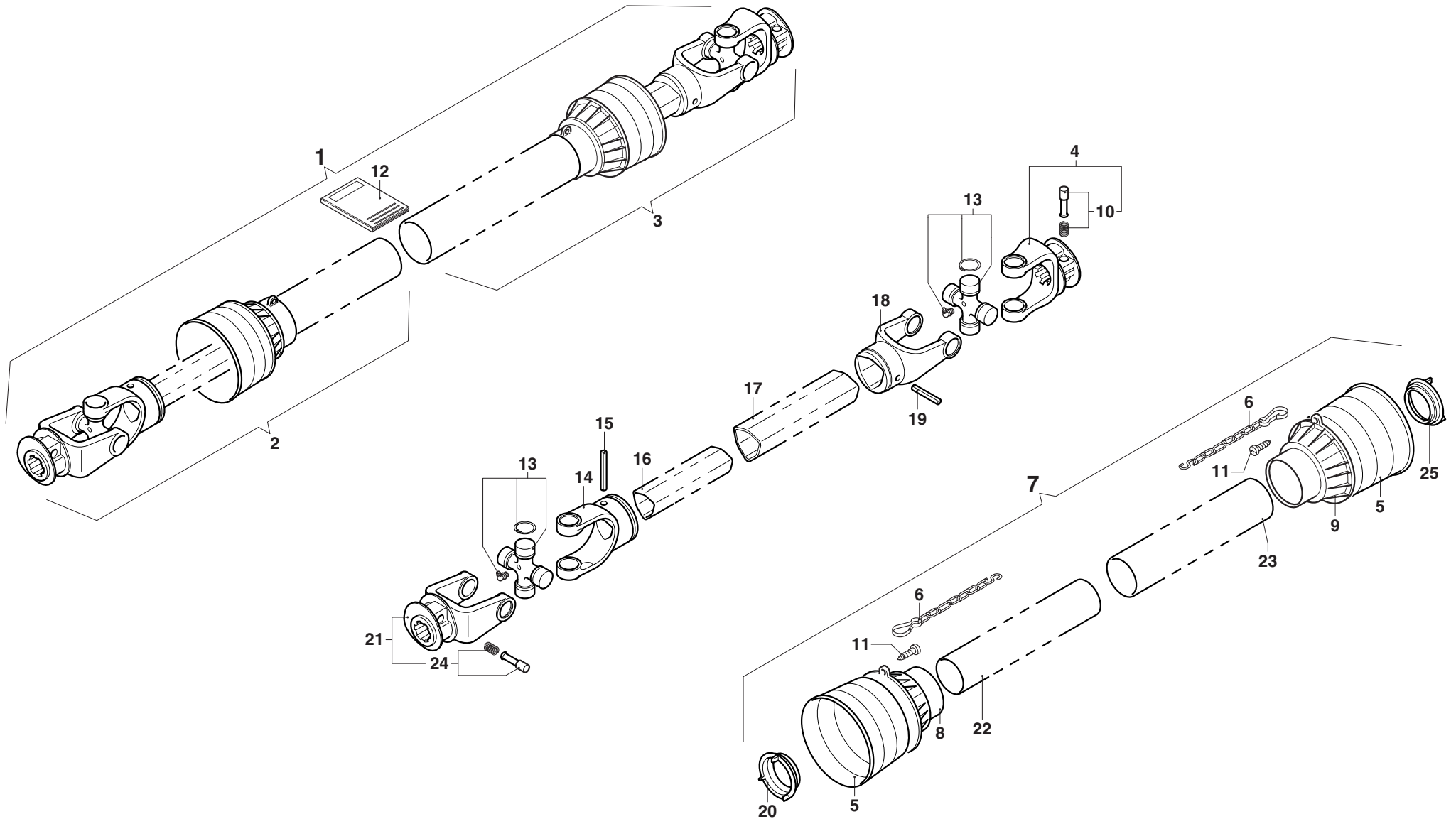

MURATORI MR

TAV. 14.0

POS.	N° CODICE	Q.	DESCRIZIONE	DESIGNATION	BENENNUNG	DESCRIPTION	DESIGNAZIONE	Da matr. De nr. serie Vom Seriennr. From serial nr.	Fino matr. Jusqu'au nr. serie Bis Seriennr. Up to serial nr.
1	AB210SFD0	1	ALBERO CARDANICO COMPLETO	ARBRE A JOINTS DE CARDAN	KARDANWELLE	PTO SHAFT			
2	B2N081CE1001	1	SEMIALBERO INTERNO	DEMI-ARBRE INTERIEUR	INNENHALBWELLE	INTERNAL HALF SHAFT			
3	B2N081CE2001	1	SEMIALBERO ESTERNO	DEMI-ARBRE EXTERIEUR	AUSSENHALBWELLE	EXTERNAL HALF SHAFT			
4	0800203	1	FORCELLA	FOURCHE	GABEL	YOKE			
5	021902C001	2	CUFFIA	CAPOUCHON	HAUBE	GUARD			
6	0252000001	2	CATENA	CHAINE	KETTE	CHAIN			
7	083CE02051	1	PROTEZIONE	PROTECTION	SCHUTZ	GUARD			
8	025402C002	1	PROTEZIONE INTERNA	PROTECTION INTERIEURE	INNENSCHUTZ	INTERNAL GUARD			
9	025402C001	1	PROTEZIONE ESTERNA	PROTECTION EXTERIEURE		AUSSENSCHUTZ	EXTERNAL GUARD		
10	0986014047	1	PULSANTE	BOUTON	DRUCKKNOPF	PUSH BOTTON			
11	0998052242	6	VITE	VIS	SCHRAUBE	SCREW			
12	09872101	1	MANUALE ISTRUZIONI	MANUEL D'UTILISATION ET D'ENTRETIEN	BETRIEBS- UND WARTUNGSANLEITUNG	USE AND MAINTENANCE MANUAL			
13	08202	2	CROCIERA	CROISILLON	KREUZSTÜCK	SPIDER			
14	08002011	1	FORCELLA	FOURCHE	GABEL	YOKE			
15	098700850	1	SPINA ELASTICA	GOUPILLE ELASTIQUE	SPANNSTIFT	ELASTIC PIN			
16	09881294100	1	TUBO INTERNO	TUBE INTERIEUR	INNENROHR	INTERNAL TUBE			
17	09881363100	1	TUBO ESTERNO	TUBE EXTERIEUR	AUSSENROHR	EXTERNAL TUBE			
18	08002021	1	FORCELLA	FOURCHE	GABEL	YOKE			
19	098700855	1	SPINA ELASTICA	GOUPILLE ELASTIQUE	SPANNSTIFT	ELASTIC PIN			
20	025502C002	1	GHIERA	FRETTE	NUTMUTTER	RING NUT			
21	0800203C	1	FORCELLA	FOURCHE	GABEL	YOKE			
22	0988955NB081	1	TUBO INTERNO	TUBE INTERIEUR	INNENROHR	INTERNAL TUBE			
23	0988961NB081	1	TUBO ESTERNO	TUBE EXTERIEUR	AUSSENROHR	EXTERNAL TUBE			
24	0986014042	1	PULSANTE	BOUTON	DRUCKKNOPF	PUSH BOTTON			
25	025502C001	1	GHIERA	FRETTE	NUTMUTTER	RING NUT			



MURATORI S.p.A.

Via Pavarello, 21 - 41051 Castelnuovo Rangone (MO) Italy - Tel. 059.5330611 Fax 059.537259

www.muratoriequip.it *info@muratoriequip.it*

Capitale sociale Euro 480.000 interamente versato

Registro Imprese di Modena

Codice fiscale e numero d'iscrizione: 00708860366