



MURATORI

**TIPO-TYPE-TYP
MRP1 120÷210 ID**

**CATALOGO RICAMBI
Catalogue Pièces Detachées
Ersatzteilkatalog
Spare Parts Catalogue
Catálogo Recambios**

EDIZIONE 11/2020



NORME PER LE ORDINAZIONI - COMMANDES/NORMES - BESTELLNORMEN - HOW TO ORDER

MRP1
120÷210 ID

Per ordinare parti di ricambio specificare:

- tipo e matricola della macchina (apposti sulla macchina o sui documenti di acquisto);
- numero del riferimento del pezzo nel disegno (Pos.), numero della tavola (Tav.) e numero di codice

N.B.: le indicazioni destro o sinistro vengono date guardando la macchina da dietro.

Pour les commandes de pièces de rechange veuillez spécifier:

- *type et numéro de série de la machine (indiqués sur la machine et sur le bon d'achat);*
- *numéro de référence du pièce sur le plan (Pos.), numéro du plan (Tav.) et numéro de code (codice)*

N.B.: *les indications droite ou gauche sont données en regardant la machine par derrière.*

Zum Bestellen von Ersatzteilen folgendes angeben:

- *Typ und Serien-Nr. der Maschine (zu finden auf der Maschine oder der Einkaufspapieren);*
- *Bezug-Nr. des Ersatzteils auf der Zeichnung (Pos.), Zeichnungsnummer (Tav.) und Kodenummer (codice)*

N.B.: *die Angaben rechts und links verstehen sich so, dass man hinter der Maschine steht.*

When ordering spare parts specify:

- machine type and serial number (found on the machine or on the purchasing documents);
- reference number of the part on the relative drawing (Pos.) number of the drawing (Tav.) and part number (codice)

N.B.: right-hand or left-hand indications are made by viewing the machine from the rear.

TAV. 1.0

GRUPPO TELAIO
ENSEMBLE CHASSIS
SATZ FÜR RAHMEN
KIT FOR FRAME

TAV. 2.0

TRASMISSIONE ROTORI
TRANSMISSION ROTORS
ROTOREN ANTRIEB
ROTORS TRANSMISSION

TAV. 2.1

TRASMISSIONE ROTORI - 2000 RPM
TRANSMISSION ROTORS - 2000 RPM
ROTOREN ANTRIEB - 2000 RPM
ROTORS TRANSMISSION - 2000 RPM

TAV. 3.0

GRUPPO MOTORE IDRAULICO
GROUPE MOTEUR HYDRAULIQUE
HYDRAULIKMOTORGRUPPE
HYDRAULIC MOTOR GROUP

TAV. 4.0

IMPIANTO IDRAULICO (17 cc)
INSTALLATION HYDRAULIQUE
HYDRAULISCHEANLAGE
HYDRAULIC SYSTEM

TAV. 4.1

IMPIANTO IDRAULICO (26 cc) - (40 l)
INSTALLATION HYDRAULIQUE
HYDRAULISCHEANLAGE
HYDRAULIC SYSTEM

TAV. 4.2

IMPIANTO IDRAULICO (36 cc) - (55 l)
INSTALLATION HYDRAULIQUE
HYDRAULISCHEANLAGE
HYDRAULIC SYSTEM

TAV. 4.3

KIT VALVOLA PORTATA COMPENSATA (OPZIONALE) (17-20-26 cc)
KIT VALVE DE PRIORITÉ (OPTION)
KIT AUSGLEICHVENTIL (ZUBEHÖR)
KIT FLOW SHUTTER VALVE (OPTIONAL)

TAV. 4.4

KIT VALVOLA PORTATA COMPENSATA (OPZIONALE) (36 cc)
KIT VALVE DE PRIORITÉ (OPTION)
KIT AUSGLEICHVENTIL (ZUBEHÖR)
KIT FLOW SHUTTER VALVE (OPTIONAL)

TAV. 5.0

VERSIONE "MULCHING"
VERSION "MULCHING"
"MULCHING" VERSION
"MULCHING" VERSION

TAV. 6.0

ATTACCO FRONTALE STANDARD
ATTELAGE FRONTAL
FRONTANBAU
FRONT LINKAGE

TAV. 7.0

ATTACCO FRONTALE RAPIDO
ATTELAGE FRONTAL RAPIDE
FRONTKUPPELDREIECK
QUICK FRONT LINKAGE

TAV. 7.1

ATTACCO BASE
ATTELAGE BASE
BASISANBAU
FRONT BASE

TAV. 7.2

ATTACCO MULTIFUNZIONE
CONNEXION MULTI-TASKING
MULTITASKING ANSCHLUSS
MULTI-TASKING LINKAGE

TAV. 7.3

ATTACCO "MUSTANG"
CONNEXION "MUSTANG"
"MUSTANG" ANSCHLUSS
"MUSTANG" LINKAGE

TAV. 7.4

ATTACCO "TORO DINGO"
CONNEXION "TORO DINGO"
"TORO DINGO" ANSCHLUSS
"TORO DINGO" LINKAGE

TAV. 7.5

ATTACCO "WEIDEMANN"
CONNEXION "WEIDEMANN"
"WEIDEMANN" ANSCHLUSS
"WEIDEMANN" LINKAGE

TAV. 7.6

ATTACCO "KNIKMOPS"
CONNEXION "KNIKMOPS"
"KNIKMOPS" ANSCHLUSS
"KNIKMOPS" LINKAGE

TAV. 7.7

ATTACCO "TOBROCO GIANT"
CONNEXION "TOBROCO GIANT"
"TOBROCO GIANT" ANSCHLUSS
"TOBROCO GIANT" LINKAGE

TAV. 7.8

ATTACCO "SCHAEFFER"
CONNEXION "SCHAEFFER"
"SCHAEFFER" ANSCHLUSS
"SCHAEFFER" LINKAGE

TAV. 7.9

ATTACCO "SCHAEFFER" (B)
CONNEXION "SCHAEFFER" (B)
"SCHAEFFER" (B) ANSCHLUSS
"SCHAEFFER" (B) LINKAGE

TAV. 7.10

ATTACCO "SCHAEFFER" (NEW)
CONNEXION "SCHAEFFER" (NEW)
"SCHAEFFER" (NEW) ANSCHLUSS
"SCHAEFFER" (NEW) LINKAGE

TAV. 7.11

ATTACCO "KNIKMOPS" (KM 120 - KM 130)
CONNEXION "KNIKMOPS" (KM 120 - KM 130)
"KNIKMOPS" ANSCHLUSS (KM 120 - KM 130)
"KNIKMOPS" LINKAGE (KM 120 - KM 130)

TAV. 7.12

ATTACCO "SKID - STEER"
CONNEXION "SKID - STEER"
"SKID - STEER" ANSCHLUSS
"SKID - STEER" LINKAGE

TAV. 8.0

INGRASSATORI ESTERNI
GRAISSAGE CENTRALISE
SAMMELSCHMIERUNG
GREASE EXTENSIONS

TAV. 9.0

RUOTINO ANTISCALPO
ROULEAU ANTICHOC
GEGENSTOSSIGE ROLLE
ANTISCALPING ROLL

TAV. 10.0

RUOTE PNEUMATICHE
ROUES PNEUMATIQUES
PNEURÄDER
TYRE WHEELS

TAV. 10.1

RUOTE PNEUMATICHE (150÷210)
ROUES PNEUMATIQUES (150÷210)
PNEURÄDER (150÷210)
TYRE WHEELS (150÷210)

TAV. 11.0

ALBERO CARDANICO COMPLETO
ARBRE A JOINTS DE CARDAN
KARDANWELLE
PTO SHAFT

TAV. 12.0

ALBERO CARDANICO COMPLETO
ARBRE A JOINTS DE CARDAN
KARDANWELLE
PTO SHAFT

TAV. 13.0

ALBERO CARDANICO COMPLETO
ARBRE A JOINTS DE CARDAN
KARDANWELLE
PTO SHAFT

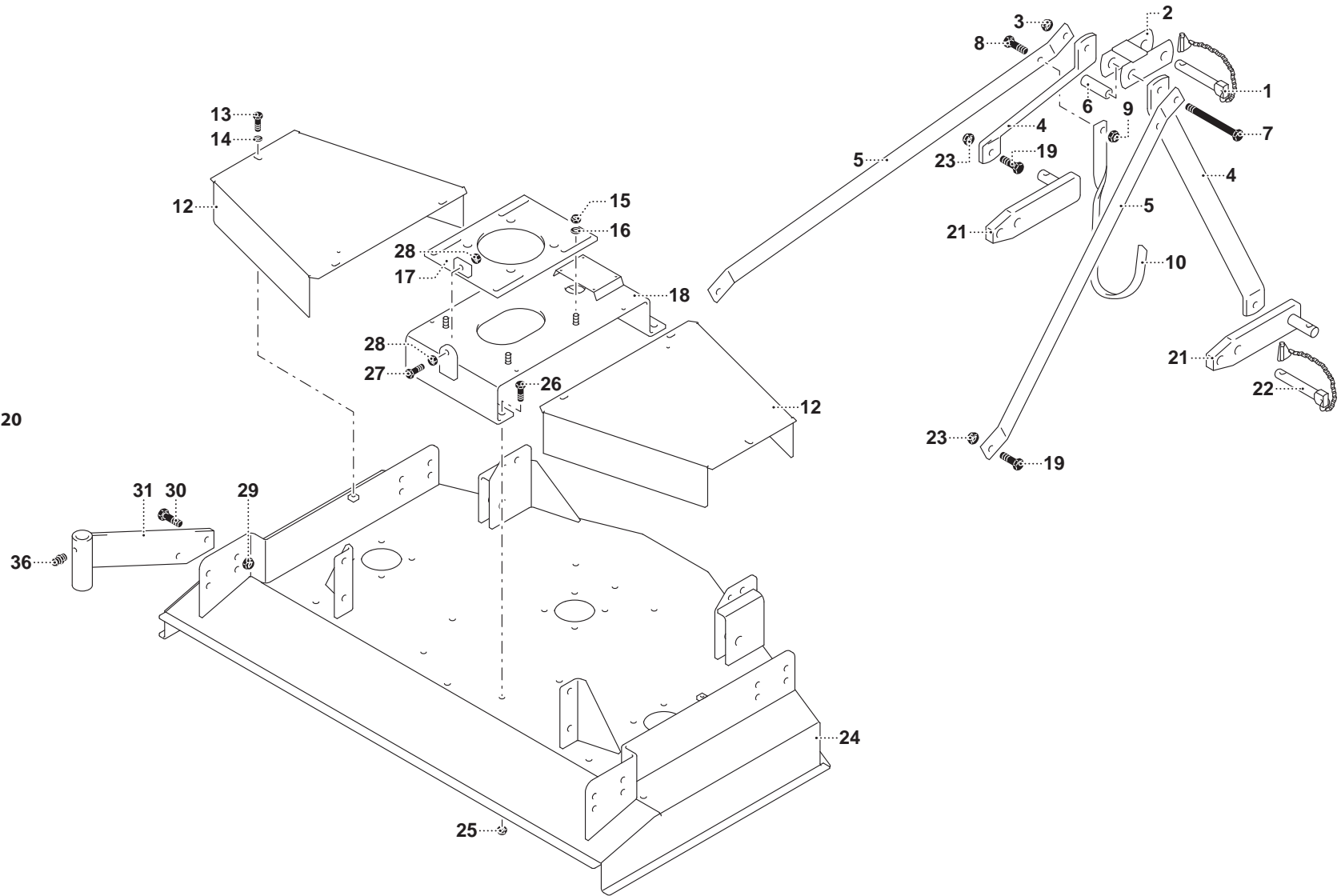
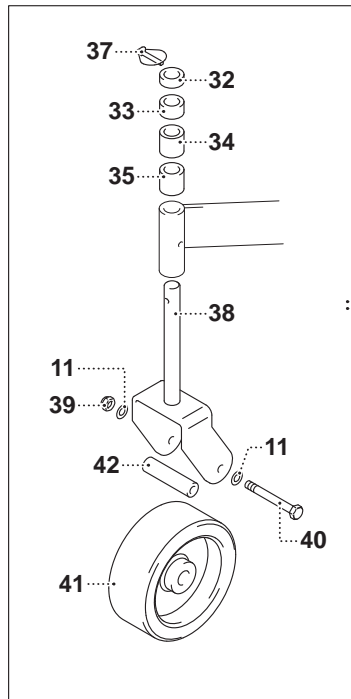

MURATORI MRP1 120÷210 ID
TAV. 1.0

POS.	N° CODICE	Q.	DESCRIZIONE	DESIGNATION	BENENNUNG	DESCRIPTION	DESIGNAZIONE	Da matr.	Fino matr.
								De nr. serie Vom Seriennr. From serial nr.	Jusqu'au nr. serie Bis Seriennr. Up to serial nr.
1	38024100	1	PERNO	PIVOT	BOLZEN	PIN			
2	40237800	1	ATTACCO	ATTACHE	ANSCHLUSS	ATTACHMENT			
3	62010600	1	DADO	ECROU	MUTTER	NUT	M 12 x 1,75 AUTOBLOCC.		
4	30178900	2	TIRANTE	TIRANT	STANGE	TIEROD			
5	30182800	2	TIRANTE	TIRANT	STANGE	TIEROD	120		
5	30205300	2	TIRANTE	TIRANT	STANGE	TIEROD	135		
5	30182900	2	TIRANTE	TIRANT	STANGE	TIEROD	150		
5	30183000	2	TIRANTE	TIRANT	STANGE	TIEROD	180		
5	30205400	2	TIRANTE	TIRANT	STANGE	TIEROD	210		
6	32021400	1	DISTANZIALE	ENTRETOISE	DISTANZSTÜCK	SPACER			
7	60011900	1	VITE	VIS	SCHRAUBE	SCREW	TE 12 x 120 UNI 5737		
8	60021300	1	VITE	VIS	SCHRAUBE	SCREW	TE 10 x 30 UNI 5739 8.8 ZNT		
9	62010400	1	DADO	ECROU	MUTTER	NUT	M 10 x 1,5 AUTOBLOCC.		
10	30120100	1	GANCIO	CROCHET	HAKEN	HOOK			
11	32174900	8	SPESSORE	EPAISSEUR	BEILAGERING	SPACER			
12	39259200	2	CARTER	CARTER	SCHUTZABDECKUNG	CASING	120		
12	39305000	2	CARTER	CARTER	SCHUTZABDECKUNG	CASING	135		
12	39259300	2	CARTER	CARTER	SCHUTZABDECKUNG	CASING	150		
12	39259400	2	CARTER	CARTER	SCHUTZABDECKUNG	CASING	180		
12	39305100	2	CARTER	CARTER	SCHUTZABDECKUNG	CASING	210		
13	60024600	6	VITE	VIS	SCHRAUBE	SCREW	TE 8 x 12 UNI 5739		
14	61004700	6	RONDELLA	RONDELLE	SCHEIBE	WASHER	PIANA Ø 8 UNI 6592		
15	62010400	4	DADO	ECROU	MUTTER	NUT	M 10 x 1,5 AUTOBLOCC.		
16	61004900	4	RONDELLA	RONDELLE	SCHEIBE	WASHER	PIANA Ø 10 UNI 6592		
17	45194700	1	CONTROPIASTRA	CONTRE-PLAQUE	GEGENPLATTE	COUNTER PLATE			
18	40233900	1	SUPPORTO	SUPPORT	HALTERUNG	SUPPORT	120-135		

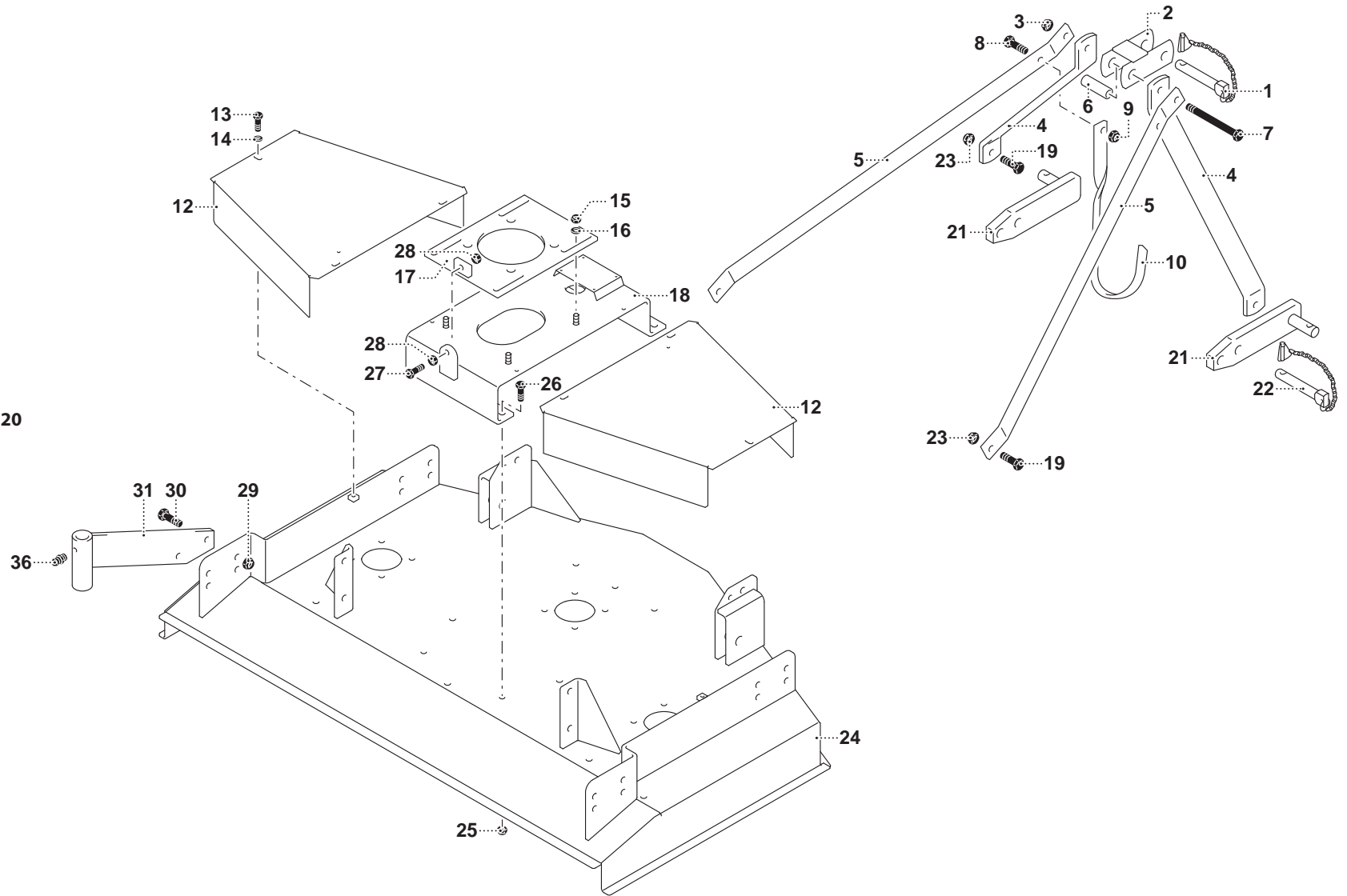
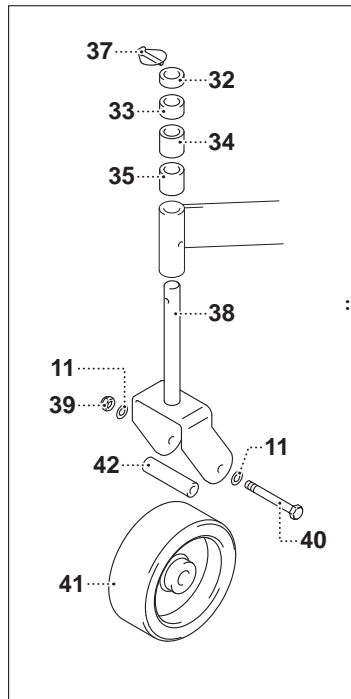

MURATORI MRP1 120÷210 ID

TAV. 1.0

POS.	N° CODICE	Q.	DESCRIZIONE	DESIGNATION	BENENNUNG	DESCRIPTION	DESIGNAZIONE	Da matr. De nr. serie Vom Seriennr. From serial nr.	Fino matr. Jusqu'au nr. serie Bis Seriennr. Up to serial nr.
18	40234000	1	SUPPORTO	SUPPORT	HALTERUNG	SUPPORT	150-180-210		
19	60021200	4	VITE	VIS	SCHRAUBE	SCREW	TE 12 x 35 UNI 5739 8.8 ZNT		
20	45168800		RUOTA RINFORZATA COMPLETA	ROUE COMPLETE RENFORCEE	KOMPLETTES VERSTÄRKTES RAD	COMPLETE REINFORCED WHEEL			
21	40239400	2	BRACCIO	BRAS	ARM	ARM			
22	38024100	2	PERNO	PIVOT	BOLZEN	PIN			
23	62010600	4	DADO	ECROU	MUTTER	NUT	M 12 x 1.75 AUTOBLOCC.		
24	41135000	1	TELAIO	CHASSIS	RAHMEN	FRAME	120		
24	41135100	1	TELAIO	CHASSIS	RAHMEN	FRAME	135		
24	41135200	1	TELAIO	CHASSIS	RAHMEN	FRAME	150		
24	41135300	1	TELAIO	CHASSIS	RAHMEN	FRAME	180		
24	41135400	1	TELAIO	CHASSIS	RAHMEN	FRAME	210		
25	62010400	2	DADO	ECROU	MUTTER	NUT	M 10 x 1.5 AUTOBLOCC.		
26	60017900	5	VITE	VIS	SCHRAUBE	SCREW	TE 10 x 25 UNI 5739 8.8 ZNT		
27	60030200	1	VITE	VIS	SCHRAUBE	SCREW	TE 10 x 80 UNI 5739		
28	62007000	2	DADO	ECROU	MUTTER	NUT	M 10 x 1.5 UNI 5588		
29	62010600	8	DADO	ECROU	MUTTER	NUT	M 12 x 1.75 AUTOBLOCC.		
30	60028200	8	VITE	VIS	SCHRAUBE	SCREW	TE 12 x 40 UNI 5739 8.8 ZNT		
31	40234200	4	STAFFA	BRIDE	BÜGEL	BRACKET			
32	32174600	4	SPESSORE	EPAISSEUR	BEILAGERING	SPACER	H = 6		
33	32174700	4	SPESSORE	EPAISSEUR	BEILAGERING	SPACER	H = 12		
34	32174900	4	SPESSORE	EPAISSEUR	BEILAGERING	SPACER	H = 24		
35	32175000	4	SPESSORE	EPAISSEUR	BEILAGERING	SPACER	H = 32		
36	64000200	4	INGRASSATORE	GRAISSEUR	SCHMIERNIPPEL	GREASE FITTING	M 6 x 1		
37	64004800	4	SPINA	GOUPILLE	STIFT	PIN	Ø 8		
38	40234300	4	FORCELLA	FOURCHE	GABEL	YOKE			

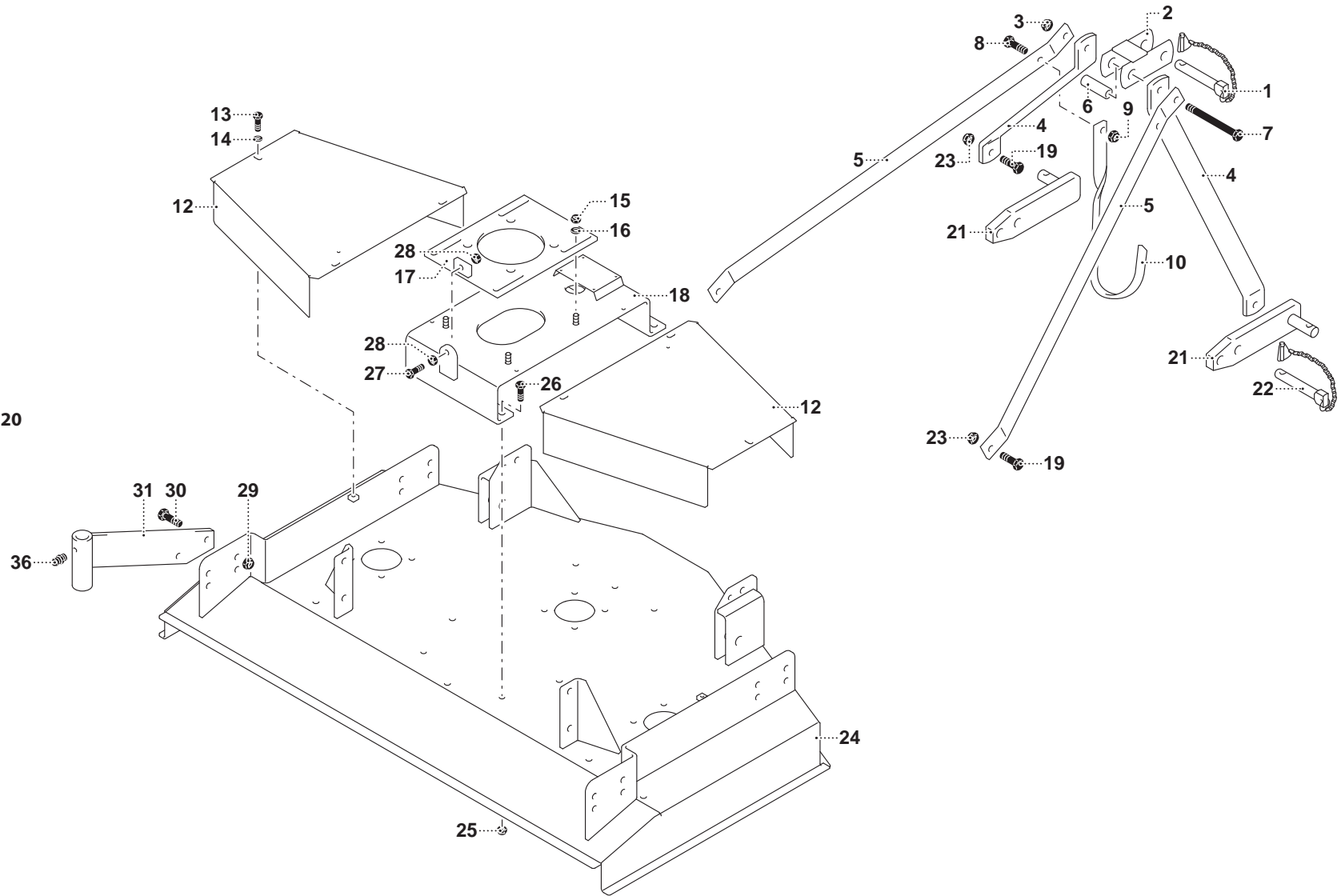
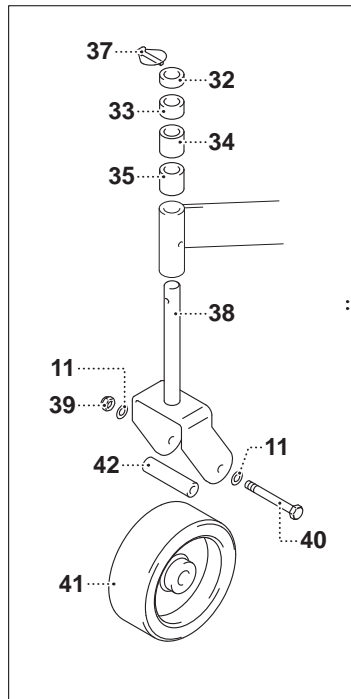

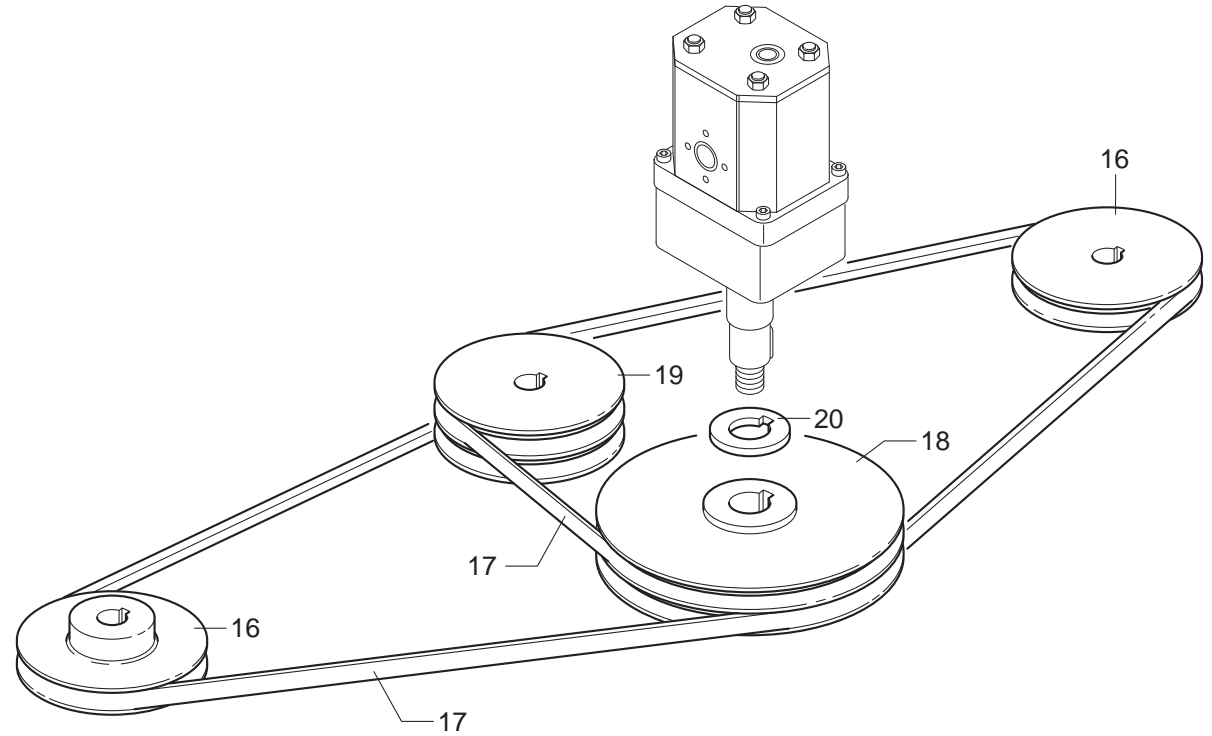
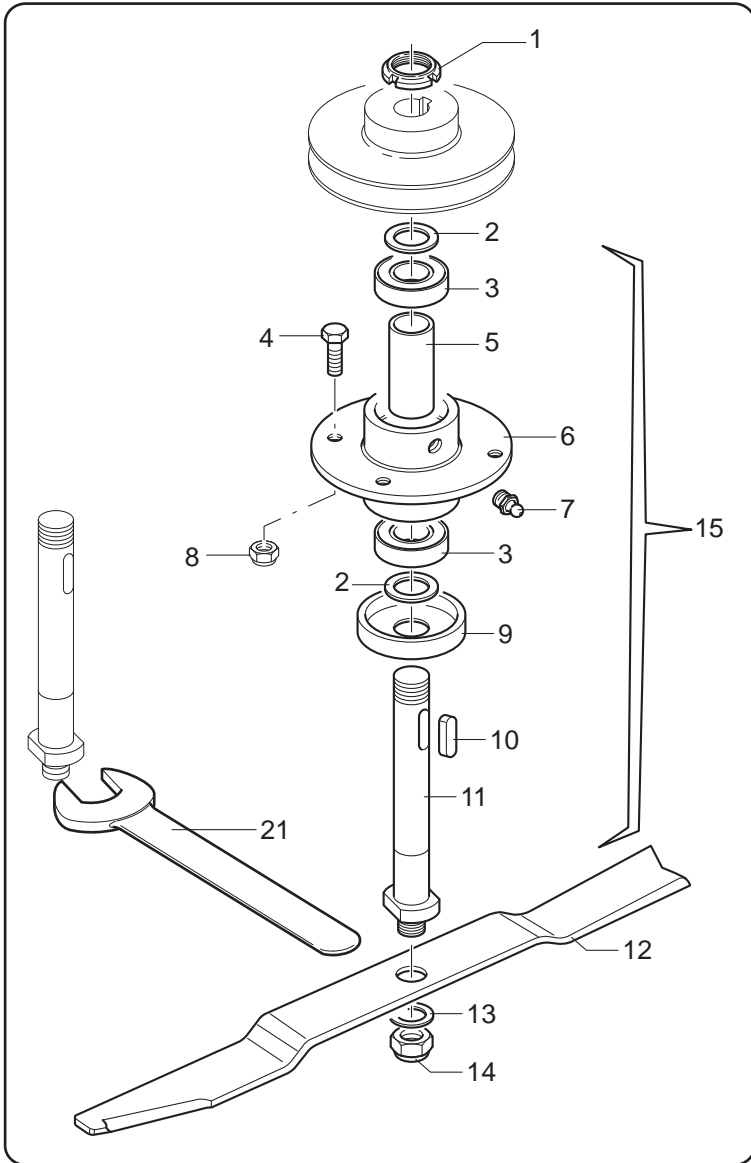

MURATORI MRP1 120÷210 ID

TAV. 2.0

POS.	N° CODICE	Q.	DESCRIZIONE	DESIGNATION	BENENNUNG	DESCRIPTION	DESIGNAZIONE	Da matr. De nr. serie Vom Seriennr. From serial nr.	Fino matr. Jusqu'au nr. serie Bis Seriennr. Up to serial nr.
1	62001200	3	GHIERA	FRETTE	NUTMUTTER	RING NUT	M 25 x 1.5 AUTOBLOCC.		
2	32174100	6	SPESSORE	EPAISSEUR	BEILAGERING	SPACER			
3	67016600	6	CUSCINETTO	ROULEMENT	LAGER	BEARING	6205 RS		
4	60021300	12	VITE	VIS	SCHRAUBE	SCREW	TE 10 x 30 UNI 5739 8.8 ZNT		
5	32174000	3	DISTANZIALE	ENTRETOISE	DISTANZSTÜCK	SPACER			
6	40234100	3	SUPPORTO	SUPPORT	HALTERUNG	SUPPORT			
7	64001800	3	INGRASSATORE	GRAISSEUR	SCHMIERNIPPEL	GREASE FITTING	M 10 x 1 DIRITTO		
8	62010400	12	DADO	ECROU	MUTTER	NUT	M 10 x 1.5 AUTOBLOCC.		
9	39261100	3	PROTEZIONE	PROTECTION	SCHUTZ	GUARD			
10	65001100	3	LINGUETTA	CLAVETTE	FEDER	KEY	8 x 7 x 30 UNI 6604		
11	31078600	3	ALBERO	ARBRE	WELLE	SHAFT			
12	12017700	3	LAMA	LAME DE COUPE	SCHNEIDKANTE	BLADE	120		
12	12021200	3	LAMA	LAME DE COUPE	SCHNEIDKANTE	BLADE	135		
12	12017800	3	LAMA	LAME DE COUPE	SCHNEIDKANTE	BLADE	150		
12	12017900	3	LAMA	LAME DE COUPE	SCHNEIDKANTE	BLADE	180		
12	12021300	3	LAMA	LAME DE COUPE	SCHNEIDKANTE	BLADE	210		
13	39077800	3	RONDELLA	RONDELLE	SCHEIBE	WASHER	PIANA Øi 19 Øe 50 SP5		
14	62011100	3	DADO	ECROU	MUTTER	NUT	M 18 x 1.5 AUTOBLOCC.		
15	45115100		MOZZO COMPLETO	ENSEMBLE MOYEU	SATZ NABE	SPINDLE ASSEMBLY			
16	68086600	2	PULEGGIA	POULIE	RIEMENSCHLEIBE	PULLEY	120		
16	68112500	2	PULEGGIA	POULIE	RIEMENSCHLEIBE	PULLEY	135		
16	68086700	2	PULEGGIA	POULIE	RIEMENSCHLEIBE	PULLEY	150-180-210		
17	68083500	2	CINGHIA	COURROIE	KEILRIEMEN	BELT	XPB1320 (120)		
17	68113000	2	CINGHIA	COURROIE	KEILRIEMEN	BELT	B56 (135)		
17	68086900	2	CINGHIA	COURROIE	KEILRIEMEN	BELT	B67 (150)		
17	68137900	2	CINGHIA	COURROIE	KEILRIEMEN	BELT	B75 (180)		

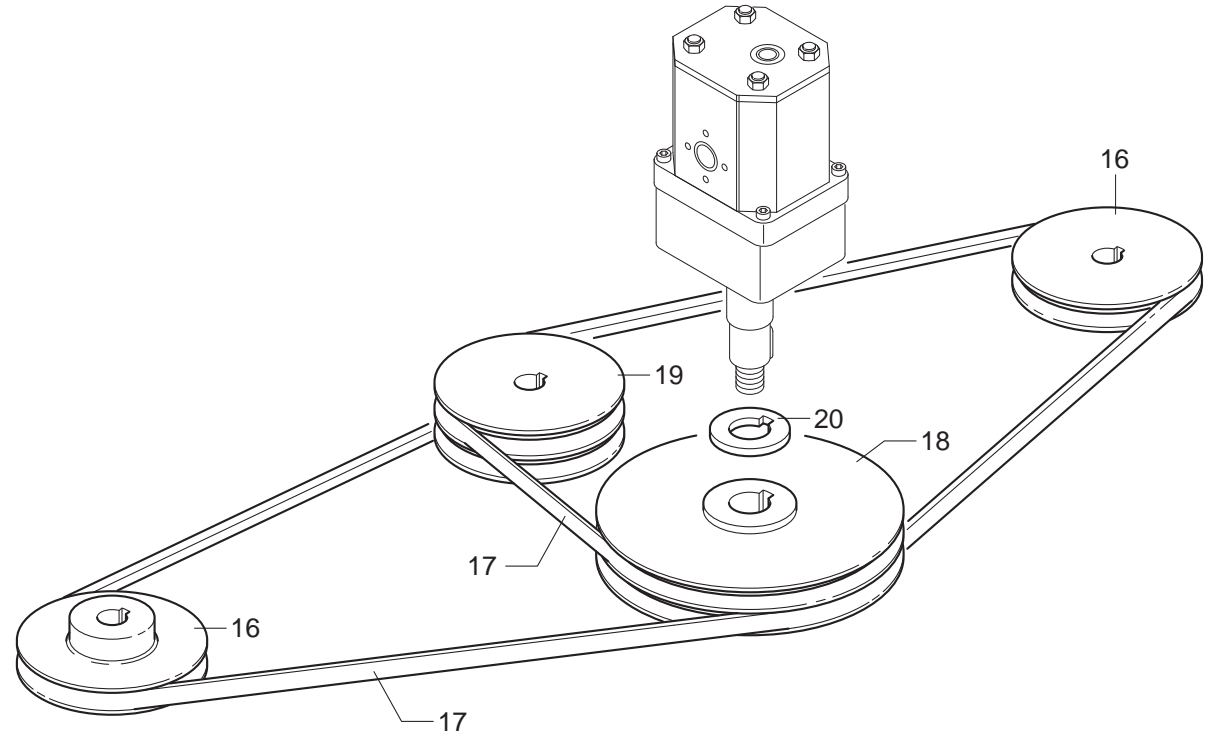
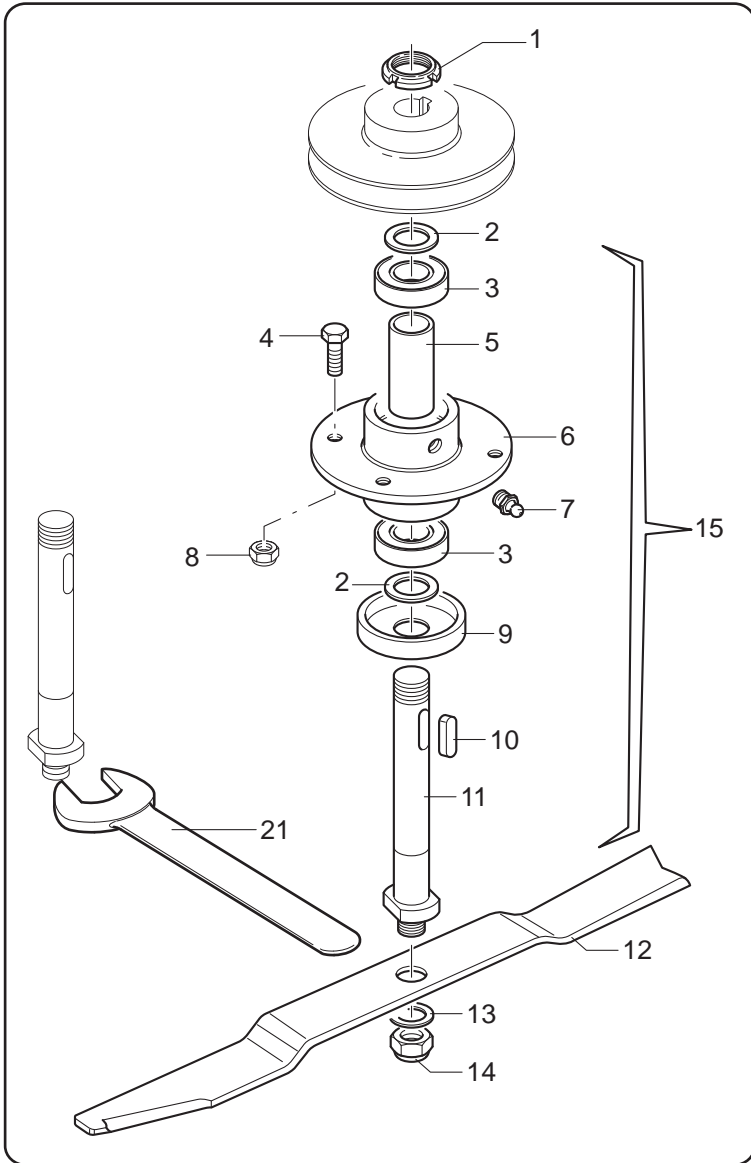

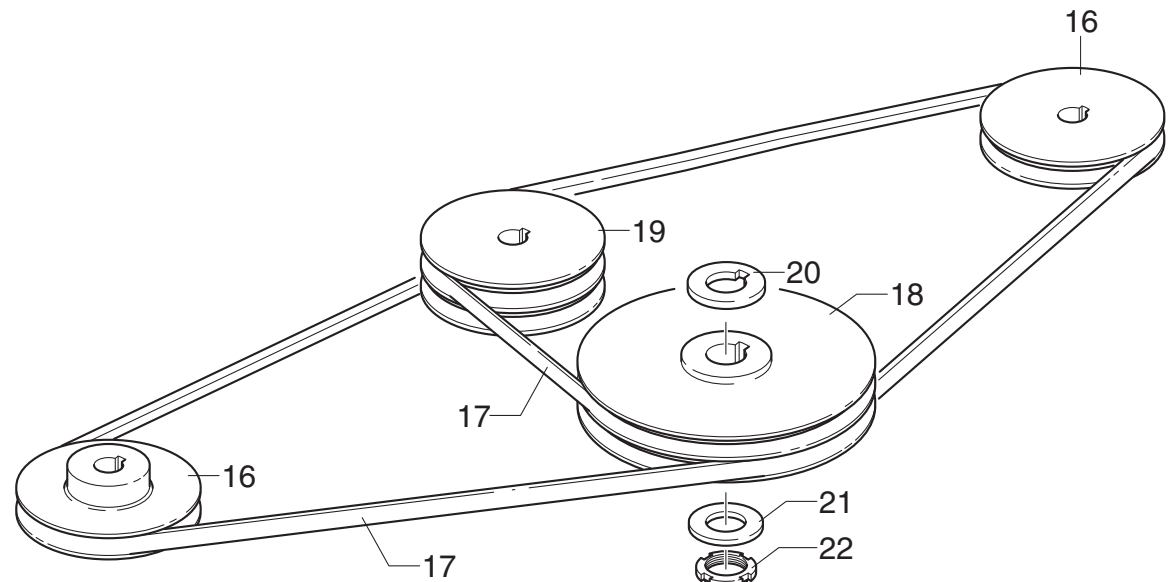
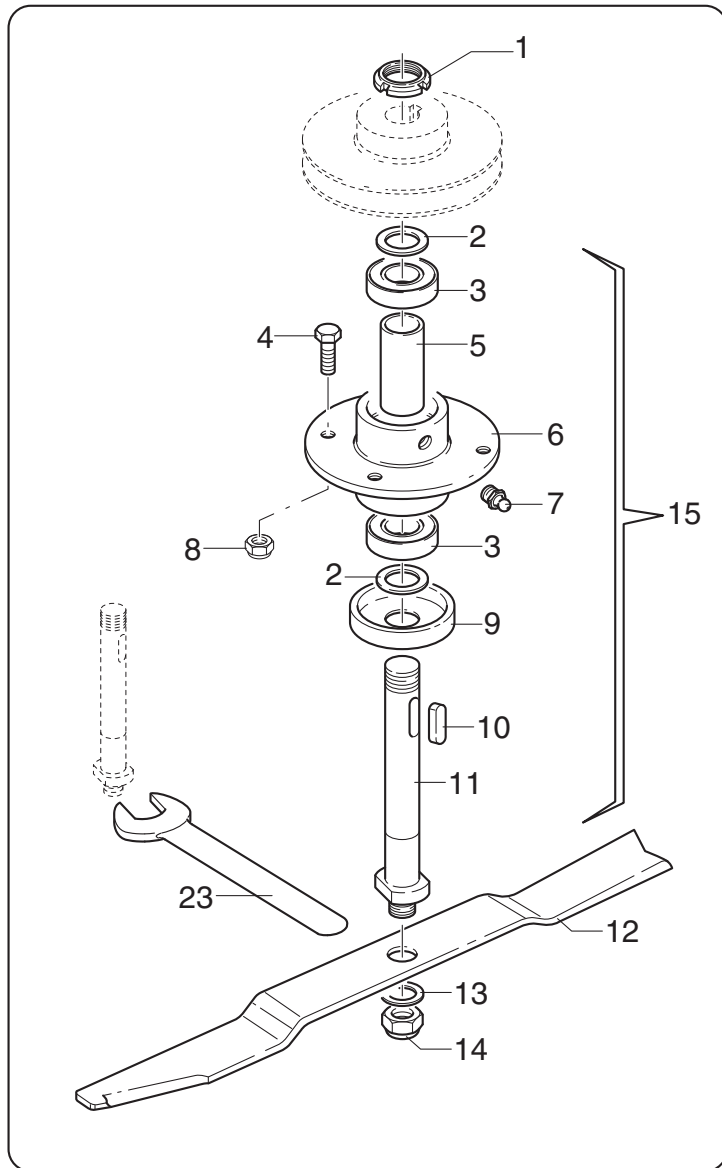

MURATORI MRP1 120÷210 ID

TAV. 2.1

POS.	N° CODICE	Q.	DESCRIZIONE	DESIGNATION	BENENNUNG	DESCRIPTION	DESIGNAZIONE	Da matr. De nr. serie Vom Seriennr. From serial nr.	Fino matr. Jusqu'au nr. serie Bis Seriennr. Up to serial nr.
1	62001200	3	GHIERA	FRETTE	NUTMUTTER	RING NUT	M 25 x 1.5 AUTOBLOCC.		
2	32174100	6	SPESSORE	EPAISSEUR	BEILAGERING	SPACER			
3	67016600	6	CUSCINETTO	ROULEMENT	LAGER	BEARING	6205 RS		
4	60021300	12	VITE	VIS	SCHRAUBE	SCREW	TE 10 x 30 UNI 5739 8.8 ZNT		
5	32174000	3	DISTANZIALE	ENTRETOISE	DISTANZSTÜCK	SPACER			
6	40234100	3	SUPPORTO	SUPPORT	HALTERUNG	SUPPORT			
7	64001800	3	INGRASSATORE	GRAISSEUR	SCHMIERNIPPEL	GREASE FITTING	M 10 x 1 DIRITTO		
8	62010400	12	DADO	ECROU	MUTTER	NUT	M 10 x 1.5 AUTOBLOCC.		
9	39261100	3	PROTEZIONE	PROTECTION	SCHUTZ	GUARD			
10	65001100	3	LINGUETTA	CLAVETTE	FEDER	KEY	8 x 7 x 30 UNI 6604		
11	31078600	3	ALBERO	ARBRE	WELLE	SHAFT			
12	12017700	3	LAMA	LAME DE COUPE	SCHNEIDKANTE	BLADE	120		
12	12021200	3	LAMA	LAME DE COUPE	SCHNEIDKANTE	BLADE	135		
12	12017800	3	LAMA	LAME DE COUPE	SCHNEIDKANTE	BLADE	150		
12	12017900	3	LAMA	LAME DE COUPE	SCHNEIDKANTE	BLADE	180		
12	12021300	3	LAMA	LAME DE COUPE	SCHNEIDKANTE	BLADE	210		
13	39077800	3	RONDELLA	RONDELLE	SCHEIBE	WASHER	PIANA Øi 19 Øe 50		
14	62011100	3	DADO	ECROU	MUTTER	NUT	M 18 x 1.5 AUTOBLOCC.		
15	45115100		MOZZO COMPLETO	ENSEMBLE MOYEU	SATZ NABE	SPINDLE ASSEMBLY			
16	68086600	2	PULEGGIA	POULIE	RIEMENSCHLEIBE	PULLEY	120		
16	68112500	2	PULEGGIA	POULIE	RIEMENSCHLEIBE	PULLEY	135		
16	68086700	2	PULEGGIA	POULIE	RIEMENSCHLEIBE	PULLEY	150-180-210		
17	68083500	2	CINGHIA	COURROIE	KEILRIEMEN	BELT	XPB1320 (120)		
17	68113000	2	CINGHIA	COURROIE	KEILRIEMEN	BELT	B56 (135)		
17	68086900	2	CINGHIA	COURROIE	KEILRIEMEN	BELT	B67 (150)		
17	68087000	2	CINGHIA	COURROIE	KEILRIEMEN	BELT	B74 (180)		

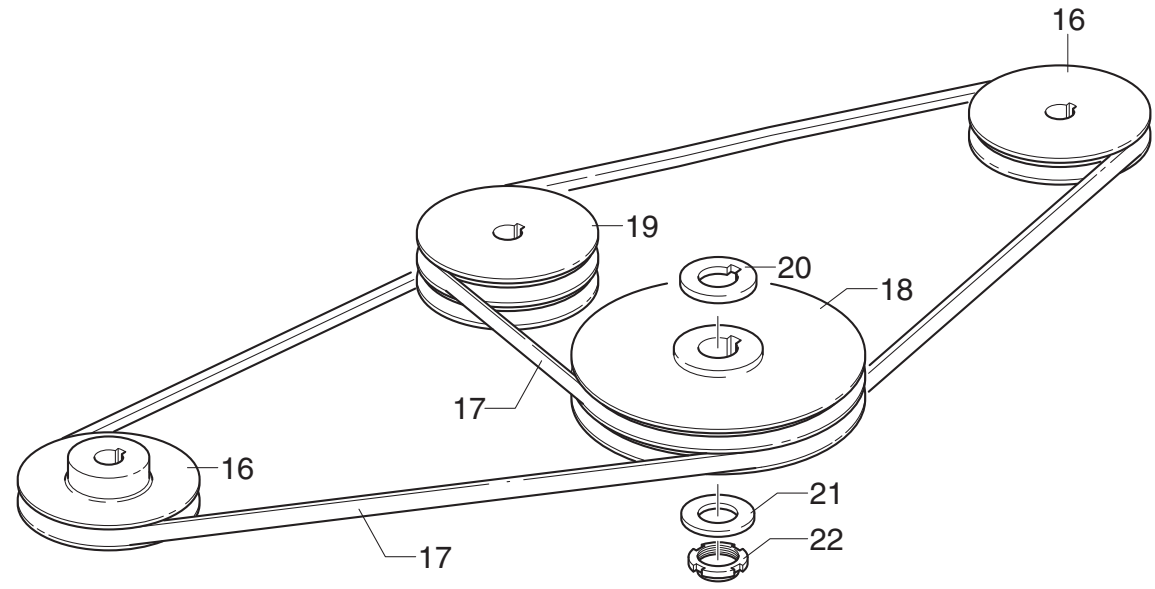
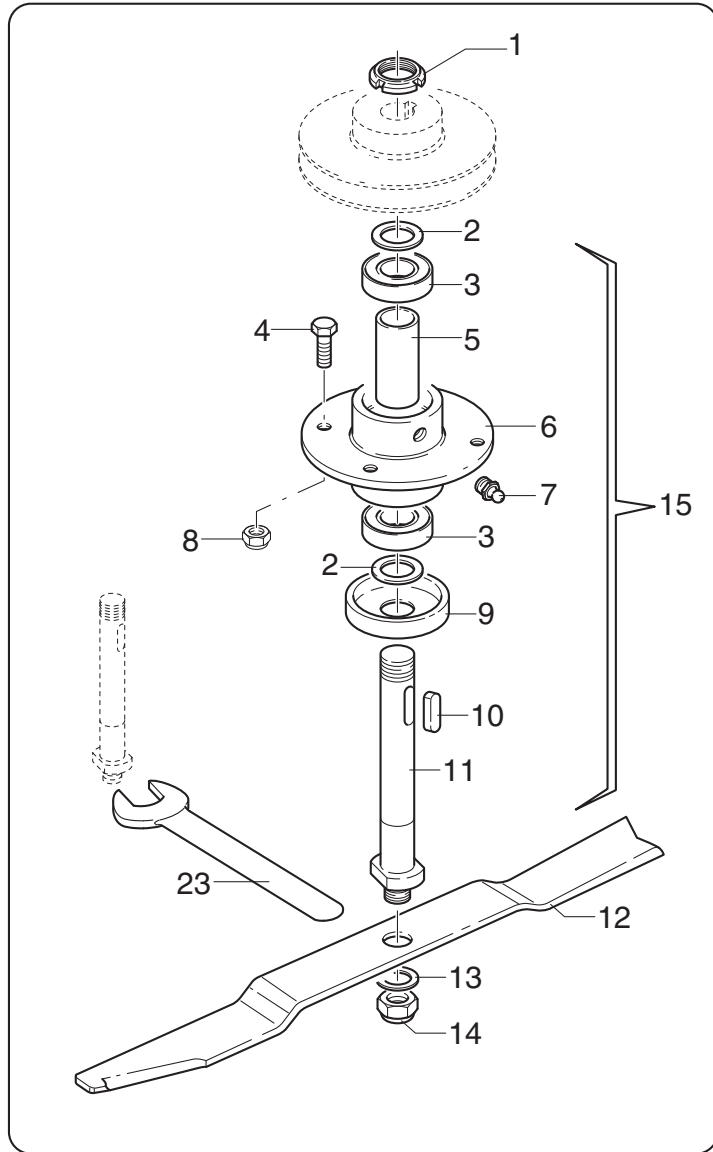

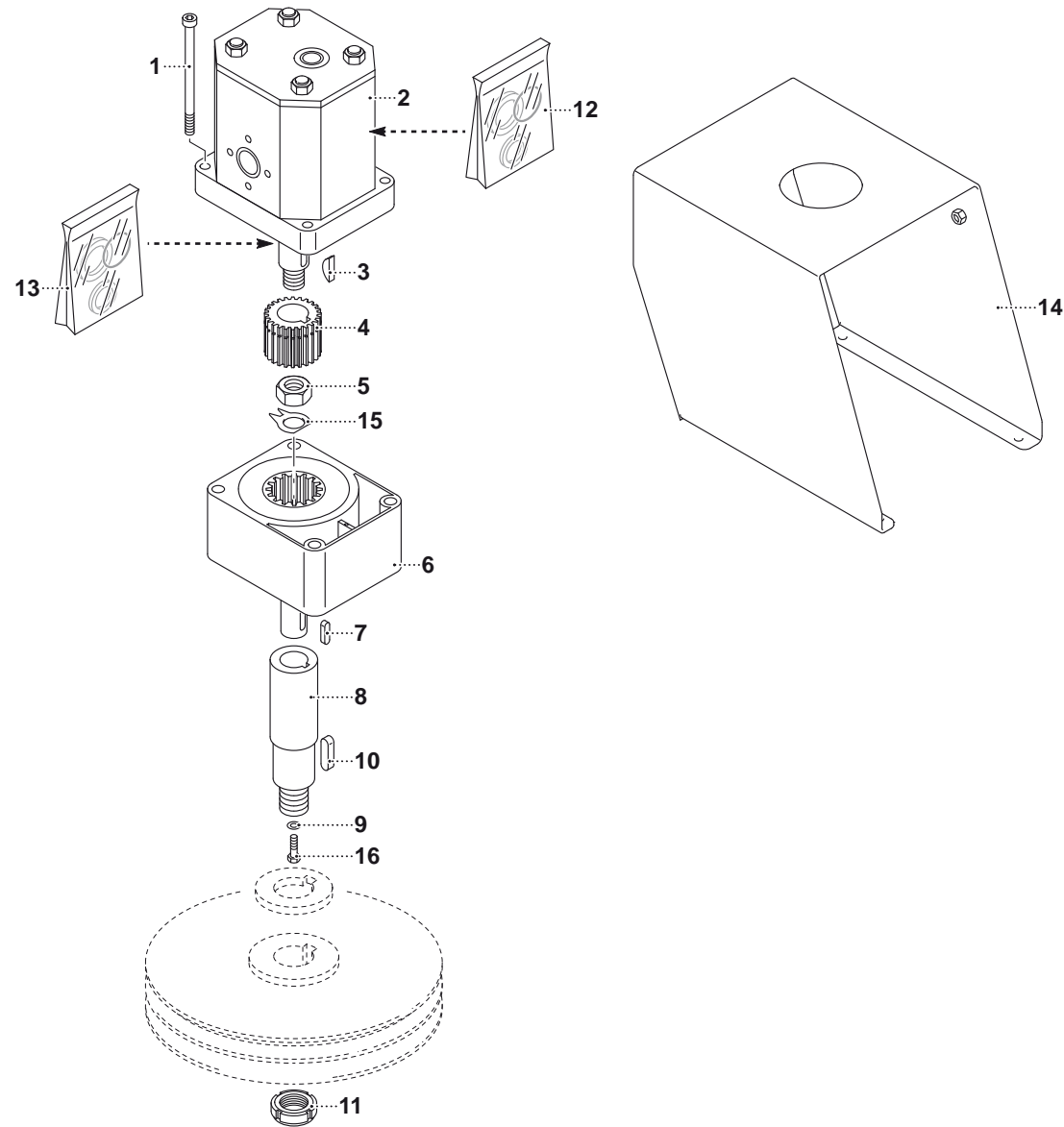

MURATORI MRP1 120÷210 ID
TAV. 3.0

POS.	N° CODICE	Q.	DESCRIZIONE	DESIGNATION	BENENNUNG	DESCRIPTION	DESIGNAZIONE	Da matr. De nr. serie Vom Seriennr. From serial nr.	Fino matr. Jusqu'au nr. serie Bis Seriennr. Up to serial nr.
1	60042900	4	VITE	VIS	SCHRAUBE	SCREW	TCEI 8x90 UNI 5931		
2	68097900	1	MOTORE IDRAULICO	MOTEUR HYDRAULIQUE	HYDRAULIKMOTOR	HYDRAULIC MOTOR	120-135 (17 cc)		137669
2	68133400	1	MOTORE IDRAULICO	MOTEUR HYDRAULIQUE	HYDRAULIKMOTOR	HYDRAULIC MOTOR	120-135 (17 cc)	137670	
2	68089400	1	MOTORE IDRAULICO	MOTEUR HYDRAULIQUE	HYDRAULIKMOTOR	HYDRAULIC MOTOR	150-180-210 (20 cc)		135743
2	68097700	1	MOTORE IDRAULICO	MOTEUR HYDRAULIQUE	HYDRAULIKMOTOR	HYDRAULIC MOTOR	(26 cc)		135953
2	68138100	1	MOTORE IDRAULICO	MOTEUR HYDRAULIQUE	HYDRAULIKMOTOR	HYDRAULIC MOTOR	(26 cc)	139546	
2	68129300	1	MOTORE IDRAULICO	MOTEUR HYDRAULIQUE	HYDRAULIKMOTOR	HYDRAULIC MOTOR	(36 cc)		135797
2	68133500	1	MOTORE IDRAULICO	MOTEUR HYDRAULIQUE	HYDRAULIKMOTOR	HYDRAULIC MOTOR	150 - 180 - 210 (20 cc)	135744	
2	68133600	1	MOTORE IDRAULICO	MOTEUR HYDRAULIQUE	HYDRAULIKMOTOR	HYDRAULIC MOTOR	(26 cc)	135954	139545
2	68135000	1	MOTORE IDRAULICO	MOTEUR HYDRAULIQUE	HYDRAULIKMOTOR	HYDRAULIC MOTOR	(36 cc)	135798	
3	65003000	1	LINGUETTA	CLAVETTE	FEDER	KEY	(17-20 cc)		
3	65003100	1	LINGUETTA	CLAVETTE	FEDER	KEY	(26 cc)		
4	31082600	1	SEMIGIUNTO	DEMI-JOINT	HALBGELENK	HALF COUPLING			
4	31090200	1	SEMIGIUNTO	DEMI-JOINT	HALBGELENK	HALF COUPLING	(26 cc - 36 cc)		
5	62016900	1	DADO	ECROU	MUTTER	NUT	(17-20 cc) M 12x1,5 UNI 5589		
5	62017000	1	DADO	ECROU	MUTTER	NUT	(26 cc) M 14x1,5 UNI 5589		
6	68089500	1	SUPPORTO	SUPPORT	HALTERUNG	SUPPORT			
6	68129400	1	SUPPORTO	SUPPORT	HALTERUNG	SUPPORT	(26 cc - 36 cc)		
7	65003200	1	LINGUETTA	CLAVETTE	FEDER	KEY	6 x 6 x 40		
8	31082500	1	ALBERO	ARBRE	WELLE	SHAFT	Gruppo 2		
8	31101100	1	ALBERO	ARBRE	WELLE	SHAFT	Gruppo 3		
9	61002500	1	RONDELLA	RONDELLE	SCHEIBE	WASHER	ELASTICA Ø 8 UNI 1750		
10	65000200	1	LINGUETTA	CLAVETTE	FEDER	KEY	10 x 8 x 35		
11	62001200	2	GHIERA	FRETTE	NUTMUTTER	RING NUT	M 25 x 1,5 AUTOBLOCC.		
12	66019800	1	KIT GUARNIZIONI MOTORE	KIT GARNITURES MOTEUR	MOTOR SATZ DICHTUNGEN	MOTOR GASKETS KIT	(17-20 cc)		137669

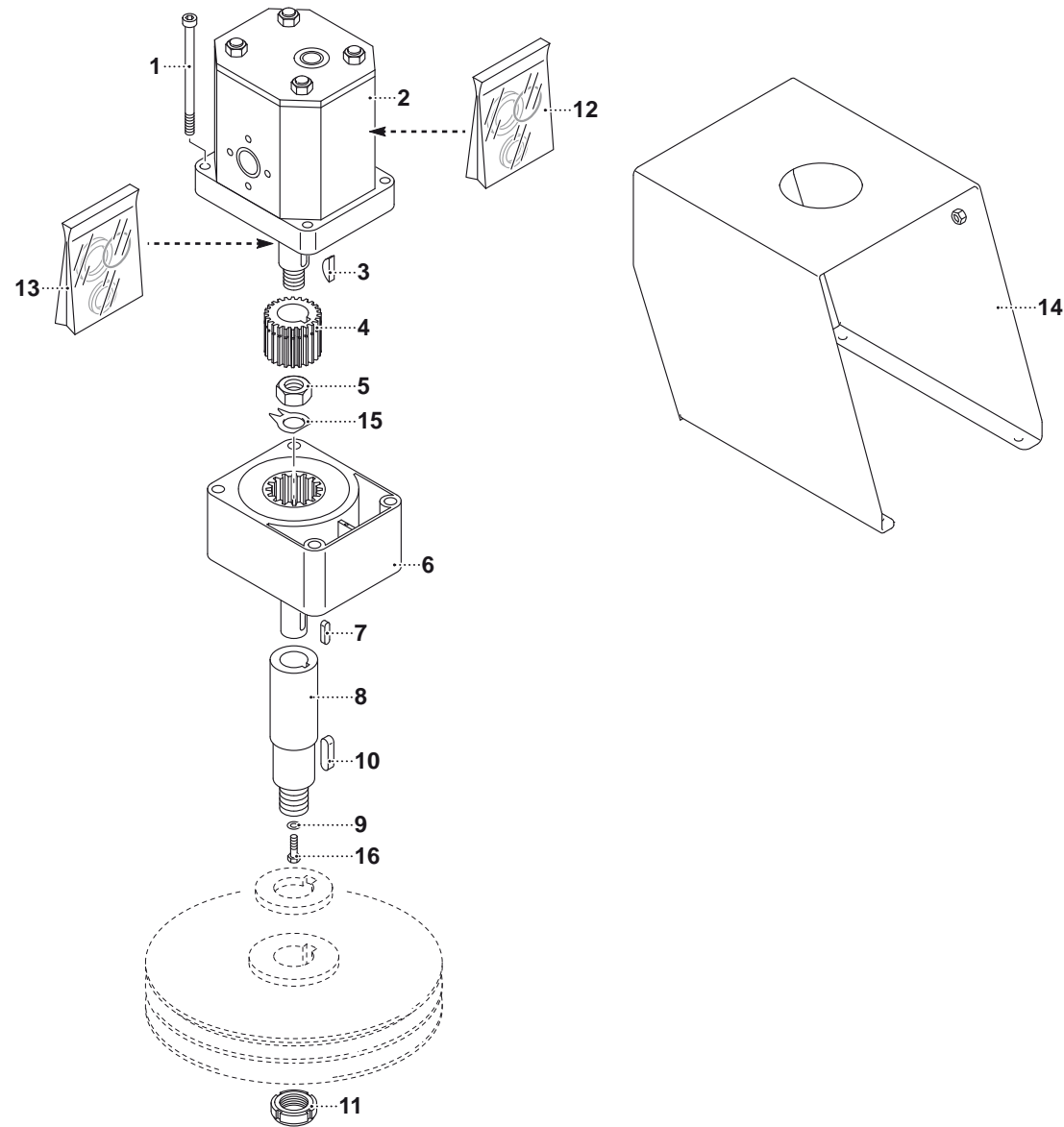

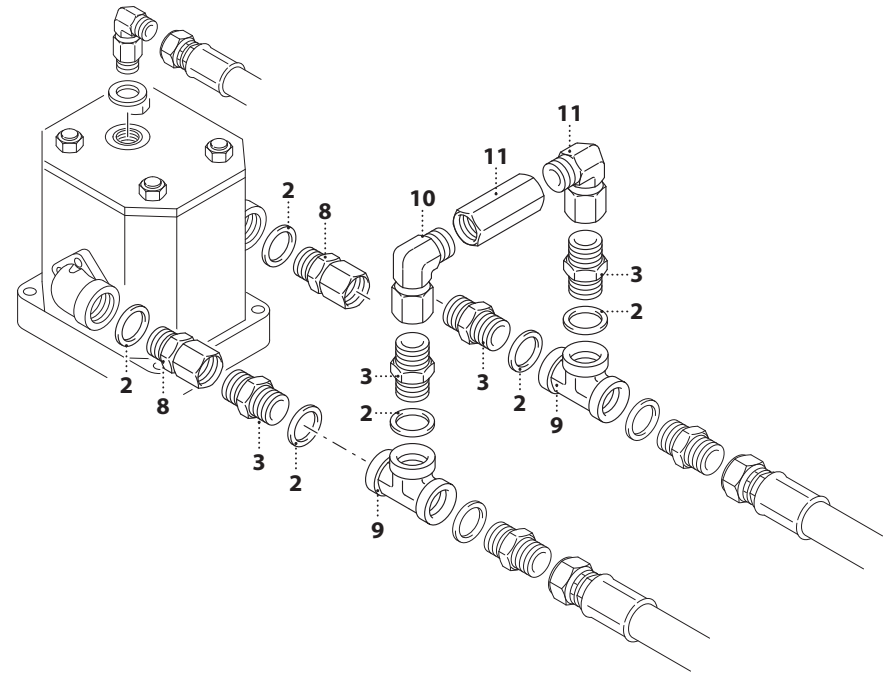
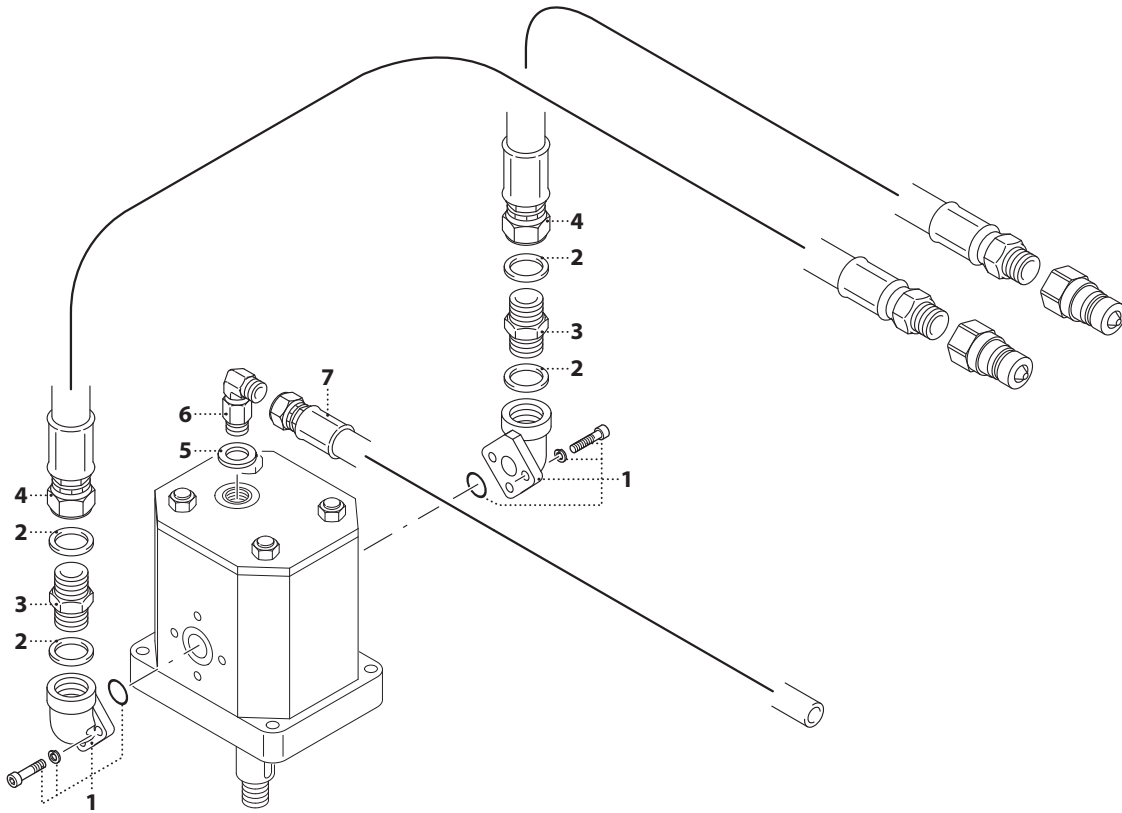

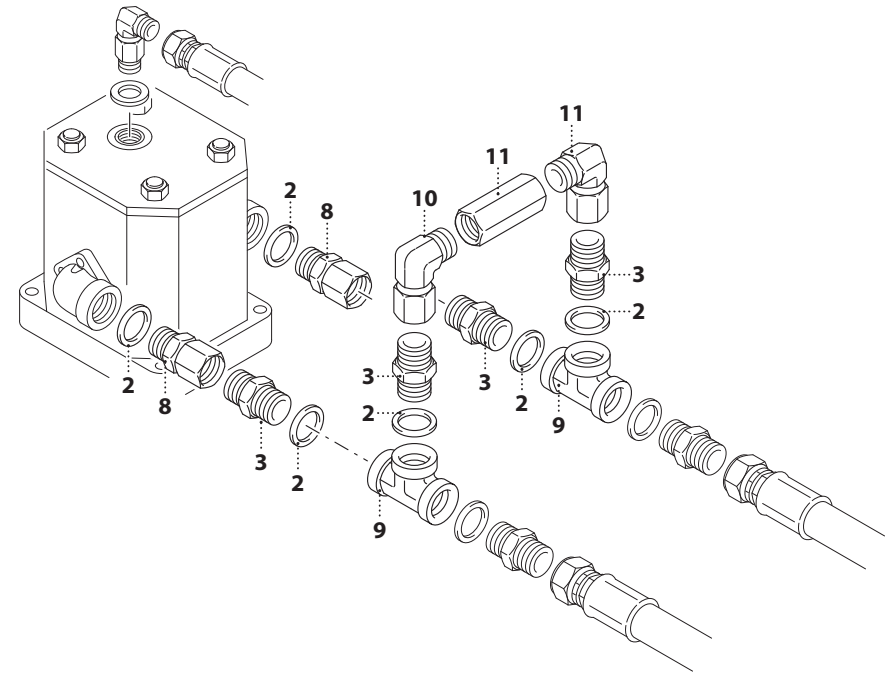
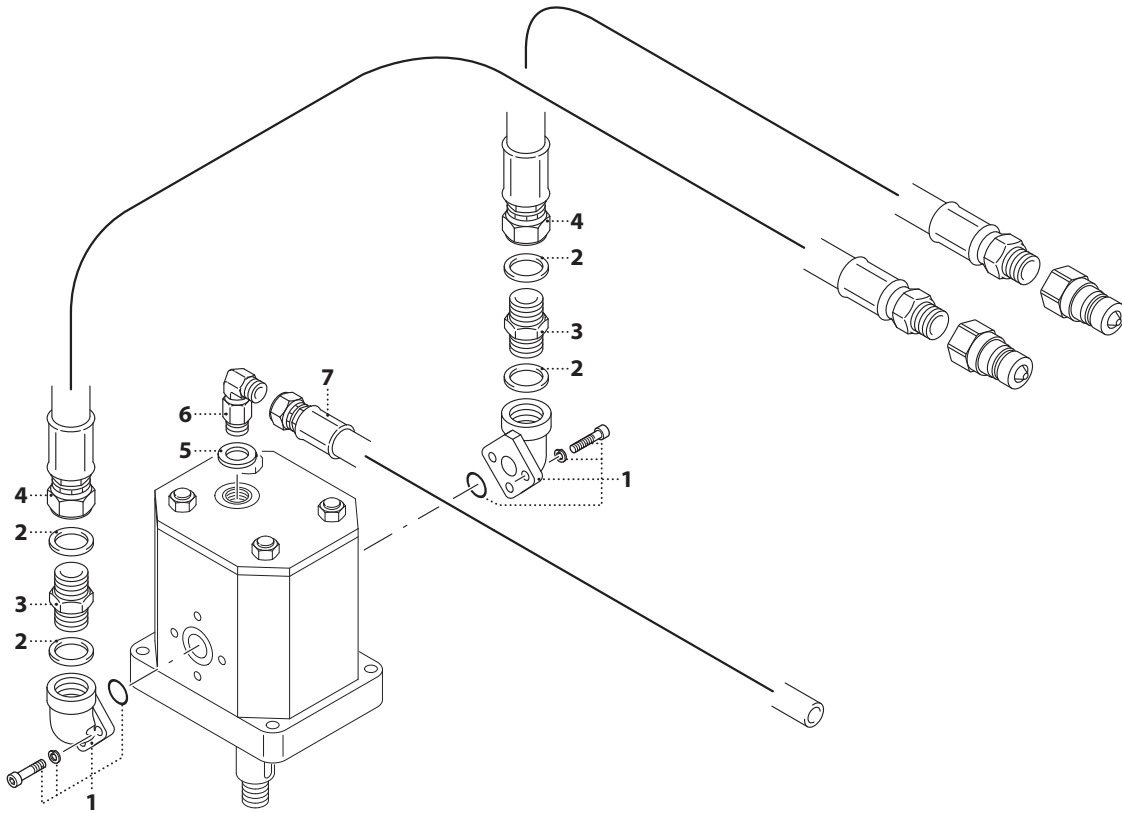

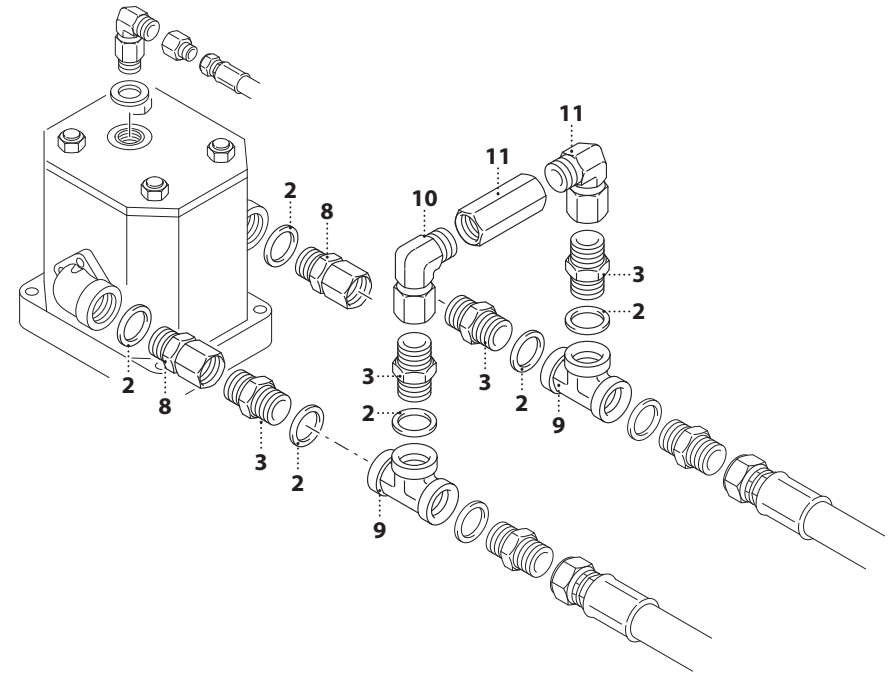
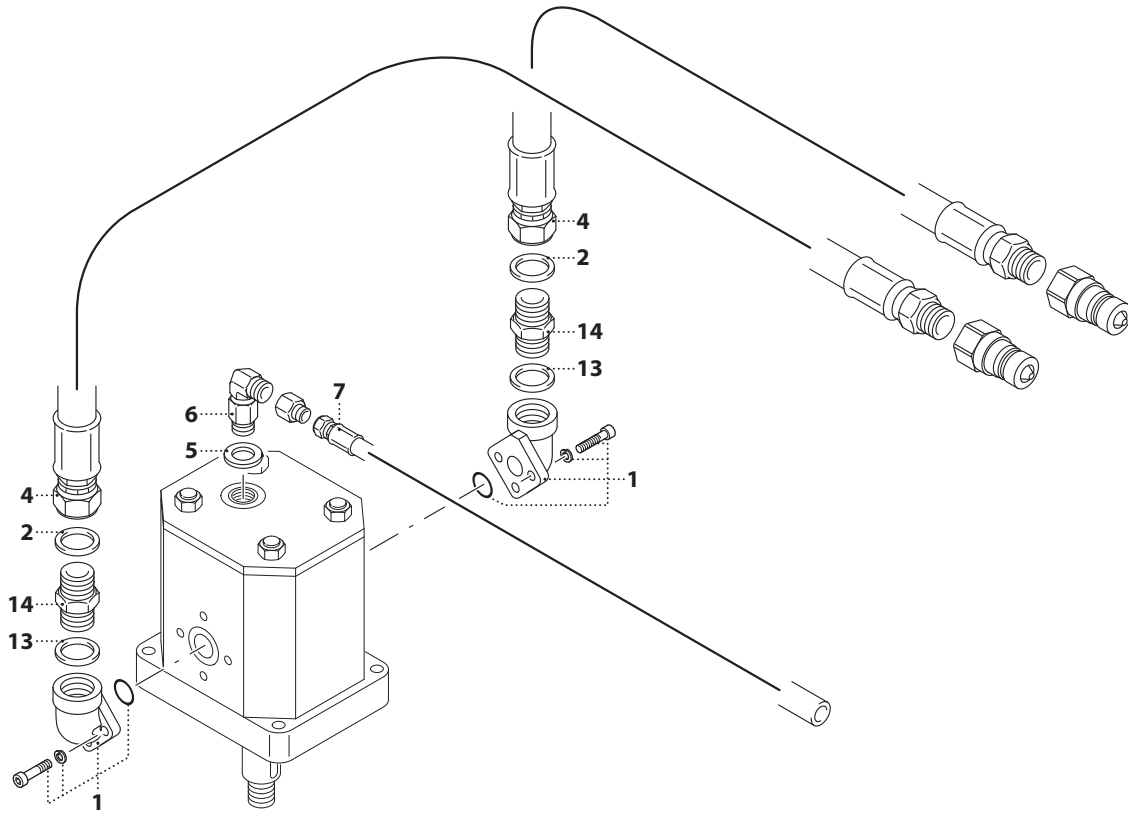

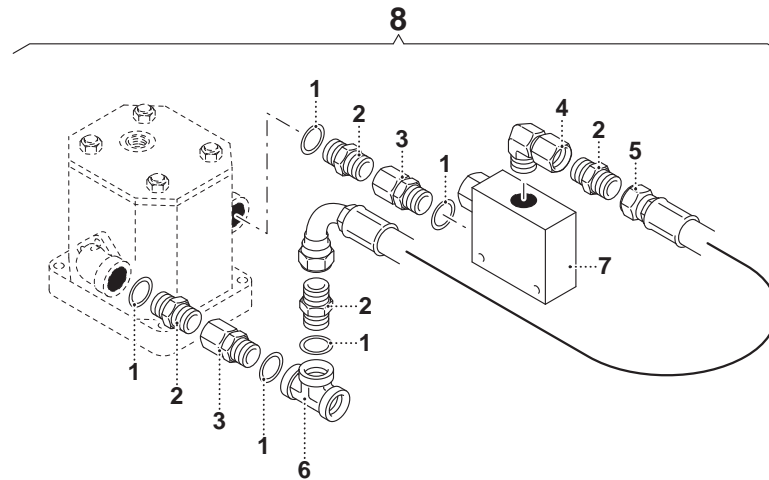

KIT VALVOLA PORTATA COMPENSATA (OPZIONALE) (36 cc)

*KIT VALVE DE PRIORITÉ (OPTION)
KIT AUSGLEICHVENTIL (ZUBEHÖR)
KIT FLOW SHUTTER VALVE (OPTIONAL)*

TAV. 4.4

**MRP1
120÷210 ID**

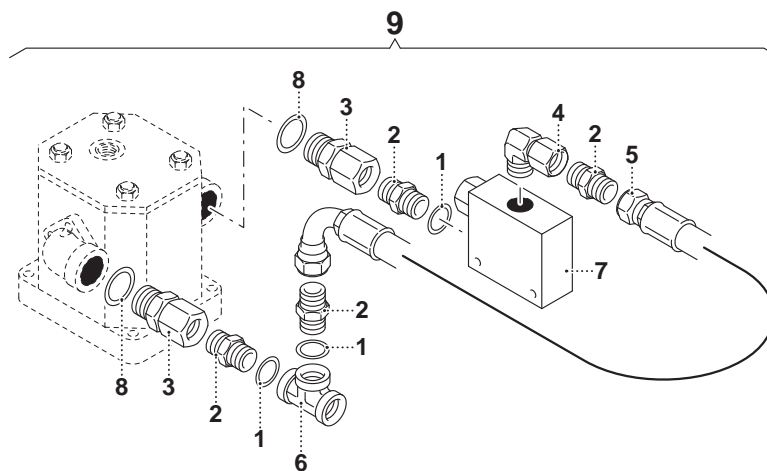

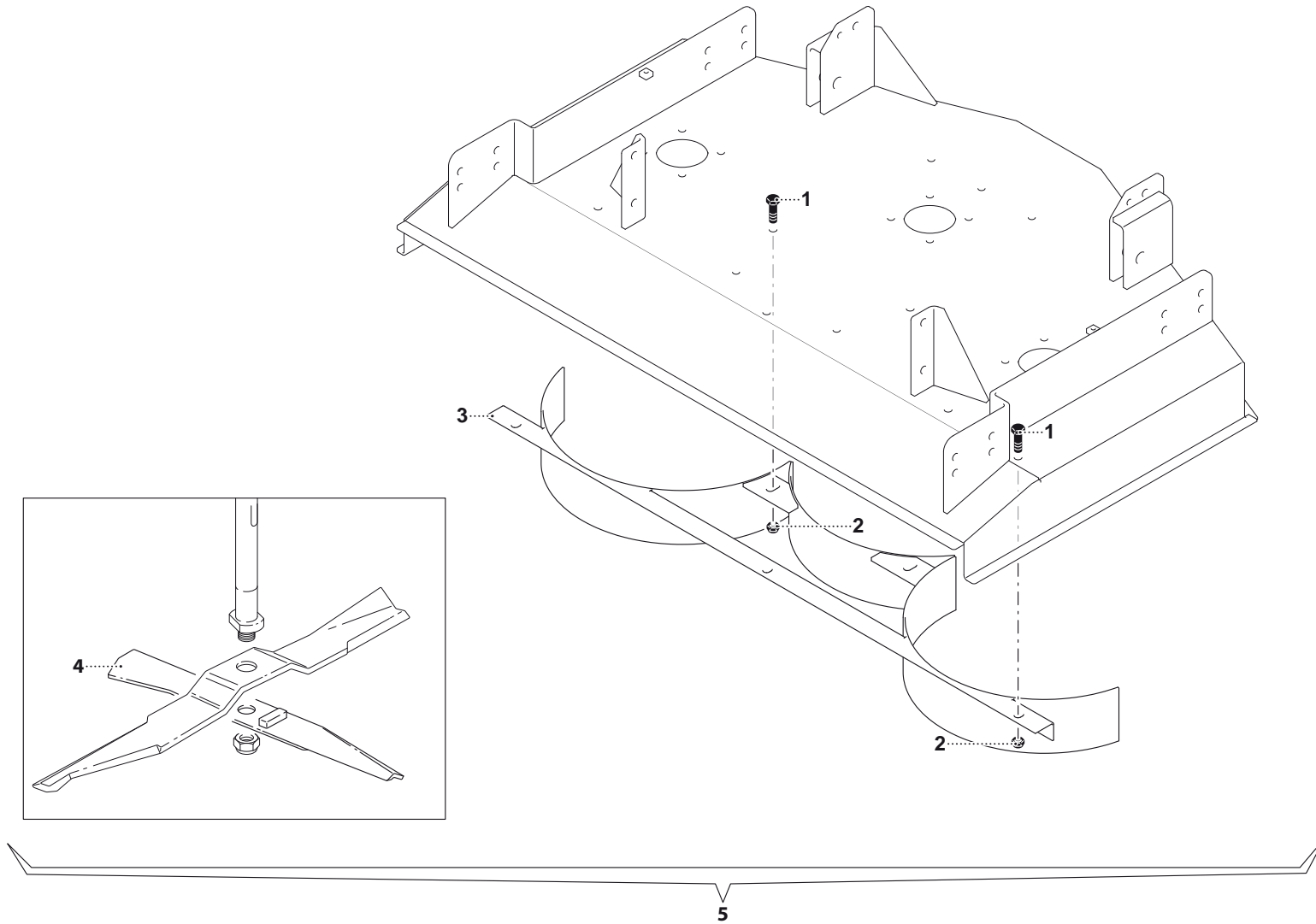



ATTACCO FRONTALE STANDARD
FRONTANBAU

ATELAGE FRONTAL
FRONT LINKAGE

TAV. 6.0

MRP1
120÷210 ID

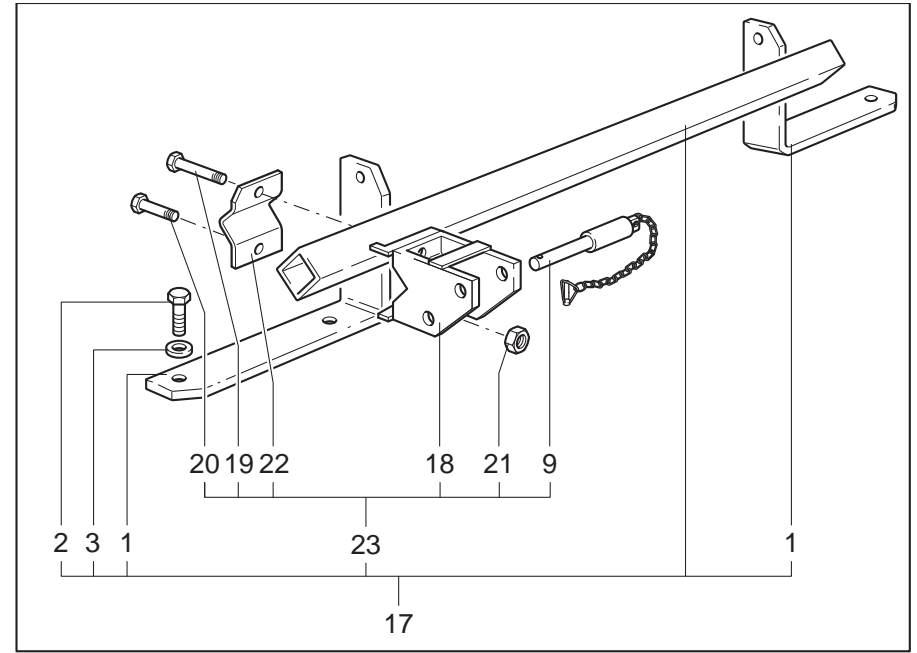
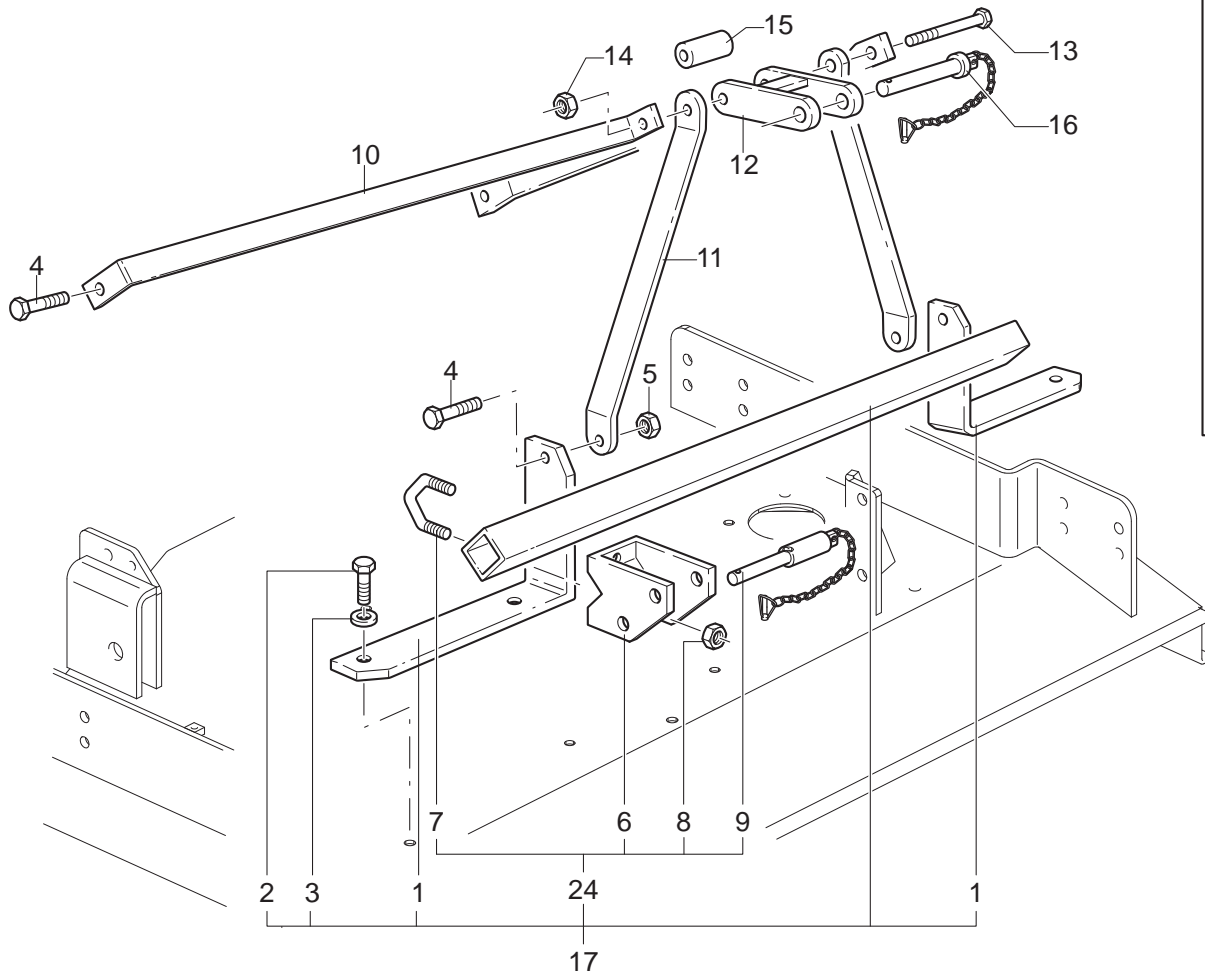

MURATORI MRP1 120÷210 ID
TAV. 6.0

POS.	N° CODICE	Q.	DESCRIZIONE	DESIGNATION	BENENNUNG	DESCRIPTION	DESIGNAZIONE	Da matr. De nr. serie Vom Seriennr. From serial nr.	Fino matr. Jusqu'au nr. serie Bis Seriennr. Up to serial nr.
1	40234400	1	STAFFA	BRIDE	BÜGEL	BRACKET	120-135		
1	40234500	1	STAFFA	BRIDE	BÜGEL	BRACKET	150-180-210		
2	60023500		VITE	VIS	SCHRAUBE	SCREW	TE 10 x 35 UNI 5739 8.8 ZNT		
3	61004900		RONDELLA	RONDELLE	SCHEIBE	WASHER	PIANA Ø 10 UNI 6592		
4	60028200	4	VITE	VIS	SCHRAUBE	SCREW	TE 12 x 40 UNI 5739 8.8 ZNT		
5	62010600	4	DADO	ECROU	MUTTER	NUT	M 12 x 1.75 AUTOBLOCC.		
6	40262100	2	STAFFA	BRIDE	BÜGEL	BRACKET			115986
7	38022301	2	CAVALLOTTO	ARRETOIR	KLEMMSTÜCK	UBOLT			115986
8	62010600	4	DADO	ECROU	MUTTER	NUT	M 12 x 1.75 AUTOBLOCC.		115986
9	68062300	2	PERNO	PIVOT	BOLZEN	PIN			
10	30182800	2	TIRANTE	TIRANT	STANGE	TIEROD	120		
10	30205300	2	TIRANTE	TIRANT	STANGE	TIEROD	135		
10	30182900	2	TIRANTE	TIRANT	STANGE	TIEROD	150		
10	30183000	2	TIRANTE	TIRANT	STANGE	TIEROD	180		
10	30205400	2	TIRANTE	TIRANT	STANGE	TIEROD	210		
11	30178900	2	TIRANTE	TIRANT	STANGE	TIEROD			
12	40237800	1	ATTACCO	ATTACHE	ANSCHLUSS	ATTACHMENT			
13	60011900	1	VITE	VIS	SCHRAUBE	SCREW	TE 12 x 120 UNI 5737		
14	62010600	1	DADO	ECROU	MUTTER	NUT	M 12 x 1.75 AUTOBLOCC.		
15	32021400	1	DISTANZIALE	ENTRETOISE	DISTANZSTÜCK	SPACER			
16	38024100	2	PERNO	PIVOT	BOLZEN	PIN			
17	45113300		KIT ATTACCO FRONTALE	KIT ATTELAGE FRONTAL	FRONTANBAUSATZ	FRONT LINKAGE KIT	120-135		
17	45113400		KIT ATTACCO FRONTALE	KIT ATTELAGE FRONTAL	FRONTANBAUSATZ	FRONT LINKAGE KIT	150-180-210		
18	40262101	2	STAFFA	BRIDE	BÜGEL	BRACKET		115987	
19	60010100	2	VITE	VIS	SCHRAUBE	SCREW	TE 12x65 UNI 5737	115987	
20	60045400	2	VITE	VIS	SCHRAUBE	SCREW	TE 12x55 UNI 5737	115987	



ATTACCO FRONTALE STANDARD
FRONTANBAU

ATELAGE FRONTAL
FRONT LINKAGE

TAV. 6.0

MRP1
120÷210 ID

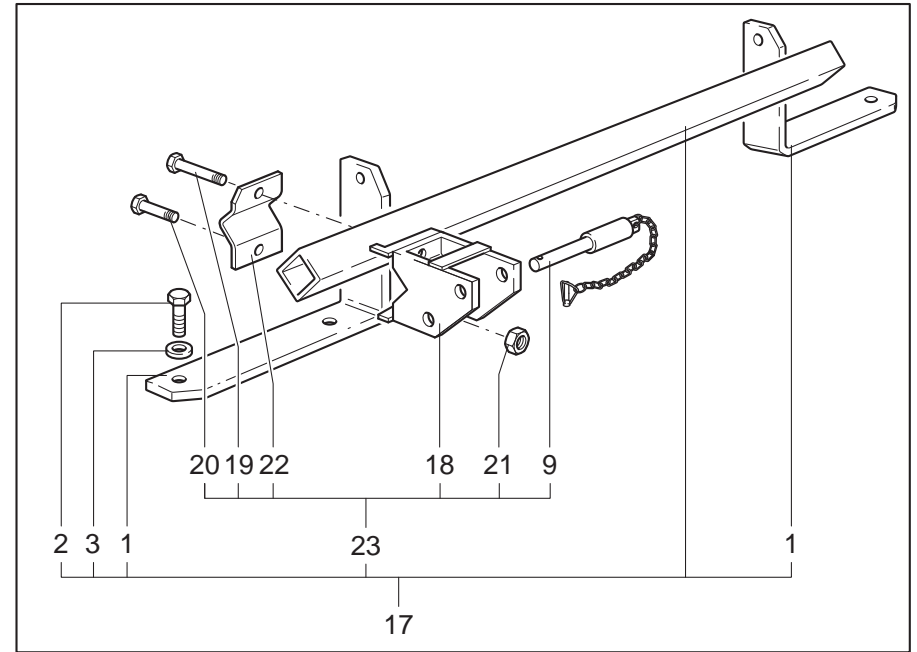
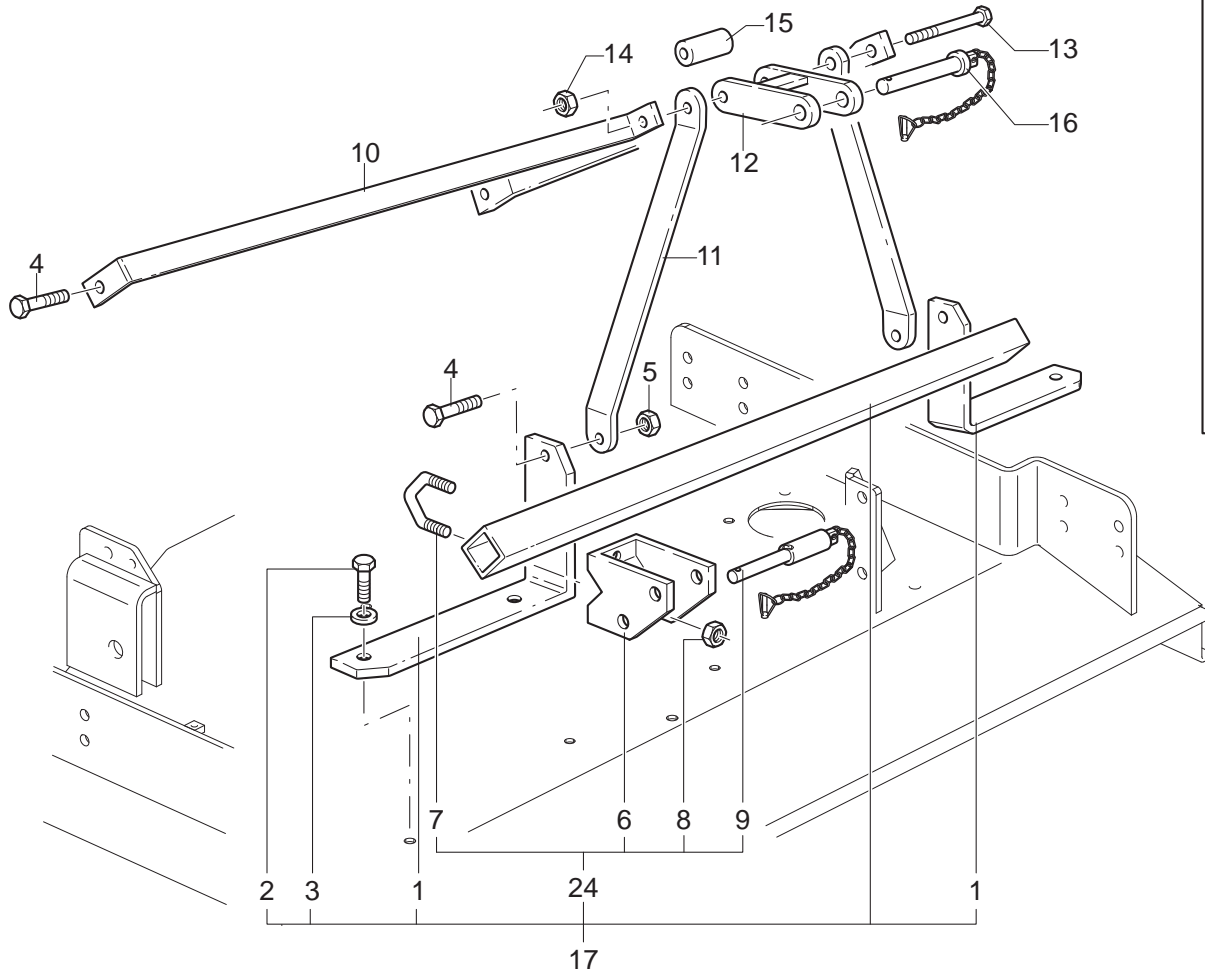

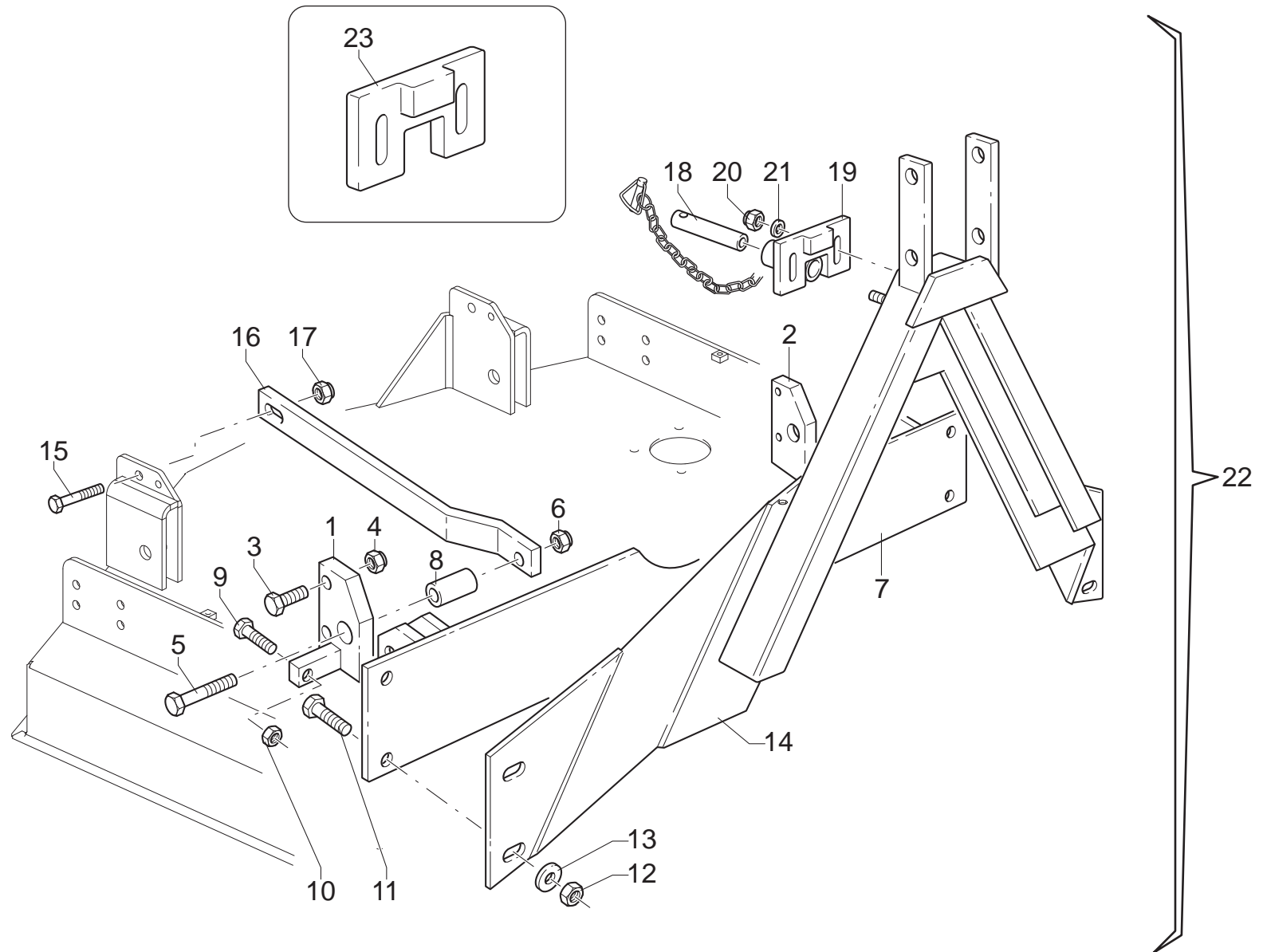

MURATORI MRP1 120÷210 ID

TAV. 7.0

POS.	N° CODICE	Q.	DESCRIZIONE	DESIGNATION	BENENNUNG	DESCRIPTION	DESIGNAZIONE	Da matr. De nr. serie Vom Seriennr. From serial nr.	Fino matr. Jusqu'au nr. serie Bis Seriennr. Up to serial nr.
1	40238200	1	STAFFA DX	BRIDE (D)	BÜGEL (RECHTS)	BRACKET (RH)			
2	40238100	1	STAFFA SX	BRIDE (G)	BÜGEL (LINKS)	BRACKET (LH)			
3	60028100	4	VITE	VIS	SCHRAUBE	SCREW	TE 12 x 55 UNI 5739		
4	62010600	4	DADO	ECROU	MUTTER	NUT	M 12 x 1.75 AUTOBLOCC.		
5	60014300	2	VITE	VIS	SCHRAUBE	SCREW	TE 16 x 65 UNI 5737		
6	62008900	2	DADO	ECROU	MUTTER	NUT	M 16 x 2 UNI 5588		
7	40238300	1	STAFFA	BRIDE	BÜGEL	BRACKET			
8	32167400	2	DISTANZIALE	ENTRETOISE	DISTANZSTÜCK	SPACER			
9	60042400	2	VITE	VIS	SCHRAUBE	SCREW	TE 16 x 45 UNI 5739		
10	62011000	2	DADO	ECROU	MUTTER	NUT	M 16 x 2 AUTOBLOCC.		
11	60023000	4	VITE	VIS	SCHRAUBE	SCREW	TE 12 x 30 UNI 5739 8.8 ZNT		
12	62010600	4	DADO	ECROU	MUTTER	NUT	M 12 x 1.75 AUTOBLOCC.		
13	61005000	4	RONDELLA	RONDELLE	SCHEIBE	WASHER	Ø 12 PIANA UNI 6592		
14	40308900	1	ATTACCO	ATTACHE	ANSCHLUSS	ATTACHMENT			
15	60021200	2	VITE	VIS	SCHRAUBE	SCREW	TE 12 x 35 UNI 5739 8.8 ZNT		
16	30191300	2	TIRANTE	TIRANT	STANGE	TIEROD	120		
16	30205500	2	TIRANTE	TIRANT	STANGE	TIEROD	135		
16	30191400	2	TIRANTE	TIRANT	STANGE	TIEROD	150		
16	30191500	2	TIRANTE	TIRANT	STANGE	TIEROD	180		
16	30205600	2	TIRANTE	TIRANT	STANGE	TIEROD	210		
17	62010600	2	DADO	ECROU	MUTTER	NUT	M 12 x 1.75 AUTOBLOCC.		
18	68087100	1	PERNO	PIVOT	BOLZEN	PIN			
19	40246700	1	BLOCCAGGIO	BLOCAGE	BEFESTIGUNG	LOCK			
20	62010200	2	DADO	ECROU	MUTTER	NUT	M 8 x 1.25 AUTOBLOCC.		
21	61004700	2	RONDELLA	RONDELLE	SCHEIBE	WASHER	Ø 8 PIANA UNI 6592		
22	45119200		KIT ATTACCO FRONTALE	KIT ATTELAGE FRONTAL	FRONTANBAUSATZ	FRONT LINKAGE KIT	120		

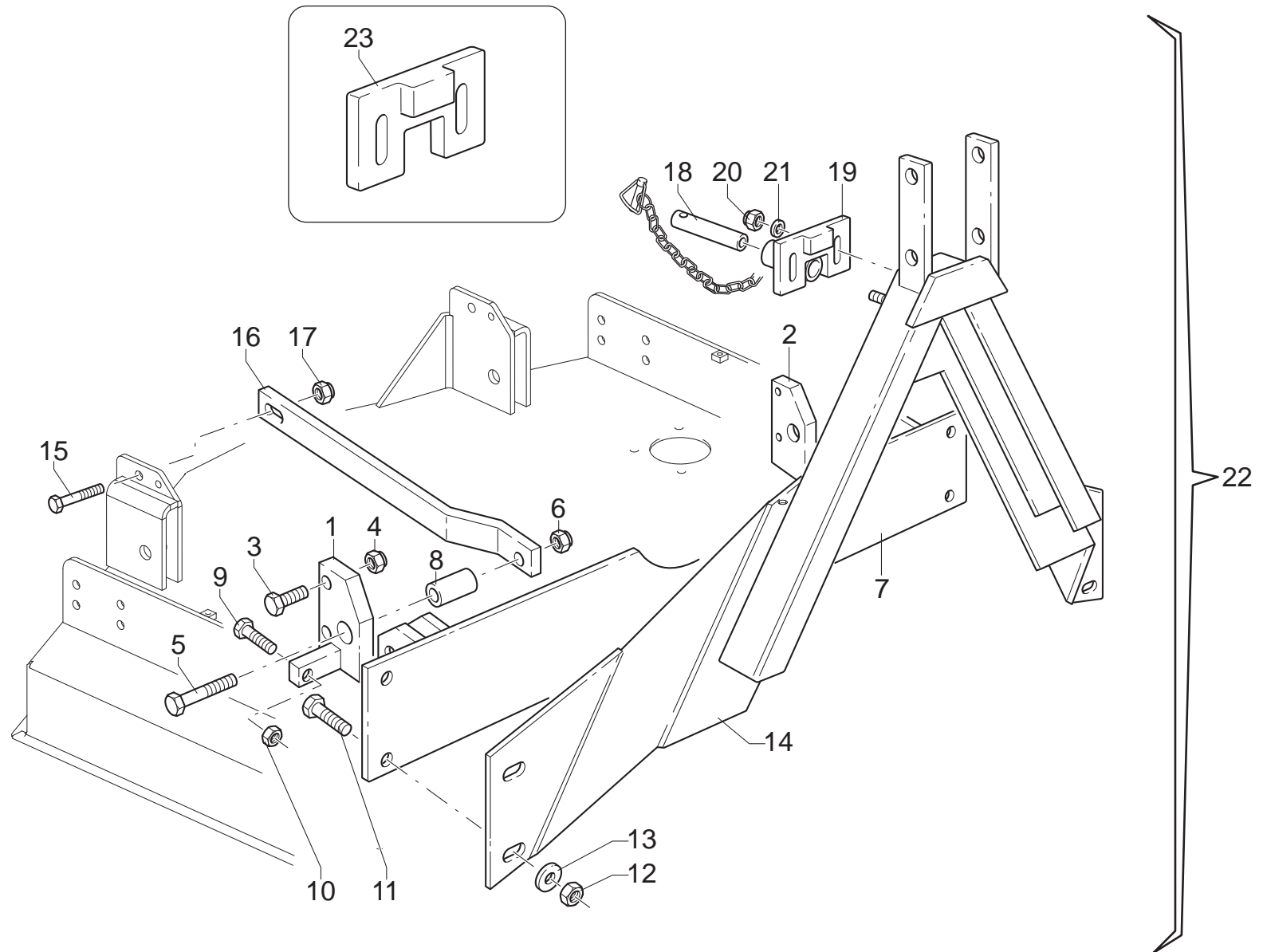

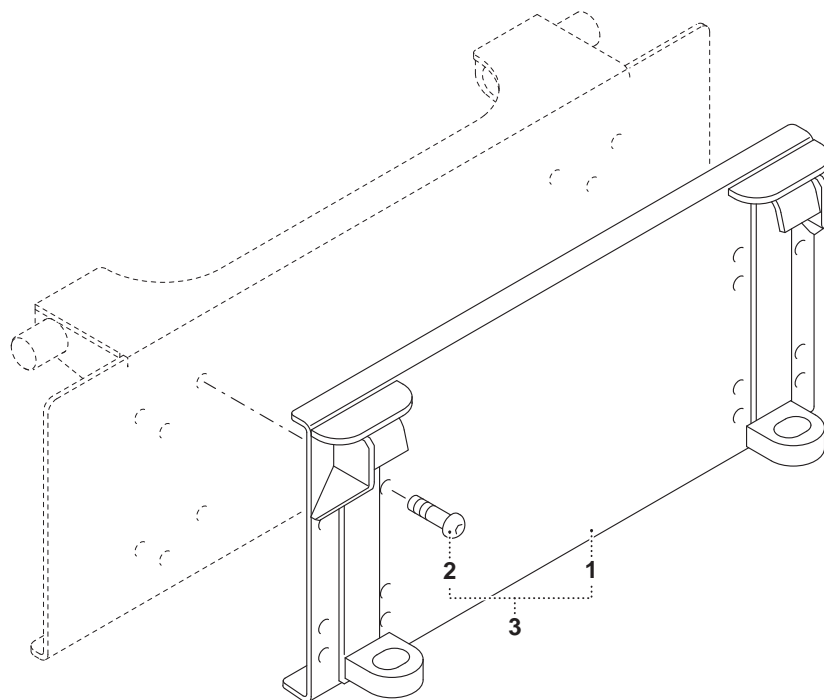

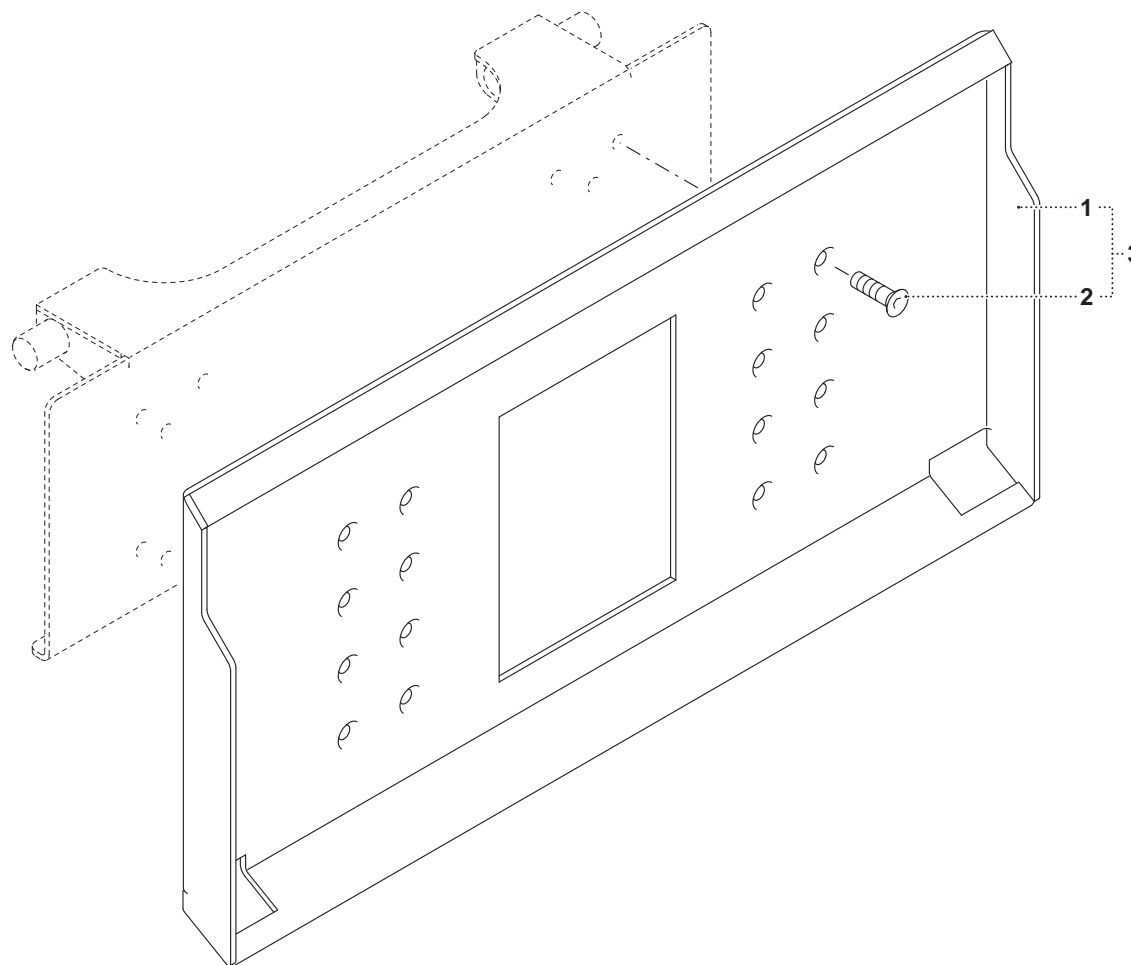

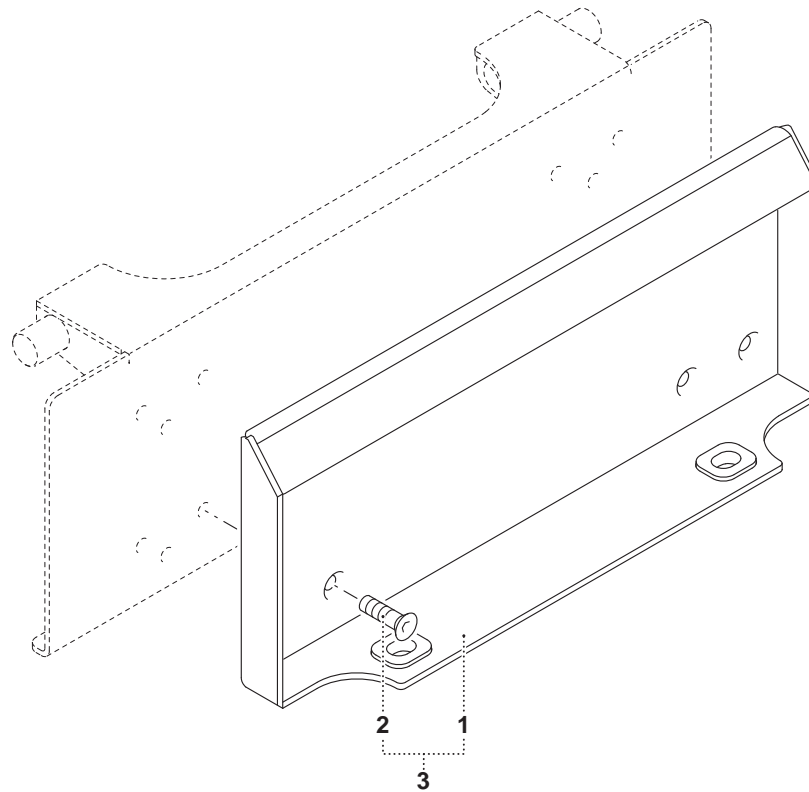

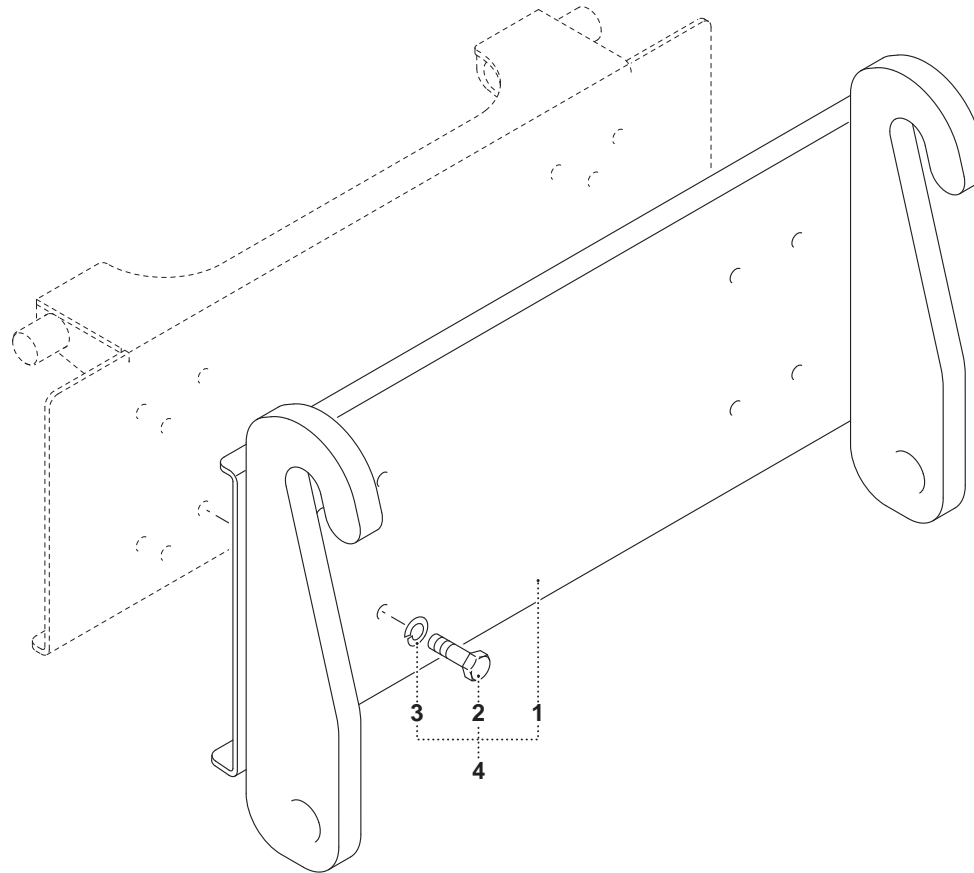

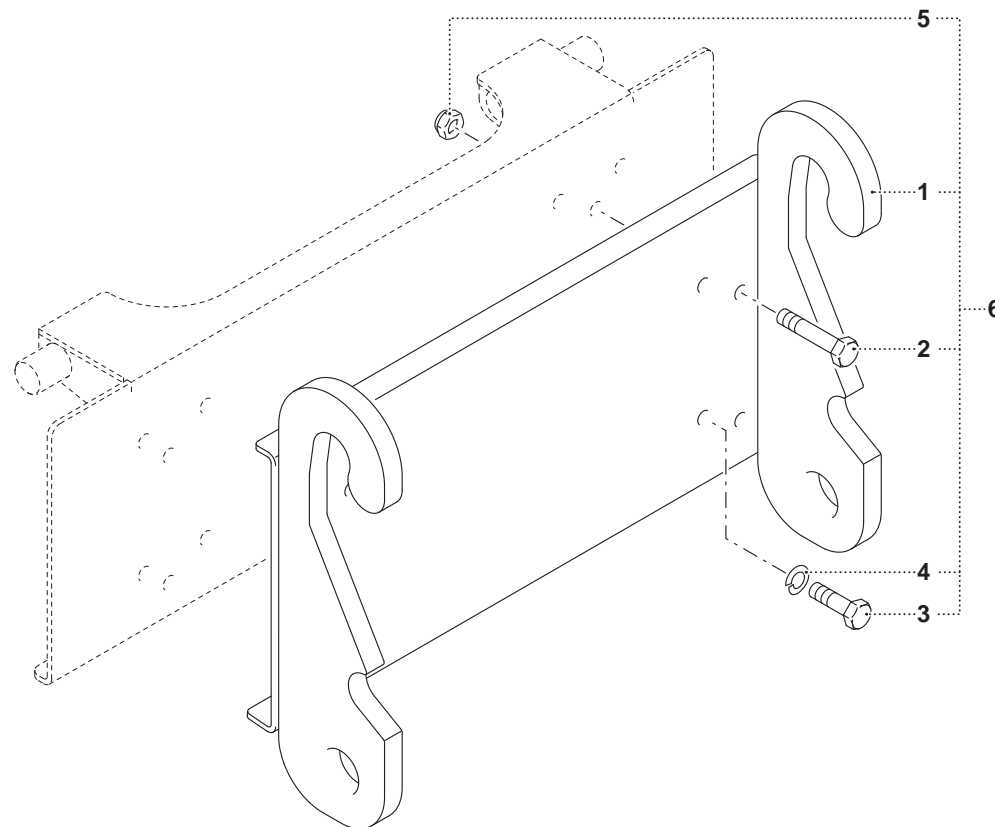

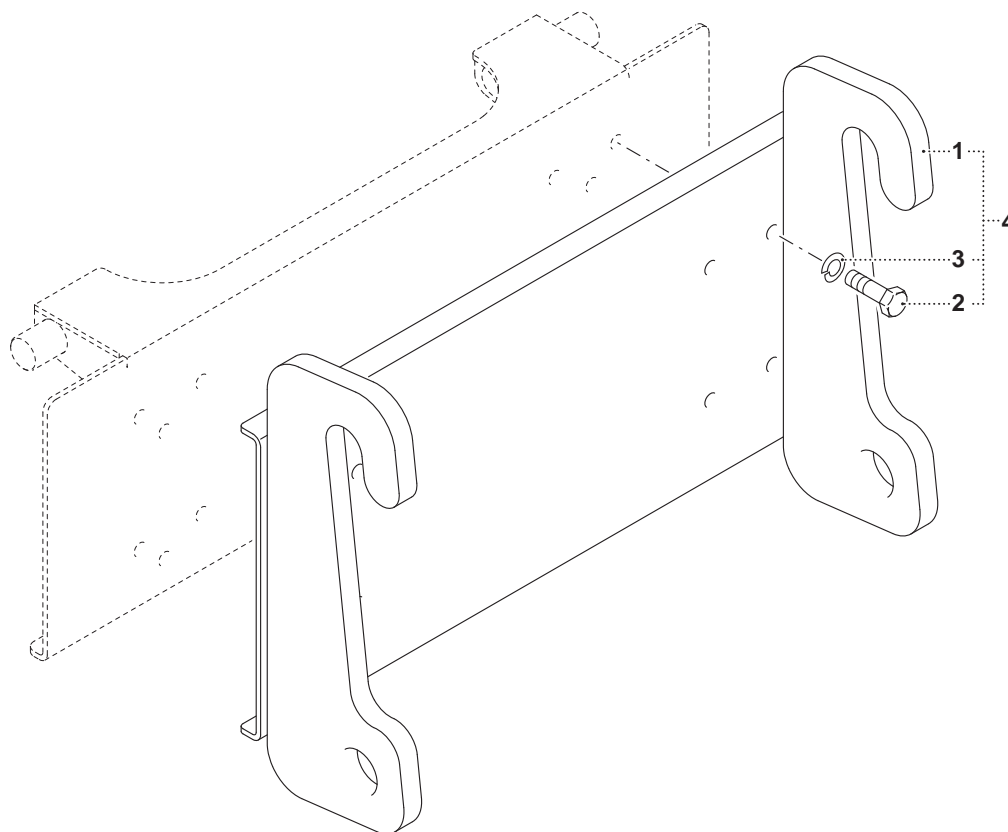

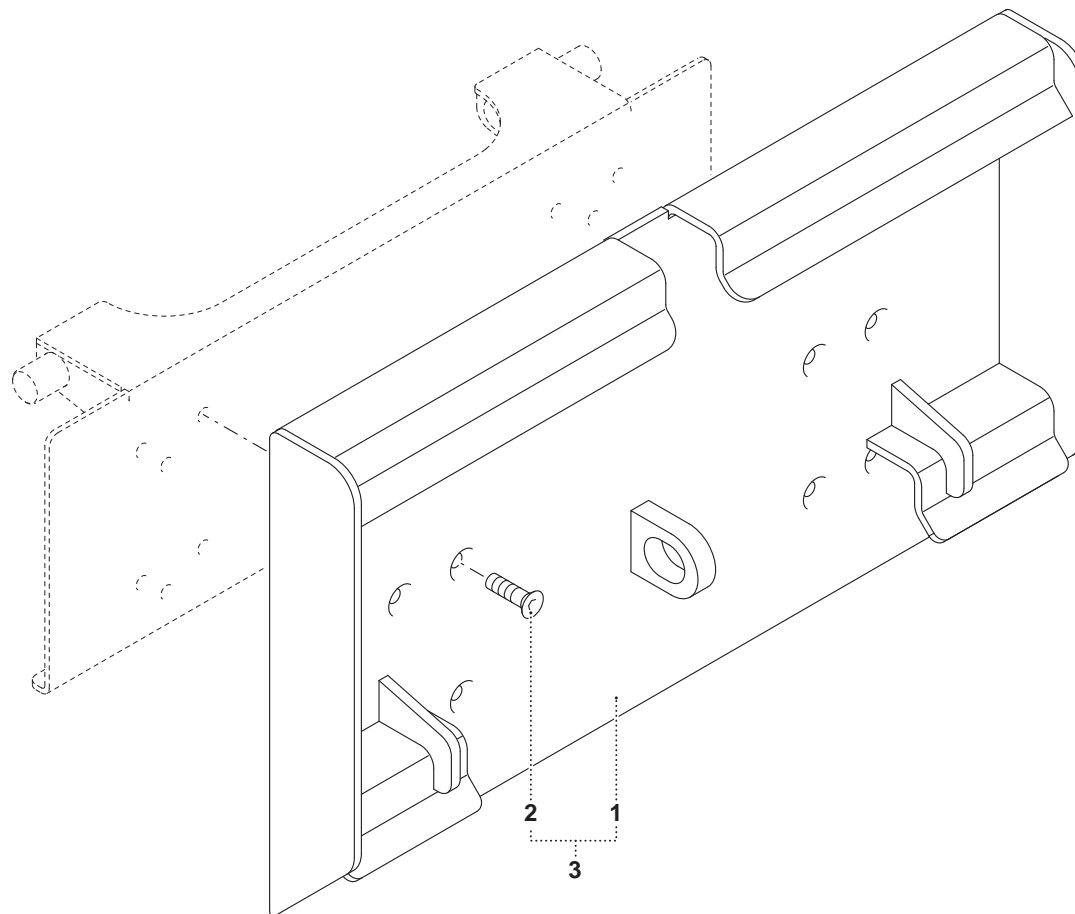

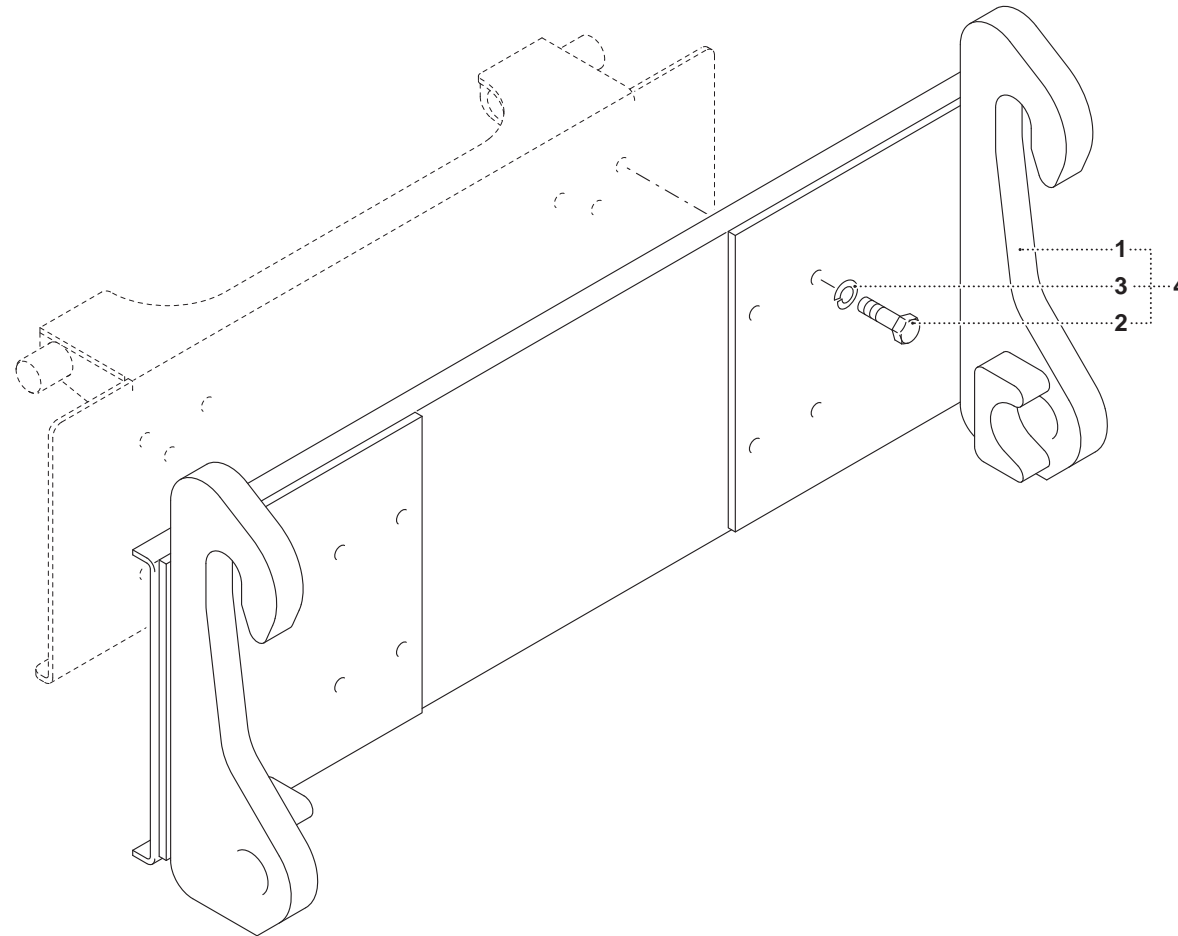

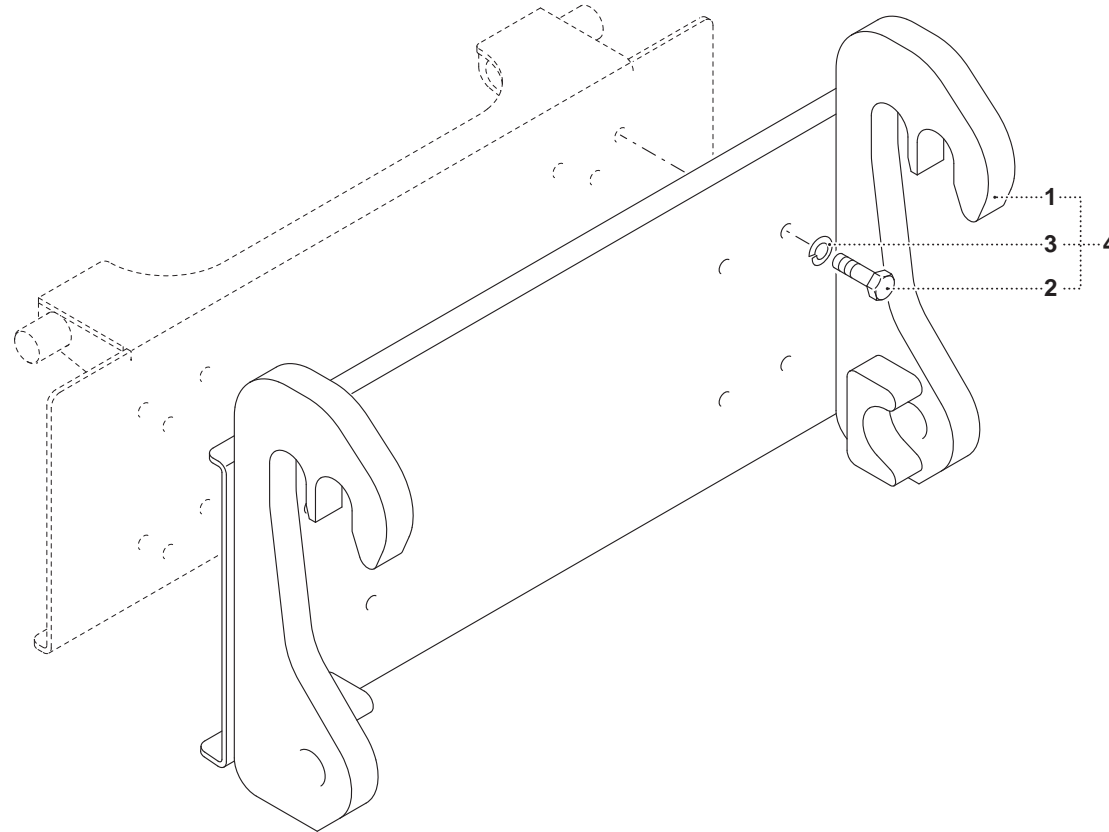

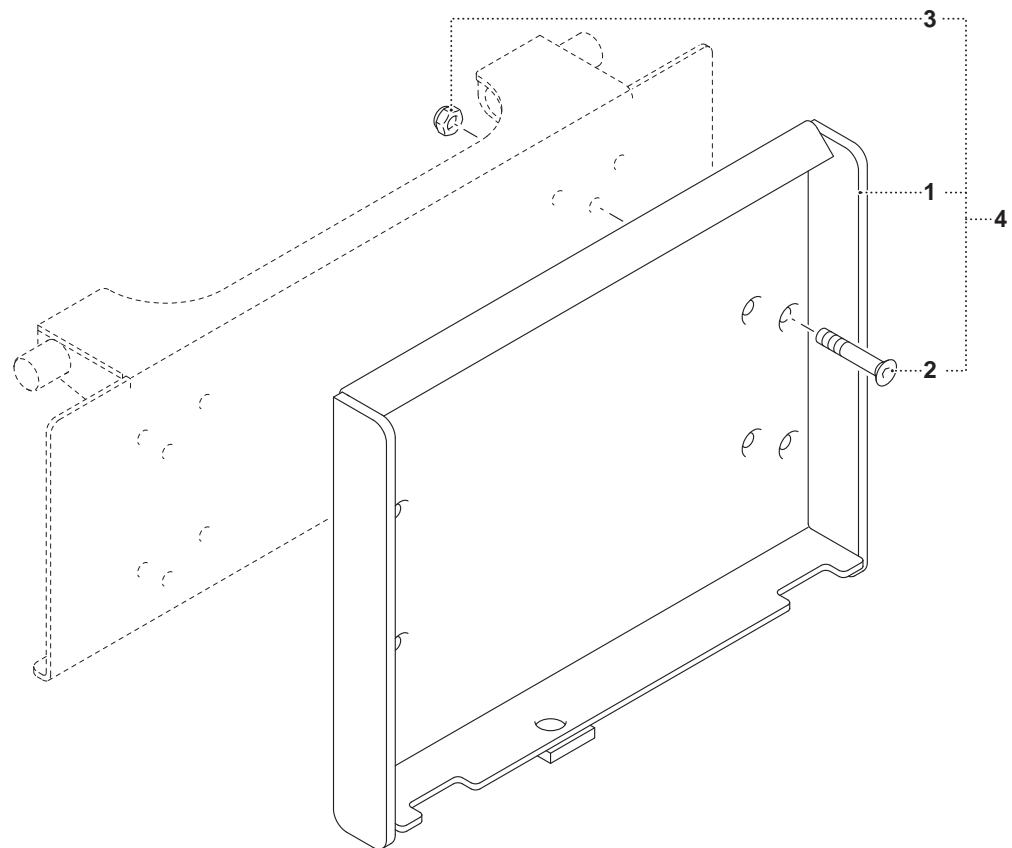

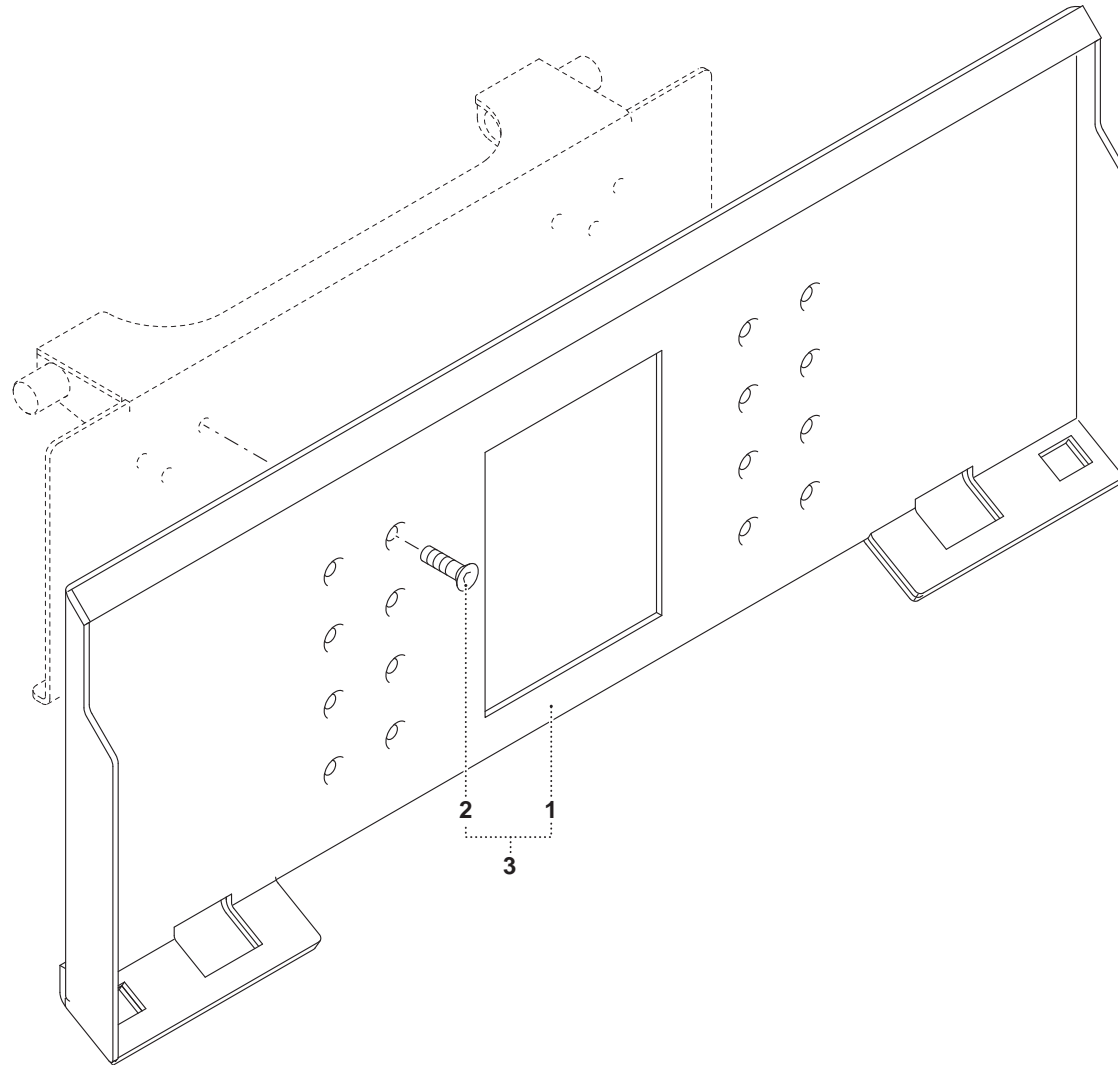



INGRASSATORI ESTERNI
SAMMELSCHMIERUNG

GRAISSAGE CENTRALISE
GREASE EXTENSIONS

TAV. 8.0

MRP1
120÷210 ID

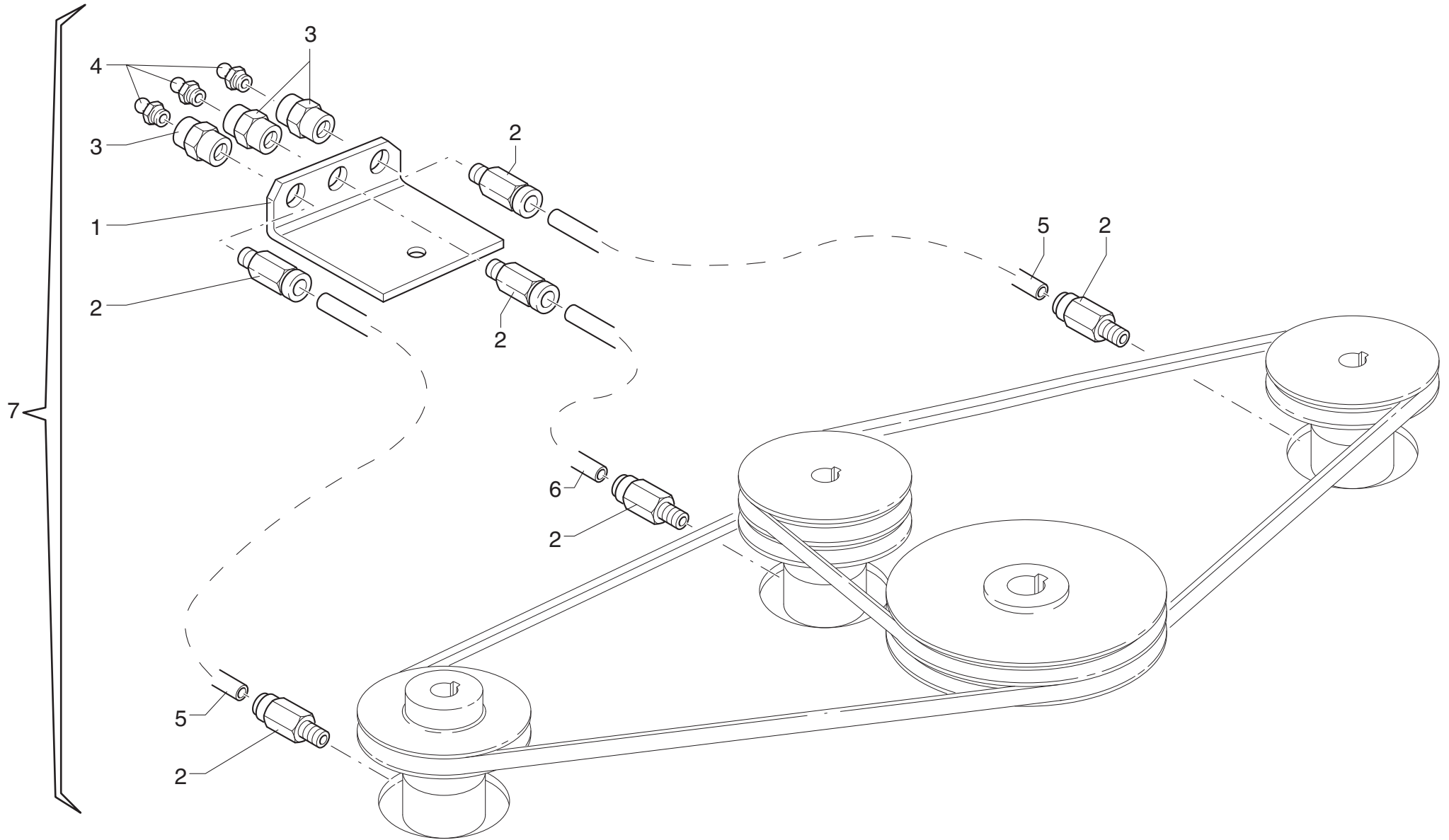

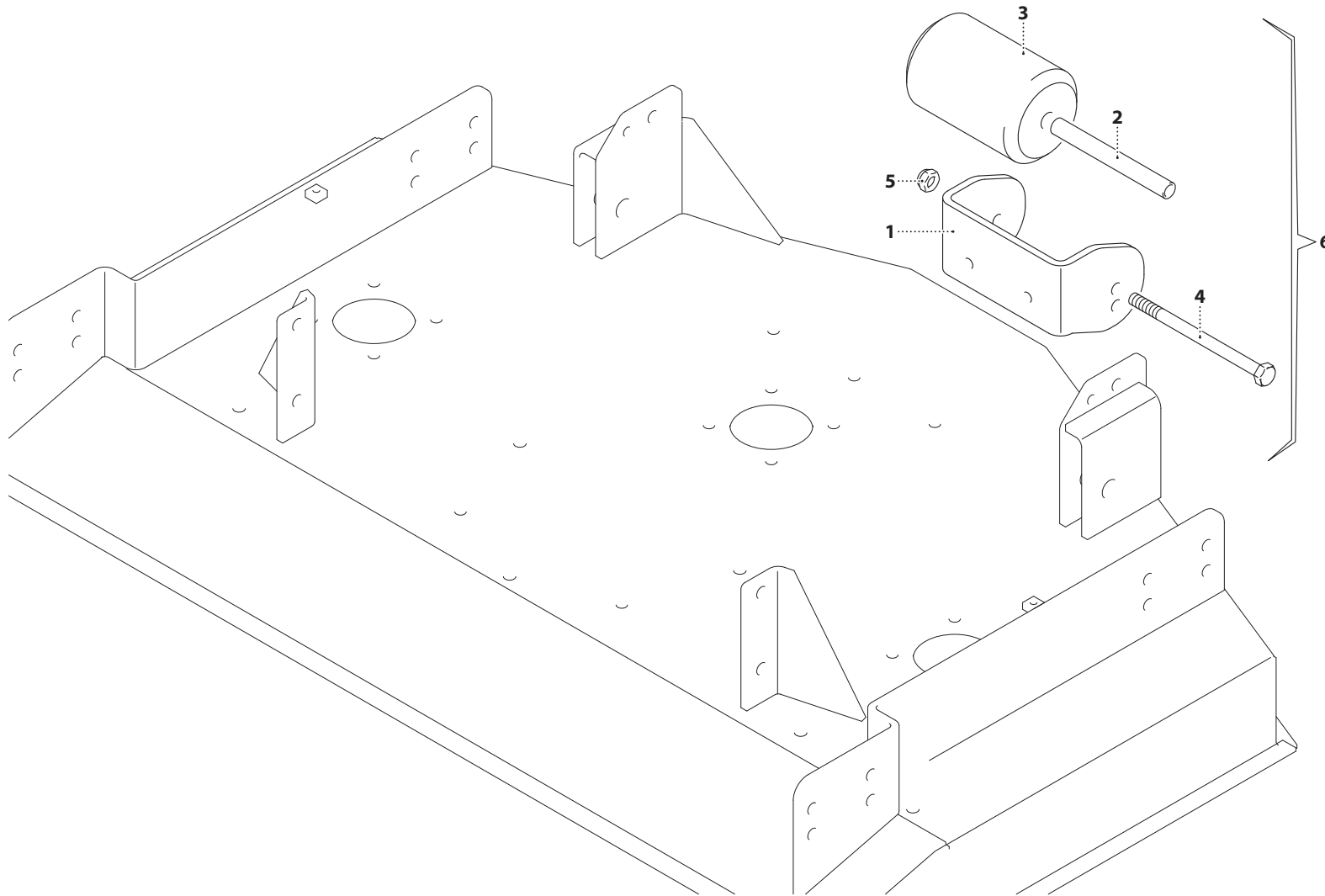

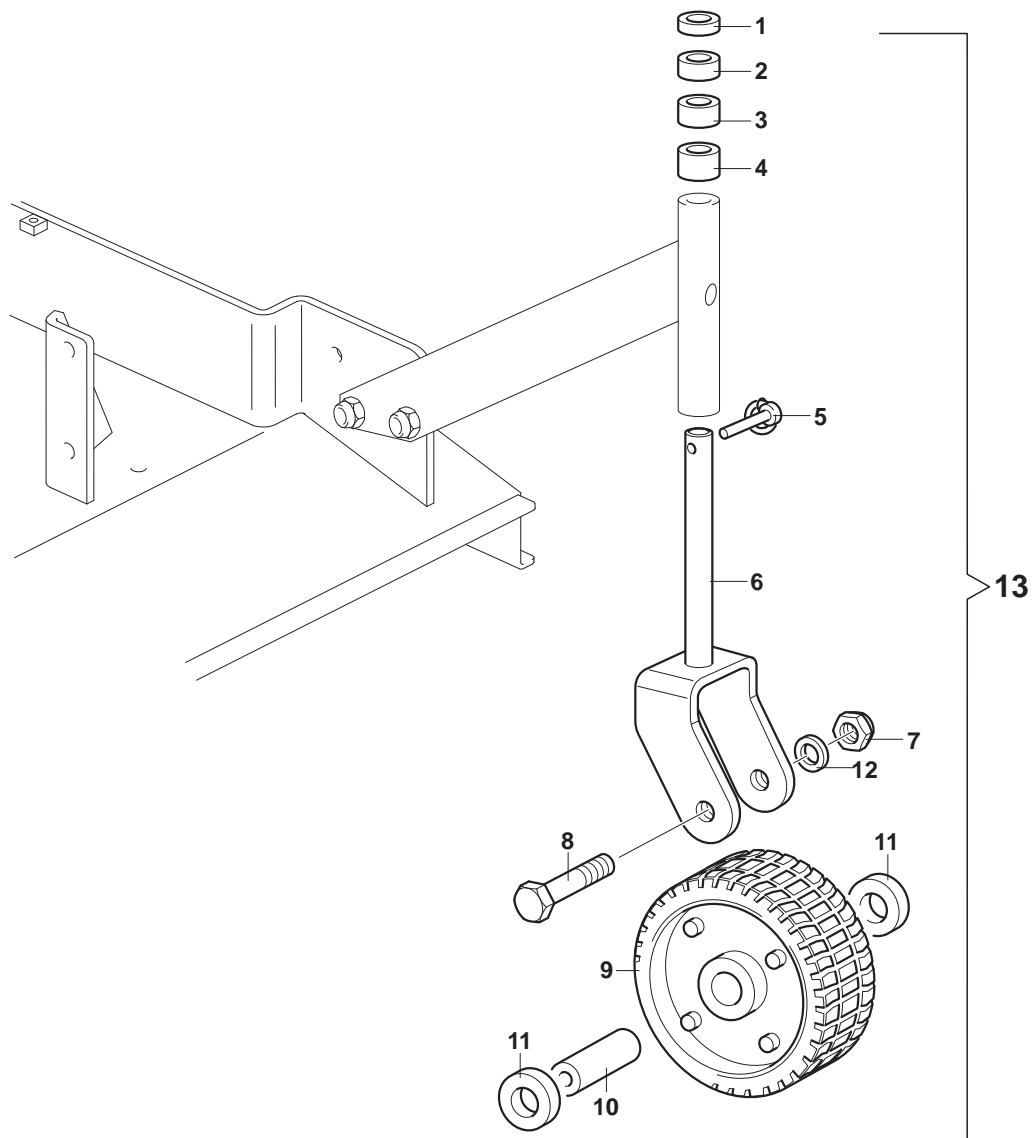

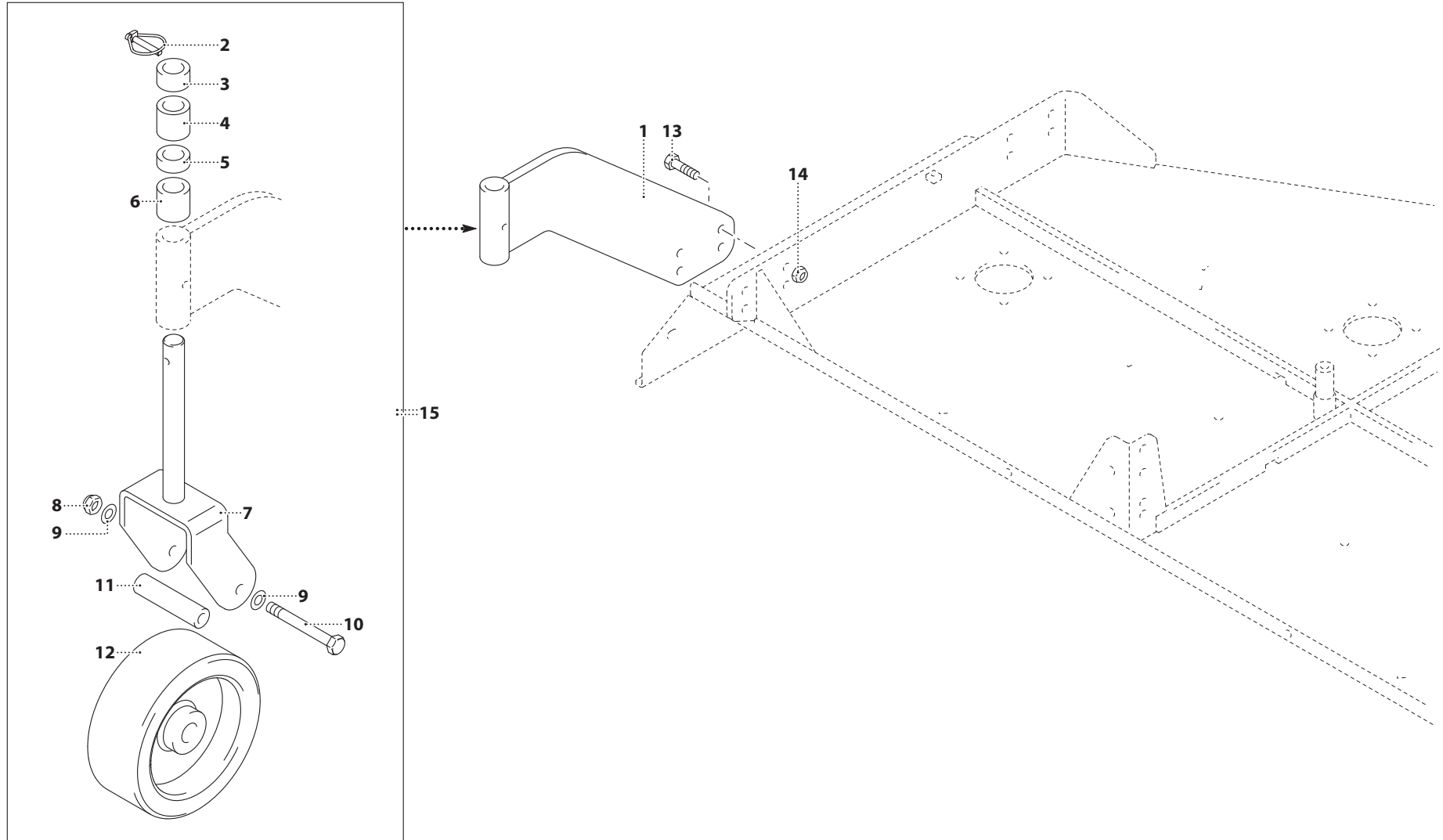

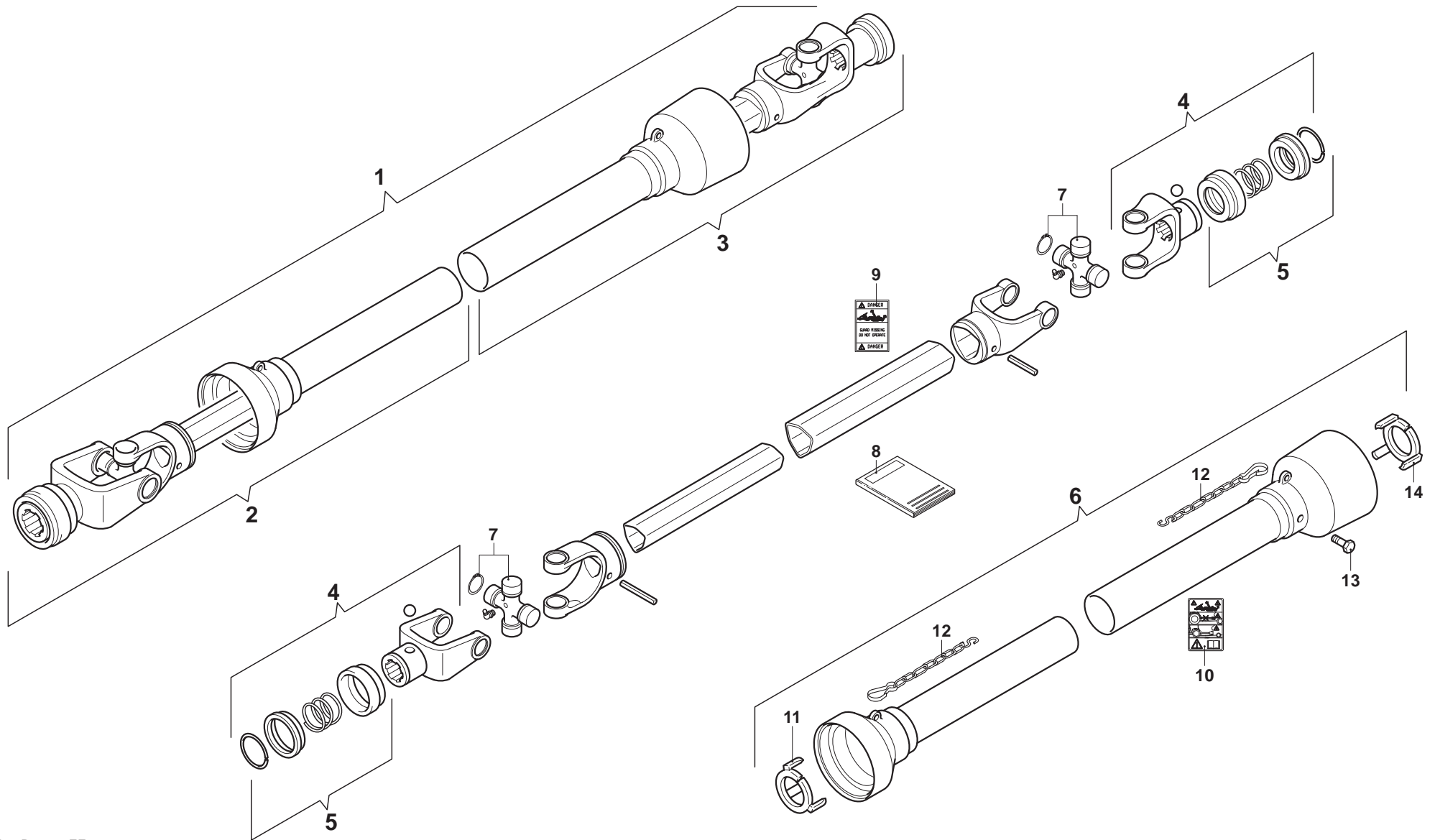

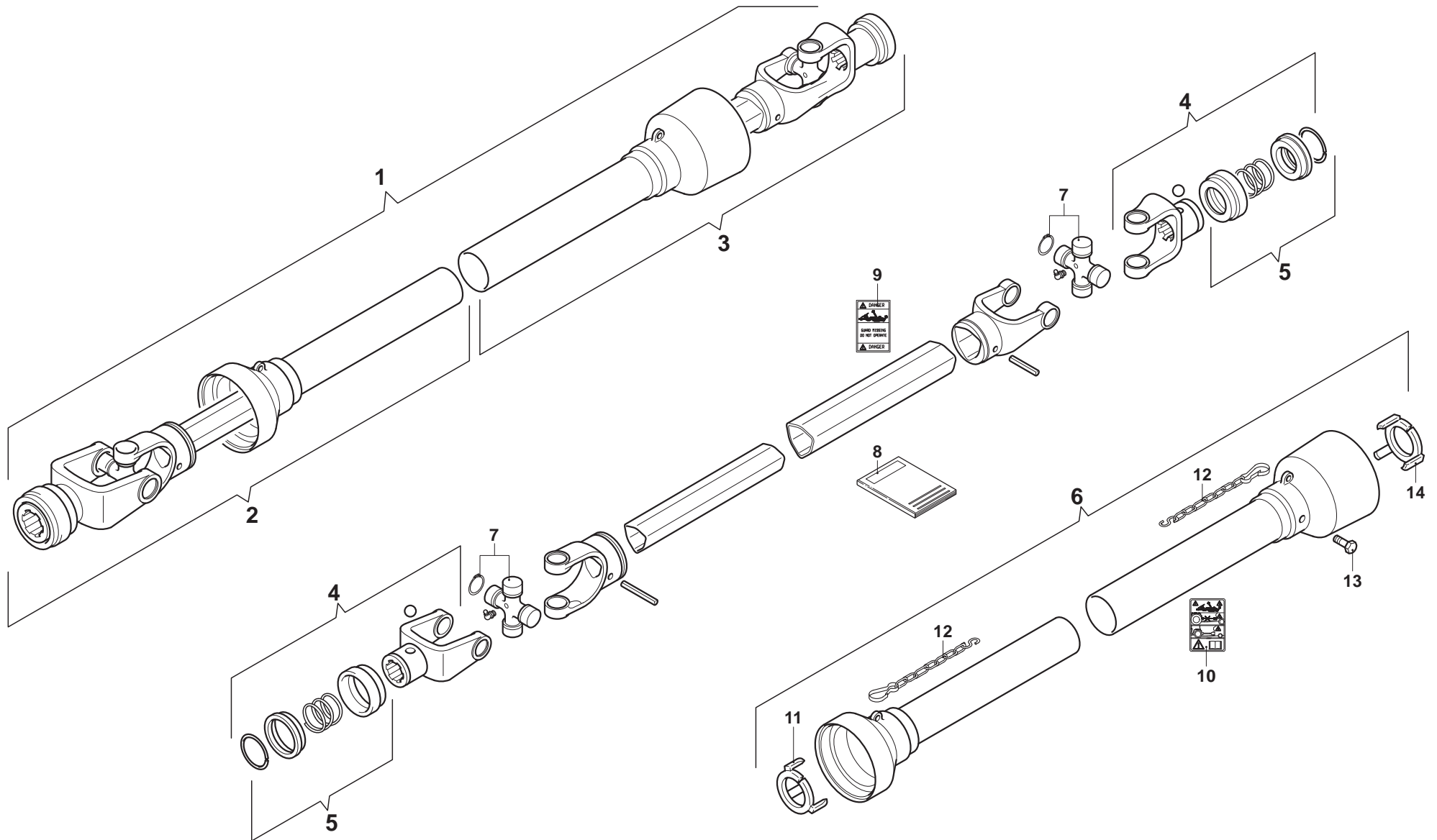

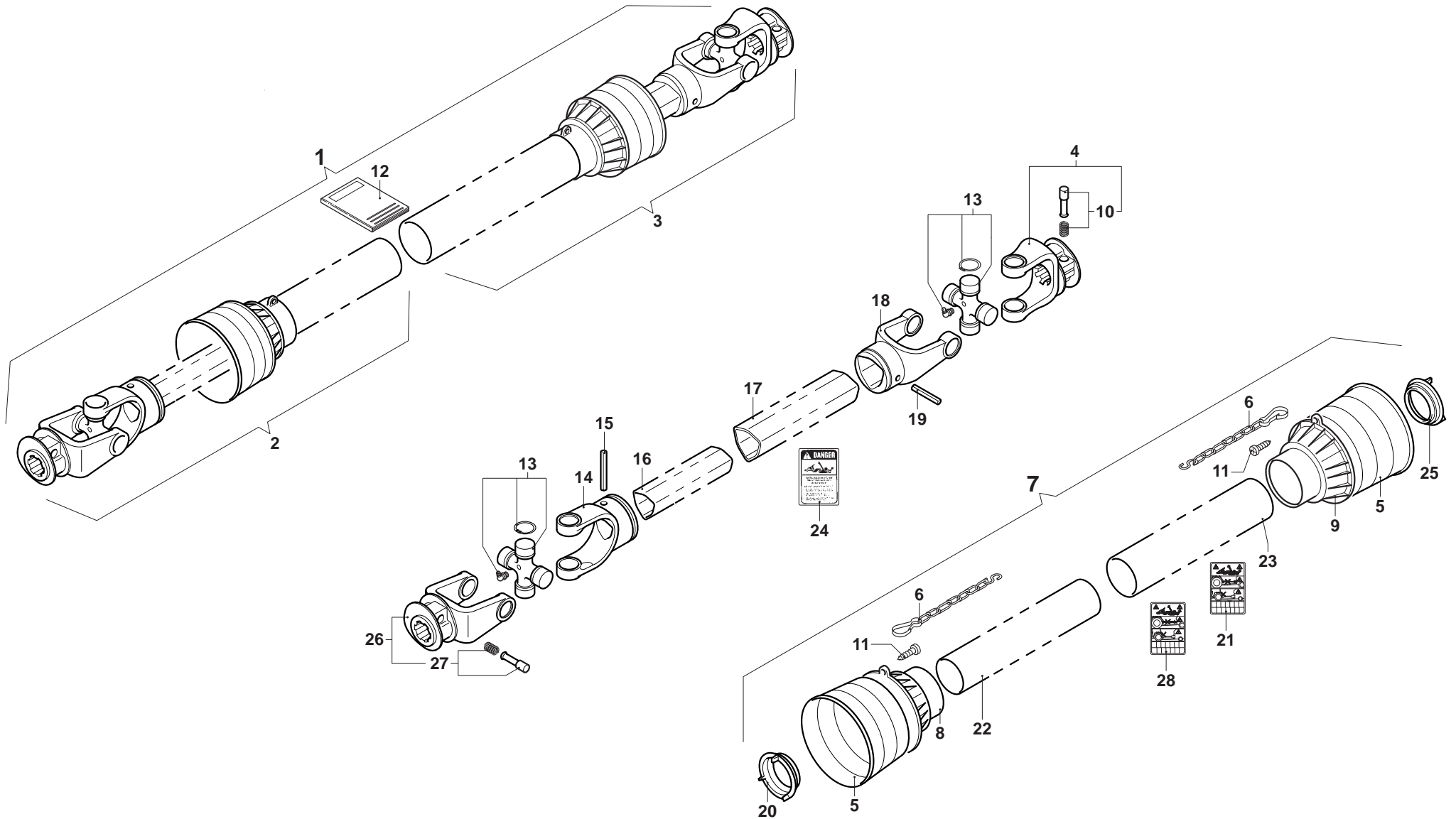

MURATORI MRP1 120÷210 ID

TAV. 13.0

POS.	N° CODICE	Q.	DESCRIZIONE	DESIGNATION	BENENNUNG	DESCRIPTION	DESIGNAZIONE	Da matr. De nr. serie Vom Seriennr. From serial nr.	Fino matr. Jusqu'au nr. serie Bis Seriennr. Up to serial nr.
1	AB210SFD0	1	ALBERO CARDANICO COMPLETO	ARBRE A JOINTS DE CARDAN	KARDANWELLE	PTO SHAFT			
2	B2N081CE1001	1	SEMIALBERO INTERNO	DEMI-ARBRE INTERIEUR	INNENHALBWELLE	INTERNAL HALF SHAFT			
3	B2N081CE2001	1	SEMIALBERO ESTERNO	DEMI-ARBRE EXTERIEUR	AUSSENHALBWELLE	EXTERNAL HALF SHAFT			
4	0800203	1	FORCELLA	FOURCHE	GABEL	YOKE			
5	021902C001	2	CUFFIA	CAPOUCHON	HAUBE	GUARD			
6	0252000001	2	CATENA	CHAINE	KETTE	CHAIN			
7	083CE02051	1	PROTEZIONE	PROTECTION	SCHUTZ	GUARD			
8	025402C002	1	PROTEZIONE INTERNA	PROTECTION INTERIEURE	INNENSCHUTZ	INTERNAL GUARD			
9	025402C001	1	PROTEZIONE ESTERNA	PROTECTION EXTERIEURE		AUSSENSCHUTZ	EXTERNAL GUARD		
10	0986014047	1	PULSANTE	BOUTON	DRUCKKNOPF	PUSH BOTTON			
11	0998052242	6	VITE	VIS	SCHRAUBE	SCREW			
12	09872101	1	MANUALE ISTRUZIONI	MANUEL D'UTILISATION ET D'ENTRETIEN	BETRIEBS- UND WARTUNGSANLEITUNG	USE AND MAINTENANCE MANUAL			
13	08202	2	CROCIERA	CROISILLON	KREUZSTÜCK	SPIDER			
14	08002011	1	FORCELLA	FOURCHE	GABEL	YOKE			
15	098700850	1	SPINA ELASTICA	GOUPILLE ELASTIQUE	SPANNSTIFT	ELASTIC PIN			
16	09881294100	1	TUBO INTERNO	TUBE INTERIEUR	INNENROHR	INTERNAL TUBE			
17	09881363100	1	TUBO ESTERNO	TUBE EXTERIEUR	AUSSENROHR	EXTERNAL TUBE			
18	08002021	1	FORCELLA	FOURCHE	GABEL	YOKE			
19	098700855	1	SPINA ELASTICA	GOUPILLE ELASTIQUE	SPANNSTIFT	ELASTIC PIN			
20	025502C002	1	GHIERA	FRETTE	NUTMUTTER	RING NUT			
21	09872010	1	ETICHETTA	ETIQUETE	ETIKETT	LABEL			
22	0988955NB081	1	TUBO INTERNO	TUBE INTERIEUR	INNENROHR	INTERNAL TUBE			
23	0988961NB081	1	TUBO ESTERNO	TUBE EXTERIEUR	AUSSENROHR	EXTERNAL TUBE			
24	09872006	1	ETICHETTA	ETIQUETE	ETIKETT	LABEL			
25	025502C001	1	GHIERA	FRETTE	NUTMUTTER	RING NUT			

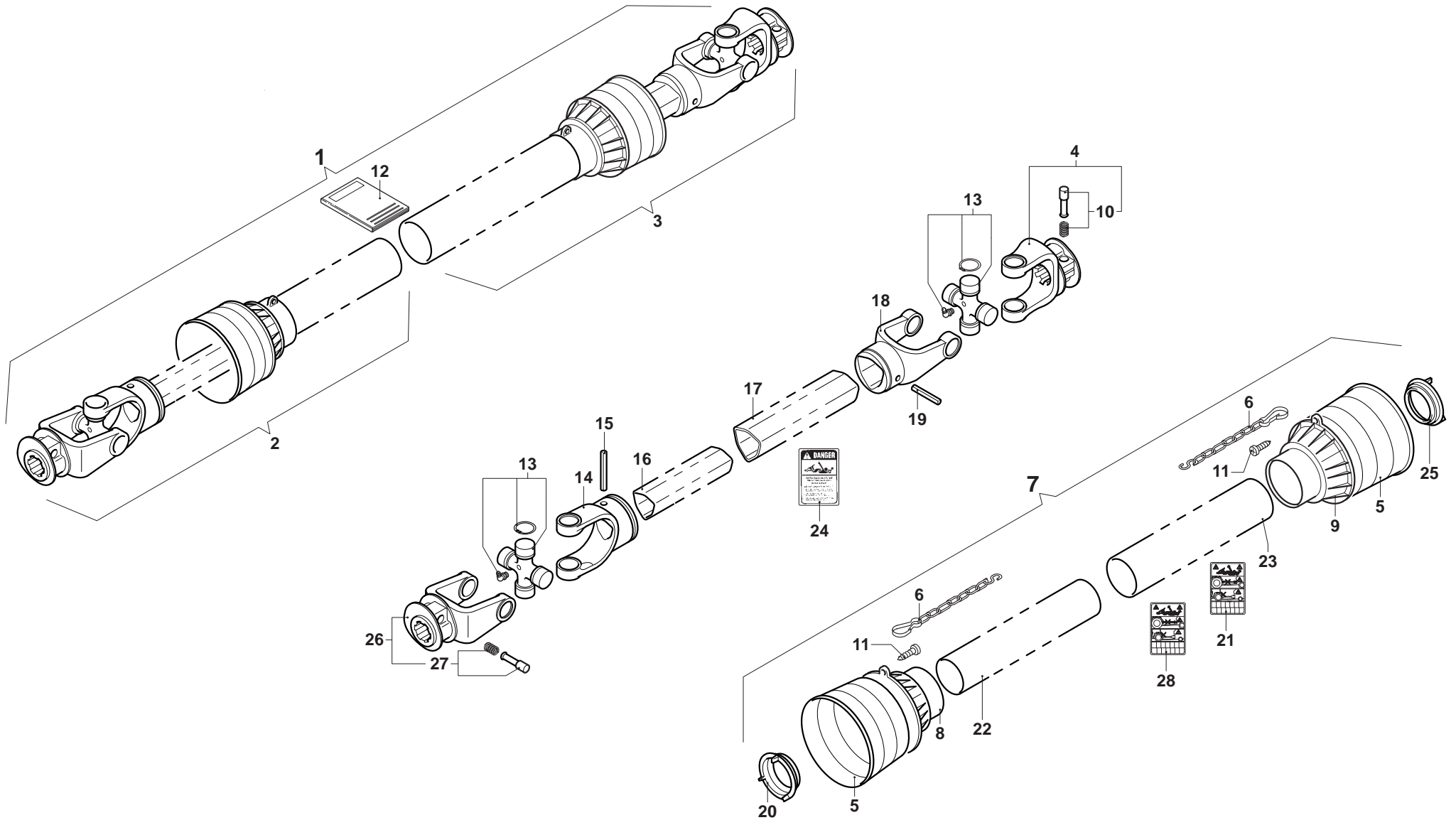



MURATORI S.p.A.

Via Pavarello, 21 - 41051 Castelnuovo Rangone (MO) Italy - Tel. 059.5330611 Fax 059.537259

www.muratoriequip.it *info@muratoriequip.it*

Capitale sociale Euro 480.000 interamente versato

Registro Imprese di Modena

Codice fiscale e numero d'iscrizione: 00708860366