



MURATORI

**TIPO-TYPE-TYP
MT1**

CATALOGO RICAMBI
Catalogue Pièces Detachées
Ersatzteilkatalog
Spare Parts Catalogue
Catálogo Recambios

EDIZIONE 04/2016



**NORME PER LE ORDINAZIONI - COMMANDES/NORMES - BESTELLNORMEN - HOW TO ORDER
INDICE DELLE TAVOLE - INDEX DES TABLES - TAFELVERZEICHNIS - TABLES INDEX**

MT1

Per ordinare parti di ricambio specificare:

- tipo e matricola della macchina (apposti sulla macchina o sui documenti di acquisto);
- numero del riferimento del pezzo nel disegno (Pos.), numero della tavola (Tav.) e numero di codice

N.B.: le indicazioni destro o sinistro vengono date guardando la macchina da dietro.

Pour les commandes de pièces de rechange veuillez spécifier:

- type et numéro de serie de la machine (indiqués sur la machine et sur le bon d'achat);
- numéro de référence du pièce sur le plan (Pos.), numéro du plan (Tav.) et numéro de code (codice)

N.B.: les indications droite ou gauche sont données en regardant la machine par derrière.

Zum Bestellen von Ersatzteilen folgendes angeben:

- Typ und Serien-Nr. der Maschine (zu finden auf der Maschine oder der Einkaufspapieren);
- Bezug-Nr. des Ersatzteils auf der Zeichnung (Pos.), Zeichnungsnummer (Tav.) und Kodenummer (codice)

N.B.: die Angaben rechts und links verstehen sich so, dass man hinter der Maschine steht.

When ordering spare parts specify:

- machine type and serial number (found on the machine or on the purchasing documents);
- reference number of the part on the relative drawing (Pos.), number of the drawing (Tav.) and part number (codice)

N.B.: right-hand or left-hand indications are made by viewing the machine from the rear.

TAV. 1.0

GRUPPO TELAIO
ENSEMBLE CHASSIS
SATZ FÜR RAHMEN
KIT FOR FRAME

TAV. 2.0

GRUPPO TRASMISSIONE ROTORE
ENSEMBLE TRANSMISSION ROTOR
SATZ FÜR DEN ROTARANTRIEB
KIT FOR THE ROTOR TRANSMISSION

TAV.3.0

GRUPPO RULLO POSTERIORE
ENSEMBLE ROULEAU ARRIERE
SATZ HINTERE WALZE
KIT REAR ROLLER

TAV. 4.0

GRUPPO MOLTIPLICATORE - 540 RPM
ENSEMBLE MULTIPLICATEUR - 540 RPM
SATZ FÜR GETRIEBE - 540 RPM
KIT FOR GEAR BOX - 540 RPM

TAV. 5.0

ALBERO CARDANICO COMPLETO - AB106SF
ARBRE A JOINTS DE CARDAN - AB106SF
KARDANWELLE - AB106SF
PTO SHAFT - AB106SF

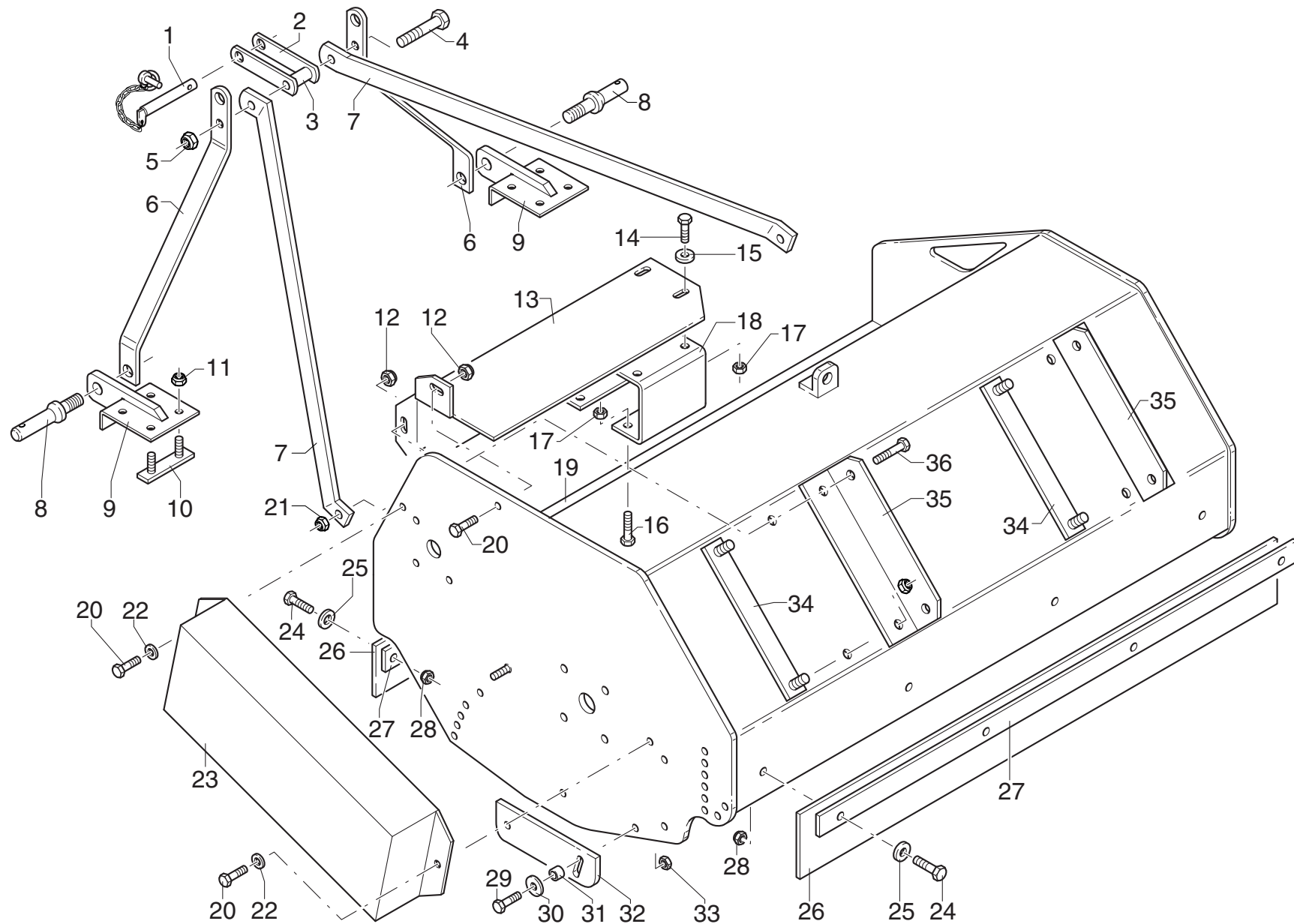

MURATORI MT1

TAV. 1.0

POS.	N° CODICE	Q	DESCRIZIONE	DESIGNATION	BENENNUNG	DESCRIPTION	DESIGNAZIONE	Da matr.	Fino matr
								De nr. serie Vom Seriennr. From serial nr.	Jusqu'au nr. serie Bis Seriennr. Up to serial nr.
1	68062000	1	PERNO	PIVOT	BOLZEN	PIN			
2	40237800	1	ATTACCO	ATTACHE	ANSCHLUSS	ATTACHMENT			
3	32021400	1	BOCCOLA	DOUILLE	BUCHSE	BUSHING			
4	60033000	1	VITE	VIS	SCHRAUBE	SCREW	TE 12x130 UNI 5737		
5	62010600	1	DADO	ECROU	MUTTER	NUT	M 12x1,75 AUTOBLOCC.		
6	30178800	2	TIRANTE	TIRANT	STANGE	TIEROD			
7	30187300	2	TIRANTE	TIRANT	STANGE	TIEROD			
8	68062500	2	PERNO	PIVOT	BOLZEN	PIN			
9	40257700	2	STAFFA	BRIDE	BUEGEL	BRACKET			
10	40231800	4	PIATTO	PLAQUE	PLATTE	DISC			
11	62010600	8	DADO	ECROU	MUTTER	NUT	M 12x1,75 AUTOBLOCC.		
12	62010200	2	DADO	ECROU	MUTTER	NUT	M 8x1,75 AUTOBLOCC.		
13	39279200	1	PROTEZIONE	PROTECTION	SCHUTZ	GUARD	105		
13	39302600	1	PROTEZIONE	PROTECTION	SCHUTZ	GUARD	125		
14	60020700	4	VITE	VIS	SCHRAUBE	SCREW	TE 10x120 UNI 5737		
15	61004900	2	RONDELLA	RONDELLE	SCHEIBE	WASHER	PIANA Ø 10 UNI 6592		
16	60017900	4	VITE	VIS	SCHRAUBE	SCREW	TE 10x25 UNI 5739 8.8 ZNT		
17	62010400	8	DADO	ECROU	MUTTER	NUT	M 10x1,5 AUTOBLOCC.		
18	39279300	1	SUPPORTO	SUPPORT	HALTERUNG	SUPPORT			
19	41116200	1	TELAIO	CHASSIS	RAHMEN	FRAME	105		
19	41121500	1	TELAIO	CHASSIS	RAHMEN	FRAME	125		
20	60022800	3	VITE	VIS	SCHRAUBE	SCREW	TE 8x20 UNI 5739		
21	62010600	2	DADO	ECROU	MUTTER	NUT	M 12x1,75 AUTOBLOCC.		
22	61004700	2	RONDELLA	RONDELLE	SCHEIBE	WASHER	PIANA Ø8 UNI 6592		
23	40254500	1	CARTER	CARTER	SCHUTZABDECKUNG	CASING			
24	60022800		VITE	VIS	SCHRAUBE	SCREW	TE 8x20 UNI 5739		

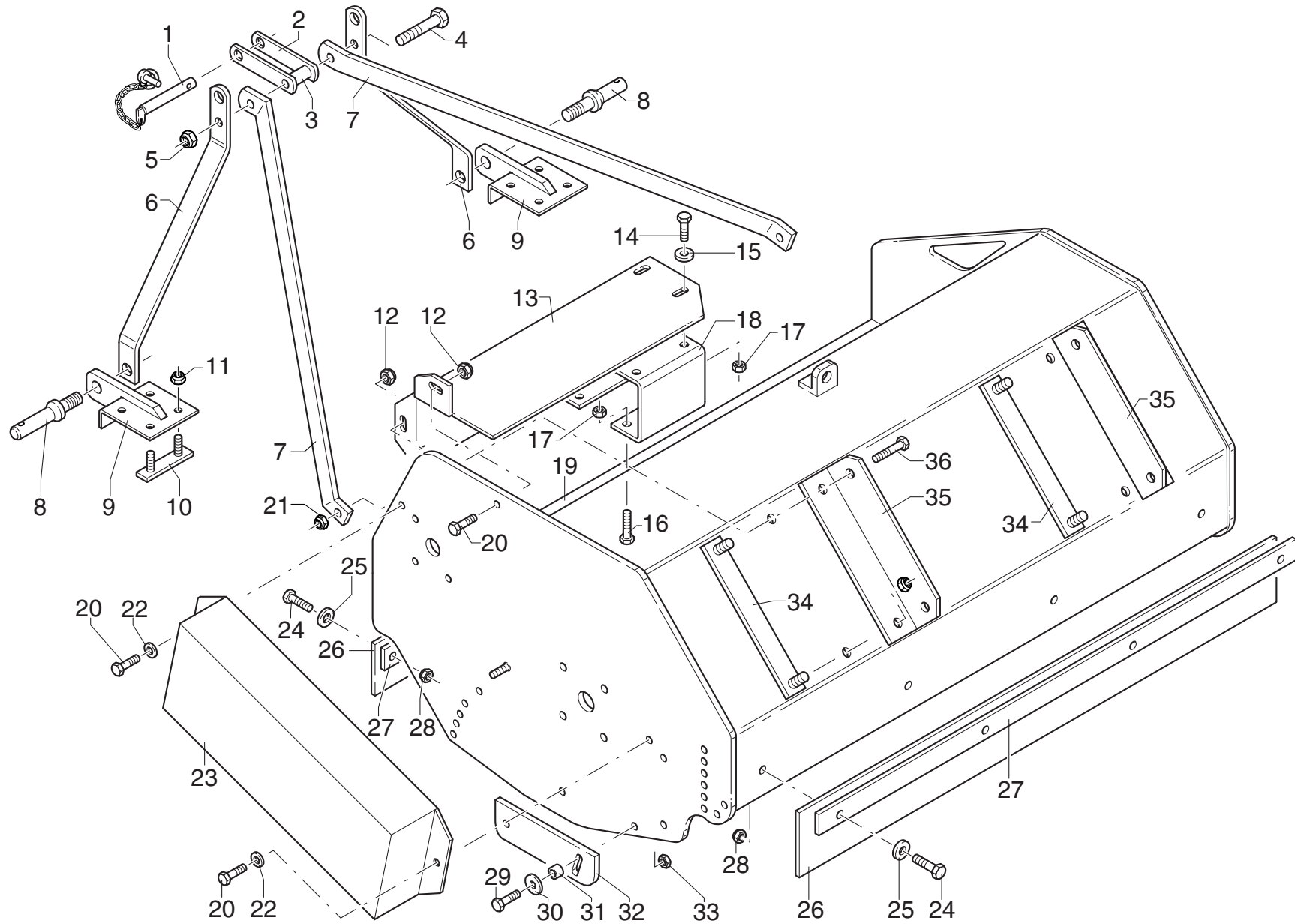

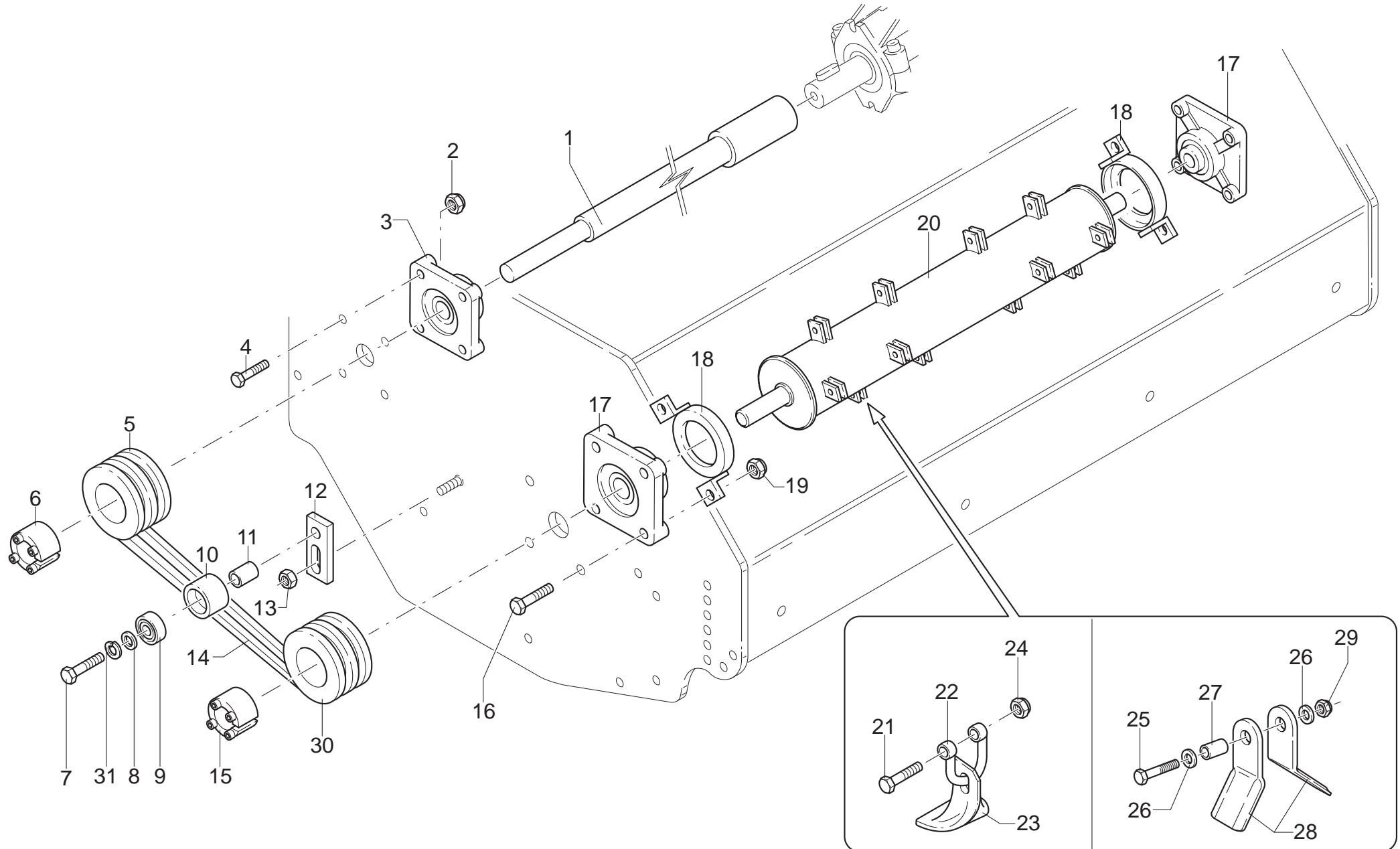

MURATORI MT1

TAV. 2.0

POS.	N° CODICE	Q	DESCRIZIONE	DESIGNATION	BENENNUNG	DESCRIPTION	DESIGNAZIONE	Da matr.	Fino matr
								De nr. serie Vom Seriennr. From serial nr.	Jusqu'au nr. serie Bis Seriennr. Up to serial nr.
1	40228501	1	PROLUNGA	RALLONGE	VERLÄNGERUNGSROHR	EXTENSION	105		
1	40296600	1	PROLUNGA	RALLONGE	VERLÄNGERUNGSROHR	EXTENSION	125		
2	62010400	4	DADO	ECROU	MUTTER	NUT	M 10x1,5 AUTOBLOCC.		
3	67019600	1	SUPPORTO	SUPPORT	HALTERUNG	SUPPORT	UCF 205		
4	60021300	4	VITE	VIS	SCHRAUBE	SCREW	TE 10x30 UNI 5739 8.8 ZNT		
5	68068500	1	PULEGGIA	POULIE	RIEMENSCHLEIBE	PULLEY	Øe 120 Øi 55 2 SPA		
6	68058900	1	CALETTATORE	DOUILLE DE SERRAGE	SPANNBUCHSE	LOCKING DEVICE	Øe 55 Øi 25		
7	60029800	1	VITE	VIS	SCHRAUBE	SCREW	TE 10x40 UNI 5737		102342
7	60042600	1	VITE	VIS	SCHRAUBE	SCREW	TE 10x50 UNI 5739	102343	
8	61004900	1	RONDELLA	RONDELLE	SCHEIBE	WASHER	PIANA Ø10 UNI 6592		129529
8	61003500	2	RONDELLA	RONDELLE	SCHEIBE	WASHER	PIANA Øe 30 Øi 11	129530	
9	67019700	1	CUSCINETTO	ROULEMENT	LAGER	BEARING	6300 2 RS		102342
9	67019700	2	CUSCINETTO	ROULEMENT	LAGER	BEARING	6300 2 RS	102343	129529
9	67019100	2	CUSCINETTO	ROULEMENT	LAGER	BEARING	6204 2 RS	129530	
10	68093500	1	RULLINO	GALET	ROLLE	NEEDLE PIN			102342
10	38025800	1	RULLINO	GALET	ROLLE	NEEDLE PIN		102343	129529
10	38028800	1	RULLINO	GALET	ROLLE	NEEDLE PIN		129530	
11	32180700	1	DISTANZIALE	ENTRETOISE	DISTANZSTÜCK	SPACER			129529
11	38029000	1	DISTANZIALE	ENTRETOISE	DISTANZSTÜCK	SPACER		129530	
12	30196500	1	SUPPORTO	SUPPORT	HALTERUNG	SUPPORT			102342
12	40284200	1	SUPPORTO	SUPPORT	HALTERUNG	SUPPORT		102343	
13	62010400	1	DADO	ECROU	MUTTER	NUT	M 10x1,5 AUTOBLOCC.		
14	68094100		CINGHIA	COURROIE	KEILRIEMEN	BELT	XPA 932		
15	68059000	1	CALETTATORE	DOUILLE DE SERRAGE	SPANNBUCHSE	LOCKING DEVICE	Øe 55 Øi 30		
16	60023500	8	VITE	VIS	SCHRAUBE	SCREW	TE 10x35 UNI 5739 8.8 ZNT		
17	67010200	2	SUPPORTO	SUPPORT	HALTERUNG	SUPPORT	UCF 206		

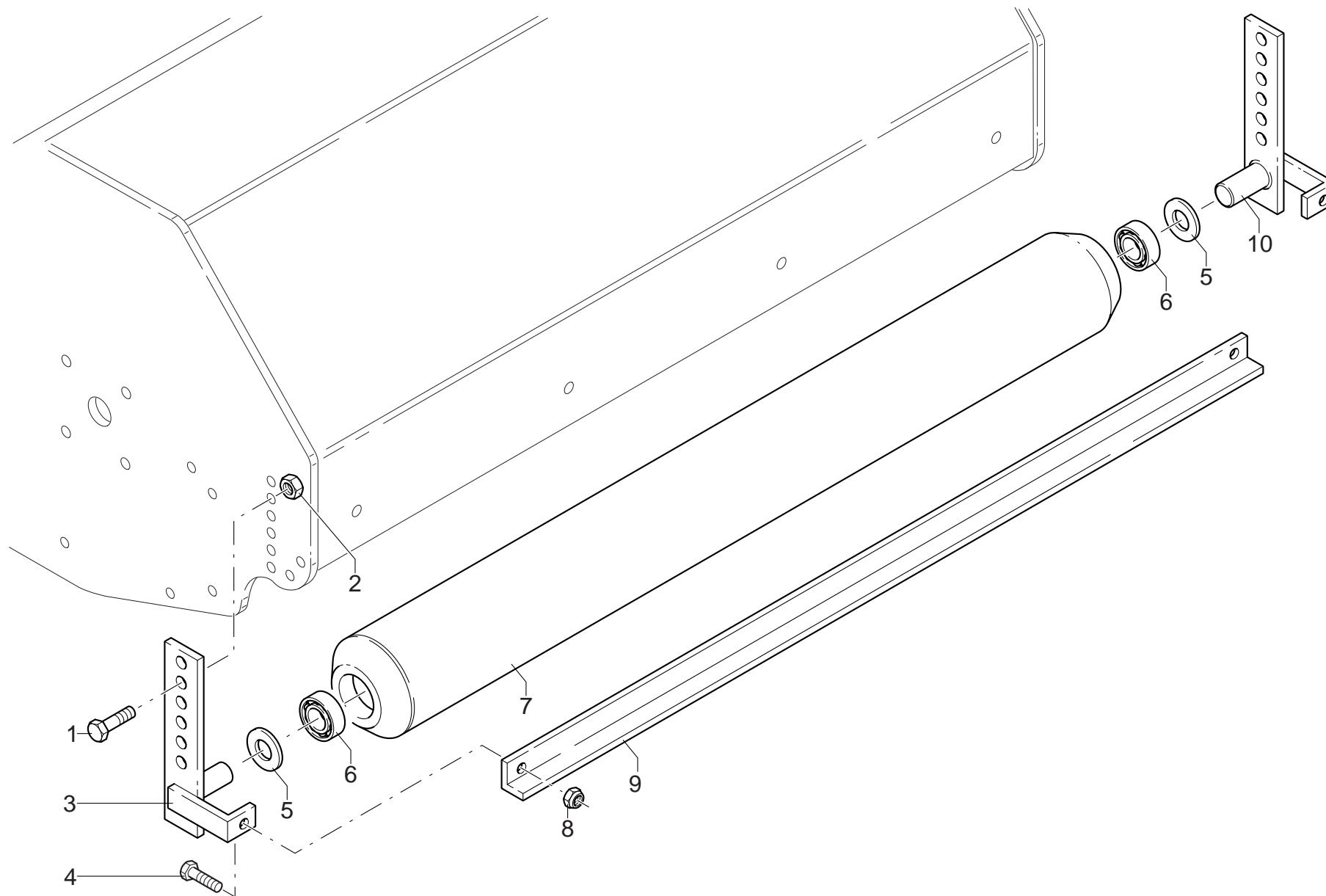

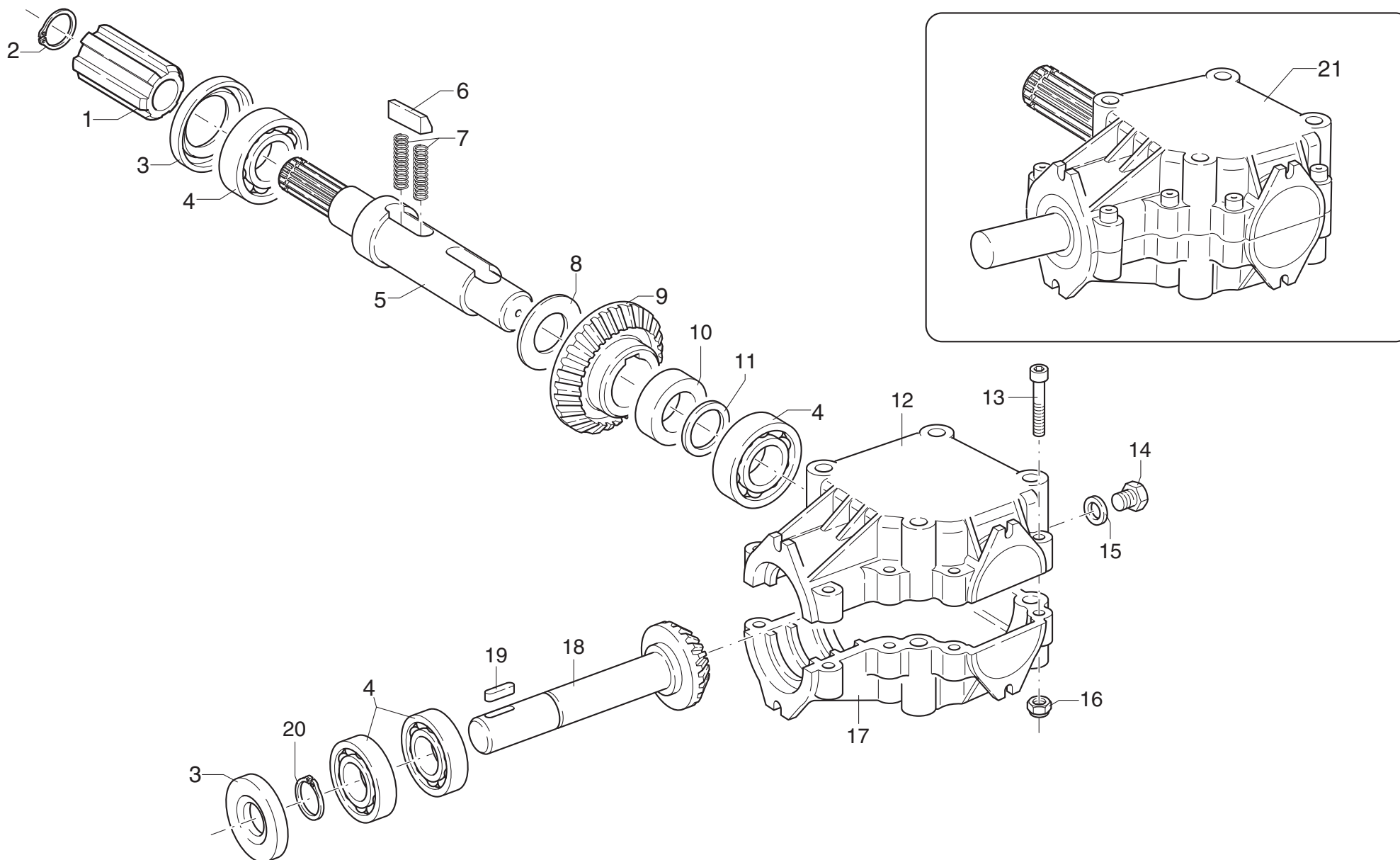

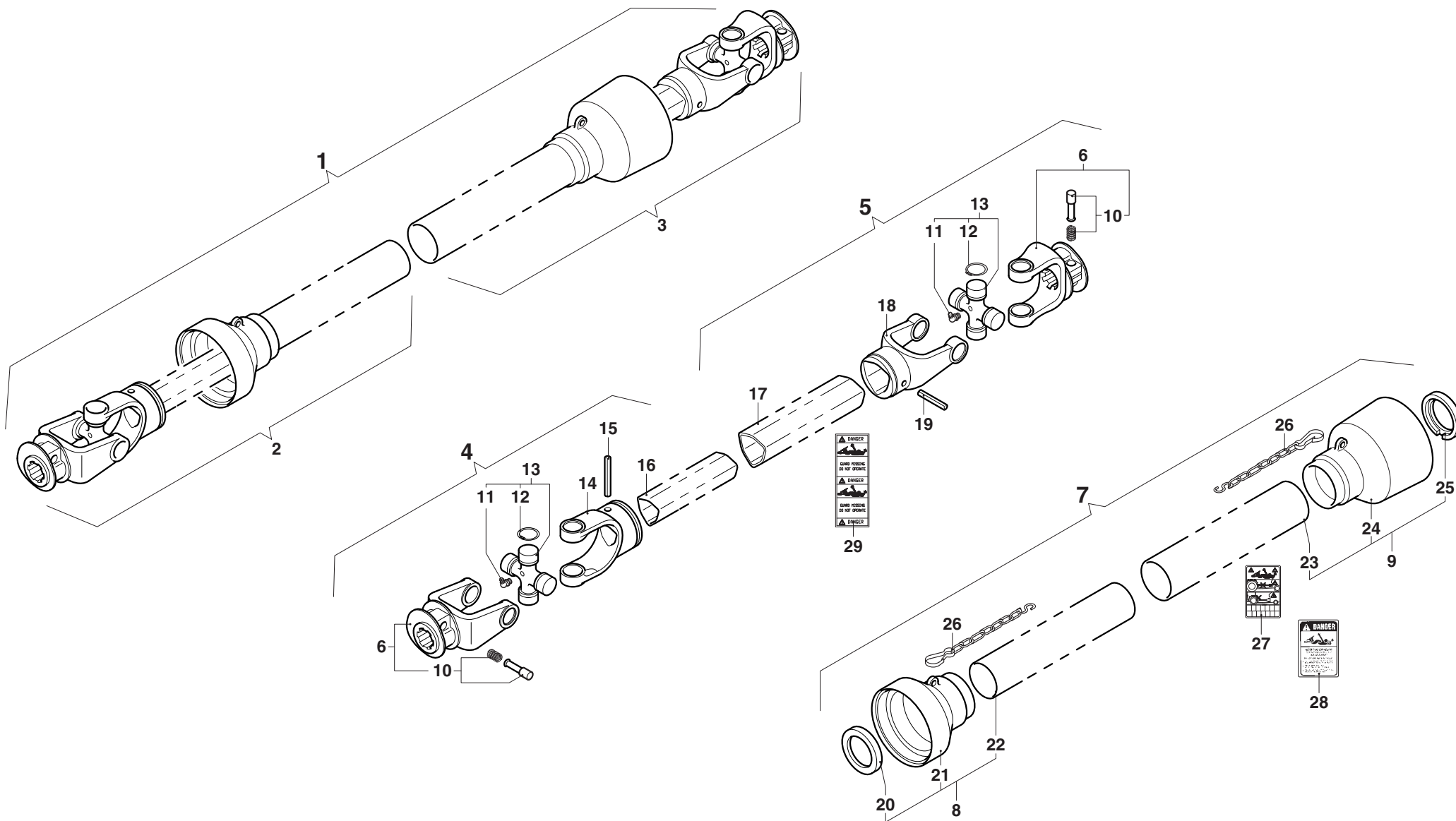

MURATORI MT1

TAV. 5.0

POS.	N° CODICE	Q	DESCRIZIONE	DESIGNATION	BENENNUNG	DESCRIPTION	DESIGNAZIONE	Da matr.	Fino matr
								De nr. serie Vom Seriennr. From serial nr.	Jusqu'au nr. serie Bis Seriennr. Up to serial nr.
1	AB106SF	1	ALBERO CARDANICO COMPLETO	ARBRE A JOINTS DE CARDAN	KARDANWELLE	PTO SHAFT			
2	B1060B1	1	SEMIALBERO INTERNO	DEMI-ARBRE INTERIEUR	INNENHALBWELLE	INTERNAL HALF SHAFT			
3	B1060B2	1	SEMIALBERO ESTERNO	DEMI-ARBRE EXTERIEUR	AUSSENHALBWELLE	EXTERNAL HALF SHAFT			
4	B106001	1	SEMIALBERO INTERNO	DEMI-ARBRE INTERIEUR	INNENHALBWELLE	INTERNAL HALF SHAFT			
5	B106002	1	SEMIALBERO ESTERNO	DEMI-ARBRE EXTERIEUR	AUSSENHALBWELLE	EXTERNAL HALF SHAFT			
6	0800103	2	FORCELLA	FOURCHE	GABEL	YOKE			
7	083B01060	1	PROTEZIONE	PROTECTION	SCHUTZ	GUARD			
8	083B010601	1	PROTEZIONE INTERNA	PROTECTION INTERIEURE	INNENSCHUTZ	INTERNAL GUARD			
9	083B010602	1	PROTEZIONE ESTERNA	PROTECTION EXTERIEURE	AUSSENSCHUTZ	EXTERNAL GUARD			
10	0986014047	2	PULSANTE	BOUTON	DRUCKKNOPF	PUSH BOTTON			
11	09840081002	2	INGRASSATORE	GRAISSEUR	SCHMIERNIPPEL	GREASE FITTING			
12	09802022	8	ANELLO ELASTICO	ARRETOIR	SPANNRING	SNAP-RING			
13	08201	2	CROCIERA	CROISILLON	KREUZSTÜCK	SPIDER			
14	B106002	1	FORCELLA	FOURCHE	GABEL	YOKE			
15	098700840	1	SPINA ELASTICA	GOUPILLE ELASTIQUE	SPANNSTIFT	ELASTIC PIN			
16	09881263100	1	TUBO INTERNO	TUBE INTERIEUR	INNENROHR	INTERNAL TUBE			
17	09881322100	1	TUBO ESTERNO	TUBE EXTERIEUR	AUSSENROHR	EXTERNAL TUBE			
18	08001021	1	FORCELLA	FOURCHE	GABEL	YOKE			
19	098700850	1	SPINA ELASTICA	GOUPILLE ELASTIQUE	SPANNSTIFT	ELASTIC PIN			
20	0265220008	1	GHIERA	FRETTE	NUTMUTTER	RING NUT			
21	0256010425	1	CUFFIA	CAPOUCHON	HAUBE	GUARD			
22	0988955B1060	1	TUBO INTERNO	TUBE INTERIEUR	INNENROHR	INTERNAL TUBE			
23	0988961B1060	1	TUBO ESTERNO	TUBE EXTERIEUR	AUSSENROHR	EXTERNAL TUBE			
24	0256010424	1	CUFFIA	CAPOUCHON	HAUBE	GUARD			
25	0265210007	1	GHIERA	FRETTE	NUTMUTTER	RING NUT			

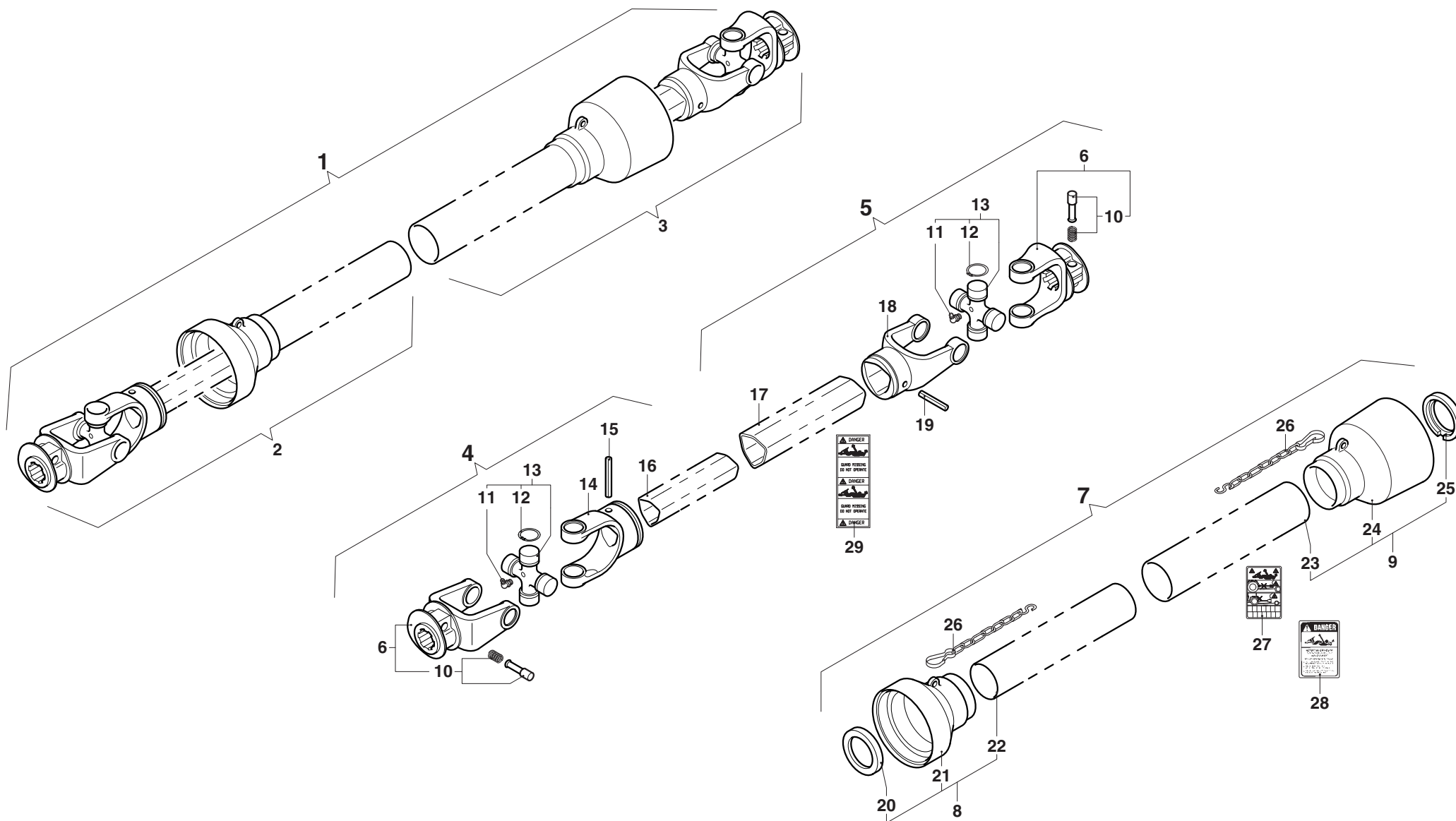



MURATORI S.p.A.

Via Pavarello, 21 - 41051 Castelnuovo Rangone (MO) Italy - Tel. 059.5330611 Fax 059.537259

www.muratoriequip.it *info@muratoriequip.it*

Capitale sociale Euro 480.000 interamente versato

Registro Imprese di Modena

Codice fiscale e numero d'iscrizione: 00708860366