



# MURATORI

**TIPO-TYPE-TYP  
MT 15**

**CATALOGO RICAMBI**  
**Catalogue Pièces Detachées**  
**Ersatzteilkatalog**  
**Spare Parts Catalogue**  
**Catálogo Recambios**

**EDIZIONE 05/2018**



Per ordinare parti di ricambio specificare:

- tipo e matricola della macchina (apposti sulla macchina o sui documenti di acquisto);
- numero del riferimento del pezzo nel disegno (Pos.), numero della tavola (Tav.) e numero di codice

**N.B.:** le indicazioni destro o sinistro vengono date guardando la macchina da dietro.

*Pour les commandes de pièces de rechange veuillez spécifier:*

- *type et numéro de série de la machine (indiqués sur la machine et sur le bon d'achat);*
- *numéro de référence du pièce sur le plan (Pos.), numéro du plan (Tav.) et numéro de code (codice)*

**N.B.:** *les indications droite ou gauche sont données en regardant la machine par derrière.*

*Zum Bestellen von Ersatzteilen folgendes angeben:*

- *Typ und Serien-Nr. der Maschine (zu finden auf der Maschine oder der Einkaufspapieren);*
- *Bezug-Nr. des Ersatzteils auf der Zeichnung (Pos.), Zeichnungsnummer (Tav.) und Kodenummer (codice)*

**N.B.:** *die Angaben rechts und links verstehen sich so, dass man hinter der Maschine steht.*

When ordering spare parts specify:

- machine type and serial number (found on the machine or on the purchasing documents);
- reference number of the part on the relative drawing (Pos.) number of the drawing (Tav.) and part number (codice)

**N.B.:** right-hand or left-hand indications are made by viewing the machine from the rear.

**TAV. 1.0**

GRUPPO TELAIO  
ENSEMBLE CHASSIS  
SATZ FÜR RAHMEN  
KIT FOR FRAME

**TAV. 2.0**

GRUPPO TRASMISSIONE ROTORE  
ENSEMBLE TRANSMISSION ROTOR  
SATZ FÜR DEN ROTARANTRIEB  
KIT FOR THE ROTOR TRANSMISSION

**TAV. 3.0**

GRUPPO RULLO POSTERIORE  
ENSEMBLE ROULEAU ARRIERE  
SATZ HINTERE WALZE  
KIT REAR ROLLER

**TAV. 4.0**

GRUPPO MOLTIPLICATORE  
ENSEMBLE MULTIPLICATEUR  
SATZ FÜR GETRIEBE  
KIT FOR GEAR BOX

**TAV. 5.0**

ACCESSORI A COMPLETAMENTO  
OPTIONS D'ACHEVEMENT  
ZUBEHÖRE ZUR ERGANZUNG DER MASCHINE  
CHOICE OF EQUIPMENT COMPLETING MACHINE

**TAV. 6.0**

ACCESSORI A COMPLETAMENTO  
OPTIONS D'ACHEVEMENT  
ZUBEHÖRE ZUR ERGANZUNG DER MASCHINE  
CHOICE OF EQUIPMENT COMPLETING MACHINE

**TAV. 7.0**

ALBERO CARDANICO COMPLETO - AB207SF  
ARBRE A JOINTS DE CARDAN - AB207SF  
KARDANWELLE - AB207SF  
PTO SHAFT - AB207SF

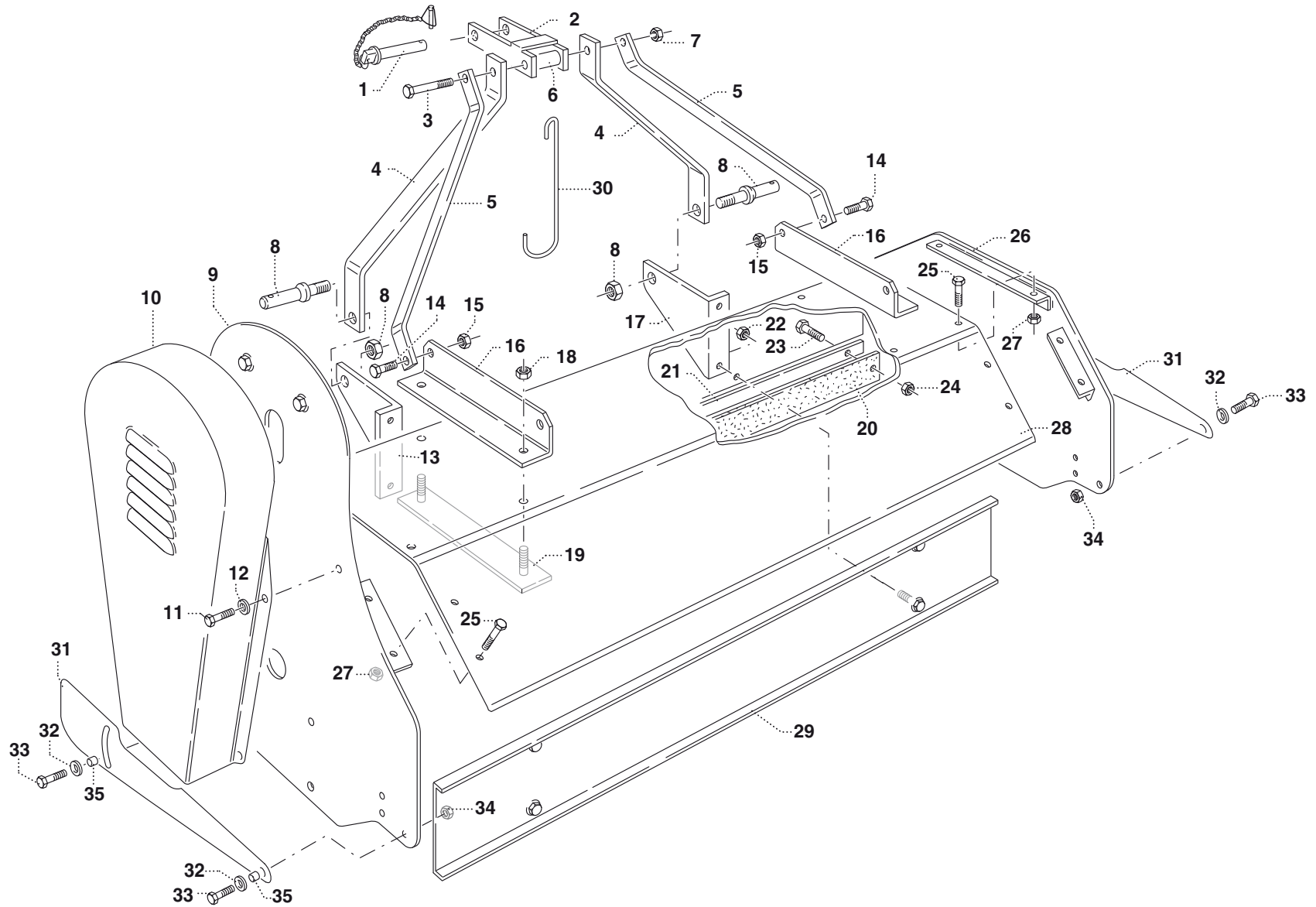

# MURATORI MT15

# TAV. 1.0

POS.	N° CODICE	Q.	DESCRIZIONE	DESIGNATION	BENENNUNG	DESCRIPTION	DESIGNAZIONE	Da matr. De nr. serie Vom Seriennr. From serial nr.	Fino matr. Jusqu'au nr. serie Bis Seriennr. Up to serial nr.
1	68062000	1	PERNO	PIVOT	BOLZEN	PIN			
2	40237800	1	ATTACCO	ATTACHE	ANSCHLUSS	ATTACHMENT			
3	60033000	1	VITE	VIS	SCHRAUBE	SCREW	TE 12 x 130 UNI 5737		
4	30178800	2	TIRANTE	TIRANT	STANGE	TIEROD			
5	30178900	2	TIRANTE	TIRANT	STANGE	TIEROD			
6	32021400	1	DISTANZIALE	ENTRETOISE	DISTANZSTUECK	SPACER			
7	62010600	1	DADO	ECROU	MUTTER	NUT	M 12 x 1,75 AUTOBLOCC.		
8	68062500	2	PERNO	PIVOT	BOLZEN	PIN			
9	40315900	1	PIASTRA CARTER	PLAQUE	SEITENWAND	SIDE FRAME			
10	40227701	1	COPERCHIO	COUVERCLE	DECKEL	COVER			
11	60022800	4	VITE	VIS	SPINDEL	SCREW	TE 8 x 20 UNI 5739		
12	61006200	4	RONDELLA	RONDELLE	SCHEIBE	WASHER	PIANA Øi 9 Øe24 sp.1,5		
13	39251500	1	STAFFA SX	BRIDE (G)	BUEGEL (LINKS)	BRACKET (LH)			
14	60023000	2	VITE	VIS	SCHRAUBE	SCREW	TE 12 x 30 UNI 5739		
15	62010600	2	DADO	ECROU	MUTTER	NUT	M 12 x 1,75 AUTOBLOCC.		
16	39251700	2	STAFFA	BRIDE	BUEGEL	BRACKET			
17	39251600	1	STAFFA DX	BRIDE (D)	BUEGEL(RECHTS)	BRACKET (RH)			
18	62010600	4	DADO	ECROU	MUTTER	NUT	M 12 x 1,75 AUTOBLOCC.		
19	40231700	2	CONTROFLANGIA	CONTRE-BRIDE	GEGENFLANSCH	COUNTERFLANGE			
20	68067800	1	BANDELLA	BANDE	BAND	STRAP	105		
20	68067900	1	BANDELLA	BANDE	BAND	STRAP	130		
20	68068000	1	BANDELLA	BANDE	BAND	STRAP	155		
21	30125500	1	PIATTO	PLAQUE	PLATTE	DISC	105		
21	30125600	1	PIATTO	PLAQUE	PLATTE	DISC	130		
21	30125700	1	PIATTO	PLAQUE	PLATTE	DISC	155		
22	62010600	4	DADO	ECROU	MUTTER	NUT	M 12 x 1,75 AUTOBLOCC.		

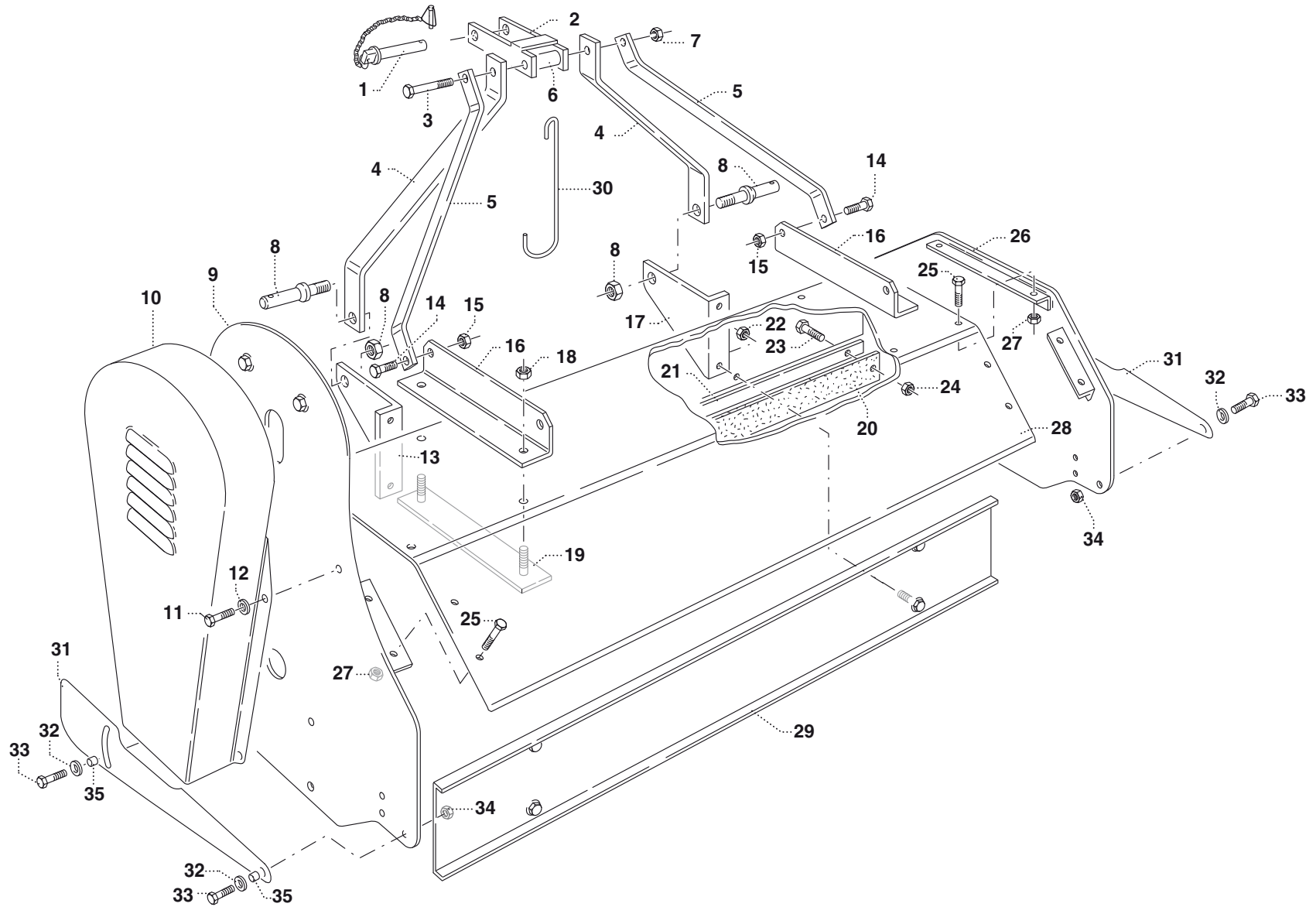



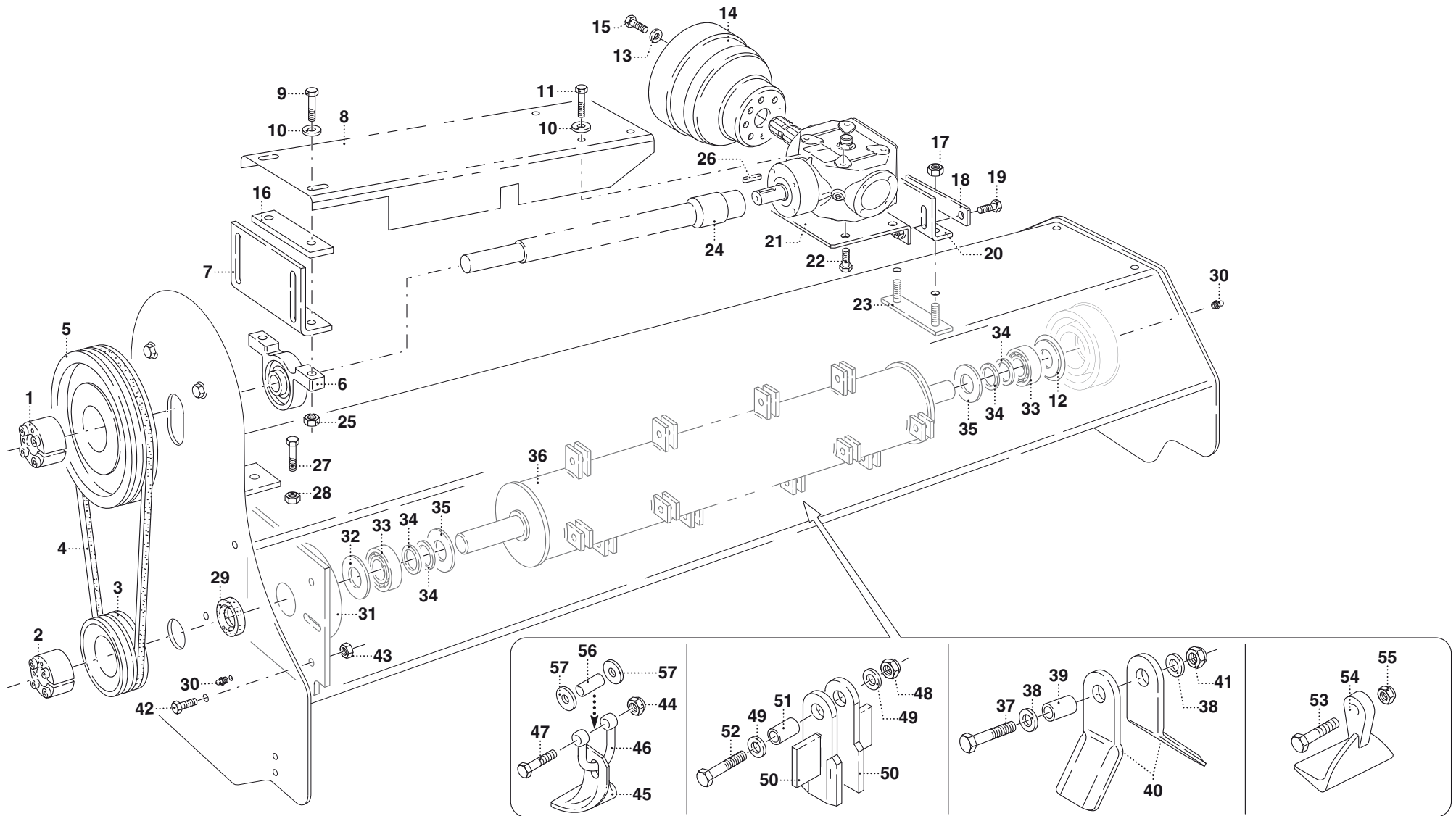

# MURATORI MT15

# TAV. 2.0

POS.	N° CODICE	Q.	DESCRIZIONE	DESIGNATION	BENENNUNG	DESCRIPTION	DESIGNAZIONE	Da matr. De nr. serie Vom Seriennr. From serial nr.	Fino matr. Jusqu'au nr. serie Bis Seriennr. Up to serial nr.
1	68058900	1	CALETTATORE	DOUILLE DE SERRAGE	SPANNBUCHSE	LOCKING DEVICE	Øi 25 Øe 55		
2	68059000	1	CALETTATORE	DOUILLE DE SERRAGE	SPANNBUCHSE	LOCKING DEVICE	Øi 30 Øe 55		
3	68058800	1	PULEGGIA	POULIE	RIEMENSCHLEIBE	PULLEY	Ø 100 2 SPA		
4	68082000	2	CINGHIA	COURROIE	KEILRIEMEN	BELT	A 43		
5	68121500	1	PULEGGIA	POULIE	RIEMENSCHLEIBE	PULLEY	Ø 170 2 SPA		
6	67012600	1	SUPPORTO	SUPPORT	HALTERUNG	SUPPORT	UCP 205		
7	39253600	1	REGOLAZIONE	REGULATEUR	MECHANISCHER REGLER	GOVERNOR			
8	40265801	1	PROTEZIONE	PROTECTION	SCHUTZ	GUARD	105		
8	40265901	1	PROTEZIONE	PROTECTION	SCHUTZ	GUARD	130		
8	40266001	1	PROTEZIONE	PROTECTION	SCHUTZ	GUARD	155		
9	60027000	2	VITE	VIS	SCHRAUBE	SCREW	TE 12 x 70 UNI 5737		
10	61000900	2	RONDELLA	RONDELLE	SCHEIBE	WASHER	PIANA Ø12 UNI 6592		
11	60023000	2	VITE	VIS	SCHRAUBE	SCREW	TE 12 x 30 UNI 5739		
12	32171000	1	SPESSORE	EPAISSEUR	DISTANZRING	SPACER			
13	61004700	2	RONDELLA	RONDELLE	SCHEIBE	WASHER	PIANA Ø8 UNI 6592		
14	68074300	1	PROTEZIONE	PROTECTION	SCHUTZ	GUARD			
15	60015100	2	VITE	VIS	SCHRAUBE	SCREW	TE 8 x 16 UNI 5739		
16	30212500	1	SPESSORE	EPAISSEUR	DISTANZRING	SPACER			
17	62010600	2	DADO	ECROU	MUTTER	NUT	M 12 x 1,75 AUTOBLOCC.		
18	30175300	1	PIATTO BLOCCAGGIO	PLAQUE	PLATTE	DISC			
19	60023000	2	VITE	VIS	SCHRAUBE	SCREW	TE 12 x 30 UNI 5739		
20	39333500	1	SOSTEGNO	SUPPORT	TRAEGER	SUPPORT			
21	40316100	1	SUPPORTO	SUPPORT	HALTERUNG	SUPPORT			
22	60021600	4	VITE	VIS	SCHRAUBE	SCREW	TE 10 x 20 UNI 5739		
23	40231800	1	PIATTO	PLAQUE	PLATTE	DISC			
24	40228501	1	PROLUNGA	RALLONGE	VERLAENGERUNGSROHR	EXTENSION	105		

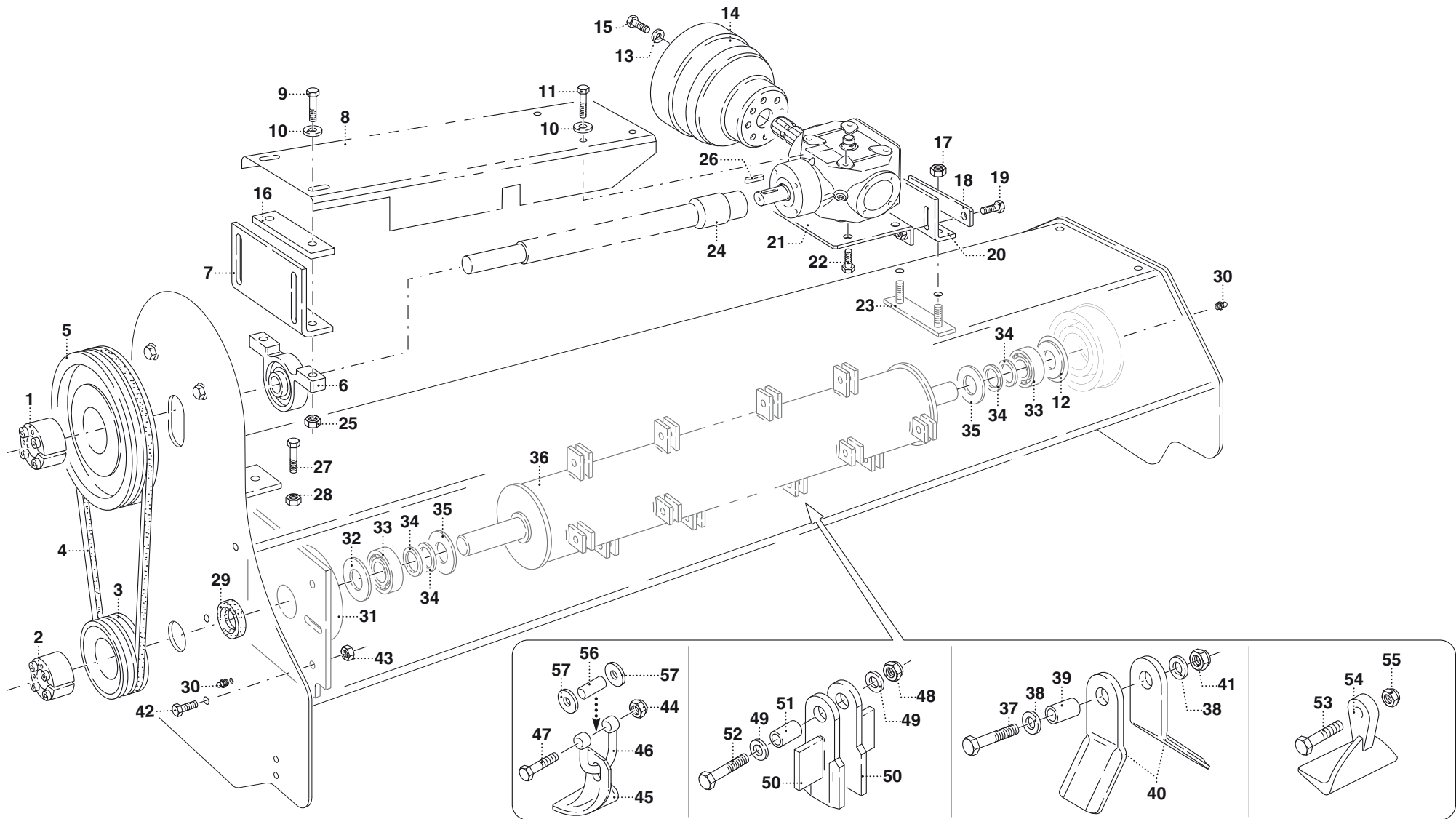

# MURATORI MT15

# TAV. 2.0

POS.	N° CODICE	Q.	DESCRIZIONE	DESIGNATION	BENENNUNG	DESCRIPTION	DESIGNAZIONE	Da matr. De nr. serie Vom Seriennr. From serial nr.	Fino matr. Jusqu'au nr. serie Bis Seriennr. Up to serial nr.
24	40228601	1	PROLUNGA	RALLONGE	VERLAENGERUNGSROHR	EXTENSION	130		
24	40228701	1	PROLUNGA	RALLONGE	VERLAENGERUNGSROHR	EXTENSION	155		
25	62010600	2	DADO	ECROU	MUTTER	NUT	M 12 x 1,75 AUTOBLOCC.		
26	65001100	1	LINGUETTA	CLAVETTE	FEDER	KEY	8 x 7 x 30		
27	60035500	1	VITE	VIS	SCHRAUBE	SCREW	TE 12 x 50 UNI 5739		
28	62000600	1	DADO	ECROU	MUTTER	NUT	M 12 x 1,75 UNI 5587		
29	66014000	1	ANELLO TENUTA	JOINT D'ETANCHEITE	DICHTUNGSRING	JUNT RING	30 x 40 x 4		
30	64000200	2	INGRASSATORE	GRAISSEUR	SCHMIERNIPPEL	GREASE FITTING	M6 x 1		
31	40228000	1	SUPPORTO SX	SUPPORT (G)	HALTER (LINKS)	SUPPORT (LH)			
32	32068000	1	SPESSORE	EPAISSEUR	DISTANZRING	SPACER			
33	67012900	2	CUSCINETTO	ROULEMENT	LAGER	BEARING	1306		
34	68068800		SPESSORE	EPAISSEUR	DISTANZRING	SPACER	42 x 30 x 1		
35	39091100	2	DISCO	DISQUE	SCHEIBE	DISC			
36	42045400	1	ROTORE	ROTOR	ROTOR	ROTOR	105		
36	42045500	1	ROTORE	ROTOR	ROTOR	ROTOR	130		
36	42045600	1	ROTORE	ROTOR	ROTOR	ROTOR	155		
37	60012900		VITE	VIS	SCHRAUBE	SCREW	TE 8 x 45 UNI 5737		
38	61006200		RONDELLA	RONDELLE	SCHEIBE	WASHER	PIANA Ø 9		
39	31042800		BOCCOLA	DOUILLE	BUECHSE	BUSHING			
40	12010200		COLTELLO	COUTEAU	MESSER	KNIFE			
41	62010200		DADO	ECROU	MUTTER	NUT	M 8 AUTOBLOCC.		
42	60020400	4	VITE	VIS	SCHRAUBE	SCREW	TE 12 x 25 UNI 5739		
43	62010600	4	DADO	ECROU	MUTTER	NUT	M 12 x 1,75 AUTOBLOCC.		
44	62010800		DADO	ECROU	MUTTER	NUT	M 14 x 2 AUTOBLOCC.		136326
44	62010400		DADO	ECROU	MUTTER	NUT	M 10 x 1,5 AUTOBLOCC.	136327	
45	12015100		COLTELLO A SPATOLE	COUTEAU	MESSER	KNIFE			

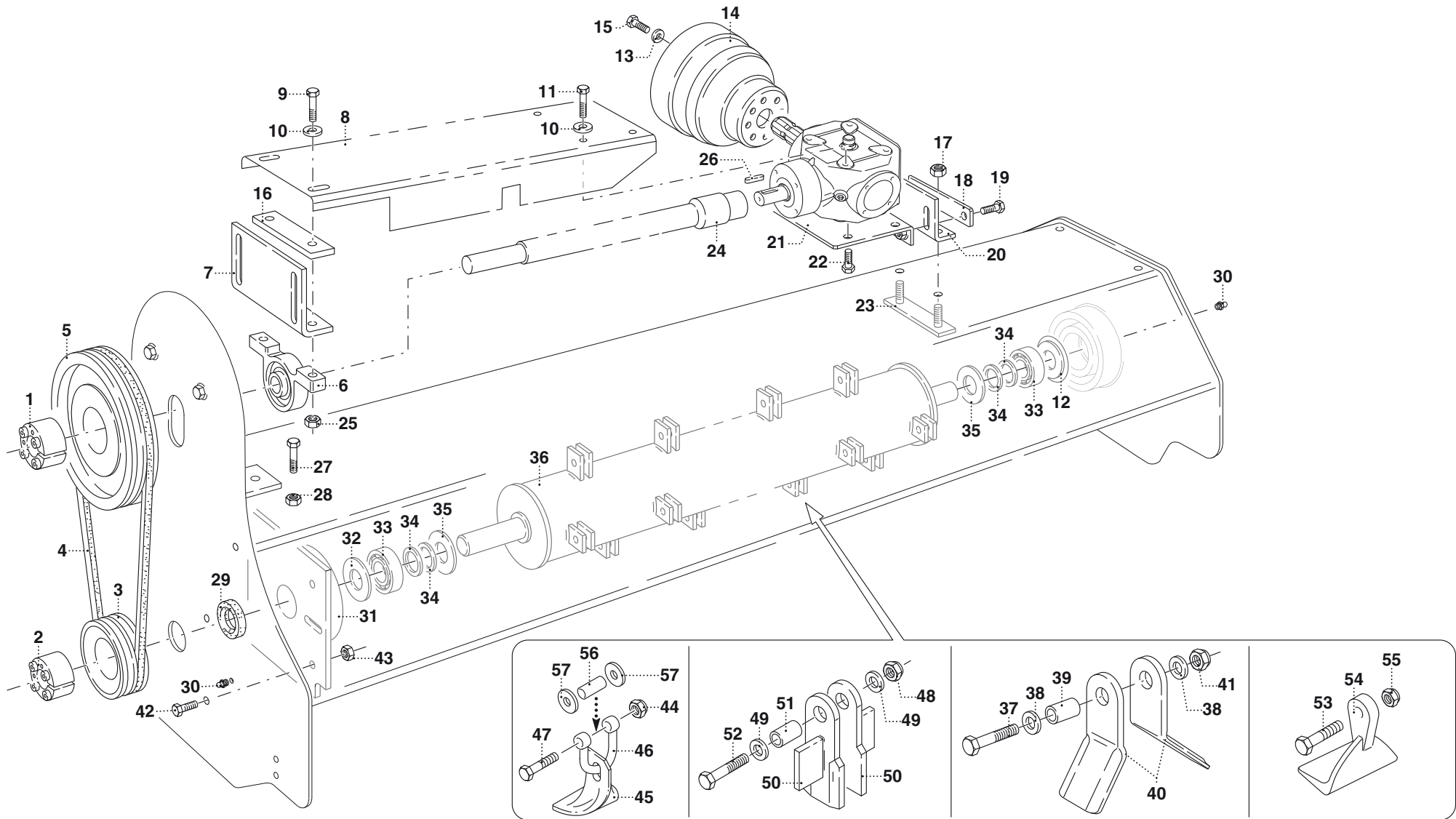



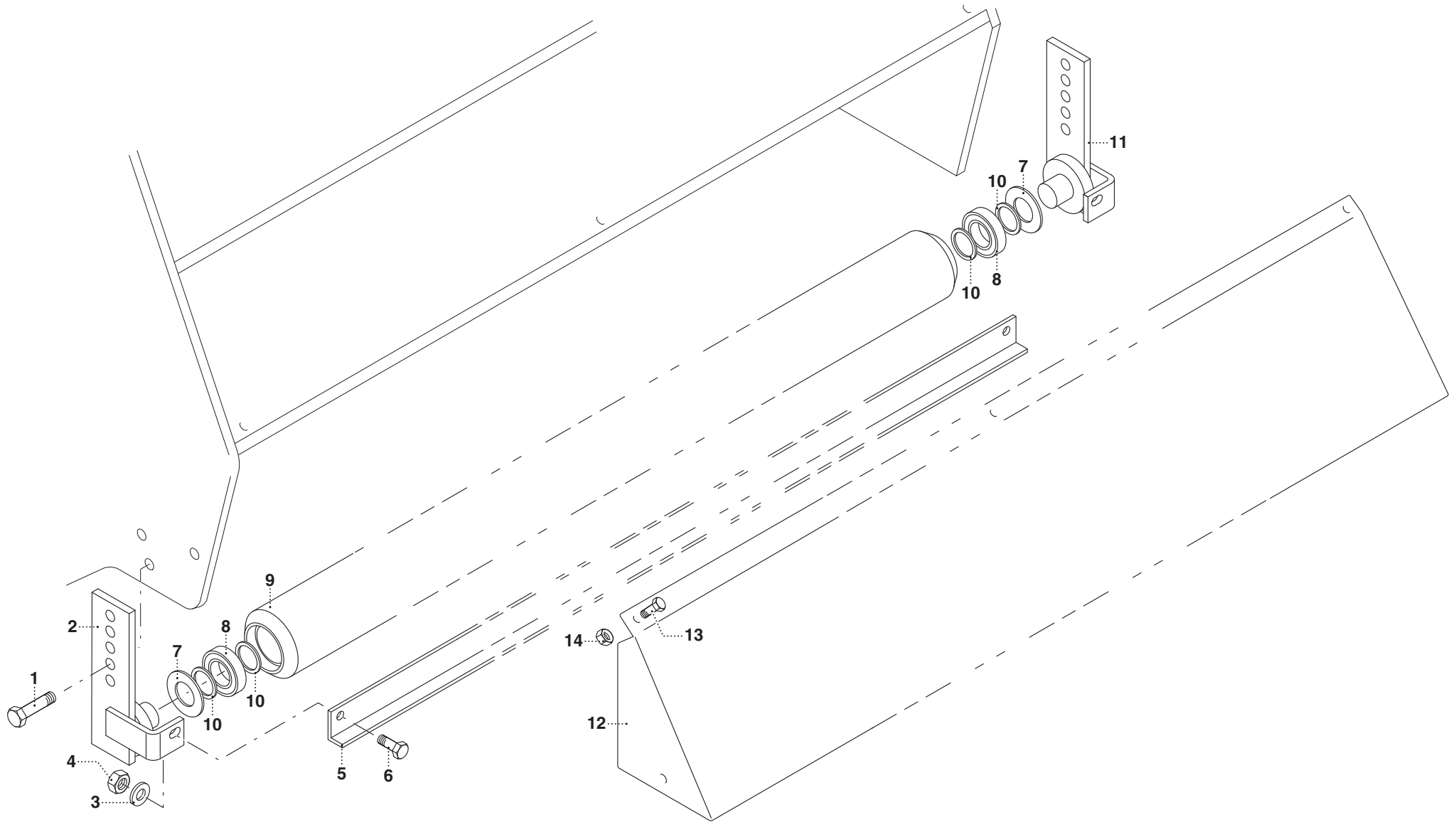



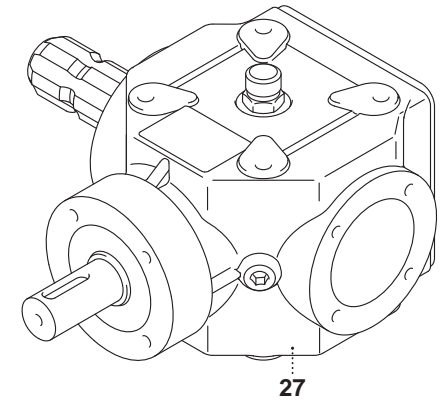
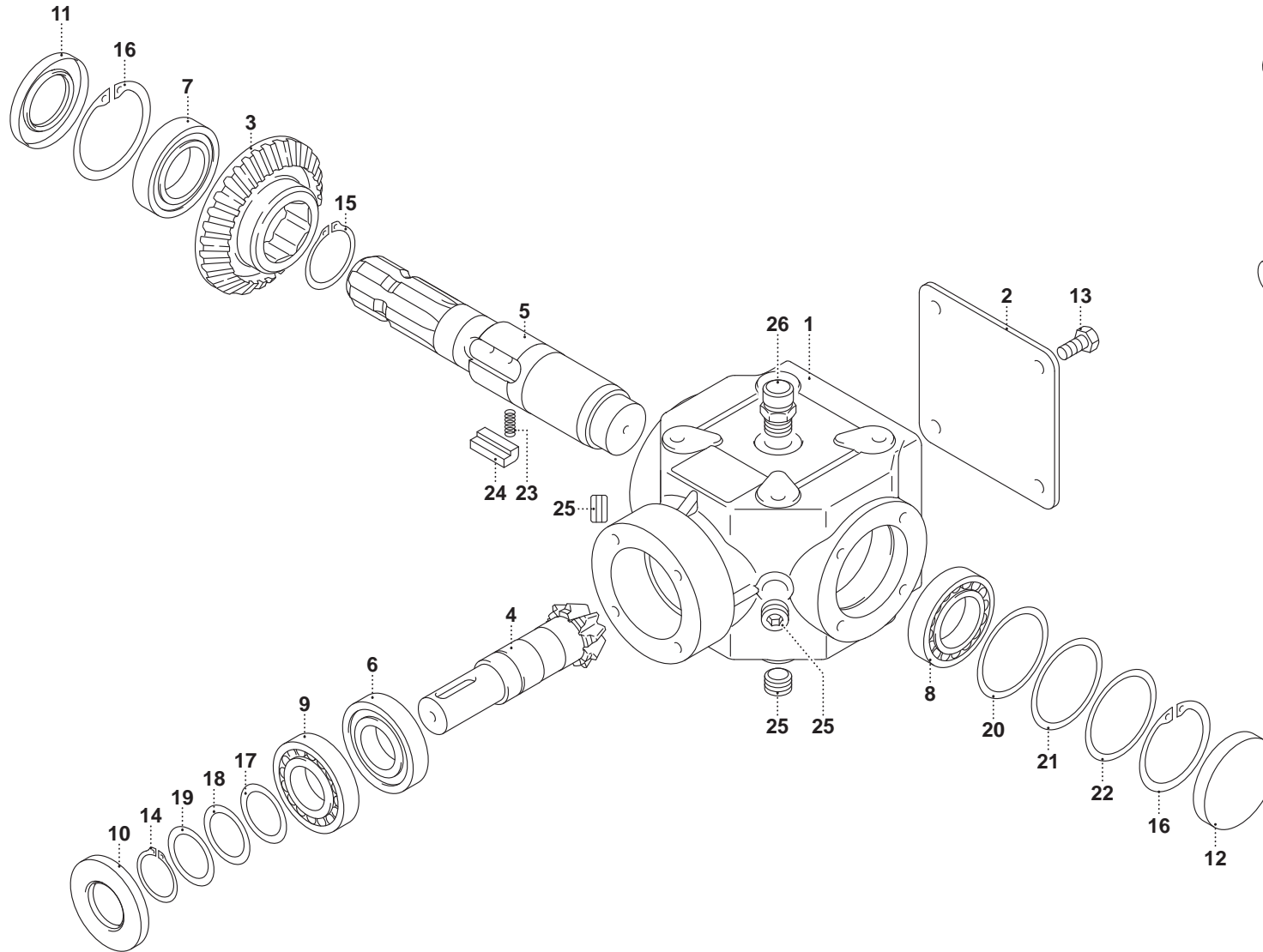

# MURATORI MT15

# TAV. 4.0

POS.	N° CODICE	Q.	DESCRIZIONE	DESIGNATION	BENENNUNG	DESCRIPTION	DESIGNAZIONE	Da matr. De nr. serie Vom Seriennr. From serial nr.	Fino matr. Jusqu'au nr. serie Bis Seriennr. Up to serial nr.
1	01020400	1	SCATOLA	CARTER	GEHAEUSE	GEARBOX			
2	39340600	1	COPERCHIO	COUVERCLE	DECKEL	COVER			
3	10050900	1	CORONA	COURONNE	KRANZ	CROWN			
4	10051000	1	PIGNONE	PIGNON	RITZEL	PINION			
5	31099200	1	ALBERO	ARBRE	WELLE	SHAFT			
6	67015700	1	CUSCINETTO	ROULEMENT	LAGER	BEARING	30206		
7	67017200	1	CUSCINETTO	ROULEMENT	LAGER	BEARING	30207		
8	67018500	1	CUSCINETTO	ROULEMENT	LAGER	BEARING	6007		
9	67018600	1	CUSCINETTO	ROULEMENT	LAGER	BEARING	6206		
10	66019700	1	ANELLO TENUTA	JOINT D'ETANCHEITE	DICHTUNGSRING	JUNT RING	30 x 62 x 8		
11	66011600	1	ANELLO TENUTA	JOINT D'ETANCHEITE	DICHTUNGSRING	JUNT RING	35 x 62 x 7		
12	68123900	1	CAPPELOTTO	BOUCHON	ABSCHLUSSKAPPE	CAP NUT	62 x 9,5		
13	60015100	4	VITE	VIS	SCHRAUBE	SCREW	TE 8 x 16 UNI 5739		
14	63005700	1	ANELLO ELASTICO	ARRETOIR	SPANNRING	SNAP-RING	Ø30 E UNI 7436		
15	63005000	1	ANELLO ELASTICO	ARRETOIR	SPANNRING	SNAP-RING	Ø42 E UNI 7435		
16	63001700	1	ANELLO ELASTICO	ARRETOIR	SPANNRING	SNAP-RING	Ø62 I UNI 7437		
17	68124000	1	SPESSORE	EPAISSEUR	DISTANZRING	SPACER	30 x 40 x 0,1		
18	68124100	1	SPESSORE	EPAISSEUR	DISTANZRING	SPACER	30 x 40 x 0,5		
19	68124200	1	SPESSORE	EPAISSEUR	DISTANZRING	SPACER	30 x 40 x 1		
20	68039000	1	SPESSORE	EPAISSEUR	DISTANZRING	SPACER	62 x 50 x 0,3		
21	68124300	1	SPESSORE	EPAISSEUR	DISTANZRING	SPACER	62 x 50 x 0,5		
22	68011500	2	SPESSORE	EPAISSEUR	DISTANZRING	SPACER	62 x 50 x 1		
23	68124400	6	MOLLA	RESSORT	FEDER	SPRING			
24	65003500	3	CHIAVETTA	CLAVETTE	KEIL	SPLINE			
25	68124500	3	TAPPO	BOUCHON	STOPFEN	PLUG			
26	68085600	1	TAPPO	BOUCHON	STOPFEN	PLUG			

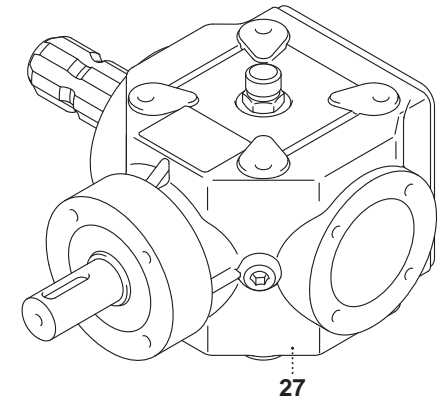
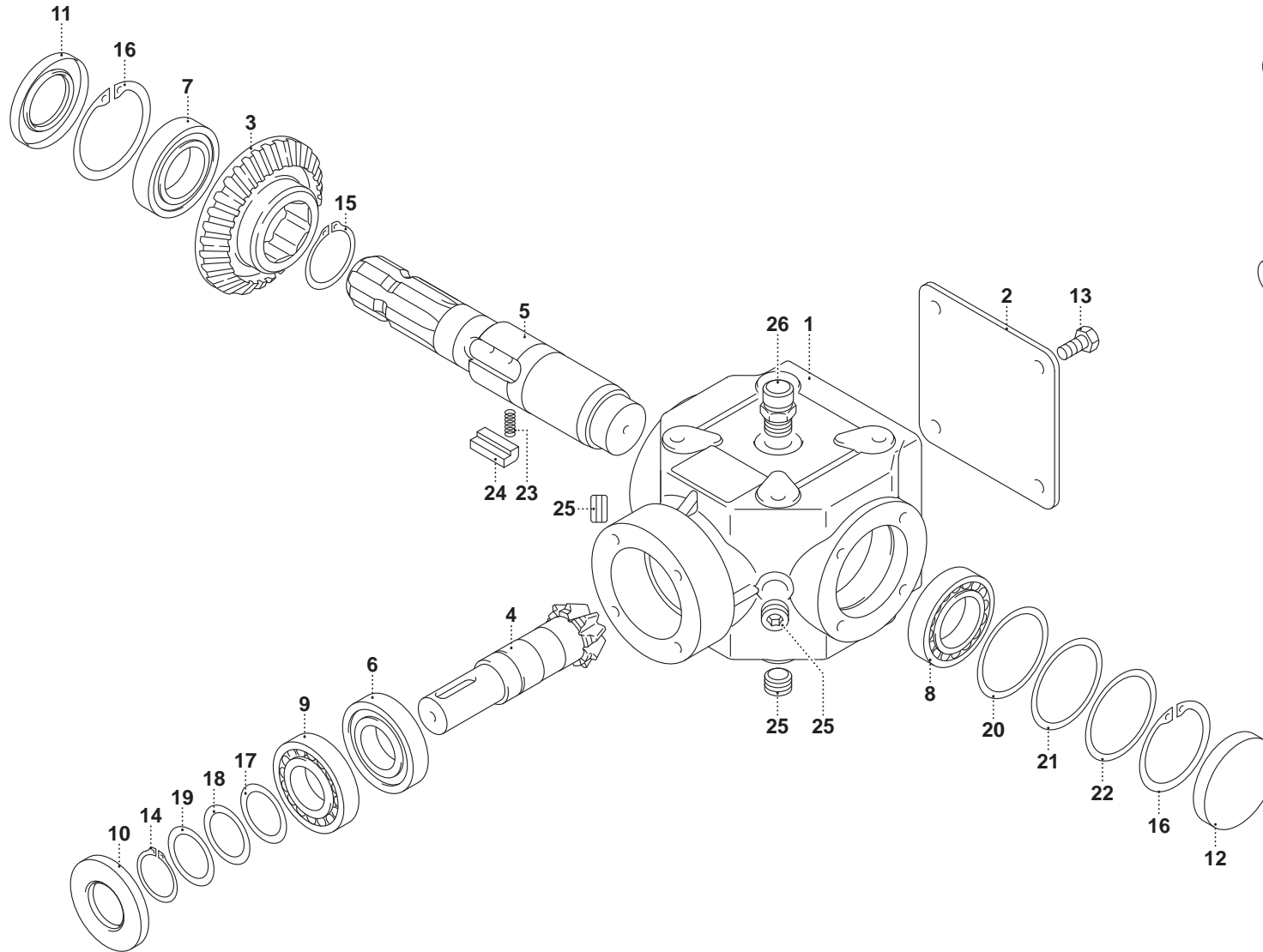



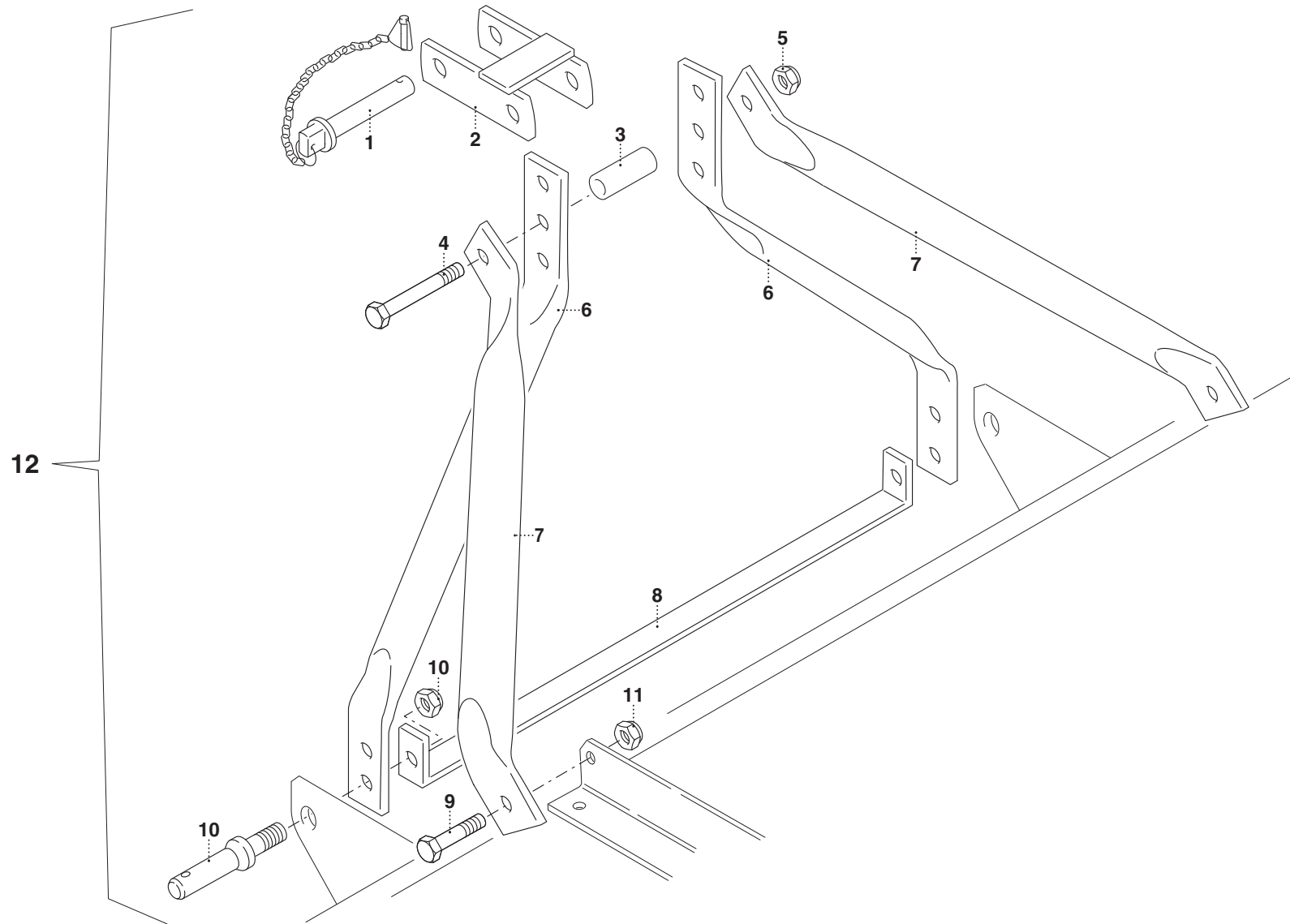



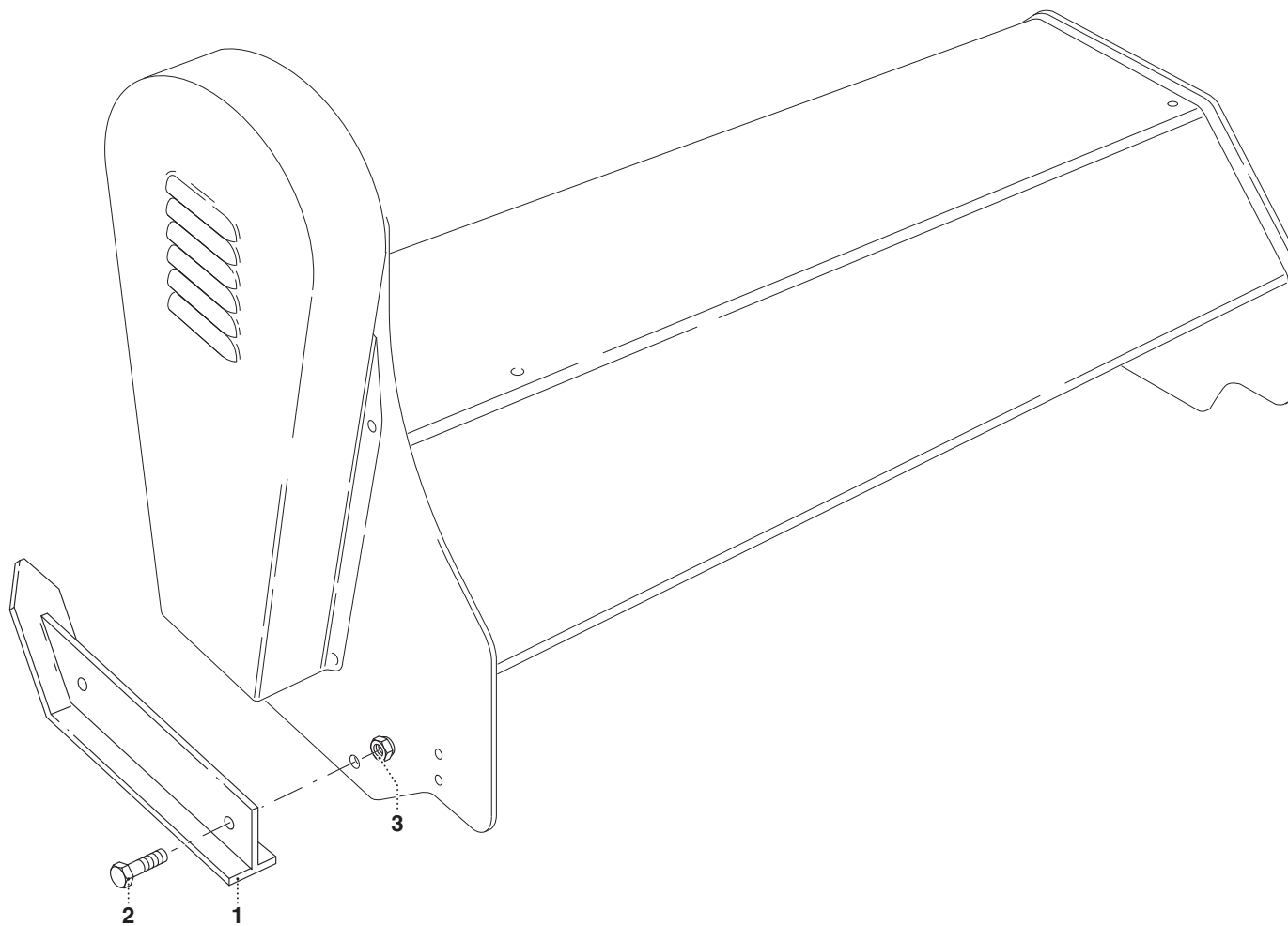



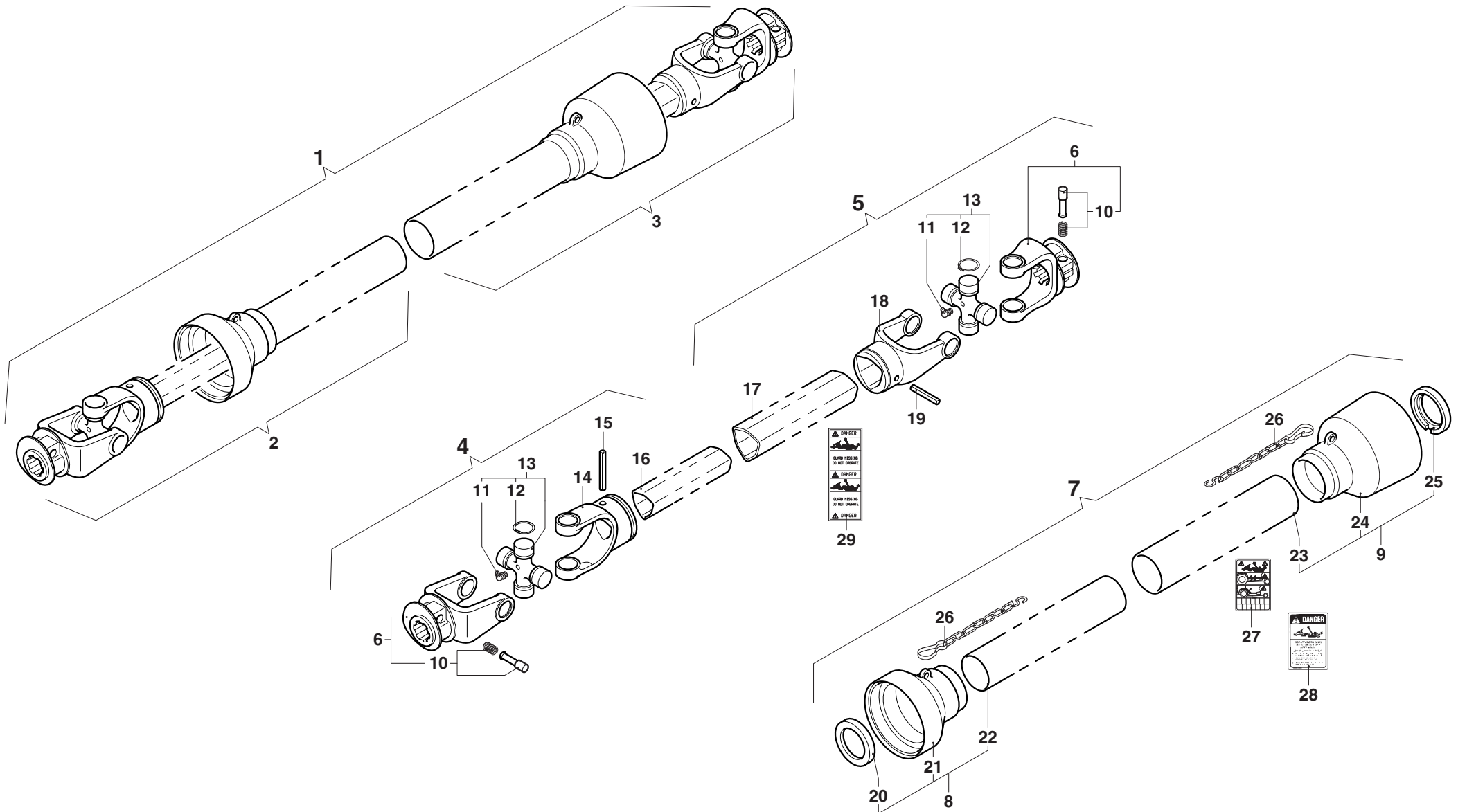

# MURATORI MT15

# TAV. 7.0

POS.	N° CODICE	Q.	DESCRIZIONE	DESIGNATION	BENENNUNG	DESCRIPTION	DESIGNAZIONE	Da matr. De nr. serie Vom Seriennr. From serial nr.	Fino matr. Jusqu'au nr. serie Bis Seriennr. Up to serial nr.
1	AB207SF	1	ALBERO CARDANICO COMPLETO	ARBRE A JOINTS DE CARDAN	KARDANWELLE	PTO SHAFT			
2	B2070B1	1	SEMIALBERO INTERNO	DEMI-ARBRE INTERIEUR	INNENHALBWELLE	INTERNAL HALF SHAFT			
3	B2070B2	1	SEMIALBERO ESTERNO	DEMI-ARBRE EXTERIEUR	AUSSENHALBWELLE	EXTERNAL HALF SHAFT			
4	B207001	1	SEMIALBERO INTERNO	DEMI-ARBRE INTERIEUR	INNENHALBWELLE	INTERNAL HALF SHAFT			
5	B2070002	1	SEMIALBERO ESTERNO	DEMI-ARBRE EXTERIEUR	AUSSENHALBWELLE	EXTERNAL HALF SHAFT			
6	0800203	2	FORCELLA	FOURCHE	GABEL	YOKE			
7	083B02070	1	PROTEZIONE	PROTECTION	SCHUTZ	GUARD			
8	083B020701	1	PROTEZIONE INTERNA	PROTECTION INTERIEURE	INNENSCHUTZ	INTERNAL GUARD			
9	083B020702	1	PROTEZIONE ESTERNA	PROTECTION EXTERIEURE	AUSSENSCHUTZ	EXTERNAL GUARD			
10	0986014047	2	PULSANTE	BOUTON	DRUCKKNOPF	PUSH BOTTON			
11	09840081002	2	INGRASSATORE	GRAISSEUR	SCHMIERNIPPEL	GREASE FITTING			
12	098020224	8	ANELLO ELASTICO	ARRETOIR	SPANNRING	SNAP-RING			
13	08202	2	CROCIERA	CROISILLON	KREUZSTUECK	SPIDER			
14	08002011	1	FORCELLA	FOURCHE	GABEL	YOKE			
15	098700850	1	SPINA ELASTICA	GOUPILLE ELASTIQUE	SPANNSTIFT	ELASTIC PIN			
16	09881294100	1	TUBO INTERNO	TUBE INTERIEUR	INNENROHR	INTERNAL TUBE			
17	09881363100	1	TUBO ESTERNO	TUBE EXTERIEUR	AUSSENROHR	EXTERNAL TUBE			
18	08002021	1	FORCELLA	FOURCHE	GABEL	YOKE			
19	098700855	1	SPINA ELASTICA	GOUPILLE ELASTIQUE	SPANNSTIFT	ELASTIC PIN			
20	0265220008	1	GHIERA	FRETTE	NUTMUTTER	RING NUT			
21	0256010425	1	CUFFIA	CAPOUCHON	HAUBE	GUARD			
22	0988955B2070	1	TUBO INTERNO	TUBE INTERIEUR	INNENROHR	INTERNAL TUBE			
23	0988961B2070	1	TUBO ESTERNO	TUBE EXTERIEUR	AUSSENROHR	EXTERNAL TUBE			
24	0256010424	1	CUFFIA	CAPOUCHON	HAUBE	GUARD			
25	0265220007	1	GHIERA	FRETTE	NUTMUTTER	RING NUT			

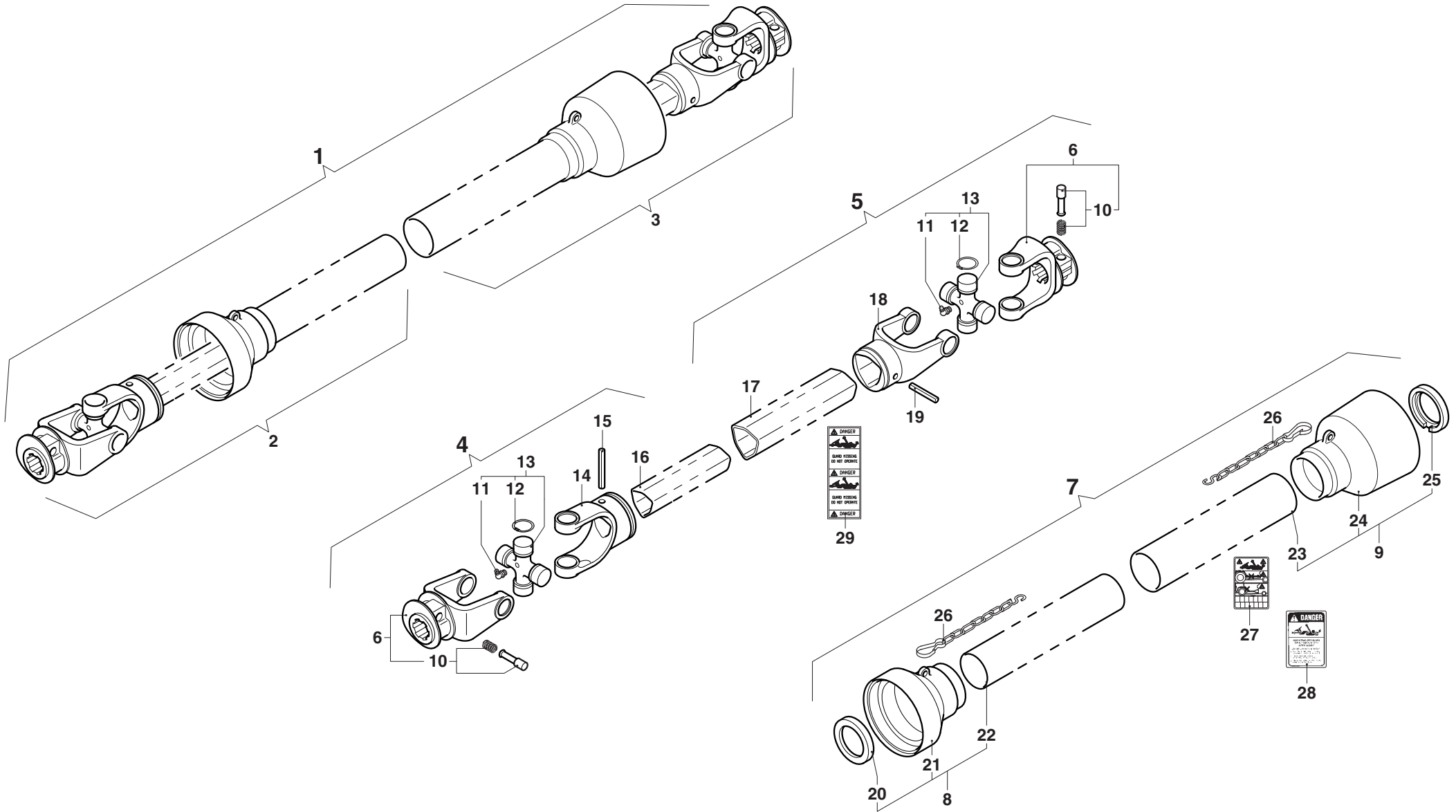









**MURATORI S.p.A.**

Via Pavarello, 21 - 41051 Castelnuovo Rangone (MO) Italy - Tel. 059.5330611 Fax 059.537259

**[www.muratoriequip.it](http://www.muratoriequip.it)** *info@muratoriequip.it*

**Capitale sociale Euro 480.000 interamente versato**

**Registro Imprese di Modena**

**Codice fiscale e numero d'iscrizione: 00708860366**