



MURATORI

**TIPO-TYPE-TYP
MT 20 H**

CATALOGO RICAMBI
Catalogue Pièces Detachées
Ersatzteilkatalog
Spare Parts Catalogue
Catálogo Recambios

EDIZIONE 02/2022



**NORME PER LE ORDINAZIONI - COMMANDES/NORMES - BESTELLNORMEN - HOW TO ORDER
INDICE DELLE TAVOLE - INDEX DES TABLES - TAFELVERZEICHNIS - TABLES INDEX**

MT 20 H

Per ordinare parti di ricambio specificare:

- tipo e matricola della macchina (apposti sulla macchina o sui documenti di acquisto);
- numero del riferimento del pezzo nel disegno (Pos.), numero della tavola (Tav.) e numero di codice

N.B.: le indicazioni destro o sinistro vengono date guardando la macchina da dietro.

Pour les commandes de pièces de rechange veuillez spécifier:

- type et numéro de serie de la machine (indiqués sur la machine et sur le bon d'achat);
- numéro de référence du pièce sur le plan (Pos.), numéro du plan (Tav.) et numero de code (codice)

N.B.: les indications droite ou gauche sont données en regardant la machine par derrière.

Zum Bestellen von Ersatzteilen folgendes angeben:

- Typ und Serien-Nr. der Maschine (zu finden auf der Maschine oder der Einkaufspapieren);
- Bezug-Nr. des Ersatzteils auf der Zeichnung (Pos.), Zeichnungsnummer (Tav.) und Kodenummer (codice)

N.B.: die Angaben rechts und links verstehen sich so, dass man hinter der Maschine steht.

When ordering spare parts specify:

- machine type and serial number (found on the machine or on the purchasing documents);
- reference number of the part on the relative drawing (Pos.), number of the drawing (Tav.) and part number (codice)

N.B.: right-hand or left-hand indications are made by viewing the machine from the rear.

TAV. 1.0
GRUPPO TELAIO
ENSEMBLE CHASSIS
SATZ FÜR RAHMEN
KIT FOR FRAME

TAV. 2.0
GRUPPO TRASMISSIONE ROTORE
ENSEMBLE TRANSMISSION ROTOR
SATZ FÜR DEN ROTARANTRIEB
KIT FOR THE ROTOR TRANSMISSION

TAV.3.0
GRUPPO RULLO POSTERIORE
ENSEMBLE ROULEAU ARRIERE
SATZ HINTERE WALZE
KIT REAR ROLLER

TAV. 4.0
GRUPPO MOLTIPLICATORE
ENSEMBLE MULTIPLICATEUR
SATZ FÜR GETRIEBE
KIT FOR GEAR BOX

TAV.5.0
ACCESSORI A COMPLETAMENTO
OPTIONS D'ACHEVEMENT
ZUBEHÖRE ZUR ERGANZUNG DER MASCHINE
CHOICE OF EQUIPMENT COMPLETING MACHINE

TAV.6.0
ACCESSORI A COMPLETAMENTO
OPTIONS D'ACHEVEMENT
ZUBEHÖRE ZUR ERGANZUNG DER MASCHINE
CHOICE OF EQUIPMENT COMPLETING MACHINE

TAV. 7.0
ALBERO CARDANICO COMPLETO - AB207SF
ARBRE A JOINTS DE CARDAN - AB207SF
KARDANWELLE - AB207SF
PTO SHAFT - AB207SF

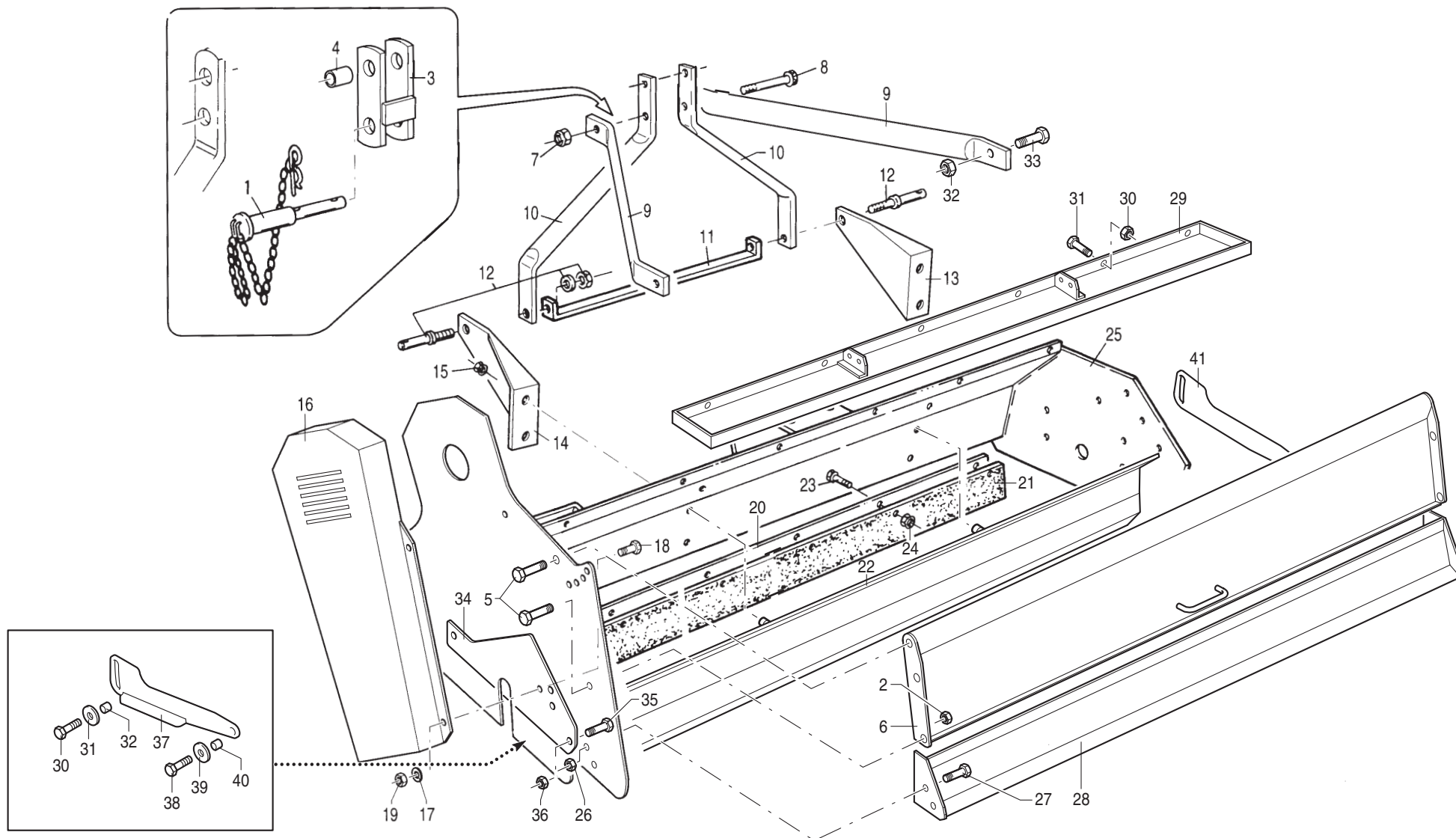

MURATORI MT 20 H

TAV. 1.0

POS.	N°	CODICE Q.	DESCRIZIONE	DESIGNATION	BENENNUNG	DESCRIPTION	DESIGNAZIONE	Da matr.	Fino matr.
								De nr. serie Vom Seriennr. From serial nr.	Jusqu'au nr. serie Bis Seriennr. Up to serial nr.
1	68062000	1	PERNO	PIVOT	BOLZEN	PIN			
2	62010600	4	DADO	ECROU	MUTTER	NUT	M 12 x 1,75 AUTOBLOCC.		
3	40237800	1	STAFFA	BRIDE	BUEGEL	BRACKET			
4	32021400	1	BOCCOLA	DOUILLE	BUECHSE	BUSHING			
5	60023000	4	VITE	VIS	SCHRAUBE	SCREW	TE 12 x 30 UNI 5739		
6	41117000	1	COFANO	CAPOT	SCHUTZHAUBE	HOOD	105		
6	41117100	1	COFANO	CAPOT	SCHUTZHAUBE	HOOD	130		
6	41117200	1	COFANO	CAPOT	SCHUTZHAUBE	HOOD	155		
7	62010600	1	DADO	ECROU	MUTTER	NUT	M 12 x 1,75 AUTOBLOCC.		
8	60011900	1	VITE	VIS	SCHRAUBE	SCREW	TE 12 x 120 UNI 5737		
9	30182800	2	TIRANTE	TIRANT	STANGE	TIEROD			
10	32183600	2	TIRANTE	TIRANT	STANGE	TIEROD			
11	30199700	1	TIRANTE	TIRANT	STANGE	TIEROD			
12	68062500	2	PERNO	PIVOT	BOLZEN	PIN			
13	39168900	1	MENSOLA DX	CONSOLE (D)	KONSOLE (RECHTS)	BRACKET (RH)			
14	39169000	1	MENSOLA SX	CONSOLE (G)	KONSOLE (LINKS)	BRACKET (LH)			
15	62010600	4	DADO	ECROU	MUTTER	NUT	M 12 x 1,75 AUTOBLOCC.		
16	40227700	1	CARTER	CARTER	SCHUTZABDECKUNG	CASING			
17	61006200	4	RONDELLA	RONDELLE	SCHEIBE	WASHER	PIANA Øi 9 Øe 24		
18	60022800	2	VITE	VIS	SCHRAUBE	SCREW			
19	62010200	4	DADO	ECROU	MUTTER	NUT	M 8 x 1,25 AUTOBLOCC.		
20	30125500	1	PIATTO	PLAQUE	PLATTE	PLATE	105		
20	30125600	1	PIATTO	PLAQUE	PLATTE	PLATE	130		
20	30125700	1	PIATTO	PLAQUE	PLATTE	PLATE	155		
21	68067800	1	BANDELLA	BANDE	BAND	STRAP	105		
21	68067900	1	BANDELLA	BANDE	BAND	STRAP	130		

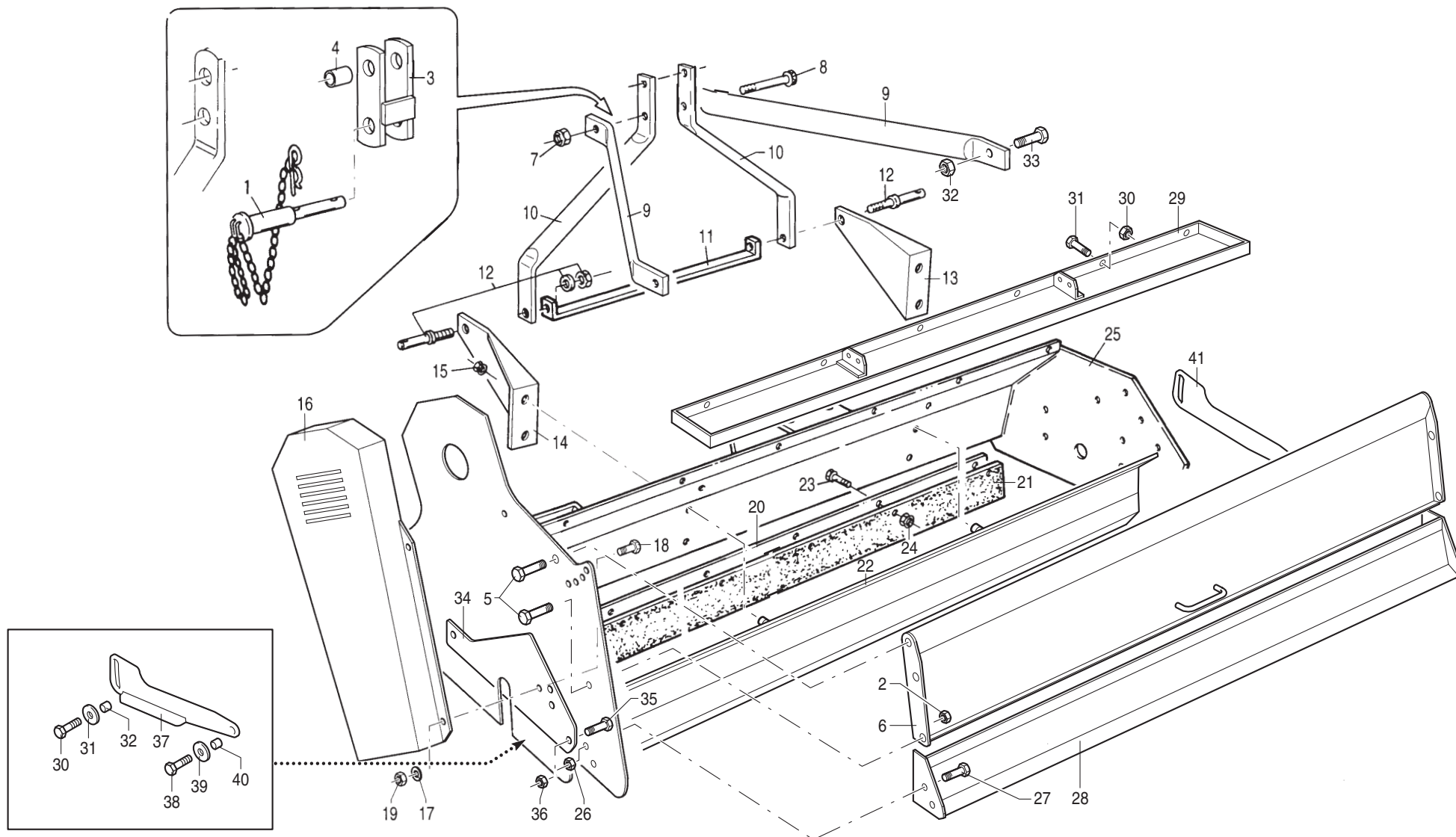

MURATORI MT 20 H

TAV. 1.0

POS.	N°	CODICE Q.	DESCRIZIONE	DESIGNATION	BENENNUNG	DESCRIPTION	DESIGNAZIONE	Da matr.	Fino matr.
								De nr. serie Vom Seriennr. From serial nr.	Jusqu'au nr. serie Bis Seriennr. Up to serial nr.
21	68068000	1	BANDELLA	BANDE	BAND	STRAP	155		
22	40266700	1	RINFORZO	RENFORT	VERSTAERKUNG	REINFORCEMENT	105		
22	40266800	1	RINFORZO	RENFORT	VERSTAERKUNG	REINFORCEMENT	130		
22	40266900	1	RINFORZO	RENFORT	VERSTAERKUNG	REINFORCEMENT	155		
23	60022800		VITE	VIS	SCHRAUBE	SCREW	TE 8 x 20 UNI 5739		
24	62010200		DADO	ECROU	MUTTER	NUT	M 8 x 1,25 AUTOBLOCC.		
25	41116600	1	TELAIO	CHASSIS	RAHMEN	FRAME	105		
25	41116700	1	TELAIO	CHASSIS	RAHMEN	FRAME	130		
25	41116800	1	TELAIO	CHASSIS	RAHMEN	FRAME	155		
26	62010600	1	DADO	ECROU	MUTTER	NUT	M 12 x 1,75 AUTOBLOCC.		
27	60001400	1	VITE	VIS	SCHRAUBE	SCREW	TE 12 x 25 UNI 5739		
28	40267500	1	CHIUSURA	FERMETURE	VERSCHLUSS	GRIPPING			
28	40267600	1	CHIUSURA	FERMETURE	VERSCHLUSS	GRIPPING			
28	40267700	1	CHIUSURA	FERMETURE	VERSCHLUSS	GRIPPING			
29	40267100	1	CHIUSURA	FERMETURE	VERSCHLUSS	GRIPPING			
29	40267200	1	CHIUSURA	FERMETURE	VERSCHLUSS	GRIPPING			
29	40267300	1	CHIUSURA	FERMETURE	VERSCHLUSS	GRIPPING			
30	62010400	4	DADO	ECROU	MUTTER	NUT	M 10 x 1,5 AUTOBLOCC.		
31	60004000	4	VITE	VIS	SCHRAUBE	SCREW	TE 10 x 20 UNI 5739		
32	62010600	2	DADO	ECROU	MUTTER	NUT	M 12 x 1,75 AUTOBLOCC.		
33	60023000	2	VITE	VIS	SCHRAUBE	SCREW	TE 12 x 30 UNI 5739		
34	39285200	1	CHIUSURA	FERMETURE	VERSCHLUSS	GRIPPING			
35	60002200	2	VITE	VIS	SCHRAUBE	SCREW	TE 12x 20 UNI 5739		
36	62010600	2	DADO	ECROU	MUTTER	NUT	M 12 x 1,75 AUTOBLOCC.		
37	39357900	1	BANDELLA	BANDE	BAND	STRAP			
38	60021300	4	VITE	VIS	SCHRAUBE	SCREW	TE 10 x 30 UNI 5739		

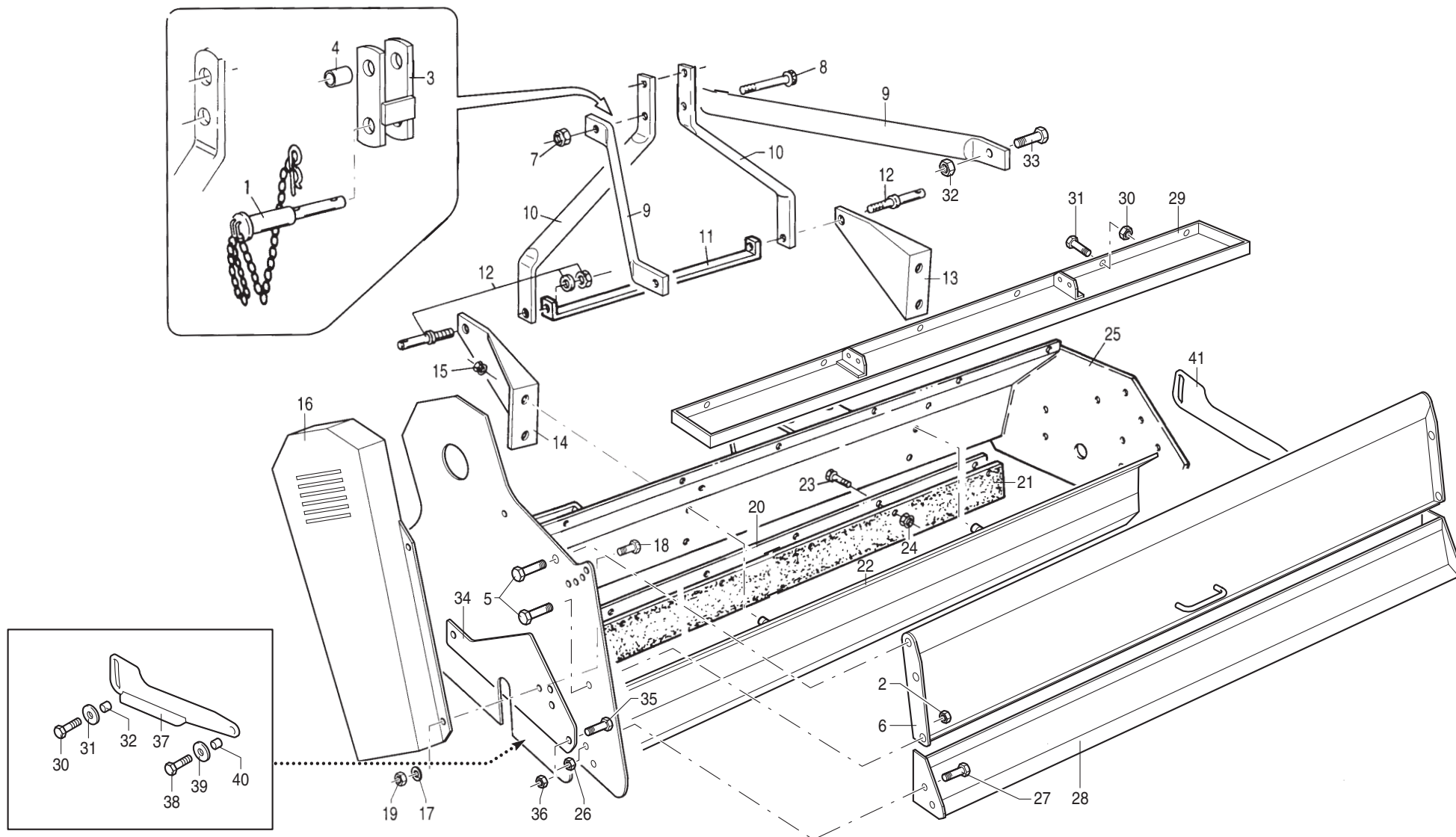

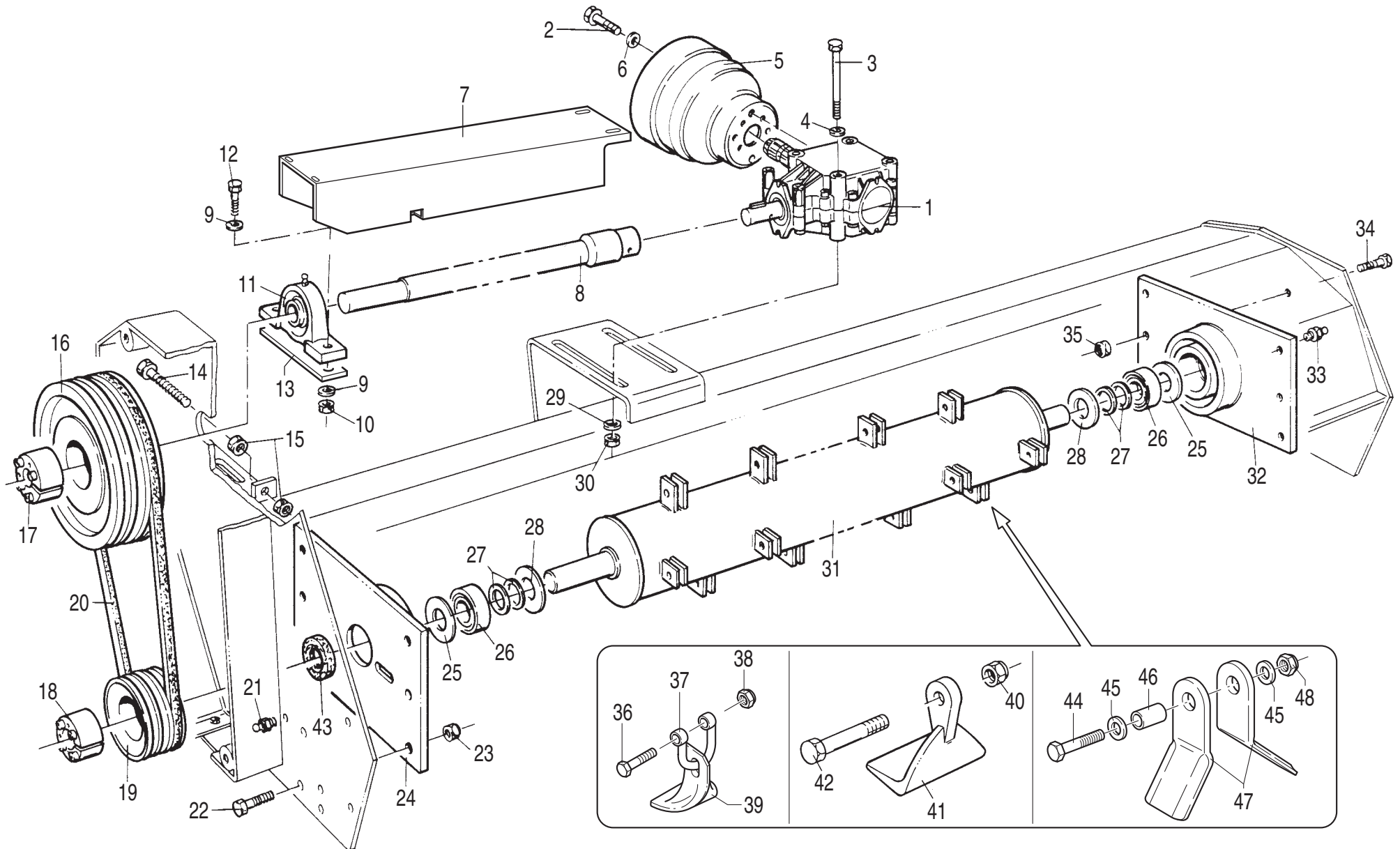

MURATORI MT 20 H

TAV. 2.0

POS.	N°	CODICE Q.	DESCRIZIONE	DESIGNATION	BENENNUNG	DESCRIPTION	DESIGNAZIONE	Da matr.	Fino matr.
								De nr. serie Vom Seriennr. From serial nr.	Jusqu'au nr. serie Bis Seriennr. Up to serial nr.
1	46038800	1	MOLTIPLICATORE	BOITIER	GETRIEBE	GEAR BOX			
2	60024800	2	VITE	VIS	SCHRAUBE	SCREW	TE 6 x 16 UNI 5739		
3	60025600	4	VITE	VIS	SCHRAUBE	SCREW	TE 10 x 130 UNI 5737		
4	61004900	3	RONDELLA	RONDELLE	SCHEIBE	WASHER	PIANA Ø 10 UNI 6592		
5	68074300	1	PROTEZIONE	PROTECTION	SCHUTZ	GUARD			
6	61006000	2	RONDELLA	RONDELLE	SCHEIBE	WASHER	PIANA Ø 6 FASCIA LARGA		
7	40265801	1	PROTEZIONE	PROTECTION	SCHUTZ	GUARD	105		
7	40265901	1	PROTEZIONE	PROTECTION	SCHUTZ	GUARD	130		
7	40266001	1	PROTEZIONE	PROTECTION	SCHUTZ	GUARD	155		
8	40228501	1	PROLUNGA	RALLONGE	VERLAENGERUNGSROHR	EXTENSION	105		
8	40228601	1	PROLUNGA	RALLONGE	VERLAENGERUNGSROHR	EXTENSION	130		
8	40228701	1	PROLUNGA	RALLONGE	VERLAENGERUNGSROHR	EXTENSION	155		
9	61005000	3	RONDELLA	RONDELLE	SCHEIBE	WASHER	PIANA Ø 12 UNI 6592		
10	62010600	2	DADO	ECROU	MUTTER	NUT	M 12 x 1,75 AUTOBLOCC.		
11	67012600	1	SUPPORTO	SUPPORT	TRAEGER	SUPPORT	UCP 205		
12	60028100	2	VITE	VIS	SCHRAUBE	SCREW	TE 12 x 55 UNI 5739		
13	30199800	1	SPESSORE	EPAISSEUR	DISTANZRING	SPACER			
14	40161400	1	TIRANTE	TIRANT	STANGE	TIEROD			
15	62007000	2	DADO	ECROU	MUTTER	NUT	M 10 x 1,5 UNI 5588		
16	68059100	1	PULEGGIA	POULIE	RIEMENSCHIEBE	PULLEY	Ø 225 3 SPA		
17	68058900	1	CALETTATORE	DISPOSITIF D'ASSEMBLAGE	SPANNSATZ	LOCKING DEVICE	Øi 25 Øe 55		
18	68059000	1	CALETTATORE	DISPOSITIF D'ASSEMBLAGE	SPANNSATZ	LOCKING DEVICE	Øi 35 Øe 55		
19	68074100	1	PULEGGIA	POULIE	RIEMENSCHIEBE	PULLEY	Ø 90 3 SPA		
20	68085200	3	CINGHIA	COURROIE	KEILRIEMEN	BELT	A 45		
21	64000200	1	INGRASSATORE	GRAISSEUR	SCHMIERNIPPEL	GREASE FITTING	M 6 x 1		
22	60020400	4	VITE	VIS	SCHRAUBE	SCREW	TE 12 x 25 UNI 5735		

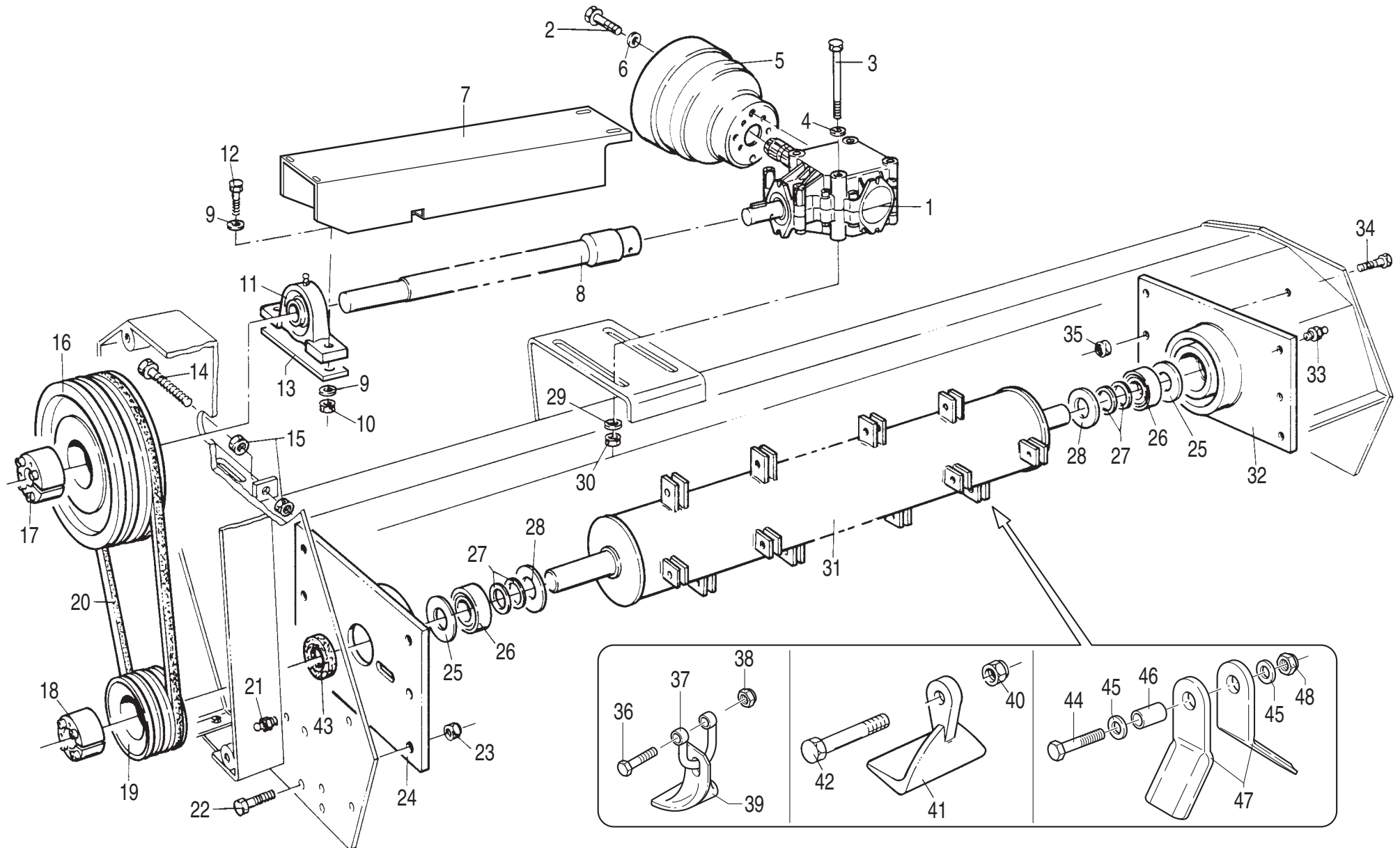

MURATORI MT 20 H

TAV. 2.0

POS.	N°	CODICE Q.	DESCRIZIONE	DESIGNATION	BENENNUNG	DESCRIPTION	DESIGNAZIONE	Da matr.	Fino matr.
								De nr. serie Vom Seriennr. From serial nr.	Jusqu'au nr. serie Bis Seriennr. Up to serial nr.
23	62010600	4	DADO	ECROU	MUTTER	NUT	M 12 x 1,75 AUTOBLOCC.		
24	40228000	1	SUPPORTO SX	SUPPORT (G)	TRAEGER (LINKS)	SUPPORT (LH)			
25	32068000	2	SPESSORE	EPAISSEUR	DICKE	THICKNESS			
26	67012900	2	CUSCINETTO	ROULEMENT	LAGER	BEARING	1306		
27	68068800		SPESSORE	EPAISSEUR	DISTANZRING	SPACER	42 x 30 x 1		
28	39091100	2	DISCO	DISQUE	SCHEIBE	DISC	Øe 70 Øi 30 sp. 1,5		
29	61004900	4	RONDELLA	RONDELLE	SCHEIBE	WASHER	PIANA Ø 10 UNI 6592		
30	62010400	4	DADO	ECROU	MUTTER	NUT	M 10 x 1,5 AUTOBLOCC.		
31	42045400	1	ROTORE	ROTOR	ROTOR	ROTOR	105		
31	42045500	1	ROTORE	ROTOR	ROTOR	ROTOR	130		
31	42045600	1	ROTORE	ROTOR	ROTOR	ROTOR	155		
32	40084600	1	SUPPORTO DX	SUPPORT (D)	TRAEGER (RECHTS)	SUPPORT (RH)			
33	64001800	1	INGRASSATORE	GRAISSEUR	SCHMIERNIPPEL	GREASE FITTING	M 10 x 1 DIRITTO		
34	60020400	6	VITE	VIS	SCHRAUBE	SCREW	TE 12 x 25 UNI 5739		
35	62010600		DADO	ECROU	MUTTER	NUT	M 12 x 1,75 AUTOBLOCC.		
36	60007700		VITE	VIS	SCHRAUBE	SCREW	TE 14 x 70 UNI 5737		
36	60023300	2	VITE	VIS	SCHRAUBE	SCREW	TE 14 x 60 UNI 5737		
37	68074000		CAVALLOTTO	ARRETOIR	KLEMMSTUECK	UBOLT			
38	62010800		DADO	ECROU	MUTTER	NUT	M 14 x 2 AUTOBLOCC.		
39	12015100		COLTELLO A SPATOLE	COUTEAU	MESSER	KNIFE			
40	62010800		DADO	ECROU	MUTTER	NUT	M 14 x 2 AUTOBLOCC.		
41	12019400		MAZZA	MARTEAUX	HAMMER	HAMMER			
42	60007100		VITE	VIS	SCHRAUBE	SCREW	TE 14 x 50 UNI 5737		
43	66014000		ANELLO TENUTA	JOINT D'ETANCHEITE	DICHTUNGSRING	JUNT RING	30 x 40 x 4		
44	60012900		VITE	VIS	SCHRAUBE	SCREW	TE 8 x 45 UNI 5737		
45	61006200		RONDELLA	RONDELLE	SCHEIBE	WASHER	PIANA Ø 9		

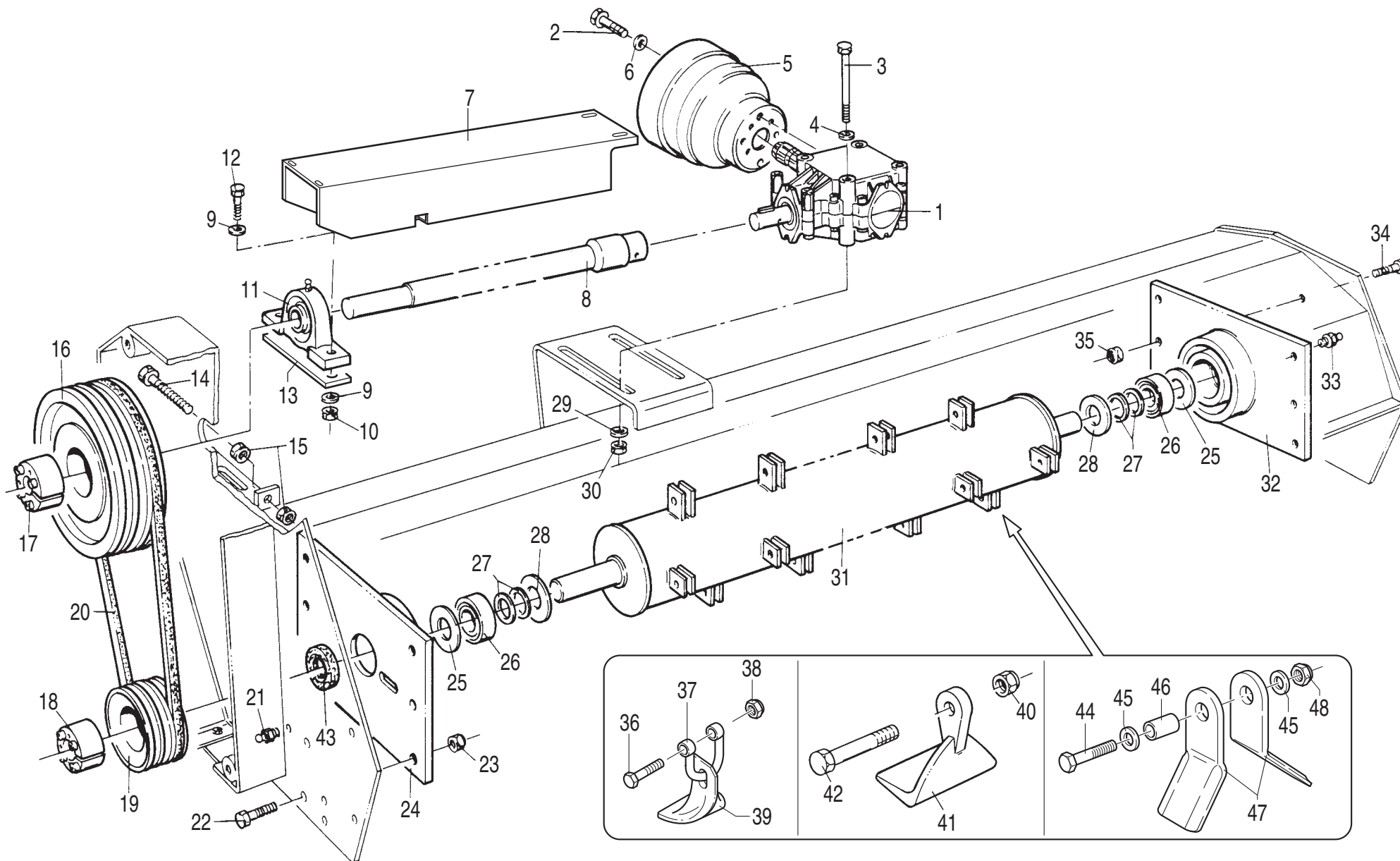

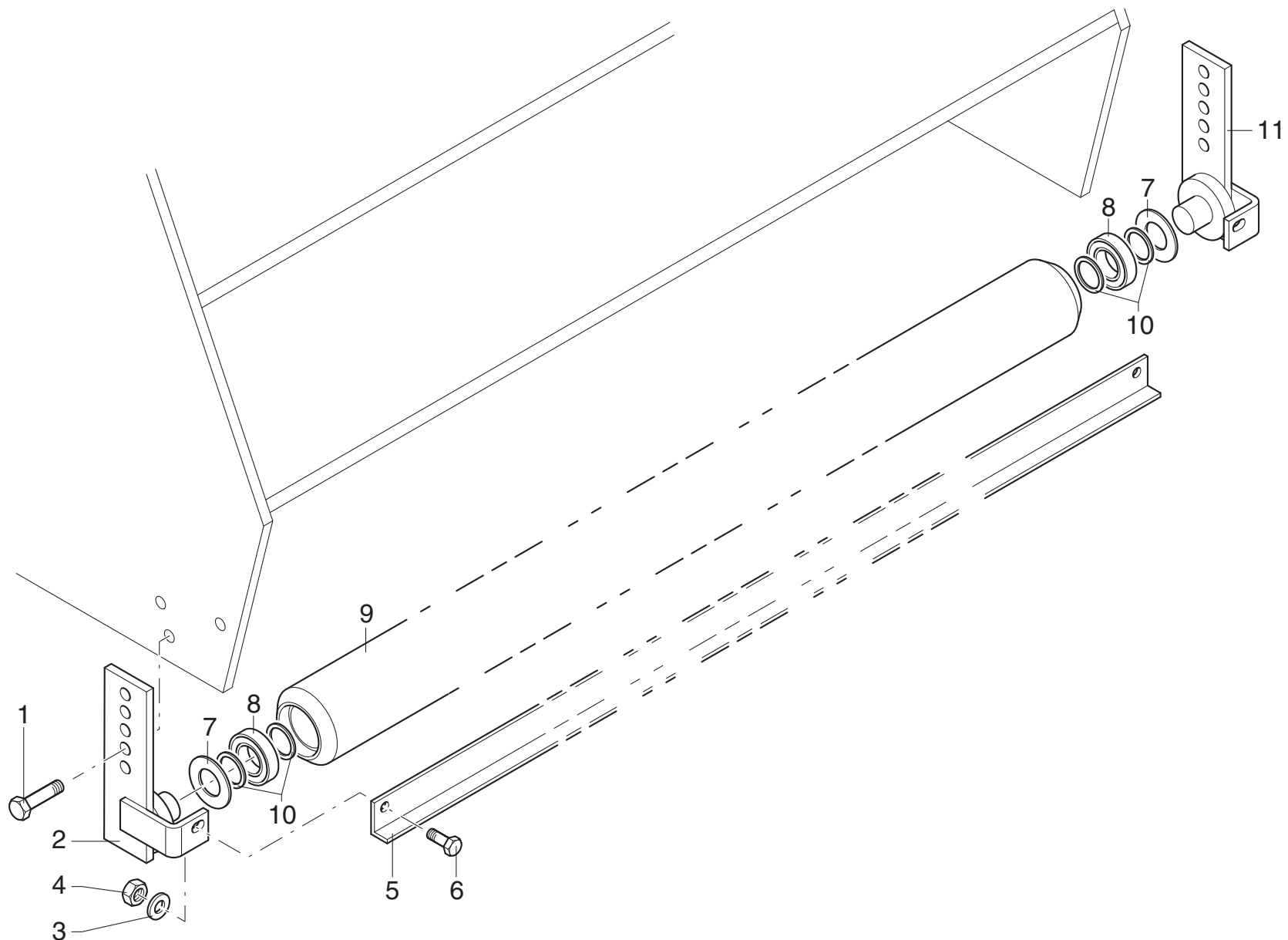

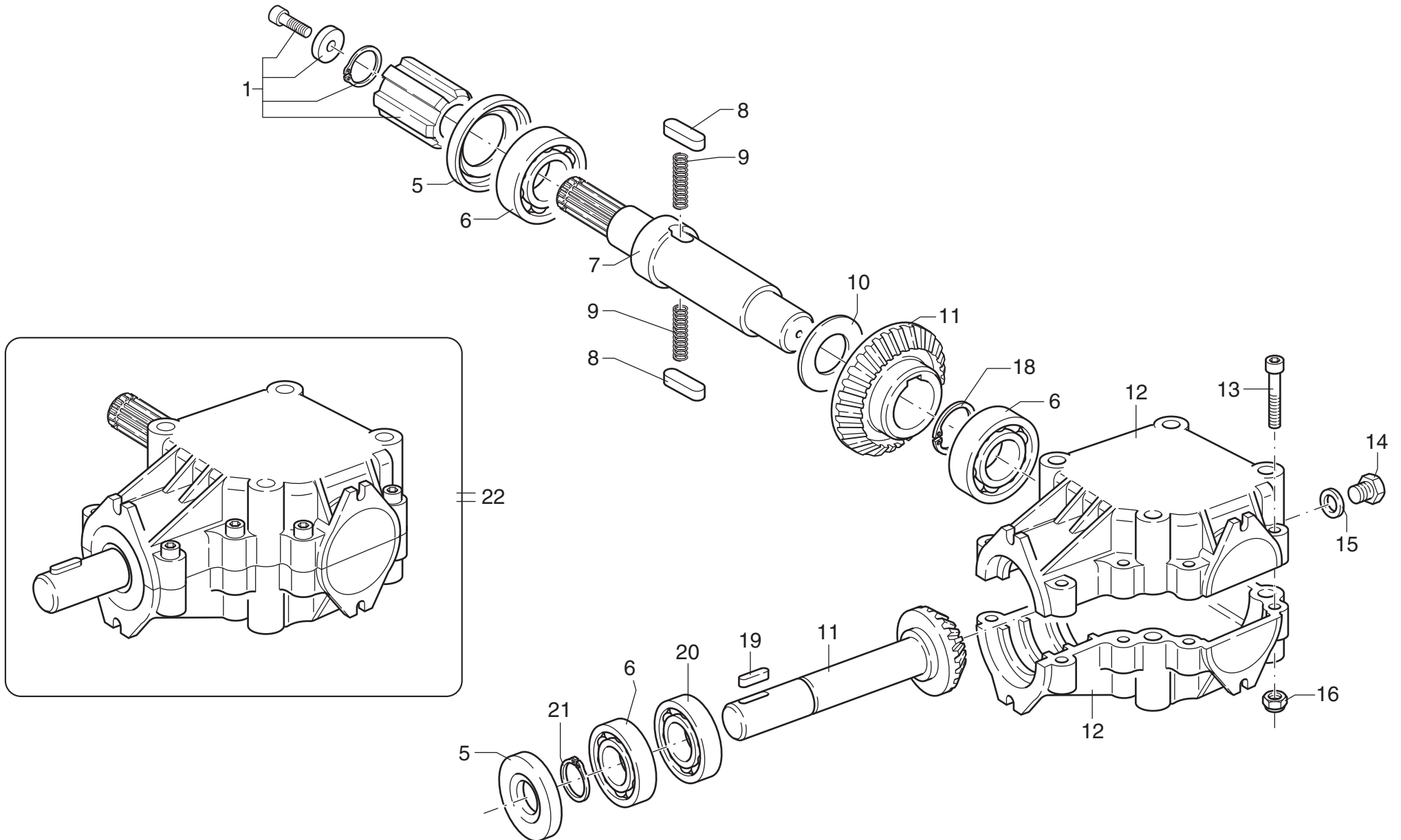

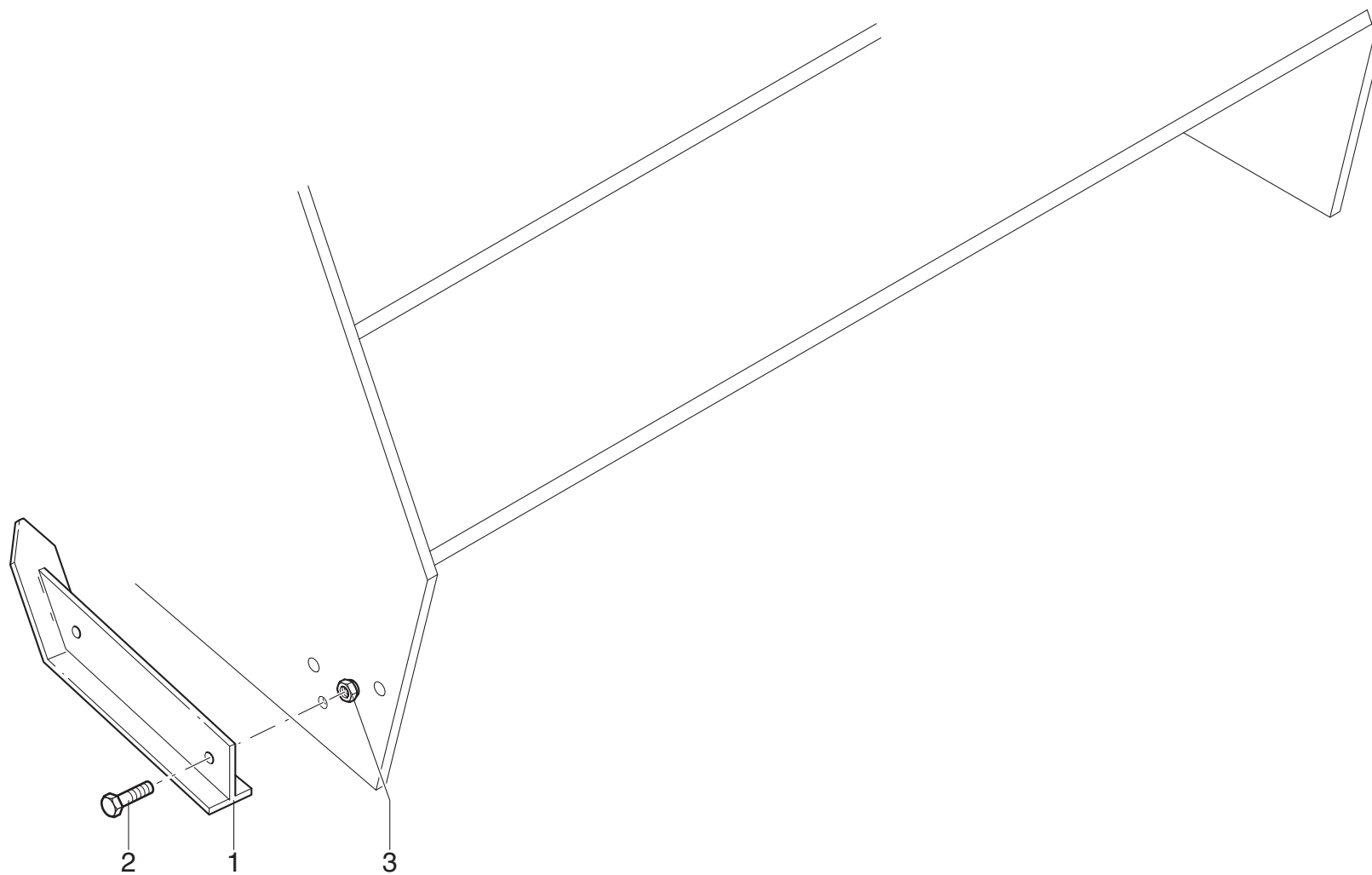

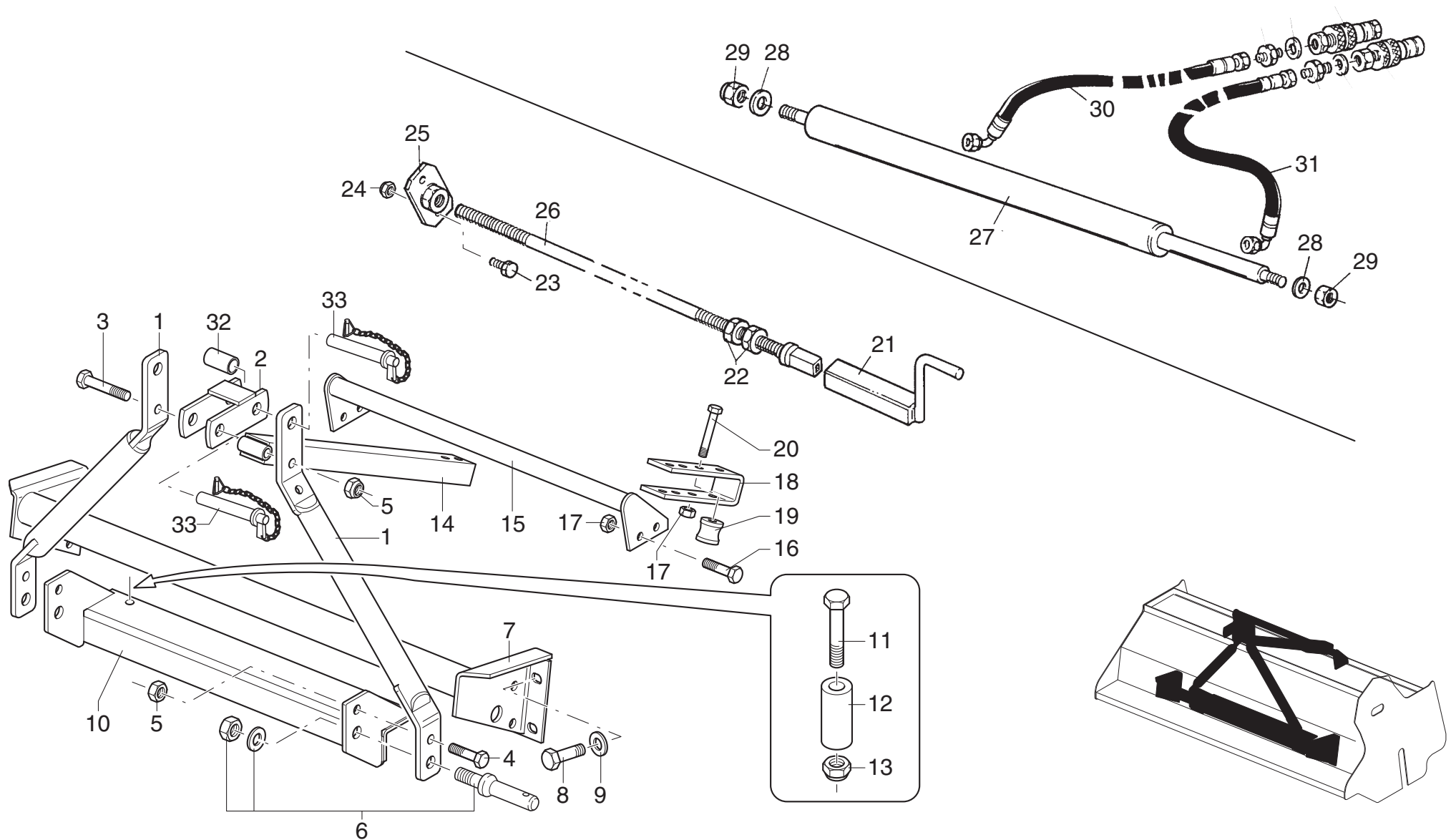

MURATORI MT 20 H

TAV. 6.0

POS.	N°	CODICE Q.	DESCRIZIONE	DESIGNATION	BENENNUNG	DESCRIPTION	DESIGNAZIONE	Da matr.	Fino matr.
								De nr. serie Vom Seriennr. From serial nr.	Jusqu'au nr. serie Bis Seriennr. Up to serial nr.
1	32183600	2	TIRANTE	TIRANT	STANGE	TIEROD			
2	40237800	1	STAFFA	BRIDE	BUEGEL	BRACKET			
3	60011900	1	VITE	VIS	SCHRAUBE	SCREW	TE 12 x 120 UNI 5737		
4	60021200	2	VITE	VIS	SCHRAUBE	SCREW	TE 12 x 35 UNI 5739		
5	62010600	3	DADO	ECROU	MUTTER	NUT	M 12 x 1,75 AUTOBLOCC.		
6	68062500	2	PERNO	PIVOT	BOLZEN	PIN			
7	40267800	1	TELAIO	CHASSIS	RAHMEN	FRAME			
8	60023000	4	VITE	VIS	SCHRAUBE	SCREW	TE 12 x 30 UNI 5739		
9	61005000	4	RONDELLA	RONDELLE	SCHEIBE	WASHER	PIANA Ø 12 UNI 6592		
10	40267900	1	CARRELLO	CHARIOT	WAGEN	CAR			
11	60021500	2	VITE	VIS	SCHRAUBE	SCREW	TE 12 x 80 UNI 5737		
12	32183700	2	DISTANZIALE	ENTRETOISE	DISTANZSTUECK	SPACER			
13	62010600	2	DADO	ECROU	MUTTER	NUT	M 12 x 1,75 AUTOBLOCC.		
14	40268100	1	TIRANTE	TIRANT	STANGE	TIEROD			
15	40268000	1	SOSTEGNO	SUPPORT	TRAEGER	SUPPORT			
16	60023000	4	VITE	VIS	SCHRAUBE	SCREW	TE 12 x 30 UNI 5739		
17	62010600	8	DADO	ECROU	MUTTER	NUT	M 12 x 1,75 AUTOBLOCC.		
18	30113600	1	STAFFA	BRIDE	BUEGEL	BRACKET			
19	38018500	2	RULLINO	GALET	ROLLE	NEEDLE PIN			
20	60024400	4	VITE	VIS	SCHRAUBE	SCREW	TE 12 x 70 UNI 5737		
21	40121700	1	MANOVELLA	MANIVELLE	KURBEL	CRANK			
22	62014700	2	CHIOCCIOLA	ECROU EN CARACOLE	MUTTERSCHLOSS	LEAD NUT			
23	60036200	2	VITE	VIS	SCHRAUBE	SCREW	TE 8 x 35 UNI 5739		
24	62010200	2	DADO	ECROU	MUTTER	NUT	M 8 x 1,25 AUTOBLOCC.		
25	40246800	1	CHIOCCIOLA	ECROU EN CARACOLE	MUTTERSCHLOSS	LEAD NUT			
26	40247000	1	VITE	VIS	SCHRAUBE	SCREW			

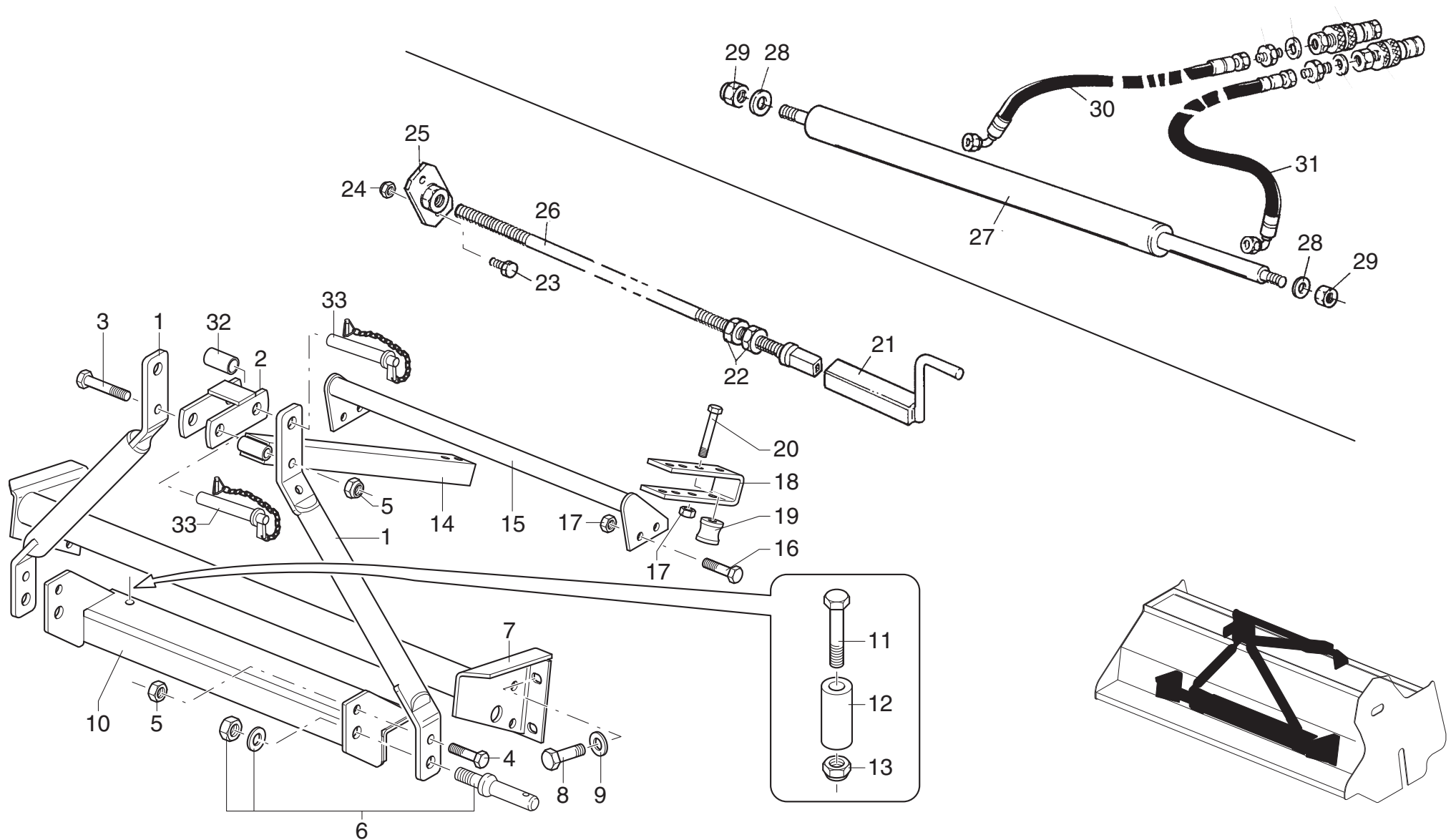

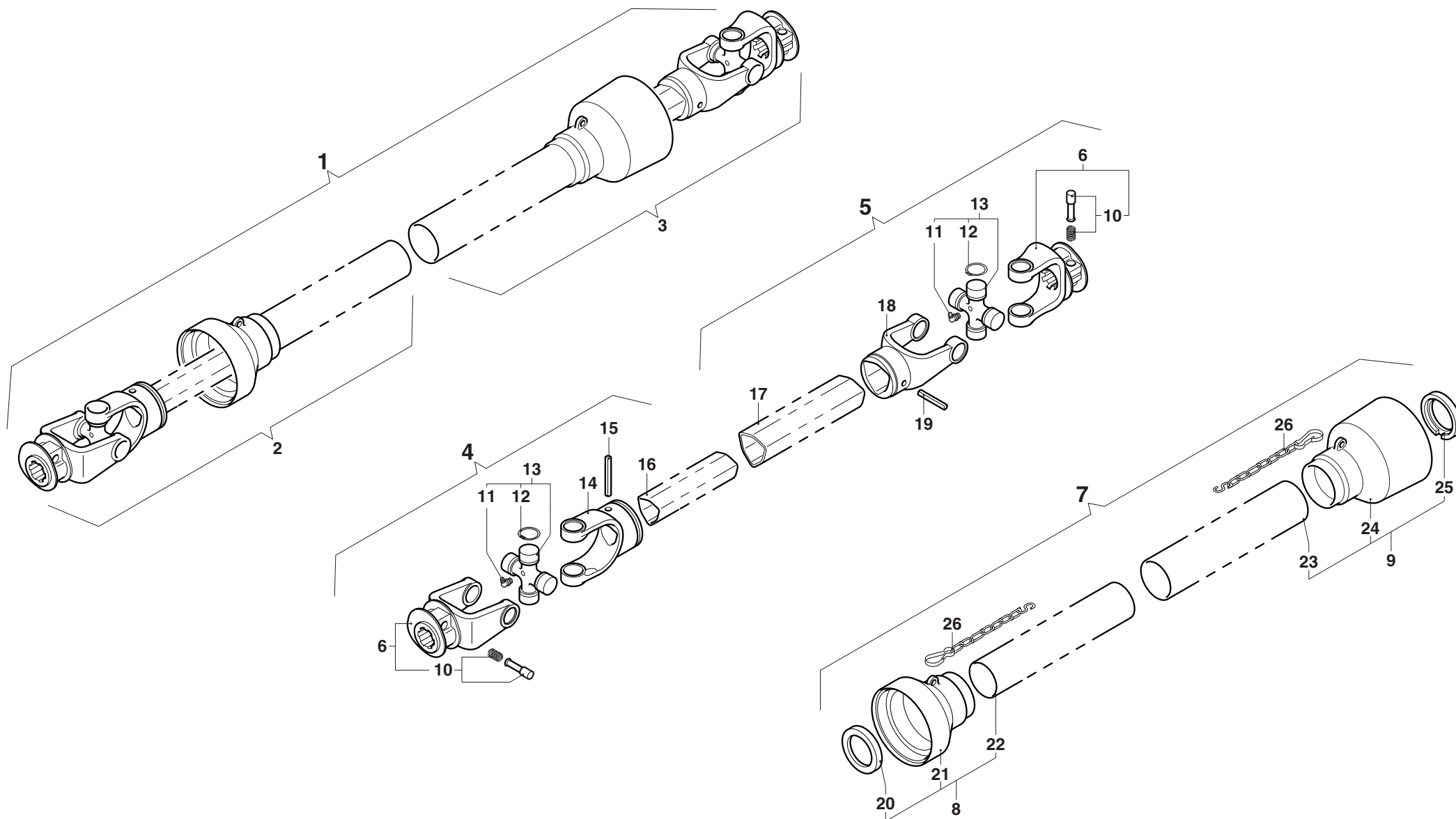

MURATORI MT 20 H

TAV. 7.0

POS.	N°	CODICE Q.	DESCRIZIONE	DESIGNATION	BENENNUNG	DESCRIPTION	DESIGNAZIONE	Da matr.	Fino matr.
								De nr. serie Vom Seriennr. From serial nr.	Jusqu'au nr. serie Bis Seriennr. Up to serial nr.
1	AB207SF	1	ALBERO CARDANICO COMPLETO	ARBRE A JOINTS DE CARDAN	KARDANWELLE	PTO SHAFT			
2	B2070B1	1	SEMIALBERO INTERNO	DEMI-ARBRE INTERIEUR	INNENHALBWELLE	INTERNAL HALF SHAFT			
3	B2070B2	1	SEMIALBERO ESTERNO	DEMI-ARBRE EXTERIEUR	AUSSENHALBWELLE	EXTERNAL HALF SHAFT			
4	B207001	1	SEMIALBERO INTERNO	DEMI-ARBRE INTERIEUR	INNENHALBWELLE	INTERNAL HALF SHAFT			
5	B2070002	1	SEMIALBERO ESTERNO	DEMI-ARBRE EXTERIEUR	AUSSENHALBWELLE	EXTERNAL HALF SHAFT			
6	0800203	2	FORCELLA	FOURCHE	GABEL	YOKE			
7	083B02070	1	PROTEZIONE	PROTECTION	SCHUTZ	GUARD			
8	083B020701	1	PROTEZIONE INTERNA	PROTECTION INTERIEURE	INNENSCHUTZ	INTERNAL GUARD			
9	083B020702	1	PROTEZIONE ESTERNA	PROTECTION EXTERIEURE	AUSSENSCHUTZ	EXTERNAL GUARD			
10	0986014047	2	PULSANTE	BOUTON	DRUCKKNOPF	PUSH BOTTON			
11	09840081002	2	INGRASSATORE	GRAISSEUR	SCHMIERNIPPEL	GREASE FITTING			
12	098020224	8	ANELLO ELASTICO	ARRETOIR	SPANNRING	SNAP-RING			
13	08202	2	CROCIERA	CROISILLON	KREUZSTUECK	SPIDER			
14	08002011	1	FORCELLA	FOURCHE	GABEL	YOKE			
15	098700850	1	SPINA ELASTICA	GOUPILLE ELASTIQUE	SPANNSTIFT	ELASTIC PIN			
16	09881294100	1	TUBO INTERNO	TUBE INTERIEUR	INNENROHR	INTERNAL TUBE			
17	09881363100	1	TUBO ESTERNO	TUBE EXTERIEUR	AUSSENROHR	EXTERNAL TUBE			
18	08002021	1	FORCELLA	FOURCHE	GABEL	YOKE			
19	098700855	1	SPINA ELASTICA	GOUPILLE ELASTIQUE	SPANNSTIFT	ELASTIC PIN			
20	0265220008	1	GHIERA	FRETTE	NUTMUTTER	RING NUT			
21	0256010425	1	CUFFIA	CAPOUCHON	HAUBE	GUARD			
22	0988955B2070	1	TUBO INTERNO	TUBE INTERIEUR	INNENROHR	INTERNAL TUBE			
23	0988961B2070	1	TUBO ESTERNO	TUBE EXTERIEUR	AUSSENROHR	EXTERNAL TUBE			
24	0256010424	1	CUFFIA	CAPOUCHON	HAUBE	GUARD			
25	0265220007	1	GHIERA	FRETTE	NUTMUTTER	RING NUT			

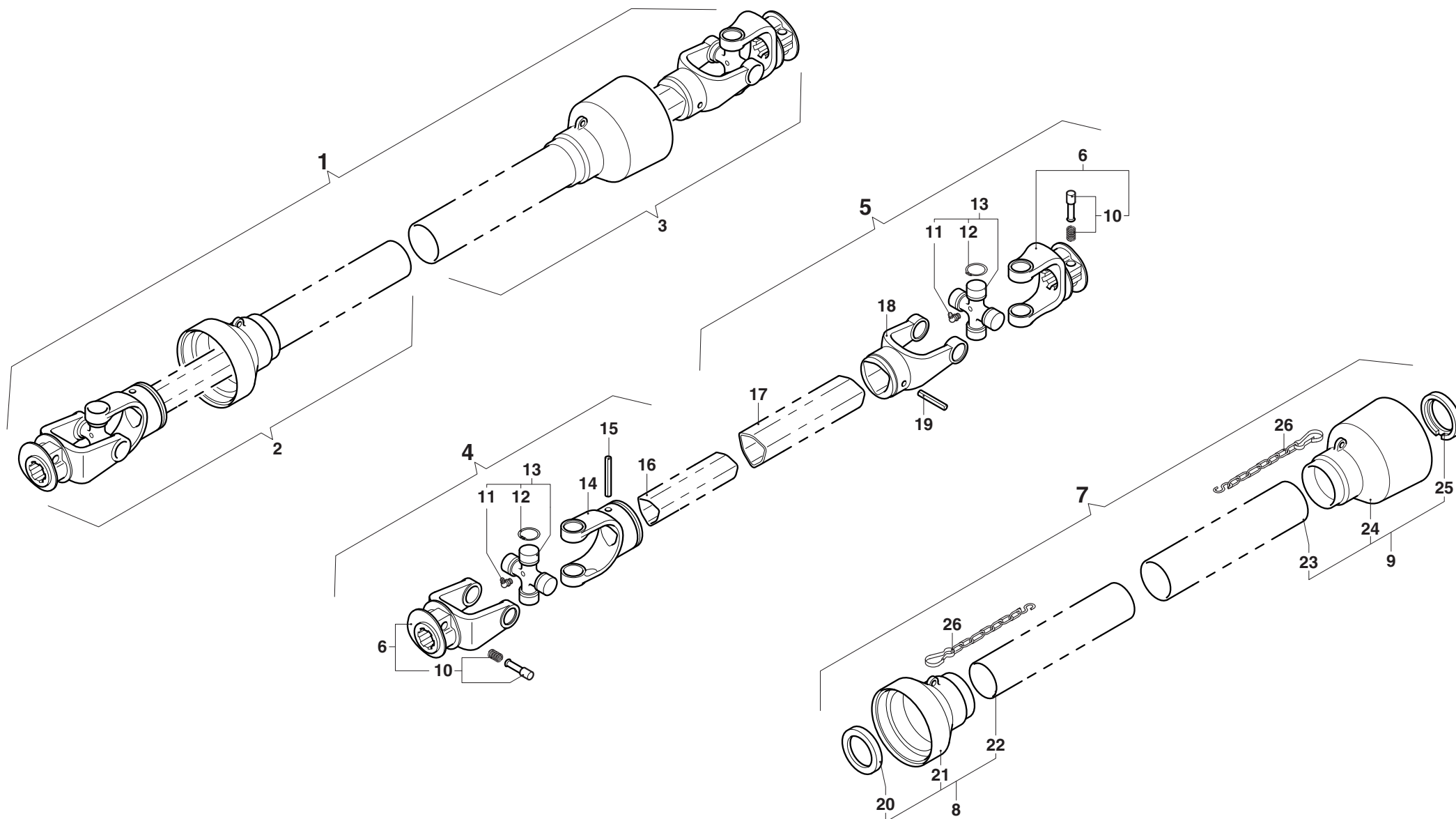



MURATORI S.p.A.

Via Pavarello, 21 - 41051 Castelnuovo Rangone (MO) Italy - Tel. 059.5330611 Fax 059.537259

www.muratoriequip.it *info@muratoriequip.it*

Capitale sociale Euro 480.000 interamente versato

Registro Imprese di Modena

Codice fiscale e numero d'iscrizione: 00708860366