



MURATORI

**TIPO-TYPE-TYP
MT 29**

CATALOGO RICAMBI
Catalogue Pièces Detachées
Ersatzteilkatalog
Spare Parts Catalogue
Catálogo Recambios

EDIZIONE 03/2023

Per ordinare parti di ricambio specificare:

- tipo e matricola della macchina (apposti sulla macchina o sui documenti di acquisto);
- numero del riferimento del pezzo nel disegno (Pos.), numero della tavola (Tav.) e numero di codice

N.B.: le indicazioni destro o sinistro vengono date guardando la macchina da dietro.

Pour les commandes de pièces de rechange veuillez spécifier:

- type et numéro de serie de la machine (indiqués sur la machine et sur le bon d'achat);
- numéro de référence du pièce sur le plan (Pos.), numéro du plan (Tav.) et numéro de code (codice)

N.B.: les indications droite ou gauche sont données en regardant la machine par derrière.

Zum Bestellen von Ersatzteilen folgendes angeben:

- Typ und Serien-Nr. der Maschine (zu finden auf der Maschine oder der Einkaufspapieren);
- Bezug-Nr. des Ersatzteils auf der Zeichnung (Pos.), Zeichnungsnummer (Tav.) und Kodenummer (codice)

N.B.: die Angaben rechts und links verstehen sich so, dass man hinter der Maschine steht.

When ordering spare parts specify:

- machine type and serial number (found on the machine or on the purchasing documents);
- reference number of the part on the relative drawing (Pos.), number of the drawing (Tav.) and part number (codice)

N.B.: right-hand or left-hand indications are made by viewing the machine from the rear.

TAV. 1.0

GRUPPO TELAIO
ENSEMBLE CHASSIS
SATZ FÜR RAHMEN
KIT FOR FRAME

TAV. 2.0

GRUPPO TRASMISSIONE ROTORE
ENSEMBLE TRANSMISSION ROTORS
SATZ FÜR DEN ROTARONTRIEB
KIT FOR THE ROTOR TRANSMISSION

TAV. 3.0

GRUPPO RULLO POSTERIORE
ENSEMBLE ROULEAU ARRIERE
SATZ HINTERE WALZE
KIT REAR ROLLER

TAV. 4.0

GRUPPO MOLTIPLICATORE
ENSEMBLE MOLTIPLICATEUR
SATZ FÜR GETRIEBE
KIT FOR GEAR BOX

TAV. 5.0

ACCESSORI A COMPLETAMENTO - RUOTA
OPTIONS D'ACHEVEMENT - ROUE
ZUBEHÖRE ZUR ERGANZUNG DER MASCHINE - RAD
CHOICE OF EQUIPMENT COMPLETING MACHINE - WHEEL

TAV. 6.0

ALBERO CARDANICO COMPLETO - AB207SF
ARBRE A JOINTS DE CARDAN - AB207SF
KARDANWELLE - AB207SF
PTO SHAFT - AB207SF

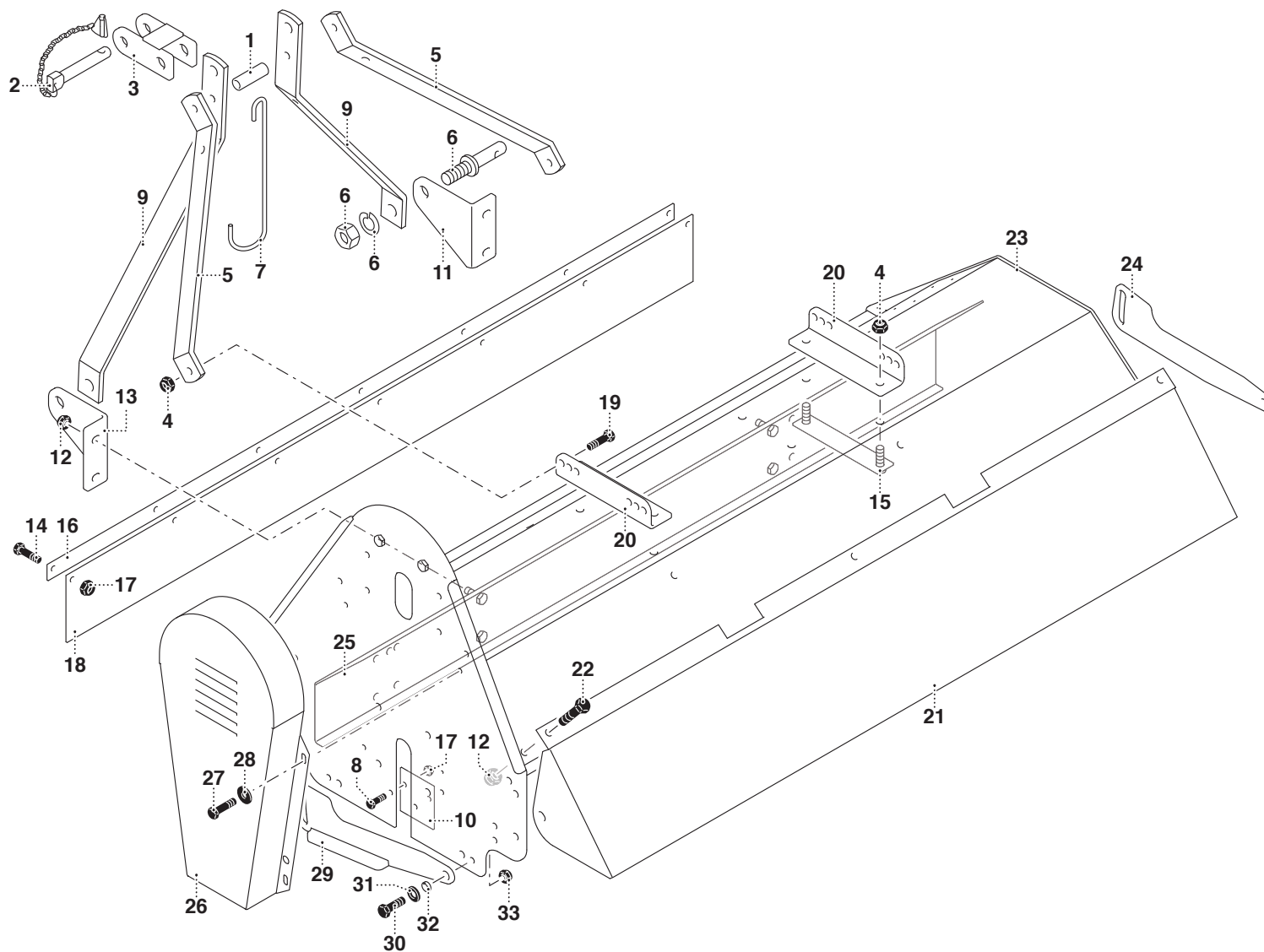

MURATORI MT 29

TAV. 1.0

POS.	N° CODICE	Q.	DESCRIZIONE	DESIGNATION	BENENNUNG	DESCRIPTION	DESIGNAZIONE	Da matr. De nr. serie Vom Seriennr. From serial nr.	Fino matr. Jusqu'au nr. serie Bis Seriennr. Up to serial nr.
1	32021400	1	BOCCOLA	DOUILLE	BUCHSE	BUSHING			
2	38019200	1	PERNO	PIVOT	BOLZEN	PIN			
3	40237800	1	ATTACCO	ATTACHE	ANSCHLUSS	ATTACHMENT			
4	62010600		DADO	ECROU	MUTTER	NUT	M12 CONELOCK		
5	30178900	2	TIRANTE	TIRANT	STANGE	TIEROD			
6	68062500	2	PERNO	PIVOT	BOLZEN	PIN			
7	38024500	1	GANCIO	CROCHET	HAKEN	HOOK			
8	60015100	2	VITE	VIS	SCHRAUBE	SCREW	TE M8x16 ZNT 5739		
9	30178800	2	TIRANTE	TIRANT	STANGE	TIEROD			
10	39387400	1	CHIUSURA SX	FERMATURE (G)	VERSCHLUSS (L)	LOCK (LH)			
11	39251600	1	MENSOLA DX	CONSOLE (D)	KONSOLE (R)	BRACKET (RH)			
12	62010600		DADO	ECROU	MUTTER	NUT	M12 CONELOCK		
13	39251500	1	MENSOLA SX	CONSOLE (G)	KONSOLE (L)	BRACKET (LH)			
14	60026900		VITE	VIS	SCHRAUBE	SCREW	TE M8x25 ZNT 5739		
15	40231700	2	CONTROPIASTRA	CONTRE-PLAQUE	GEGENPLATTE	COUNTER PLATE			
16	30125500	1	ATTACCO	ATTACHE	ANSCHLUSS	ATTACHMENT	105		
16	30125600	1	ATTACCO	ATTACHE	ANSCHLUSS	ATTACHMENT	130		
16	30125700	1	ATTACCO	ATTACHE	ANSCHLUSS	ATTACHMENT	155		
16	30204000	1	ATTACCO	ATTACHE	ANSCHLUSS	ATTACHMENT	180		
17	62010200		DADO	ECROU	MUTTER	NUT	M8 CONELOK		
18	68067800	1	BANDELLA	BANDE	BAND	STRAP	105		
18	68067900	1	BANDELLA	BANDE	BAND	STRAP	130		
18	68068000	1	BANDELLA	BANDE	BAND	STRAP	155		
18	68103400	1	BANDELLA	BANDE	BAND	STRAP	180		
19	60023000	2	VITE	VIS	SCHRAUBE	SCREW	M12X30 ZNT UNI5739		
20	39386300	2	STAFFA	BRIDE	BÜGEL	BRACKET			

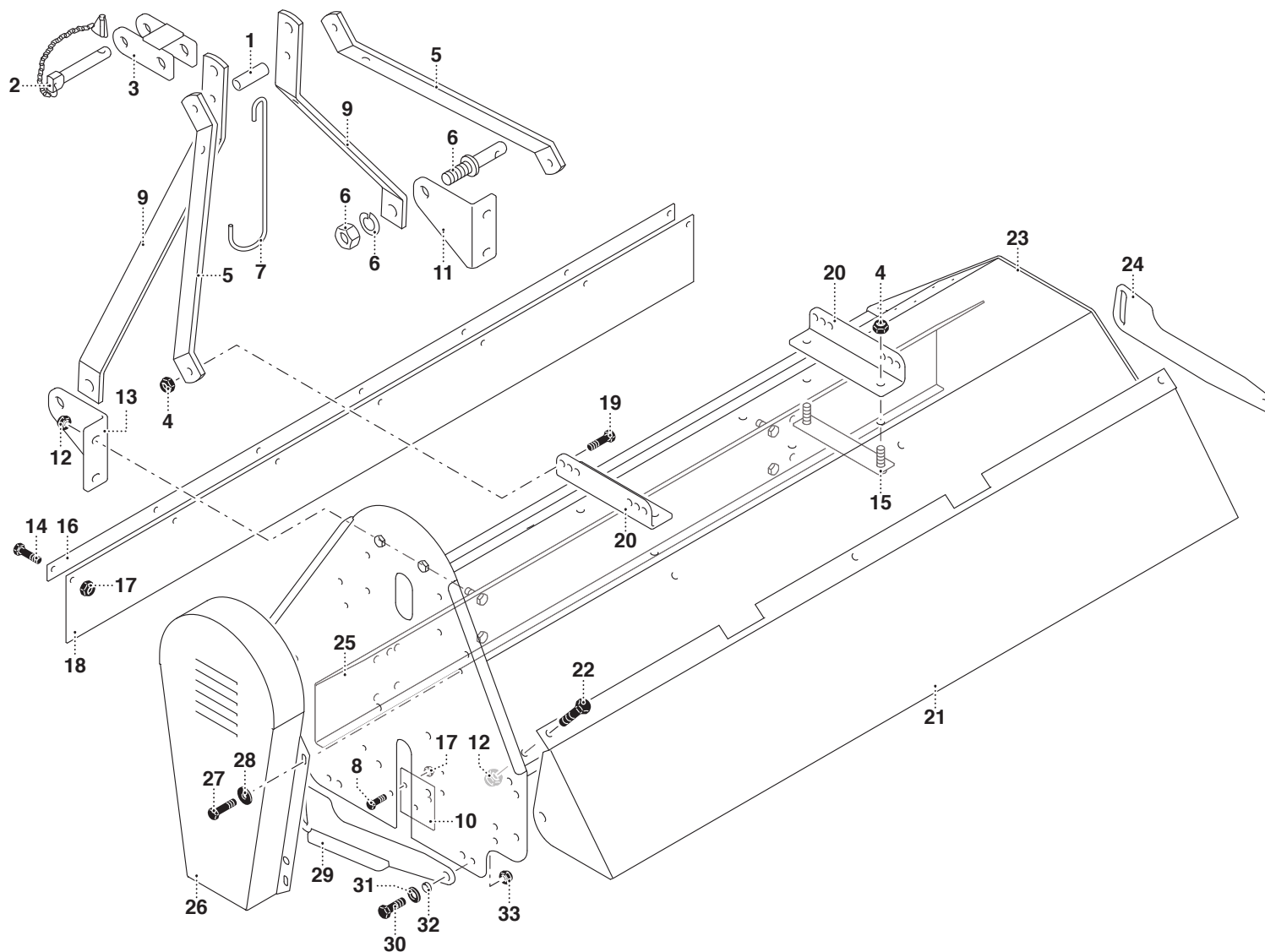

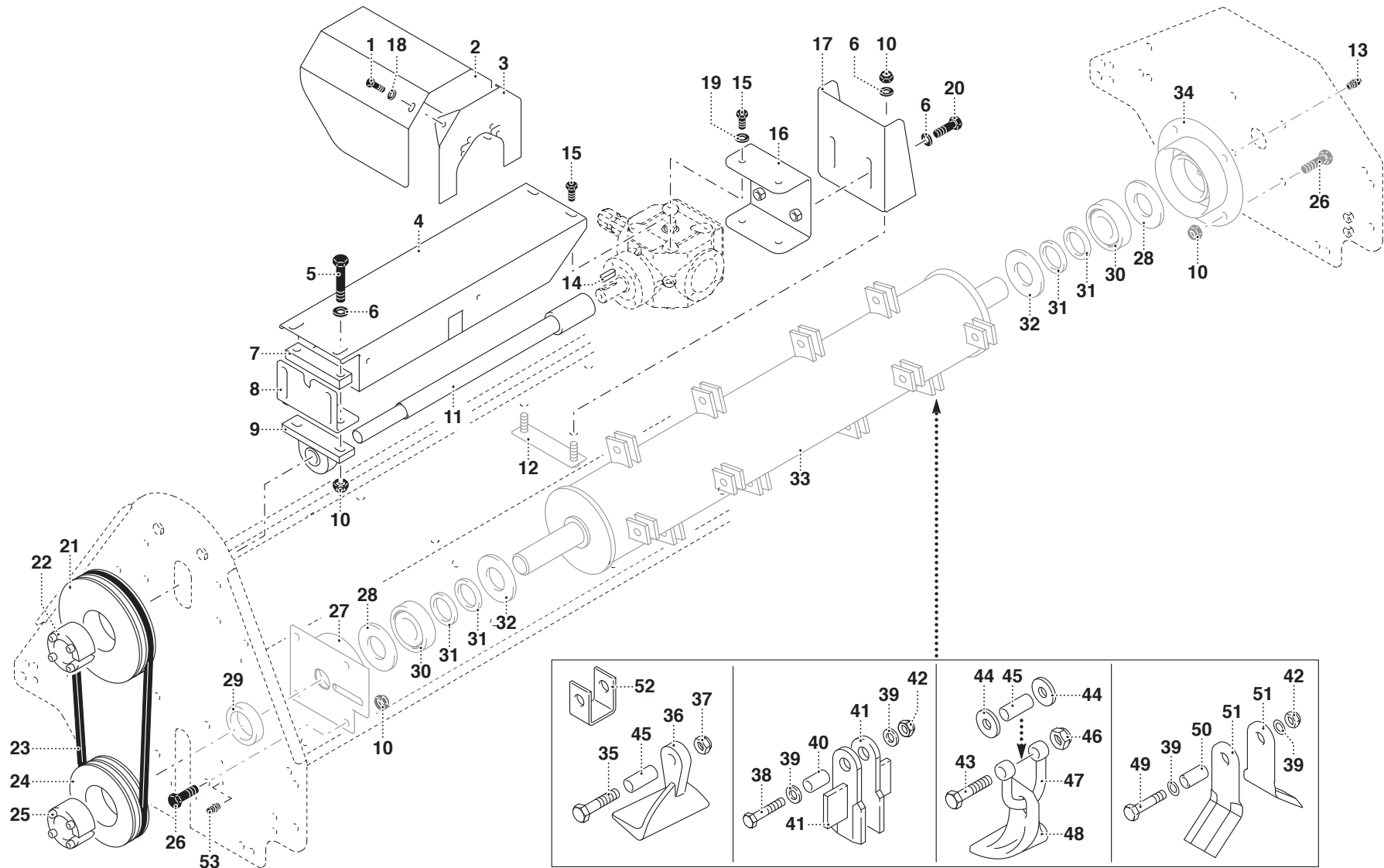

MURATORI MT 29

TAV. 2.0

POS.	N° CODICE	Q.	DESCRIZIONE	DESIGNATION	BENENNUNG	DESCRIPTION	DESIGNAZIONE	Da matr. De nr. serie Vom Seriennr. From serial nr.	Fino matr. Jusqu'au nr. serie Bis Seriennr. Up to serial nr.
1	60015100	2	VITE	VIS	SCHRAUBE	SCREW	TE M8X16 ZNT 5739		
2	39209000	1	PROTEZIONE	PROTECTION	SCHUTZ	GUARD			
3	40304100	1	SUPPORTO	SUPPORT	HALTERUNG	SUPPORT			
4	40265801	1	PROTEZIONE	PROTECTION	SCHUTZ	GUARD	105		
4	40265901	1	PROTEZIONE	PROTECTION	SCHUTZ	GUARD	130		
4	40266001	1	PROTEZIONE	PROTECTION	SCHUTZ	GUARD	155		
4	40288100	1	PROTEZIONE	PROTECTION	SCHUTZ	GUARD	180		
5	60010100	2	VITE	VIS	SCHRAUBE	SCREW	M12X65 ZNT		
6	61.0050.00		RONDELLA	RONDELLE	SCHEIBE	WASHER	D.12 ZNT 6592		
7	30212500	1	SPESSORE	EPAISSEUR	DISTANZRING	SPACER			
8	39253600	1	REGOLAZIONE	REGULATEUR	MECHANISCHER REGLER	GOVERNOR			
9	67012600	1	SUPPORTO	SUPPORT	HALTERUNG	SUPPORT	UCP 205		
10	62010600		DADO	ECROU	MUTTER	NUT	M12 CONELOCK		
11	40228501	1	PROLUNGA	RALLONGE	VERLÄNGERUNGSROHR	EXTENSION	105		
11	40228601	1	PROLUNGA	RALLONGE	VERLÄNGERUNGSROHR	EXTENSION	130		
11	40228701	1	PROLUNGA	RALLONGE	VERLÄNGERUNGSROHR	EXTENSION	155		
11	40288200	1	PROLUNGA	RALLONGE	VERLÄNGERUNGSROHR	EXTENSION	180		
12	40273100	1	CONTROPIASTRA	CONTRE-PLAQUE	GEGENPLATTE	COUNTER PLATE			
13	64001800	1	INGRASSATORE	GRAISSEUR	SCHMIERNIPPEL	GREASE FITTING	M10x1 DIR		
14	65001100	1	CHIAVETTA	CLAVETTE	SCHLÜSSEL	KEY	8x7x30		
15	60017900	4	VITE	VIS	SCHRAUBE	SCREW	TE M10X25 ZNT 5739		
16	40347100	1	SUPPORTO	SUPPORT	HALTERUNG	SUPPORT			
17	39386200	1	SOSTEGNO	SUPPORT	TRÄGER	SUPPORT			
18	61002500	2	RONDELLA	RONDELLE	SCHEIBE	WASHER	D.8 EL		
19	61001500	4	RONDELLA	RONDELLE	SCHEIBE	WASHER	D.10 EL.		
20	60023000	2	VITE	VIS	SCHRAUBE	SCREW	TE M12X30 ZNT 5739		

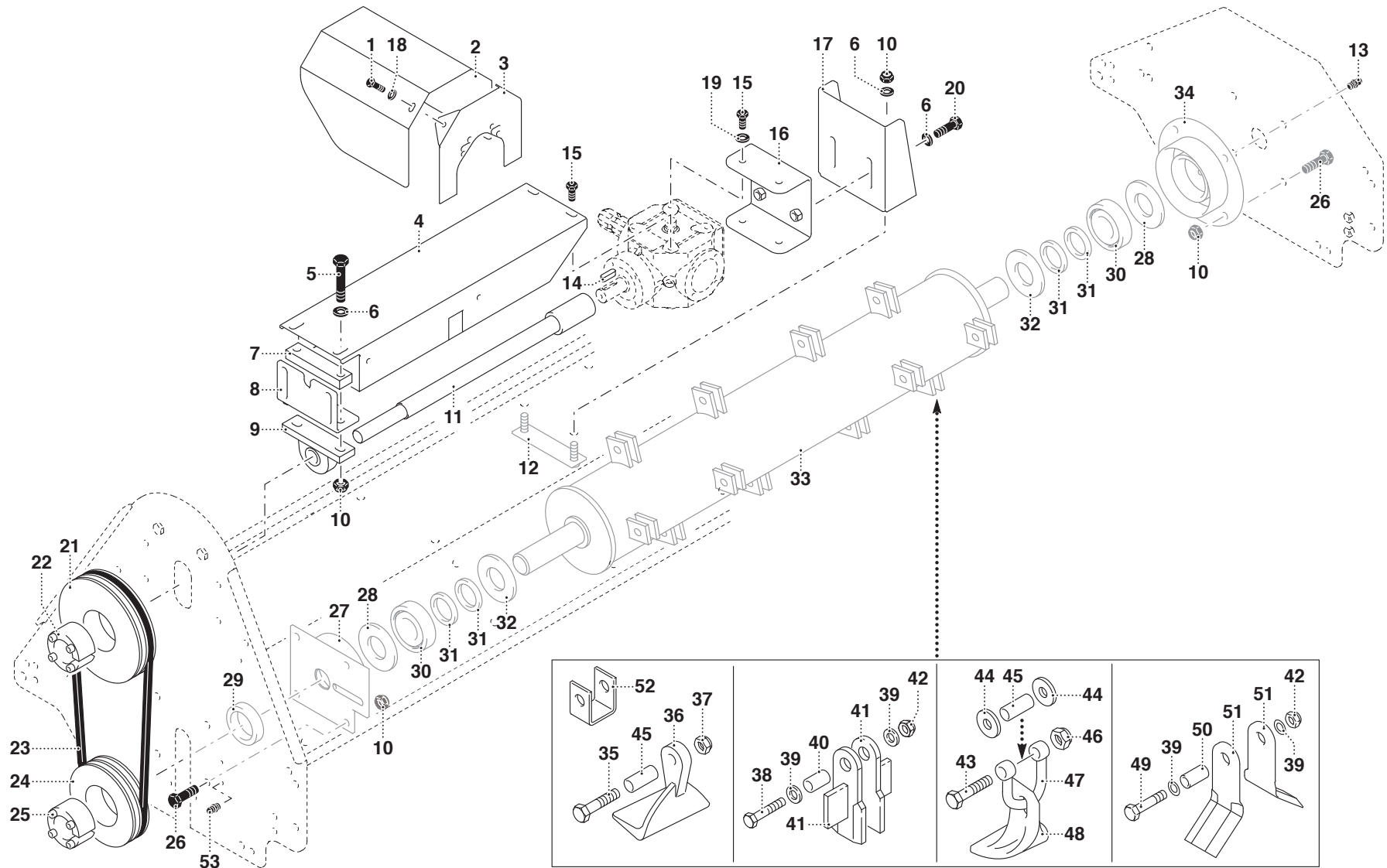

MURATORI MT 29

TAV. 2.0

POS.	N° CODICE	Q.	DESCRIZIONE	DESIGNATION	BENENNUNG	DESCRIPTION	DESIGNAZIONE	Da matr. De nr. serie Vom Seriennr. From serial nr.	Fino matr. Jusqu'au nr. serie Bis Seriennr. Up to serial nr.
21	68121500	1	PULEGGIA	POULIE	RIEMENSCHLEIBE	PULLEY	D.170 2SPA		
22	68058900	1	CALETTATORE	DOUILLE DE SERRAGE	SPANNBUCHSE	LOCKING DEVICE	25x55		
23	68121300	2	CINGHIA	COURROIE	KEILRIEMEN	BELT	A41		
24	68058800	1	PULEGGIA	POULIE	RIEMENSCHLEIBE	PULLEY	D.100 2SPA		
25	68059000	1	CALETTATORE	DOUILLE DE SERRAGE	SPANNBUCHSE	LOCKING DEVICE	30x55		
26	60001400	8	VITE	VIS	SCHRAUBE	SCREW	M12X25		
27	40228000	1	SUPPORTO SX	SUPPORT (G)	HALTER (L)	SUPPORT (LH)			
28	32068000	2	SPESSORE	EPAISSEUR	DISTANZRING	SPACER			
29	66014000	1	ANELLO TENUTA	JOINT D'ETANCHEITE	DICHTUNGSRING	JUNT RING	30X40X4		
30	67012900	2	CUSCINETTO	ROULEMENT	LAGER	BEARING	1306		
31	68068800		SPESSORE	EPAISSEUR	DISTANZRING	SPACER	42X30X1		
32	39091100	2	DISCO	DISQUE	SCHEIBE	DISC			
33	42045400	1	ROTORE	ROTOR	ROTOR	ROTOR	105		
33	42045500	1	ROTORE	ROTOR	ROTOR	ROTOR	130		
33	42045600	1	ROTORE	ROTOR	ROTOR	ROTOR	155		
33	42077800	1	ROTORE	ROTOR	ROTOR	ROTOR	180		
34	40348200	1	SUPPORTO DX	SUPPORT (D)	HALTER (R)	SUPPORT (RH)			
35	60042600		VITE	VIS	SCHRAUBE	SCREW	10 x 50 UNI 5739 ZNT		
36	12019400		MAZZA	MARTEAUX	HAMMER	HAMMER			
37	62010400		DADO	ECROU	MUTTER	NUT	M 10 x 1,5 AUTOBLOCC.		
38	60034400		VITE	VIS	SCHRAUBE	SCREW	TE 8 x 55 UNI 5737		
39	61006200		RONDELLA	RONDELLE	SCHEIBE	WASHER	PIANA Ø 9		
40	31067500		BOCCOLA	DOUILLE	BUECHSE	BUSHING			
41	12016600		COLTELLO VERTICUT	COUTEAU VERTICUT	VERTICUT MESSER	VERTICUT KNIFE			
42	62010200		DADO	ECROU	MUTTER	NUT	M 8 AUTOBLOCC.		
43	60023300	2	VITE	VIS	SCHRAUBE	SCREW	TE 14 x 60 UNI 5737		136326

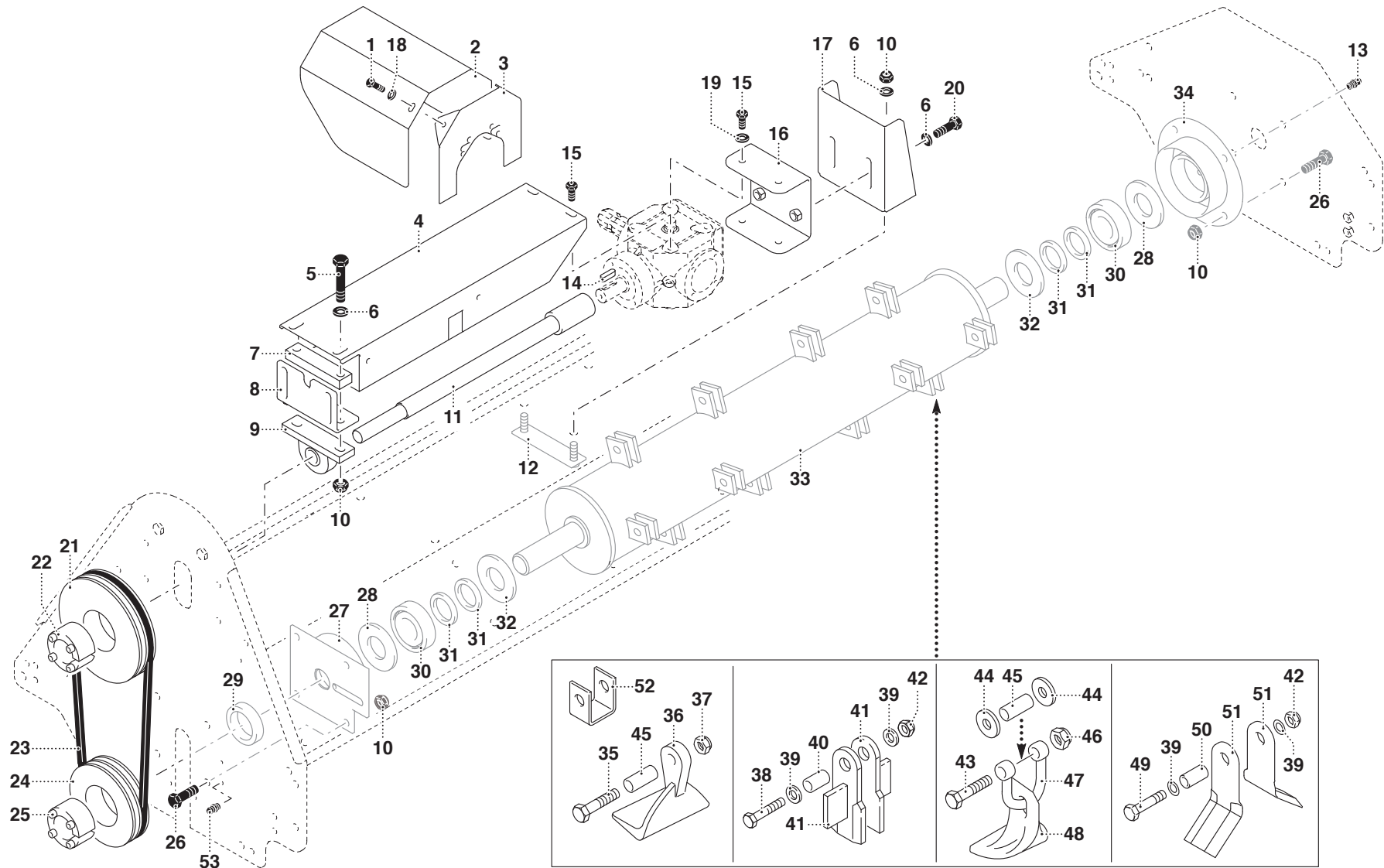

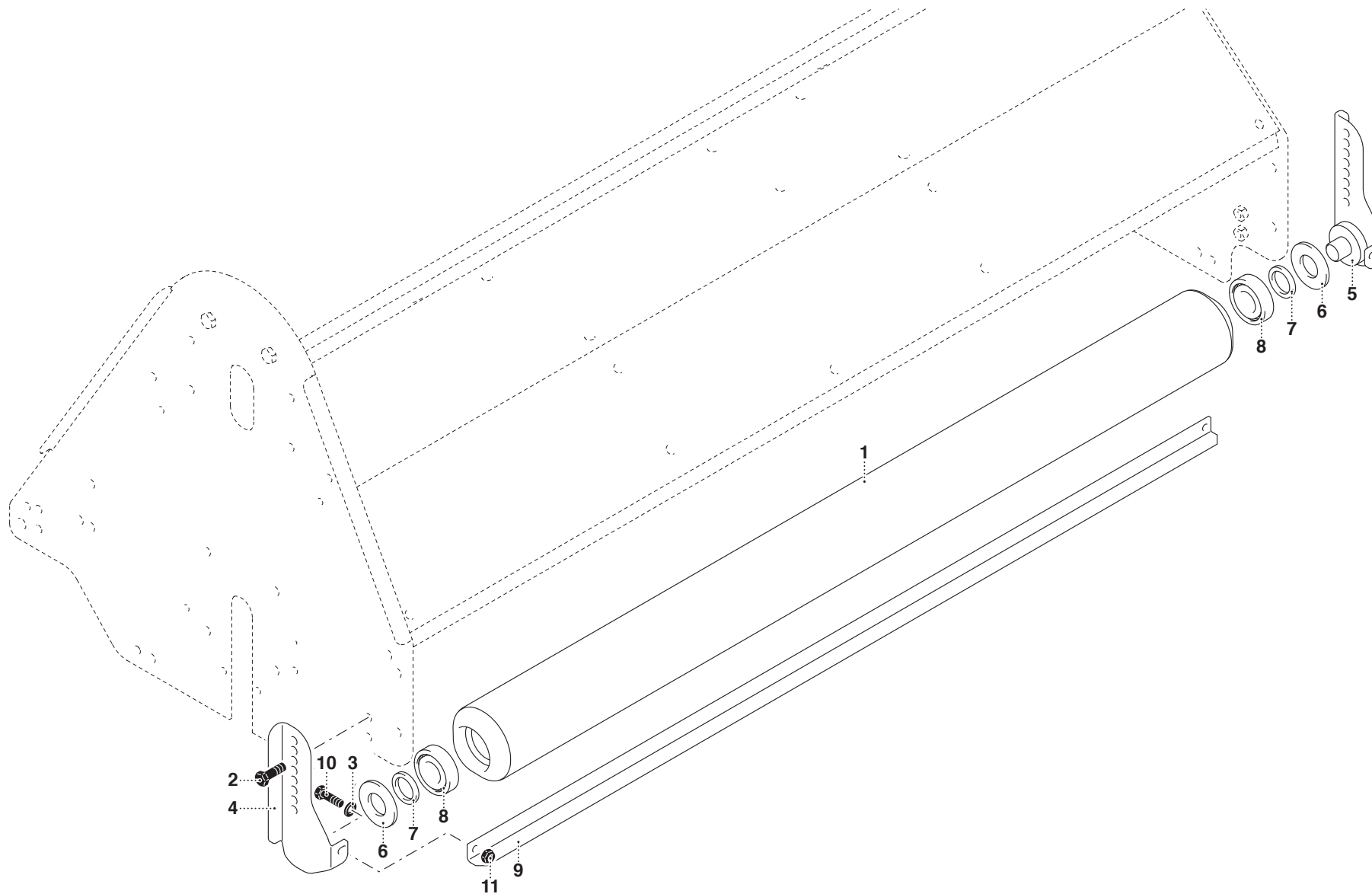

MURATORI MT 29

TAV. 4.0

POS.	N° CODICE	Q.	DESCRIZIONE	DESIGNATION	BENENNUNG	DESCRIPTION	DESIGNAZIONE	Da matr. De nr. serie Vom Seriennr. From serial nr.	Fino matr. Jusqu'au nr. serie Bis Seriennr. Up to serial nr.
1	01020400	1	SCATOLA	CARTER	GEHAEUSE	GEARBOX			
2	39340600	1	COPERCHIO	COUVERCLE	DECKEL	COVER			
3	10050900	1	COPPIA CONICA	COUPLE CONIQUE	KEGELRADTRIEB.	BEVEL GEAR PAIR			
4	46042000	1	MOLTIPLICATORE ORARIO	BOITIER (ROT. STANDARD)		RECHTSDR. GETRIEBE	CLOCKWISE GEAR BOX		
4	46042200	1	MOLTIPLIC. ANTIORARIO	BOITIER (ROT. INVERSE)	LINKSDR. GETRIEBE	COUNTERCL. GEAR BOX			
5	31099200	1	ALBERO	ARBRE	WELLE	SHAFT			
6	67015700	1	CUSCINETTO	ROULEMENT	LAGER	BEARING	30206		
7	67017200	1	CUSCINETTO	ROULEMENT	LAGER	BEARING	30207		
8	67018500	1	CUSCINETTO	ROULEMENT	LAGER	BEARING	6007		
9	67018600	1	CUSCINETTO	ROULEMENT	LAGER	BEARING	6206		
10	66019700	1	ANELLO TENUTA	JOINT D'ETANCHEITE	DICHTUNGSRING	JUNT RING	30 x 62 x 8		
11	66011600	1	ANELLO TENUTA	JOINT D'ETANCHEITE	DICHTUNGSRING	JUNT RING	35 x 62 x 7		
12	68123900	1	CAPPELLOTTO	BOUCHON	ABSCHLUSSKAPPE	CAP NUT	62 x 9,5		
13	60015100	4	VITE	VIS	SCHRAUBE	SCREW	TE 8 x 16 UNI 5739		
14	63005700	1	ANELLO ELASTICO	ARRETOIR	SPANNRING	SNAP-RING	Ø30 E UNI 7436		
15	63005000	1	ANELLO ELASTICO	ARRETOIR	SPANNRING	SNAP-RING	Ø42 E UNI 7435		
16	63005200	1	ANELLO ELASTICO	ARRETOIR	SPANNRING	SNAP-RING	Ø62 I UNI 7437		
17	68124500	3	TAPPO	BOUCHON	STOPFEN	PLUG			
18	68124100	1	SPESSORE	EPAISSEUR	DISTANZRING	SPACER	30 x 40 x 0,5		
19	68124200	1	SPESSORE	EPAISSEUR	DISTANZRING	SPACER	30 x 40 x 1		
20	68039000	1	SPESSORE	EPAISSEUR	DISTANZRING	SPACER	62 x 50 x 0,3		
21	68124300	1	SPESSORE	EPAISSEUR	DISTANZRING	SPACER	62 x 50 x 0,5		
22	68011500	2	SPESSORE	EPAISSEUR	DISTANZRING	SPACER	62 x 50 x 1		
23	68124400	4	MOLLA	RESSORT	FEDER	SPRING			
24	65003500	2	CHIAVETTA	CLAVETTE	KEIL	SPLINE			
25	68085600	1	TAPPO	BOUCHON	STOPFEN	PLUG			

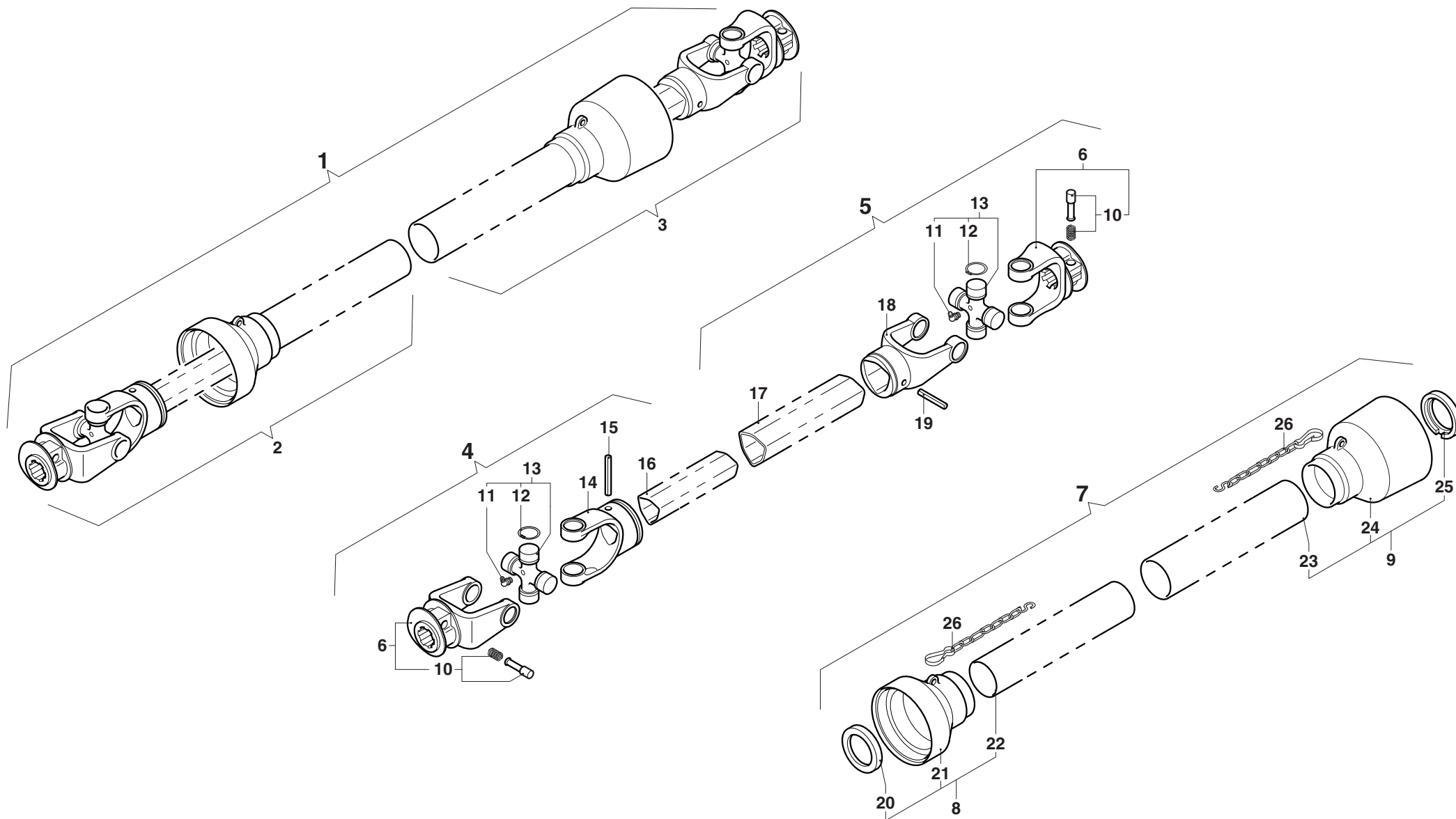

MURATORI MT 29

TAV. 6.0

POS.	N° CODICE	Q.	DESCRIZIONE	DESIGNATION	BENENNUNG	DESCRIPTION	DESIGNAZIONE	Da matr. De nr. serie Vom Seriennr. From serial nr.	Fino matr. Jusqu'au nr. serie Bis Seriennr. Up to serial nr.
1	AB207SF	1	ALBERO CARDANICO COMPLETO	ARBRE A JOINTS DE CARDAN	KARDANWELLE	PTO SHAFT			
2	B2070B1	1	SEMIALBERO INTERNO	DEMI-ARBRE INTERIEUR	INNENHALBWELLE	INTERNAL HALF SHAFT			
3	B2070B2	1	SEMIALBERO ESTERNO	DEMI-ARBRE EXTERIEUR	AUSSENHALBWELLE	EXTERNAL HALF SHAFT			
4	B207001	1	SEMIALBERO INTERNO	DEMI-ARBRE INTERIEUR	INNENHALBWELLE	INTERNAL HALF SHAFT			
5	B2070002	1	SEMIALBERO ESTERNO	DEMI-ARBRE EXTERIEUR	AUSSENHALBWELLE	EXTERNAL HALF SHAFT			
6	0800203	2	FORCELLA	FOURCHE	GABEL	YOKE			
7	083B02070	1	PROTEZIONE	PROTECTION	SCHUTZ	GUARD			
8	083B020701	1	PROTEZIONE INTERNA	PROTECTION INTERIEURE	INNENSCHUTZ	INTERNAL GUARD			
9	083B020702	1	PROTEZIONE ESTERNA	PROTECTION EXTERIEURE	AUSSENSCHUTZ	EXTERNAL GUARD			
10	0986014047	2	PULSANTE	BOUTON	DRUCKKNOPF	PUSH BOTTON			
11	09840081002	2	INGRASSATORE	GRAISSEUR	SCHMIERNIPPEL	GREASE FITTING			
12	098020224	8	ANELLO ELASTICO	ARRETOIR	SPANNRING	SNAP-RING			
13	08202	2	CROCIERA	CROISILLON	KREUZSTÜCK	SPIDER			
14	08002011	1	FORCELLA	FOURCHE	GABEL	YOKE			
15	098700850	1	SPINA ELASTICA	GOUPILLE ELASTIQUE	SPANNSTIFT	ELASTIC PIN			
16	09881294100	1	TUBO INTERNO	TUBE INTERIEUR	INNENROHR	INTERNAL TUBE			
17	09881363100	1	TUBO ESTERNO	TUBE EXTERIEUR	AUSSENROHR	EXTERNAL TUBE			
18	08002021	1	FORCELLA	FOURCHE	GABEL	YOKE			
19	098700855	1	SPINA ELASTICA	GOUPILLE ELASTIQUE	SPANNSTIFT	ELASTIC PIN			
20	0265220008	1	GHIERA	FRETTE	NUTMUTTER	RING NUT			
21	0256010425	1	CUFFIA	CAPOUCHON	HAUBE	GUARD			
22	0988955B2070	1	TUBO INTERNO	TUBE INTERIEUR	INNENROHR	INTERNAL TUBE			
23	0988961B2070	1	TUBO ESTERNO	TUBE EXTERIEUR	AUSSENROHR	EXTERNAL TUBE			
24	0256010424	1	CUFFIA	CAPOUCHON	HAUBE	GUARD			
25	0265220007	1	GHIERA	FRETTE	NUTMUTTER	RING NUT			

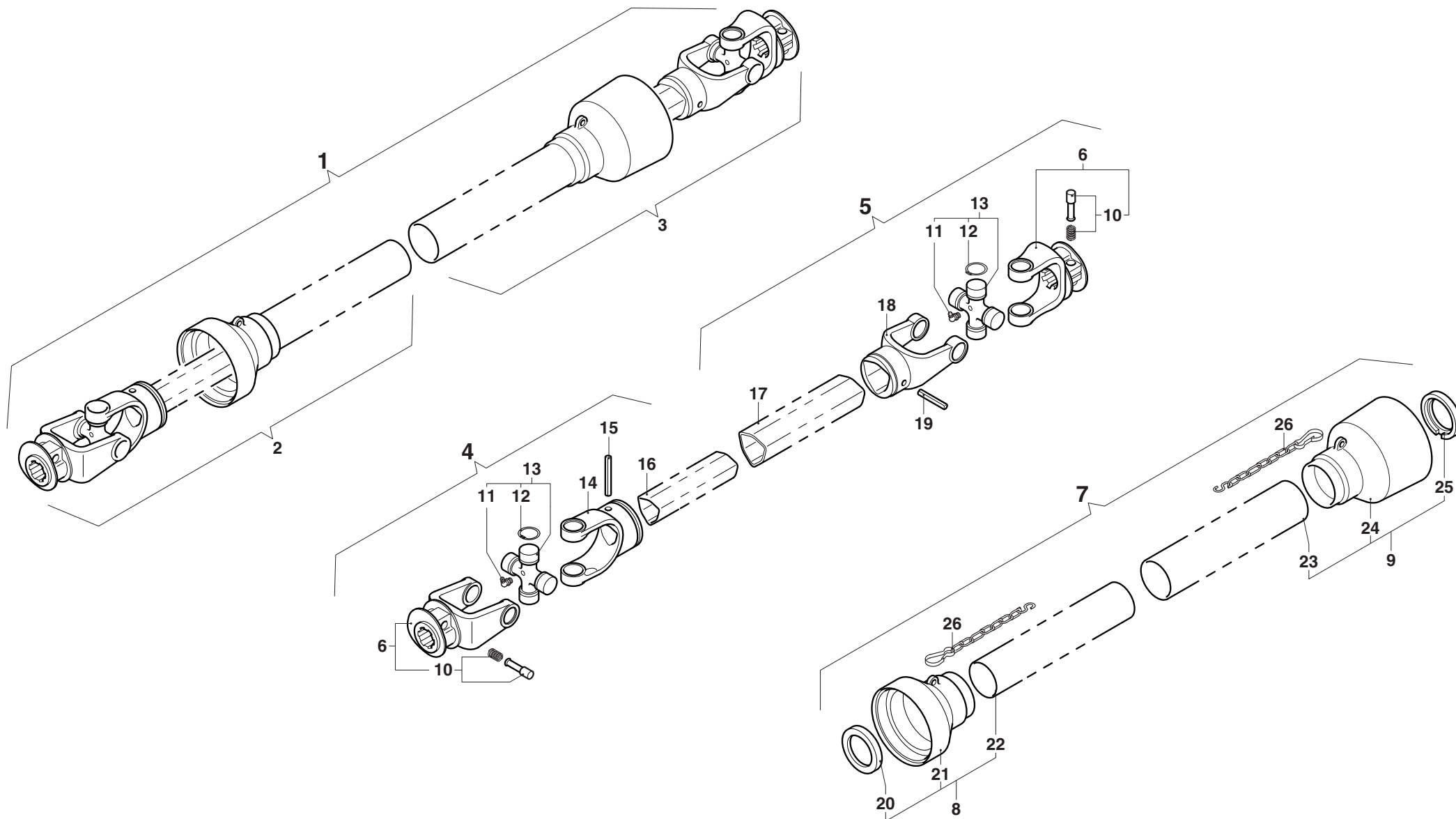



MURATORI S.p.A.

Via Pavarello, 21 - 41051 Castelnuovo Rangone (MO) Italy - Tel. 059.5330611 Fax 059.537259

www.muratoriequip.it *info@muratoriequip.it*

Capitale sociale Euro 480.000 interamente versato

Registro Imprese di Modena

Codice fiscale e numero d'iscrizione: 00708860366