



MURATORI

**TIPO-TYPE-TYP
MZ2S**

CATALOGO RICAMBI
Catalogue Pièces Detachées
Ersatzteilkatalog
Spare Parts Catalogue
Catálogo Recambios

EDIZIONE 09/2019



**NORME PER LE ORDINAZIONI - COMMANDES/NORMES - BESTELLNORMEN - HOW TO ORDER
INDICE DELLE TAVOLE - INDEX DES TABLES - TAFELVERZEICHNIS - TABLES INDEX**

MZ2S

Per ordinare parti di ricambio specificare:

- tipo e matricola della macchina (apposti sulla macchina o sui documenti di acquisto);
- numero del riferimento del pezzo nel disegno (Pos.), numero della tavola (Tav.) e numero di codice

N.B.: le indicazioni destro o sinistro vengono date guardando la macchina da dietro.

Pour les commandes de pièces de rechange veuillez spécifier:

- type et numéro de série de la machine (indiqués sur la machine et sur le bon d'achat);
- numéro de référence du pièce sur le plan (Pos.), numéro du plan (Tav.) et numéro de code (codice)

N.B.: les indications droite ou gauche sont données en regardant la machine par derrière.

Zum Bestellen von Ersatzteilen folgendes angeben:

- Typ und Serien-Nr. der Maschine (zu finden auf der Maschine oder der Einkaufspapieren);
- Bezug-Nr. des Ersatzteils auf der Zeichnung (Pos.), Zeichnungsnummer (Tav.) und Kodenummer (codice)

N.B.: Die Angaben rechts und links verstehen sich so, dass man hinter der Maschine steht.

When ordering spare parts specify:

- machine type and serial number (found on the machine or on the purchasing documents);
- reference number of the part on the relative drawing (Pos.), number of the drawing (Tav.) and part number (codice)

N.B.: right-hand or left-hand indications are made by viewing the machine from the rear.

TAV. 1.0
GRUPPO TELAIO
ENSEMBLE CHASSIS
SATZ FÜR RAHMEN
KIT FOR FRAME

TAV. 2.0
GRUPPO RULLO ROTORE STANDARD A 4 ZAPPE
ENSEMBLE ROTOR STANDARD A 4 LAMES
SATZ FÜR STANDARDROTOR ZU 4 MESSER
KIT FOR STANDARD ROTOR 4 BLADES

TAV. 3.0
GRUPPO RIDUTTORE A 1 VELOCITA' (TIPO "COMER")
ENSEMBLE BOITIER MONOVITNESS (TYPE "COMER")
SATZ FÜR EINGANGGETRIEBE ("COMER" TYP)
KIT FOR ONE-SPEED GEAR BOX ("COMER" TYPE)

TAV. 3.1
GRUPPO RIDUTTORE A 1 VELOCITA' (TIPO "FERRONI")
ENSEMBLE BOITIER MONOVITNESS (TYPE "FERRONI")
SATZ FÜR EINGANGGETRIEBE ("FERRONI" TYP)
KIT FOR ONE-SPEED GEAR BOX ("FERRONI" TYPE)

TAV. 4.0
PROTEZIONI ANTINFORTUNISTICHE "CE" E PIEDINO DI AP-
POGGIO
PROTECTIONS "CE" ET PIEDISTAL
UNFALLSCHUTZVORRICHTUNGEN "CE" UND STUTZHALTER
SAFETY GUARDS "CE" AND STANDING JACK

TAV. 5.0
ALBERO CARDANICO COMPLETO
ARBRE A JOINTS DE CARDAN
KARDANWELLE
PTO SHAFT

TAV. 6.0
ALBERO CARDANICO COMPLETO
ARBRE A JOINTS DE CARDAN
KARDANWELLE
PTO SHAFT

TAV. 6.1
ALBERO CARDANICO COMPLETO
ARBRE A JOINTS DE CARDAN
KARDANWELLE
PTO SHAFT

TAV. 7.0
ALBERO CARDANICO COMPLETO
ARBRE A JOINTS DE CARDAN
KARDANWELLE
PTO SHAFT

TAV. 8.0
ALBERO CARDANICO COMPLETO
ARBRE A JOINTS DE CARDAN
KARDANWELLE
PTO SHAFT

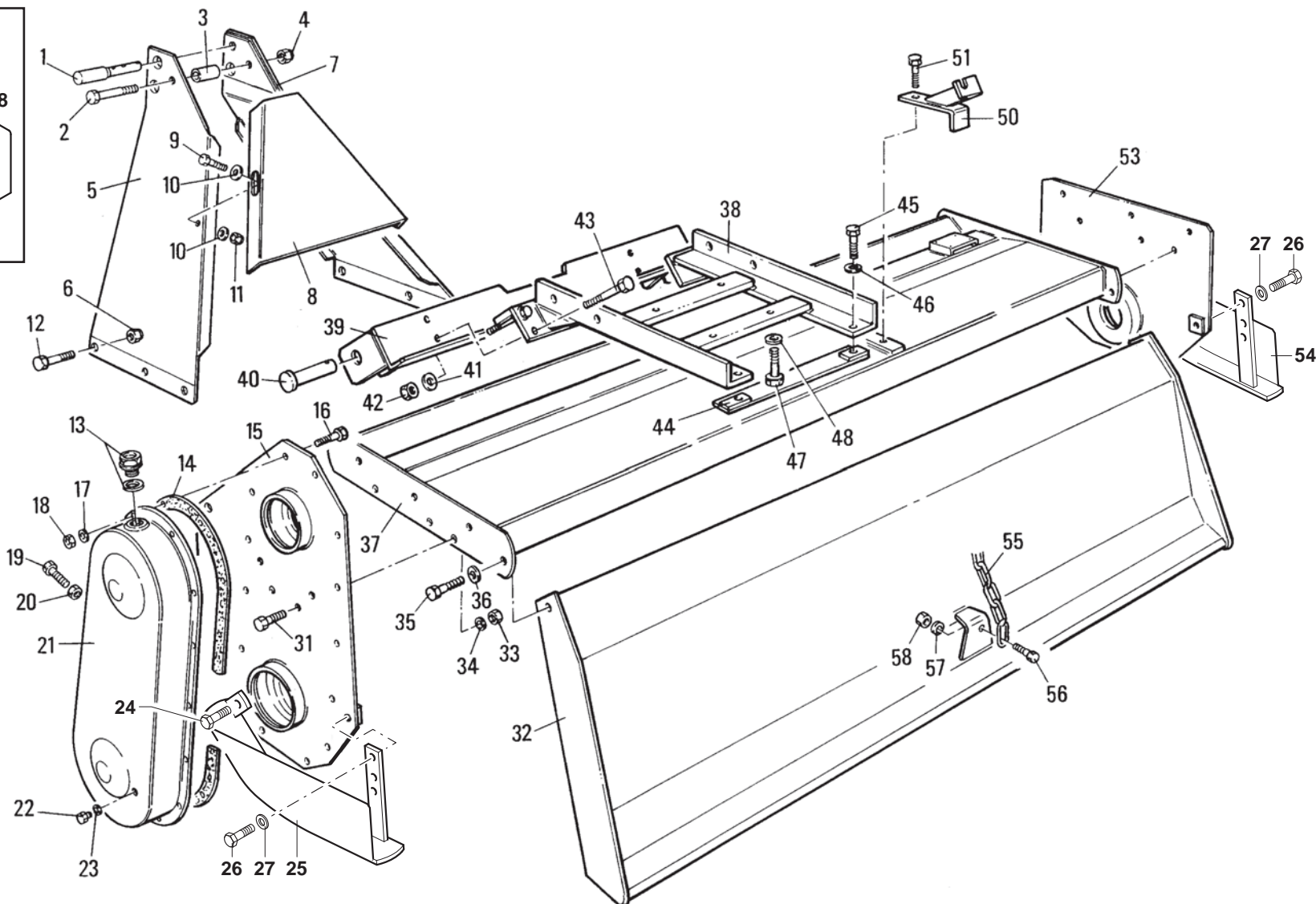
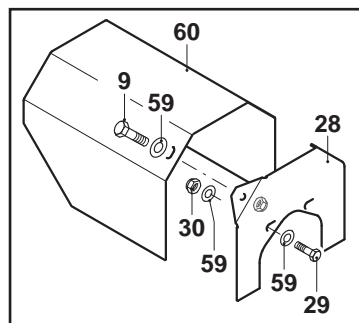

MURATORI MZ2S

TAV. 1.0

POS.	N° CODICE	Q	DESCRIZIONE	DESIGNATION	BENENNUNG	DESCRIPTION	DESIGNAZIONE	Da matr. De nr. serie Vom Seriennr. From serial nr.	Fino matr Jusqu'au nr. serie Bis Seriennr. Up to serial nr.
1	68062000	1	PERNO	AXE	BOLZEN	PIN			
2	60030200	1	VITE	VIS	SCHRAUBE	SCREW	TE 10x80 UNI 5737		
3	32069101	1	DISTANZIALE	ENTRETOISE	DISTANZSTÜCK	SPACER			
4	62010400	1	DADO	ECROU	MUTTER	NUT	M 10x1,5 AUTOBLOCC.		
5	40091900	1	ARCATA SX	ARCADE (G)	ARKADE (LINKS)	ARCADE (LH)			
6	62010400	4	DADO	ECROU	MUTTER	NUT	M 10x1,5 AUTOBLOCC.		
7	40092000	1	ARCATA DX	ARCADE (D)	ARKADE (RECHTS)	ARCADE (RH)			
8	39098000	1	CHIUSURA	FERMATURE	VERSCHLUSS	LOCK			
9	60015100	4	VITE	VIS	SCHRAUBE	SCREW	TE 8x16 UNI 5739 ZNT		
10	61004700	4	RONDELLA	RONDELLE	SCHEIBE	WASHER	PIANA Ø 8 UNI 6592 ZNT		
11	62007200	2	DADO	ECROU	MUTTER	NUT	M 8x1,25 UNI 5587 ZNT		
12	60017900	4	VITE	VIS	SCHRAUBE	SCREW	TE 10x25 UNI 5739 ZNT		
13	68000500	1	TAPPO	BOUCHON	STOPFEN	PLUG			
14	80006600	1	GUARNIZIONE	GARNITURE	DICHTUNG	SEAL			
15	40034601	1	PIASTRA	PLAQUE	PLATTE	PLATE			
16	60022800	10	VITE	VIS	SCHRAUBE	SCREW	TE 8x20 UNI 5739 8.8 ZNT		
17	61000600	10	RONDELLA	RONDELLE	SCHEIBE	WASHER	DENT. INT. Ø 8 UNI 3704		
18	62000700	10	DADO	ECROU	MUTTER	NUT	M 8x1,25 UNI 5587		
19	60030200	1	VITE	VIS	SCHRAUBE	SCREW	TE 10x80 UNI 5739		
20	62000500	1	DADO	ECROU	MUTTER	NUT	M 10x1,5 UNI 5587		
21	40033000	1	COPERCHIO	COUVERCLE	DECKEL	COVER			
22	60001100	1	VITE	VIS	SCHRAUBE	SCREW	TE 10x10 UNI 5739 4.8		
23	61000800	1	RONDELLA	RONDELLE	SCHEIBE	WASHER	PIANA Ø10 ALLUMINIO		
24	60017900	2	VITE	VIS	SCHRAUBE	SCREW	TE 10x25 UNI 5739 8.8 ZNT		
25	40311200	1	SLITTA SX	PATIN (G)	KUFE (L)	SKID (LH)			
26	60021600	2	VITE	VIS	SCHRAUBE	SCREW	TE 10x20 UNI 5739 8.8 ZNT		

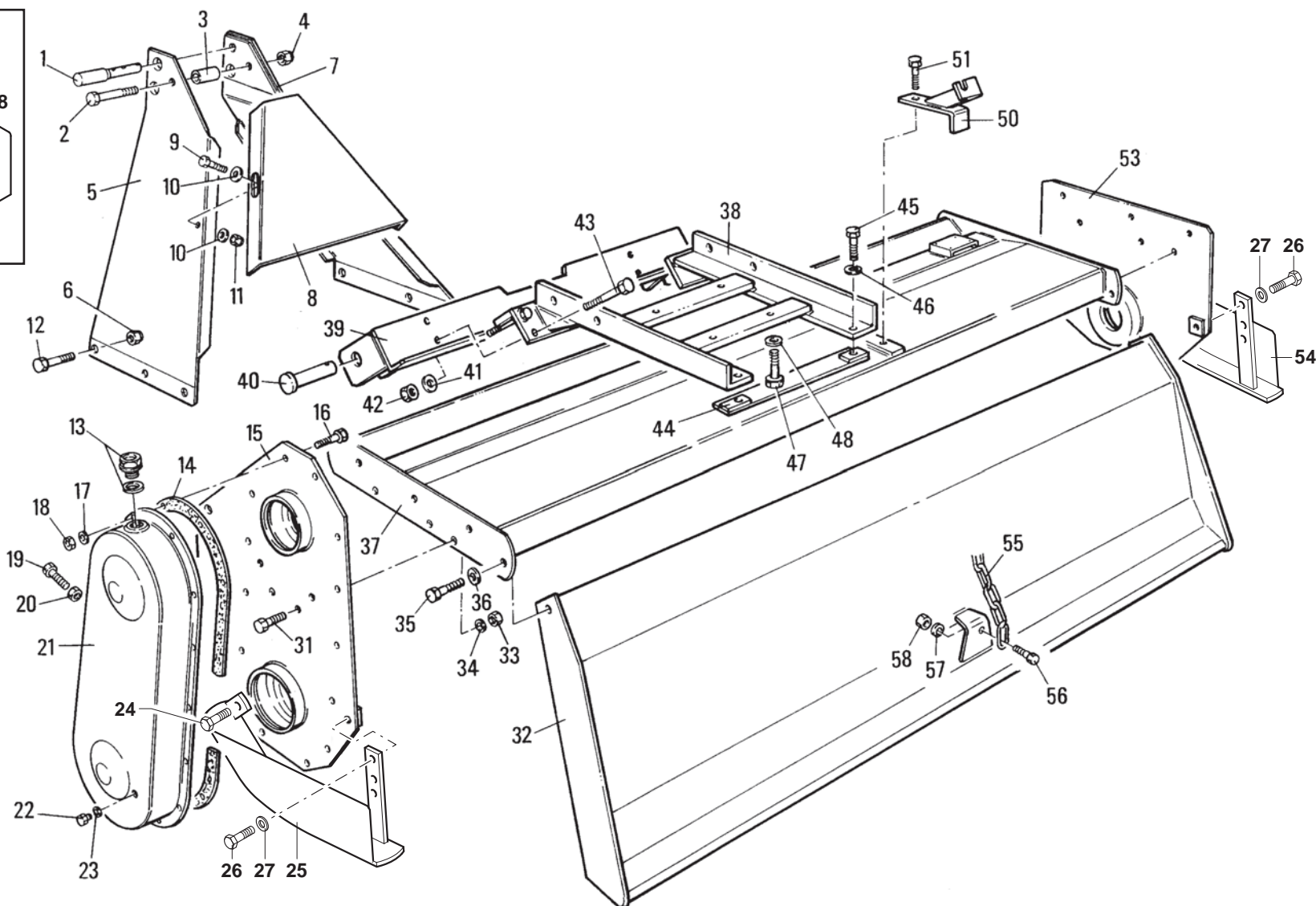
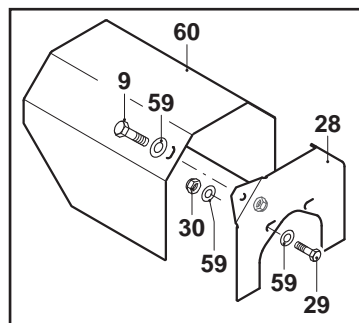

MURATORI MZ2S

TAV. 1.0

POS.	N° CODICE	Q	DESCRIZIONE	DESIGNATION	BENENNUNG	DESCRIPTION	DESIGNAZIONE	Da matr.	Fino matr
								De nr. serie Vom Seriennr. From serial nr.	Jusqu'au nr. serie Bis Seriennr. Up to serial nr.
27	61000400	2	RONDELLA	RONDELLE	SCHEIBE	WASHER	DENT. INT. Ø10 UNI 3704		
28	40304100	1	SUPPORTO	SUPPORT	HALTERUNG	SUPPORT			
29	60022800	2	VITE	VIS	SCHRAUBE	SCREW	TE 8x20 UNI 5739		
30	62010200	4	DADO	ECROU	MUTTER	NUT	M 8x1,25 AUTOBLOCC.		
31	60017900	12	VITE	VIS	SCHRAUBE	SCREW	TE 10x25 UNI 5739 8.8 ZNT		
32	41060900	1	COFANO	CAPOT	SCHUTZHAUBE	HOOD	MZ2S 085		
32	41061100	1	COFANO	CAPOT	SCHUTZHAUBE	HOOD	MZ2S 105		
32	41061200	1	COFANO	CAPOT	SCHUTZHAUBE	HOOD	MZ2S 115		
32	41061300	1	COFANO	CAPOT	SCHUTZHAUBE	HOOD	MZ2S 125		
33	62000500	12	DADO	ECROU	MUTTER	NUT	M 10x1,5 UNI 5587		
34	61000400	12	RONDELLA	RONDELLE	SCHEIBE	WASHER	DENT. INT. Ø10 UNI 3704		
35	60010700	2	VITE	VIS	SCHRAUBE	SCREW	TE 10x45 UNI 5739		
36	61001500	2	RONDELLA	RONDELLE	SCHEIBE	WASHER	GROWER Ø10 UNI 1751		
37	41083000	1	TELAIO	CHASSIS	RAHMEN	FRAME	MZ2S 085		
37	41083200	1	TELAIO	CHASSIS	RAHMEN	FRAME	MZ2S 105		
37	41083300	1	TELAIO	CHASSIS	RAHMEN	FRAME	MZ2S 115		
37	41083400	1	TELAIO	CHASSIS	RAHMEN	FRAME	MZ2S 125		
38	40110200	1	CASTELLO SCORR.	SYSTEME DEPORTABLE	GLEITENSCHLOSS	SLIDING SYSTEM			
39	40138800	1	RISCONTRO ANT.	BUTEE ANT.	VORDERE GEGENPLATTE	FRONT STRIKER			
39	40182700	1	RISCONTRO ANT.	BUTEE ANT.	VORDERE GEGENPLATTE	FRONT STRIKER	CAT. 0		
40	68062300	2	PERNO	AXE	BOLZEN	PIN			
40	68075300	2	PERNO	AXE	BOLZEN	PIN	CAT. 0		
41	61000400	4	RONDELLA	RONDELLE	SCHEIBE	WASHER	DENT. int Ø10 UNI 3704		
42	62000500	4	DADO	ECROU	MUTTER	NUT	M 10 x 1,5 UNI 5587		
43	60006800	2	VITE	VIS	SCHRAUBE	SCREW	TE 10x70 UNI 5737		
44	40069600	1	PIATTO	PLAQUE	PLATTE	DISC			

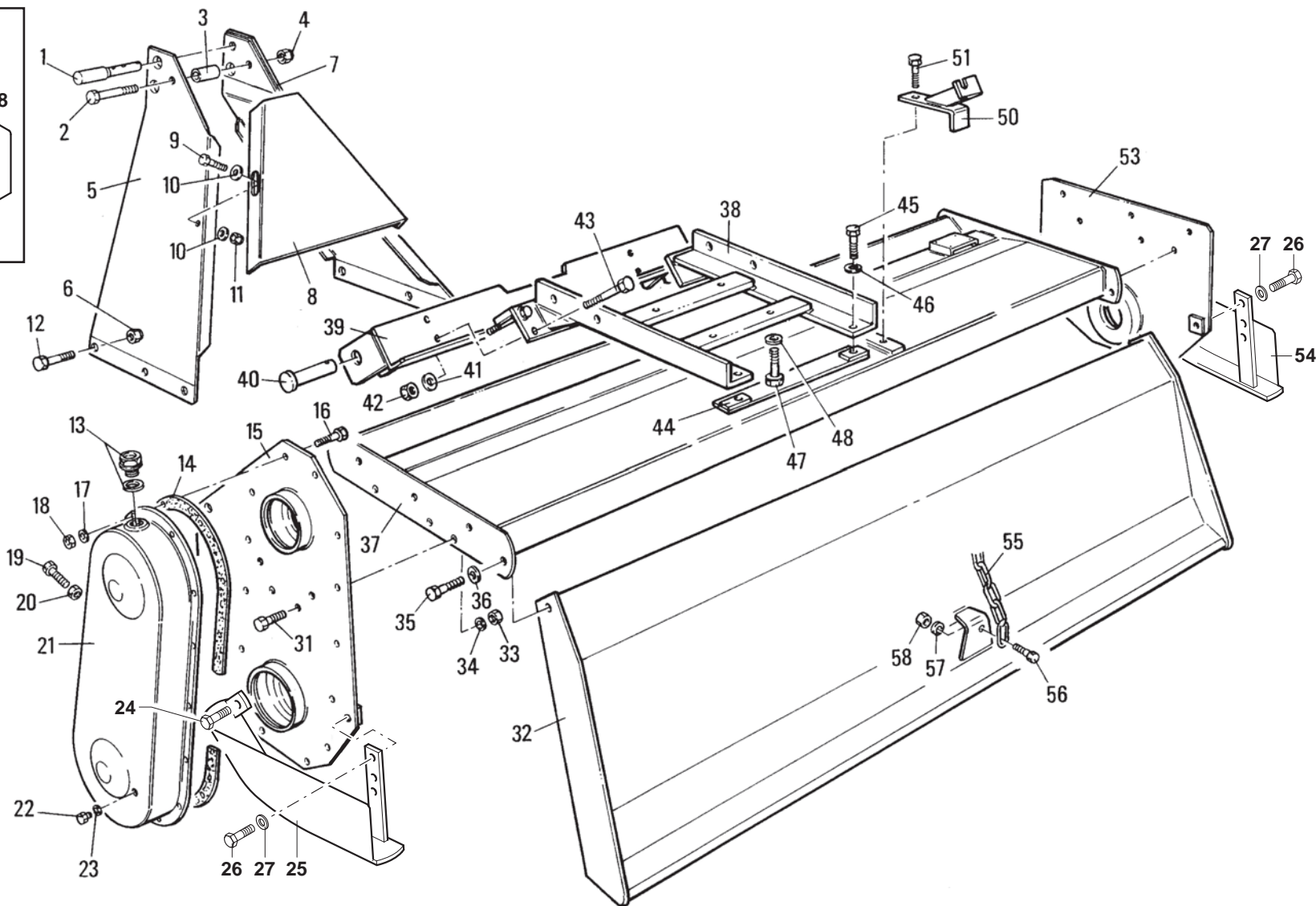
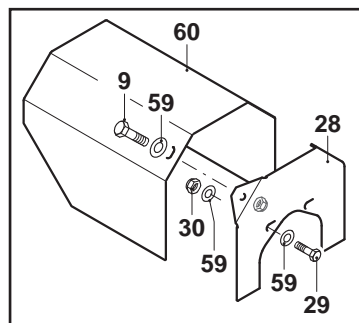

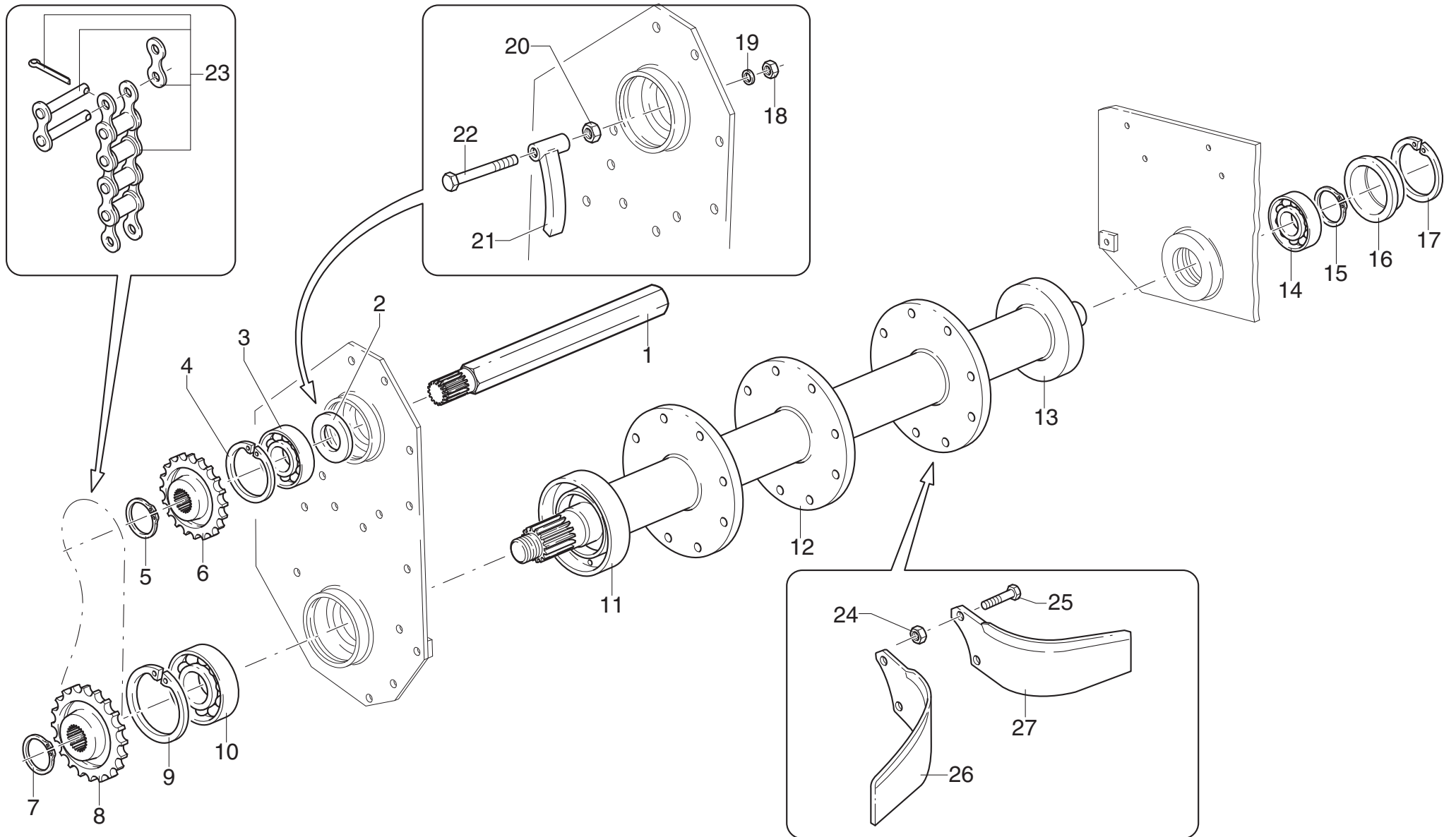

MURATORI MZ2S

TAV. 2.0

POS.	N° CODICE	Q	DESCRIZIONE	DESIGNATION	BENENNUNG	DESCRIPTION	DESIGNAZIONE	Da matr.	Fino matr
								De nr. serie Vom Seriennr. From serial nr.	Jusqu'au nr. serie Bis Seriennr. Up to serial nr.
1	38010800	1	SEMIASSE	DEMI-ESSIEU	ACHSWELLE	AXLE SHAFT	085		
1	38011000	1	SEMIASSE	DEMI-ESSIEU	ACHSWELLE	AXLE SHAFT	105		
1	38011200	1	SEMIASSE	DEMI-ESSIEU	ACHSWELLE	AXLE SHAFT	125		
2	68011500	1	SPESSORE	EPAISSEUR	DISTANZRING	SPACER			
3	67008500	1	CUSCINETTO	ROULEMENT	LAGER	BEARING	6206 2RS		
4	63005200	1	ANELLO ELASTICO	ARRETOIR	SPANNRING	SNAP-RING	Ø 62 I UNI 7437		
5	63000400	1	ANELLO ELASTICO	ARRETOIR	SPANNRING	SNAP-RING	Ø 30 E UNI 7435		
6	10014900	1	PIGNONE	PIGNON	RITZEL	PINION	Z 11 - 3/4"		
7	63002400	1	ANELLO ELASTICO	ARRETOIR	SPANNRING	SNAP-RING	Ø 34 E UNI 7435		
8	10014801	1	CORONA	COURONNE	KRANZ	CROWN	Z 19 - 3/4"		
9	63000300	1	ANELLO ELASTICO	ARRETOIR	SPANNRING	SNAP-RING	Ø 72 I UNI 7437		
10	67006700	1	CUSCINETTO	ROULEMENT	LAGER	BEARING	6207 2RS		
11	39083600	1	CAPPELOTTO SX	BOUCHON (G)	ABSCHLUSSKAPPE (L)	CAP NUT (LH)			
12	42009502	1	ROTORE	ROTOR	ROTOR	ROTOR	085		
12	42009702	1	ROTORE	ROTOR	ROTOR	ROTOR	105		
12	42009902	1	ROTORE	ROTOR	ROTOR	ROTOR	125		
13	39083500	1	CAPPELOTTO DX	BOUCHON (D)	ABSCHLUSSKAPPE (R)	CAP NUT (RH)			
14	67006400	1	CUSCINETTO	ROULEMENT	LAGER	BEARING	6206 2RS		
15	63000400	1	ANELLO ELASTICO	ARRETOIR	SPANNRING	SNAP-RING	Ø 30 E UNI 7435		
16	39036500	1	COPERCHIO	COUVERCLE	DECKEL	COVER			
17	63005200	1	ANELLO ELASTICO	ARRETOIR	SPANNRING	SNAP-RING	Ø 62 I UNI 7437		
18	62001100	1	DADO	ECROU	MUTTER	NUT	M 12x1,75 UNI 5589		
19	61000500	1	RONDELLA	RONDELLE	SCHEIBE	WASHER	DENT. INT. Ø 12 UNI 3704		
20	62001100	1	DADO	ECROU	MUTTER	NUT	M 12x1,75 UNI 5589		
21	45194600	1	TENDICATENA	TENDEUR DE CHAINE	KETTENHALTERUNG	CHAINE TIGHTENER			
22	60046800	1	VITE	VIS	SCHRAUBE	SCREW	TCEI 12x50 UNI 5931		

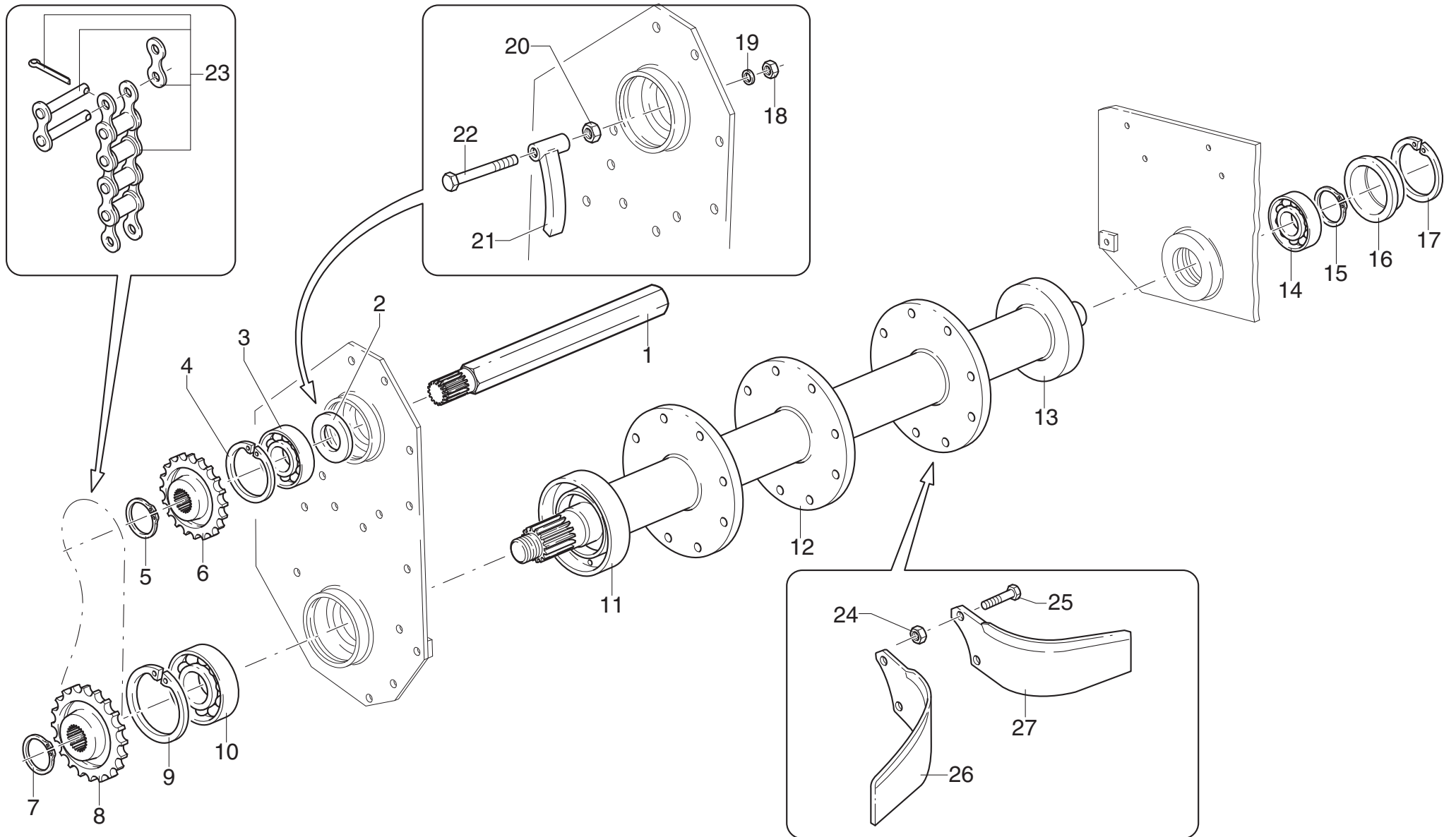

TIPO "COMER" - TYPE "COMER" - "COMER" TYP - "COMER" TYPE

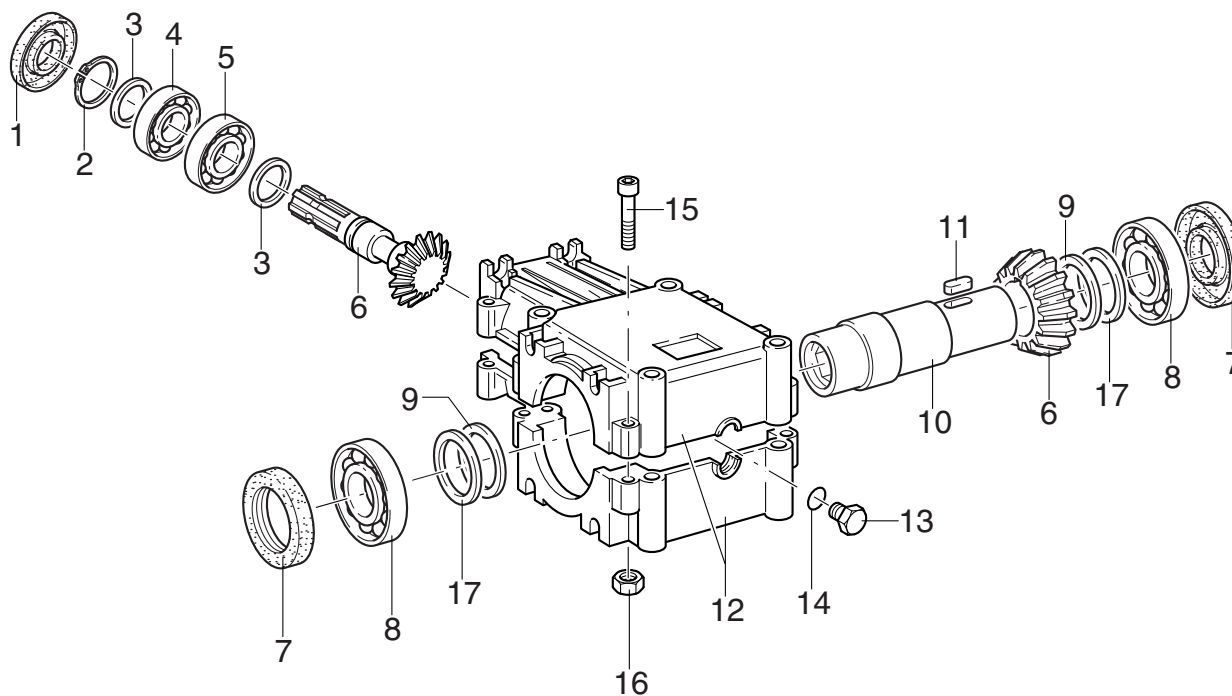
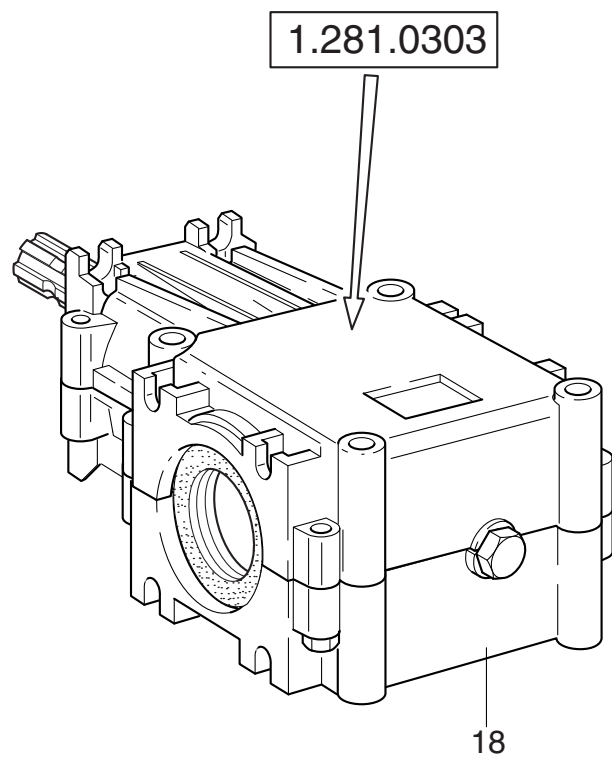

TIPO "FERRONI" - TYPE "FERRONI" - "FERRONI" TYP - "FERRONI" TYPE

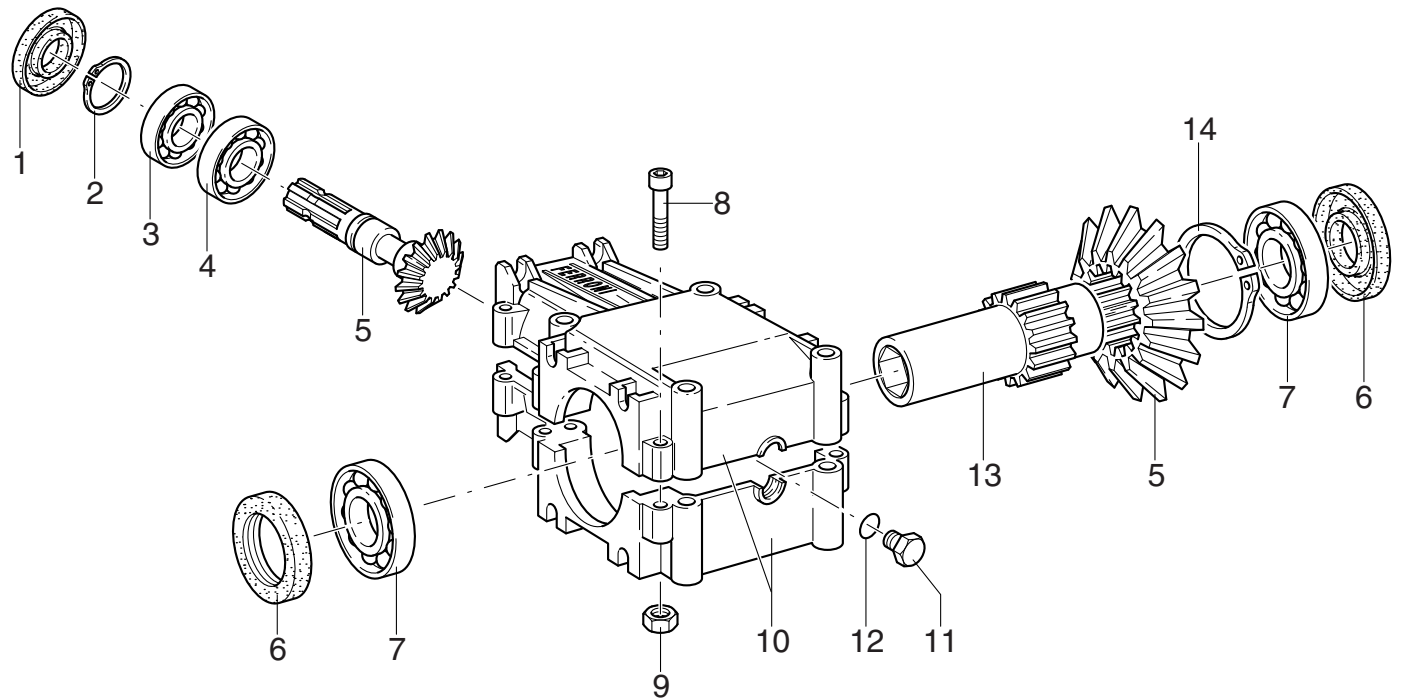
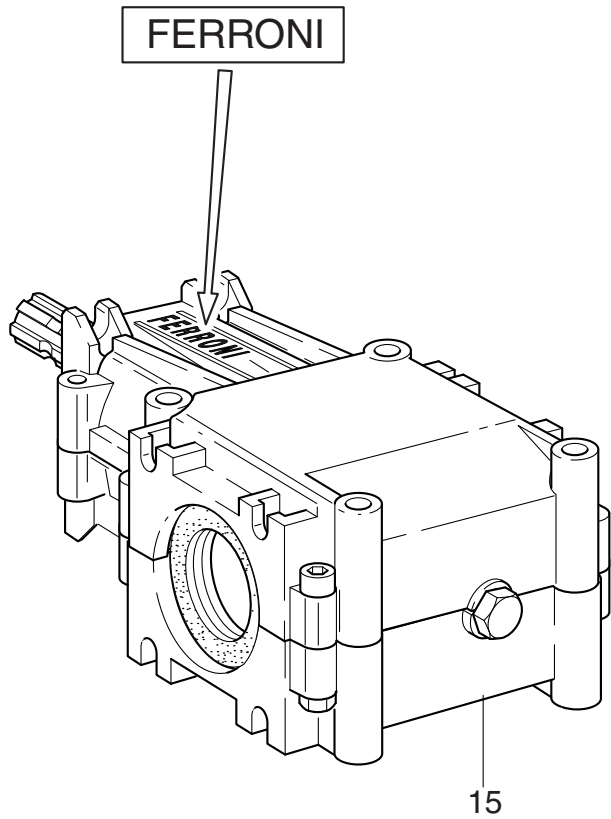

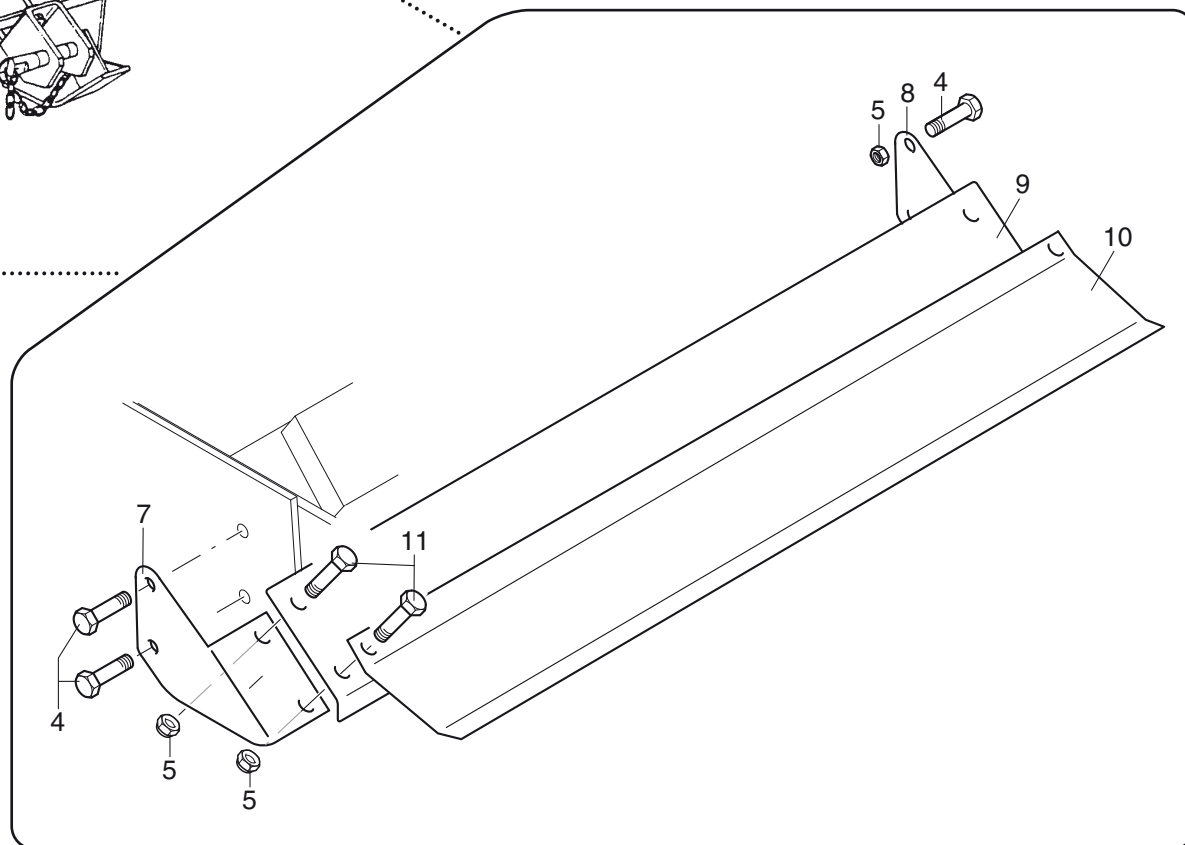
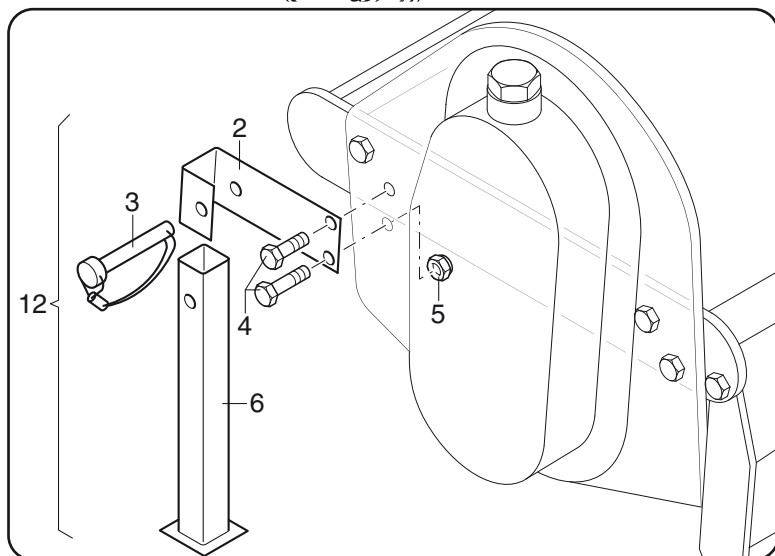
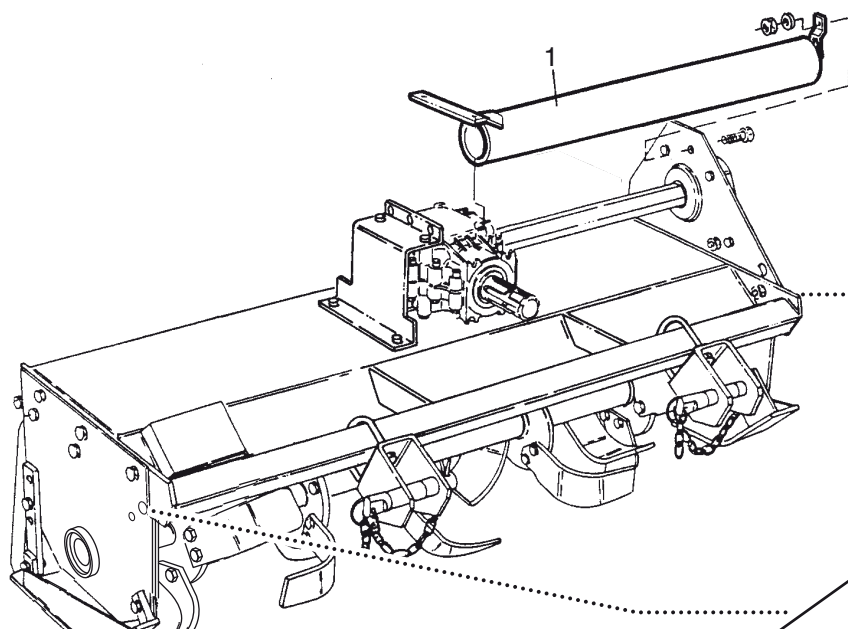

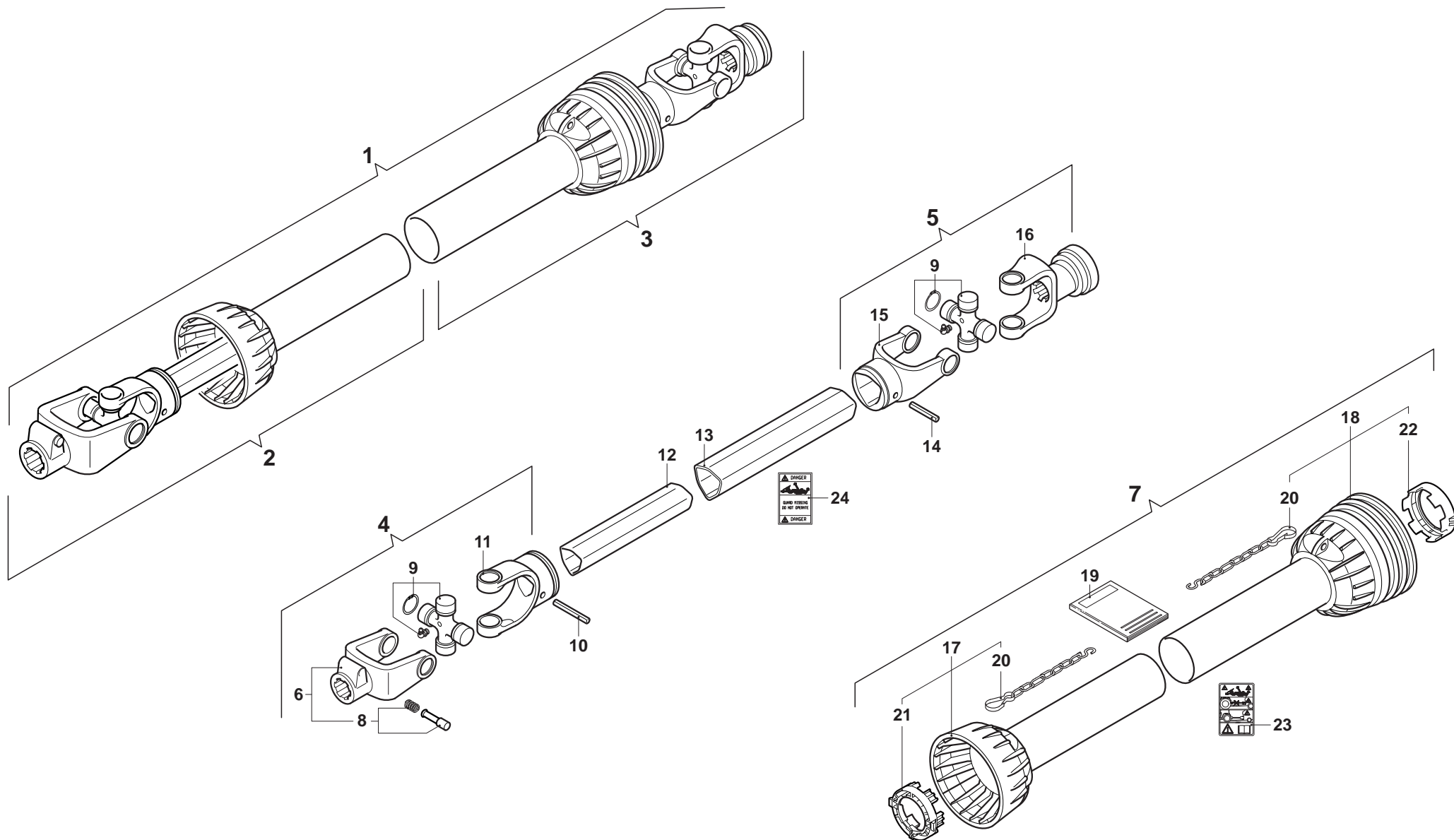

MURATORI MZ2S

TAV. 5.0

POS.	N° CODICE	Q	DESCRIZIONE	DESIGNATION	BENENNUNG	DESCRIPTION	DESIGNAZIONE	Da matr. De nr. serie Vom Seriennr. From serial nr.	Fino matr Jusqu'au nr. serie Bis Seriennr. Up to serial nr.
1	AE207SF	1	ALBERO CARDANICO COMPLETO	ARBRE A JOINTS DE CARDAN	KARDANWELLE	PTO SHAFT			
2	123.620.006.10	1	SEMIALBERO INTERNO	DEMI-ARBRE INTERIEUR	INNENHALBWELLE	INTERNAL HALF SHAFT			
3	123.520.059.10	1	SEMIALBERO ESTERNO	DEMI-ARBRE EXTERIEUR	AUSSENHALBWELLE	EXTERNAL HALF SHAFT			
4	121.022.714.10	1	SNODO	ARTICULATION	GELENK	ARTICULATION			
5	121.022.783.10	1	SNODO	ARTICULATION	GELENK	ARTICULATION			
6	141.022.001	1	FORCELLA	FOURCHE	GABEL	YOKE			
7	142.320.007.7250	1	PROTEZIONE	PROTECTION	SCHUTZ	GUARD			
8	166.026.004	1	PULSANTE	BOUTON	DRUCKKNOPF	PUSH BOTTON			
9	180.012.130	2	CROCIERA	CROISILLON	KREUZSTÜCK	SPIDER			
10	190.000.011	1	SPINA ELASTICA	GOUPILLE ELASTIQUE	SPANNSTIFT	ELASTIC PIN			
11	151.012.002	1	FORCELLA	FOURCHE	GABEL	YOKE			
12	153.120.107	1	TUBO INTERNO	TUBE INTERIEUR	INNENROHR	INTERNAL TUBE			
13	152.120.207.0730	1	TUBO ESTERNO	TUBE EXTERIEUR	AUSSENROHR	EXTERNAL TUBE			
14	190.000.012	1	SPINA ELASTICA	GOUPILLE ELASTIQUE	SPANNSTIFT	ELASTIC PIN			
15	151.012.003	1	FORCELLA	FOURCHE	GABEL	YOKE			
16	141.022.446	1	FORCELLA	FOURCHE	GABEL	YOKE			
17	142.327.007.7250	1	PROTEZIONE INTERNA	PROTECTION INTERIEURE	INNENSCHUTZ	INTERNAL GUARD			
18	142.326.007.7250	1	PROTEZIONE ESTERNA	PROTECTION EXTERIEURE	AUSSENSCHUTZ	EXTERNAL GUARD			
19	190.000.692	1	MANUALE ISTRUZIONI	MANUEL D'UTILISATION ET D'ENTRETIEN	BETRIEBS- UND WARTUNGSANLEITUNG	USE AND MAINTENANCE MANUAL			
20	180.016.636	2	CATENA	CHAINE	KETTE	CHAIN			
21	180.012.381	1	GHIERA	FRETTE	NUTMUTTER	RING NUT			
22	180.012.380	1	GHIERA	FRETTE	NUTMUTTER	RING NUT			
23	190.000.099	1	ETICHETTA	ETIQUETE	ETIKETT	LABEL			
24	190.000.098	1	ETICHETTA	ETIQUETE	ETIKETT	LABEL			

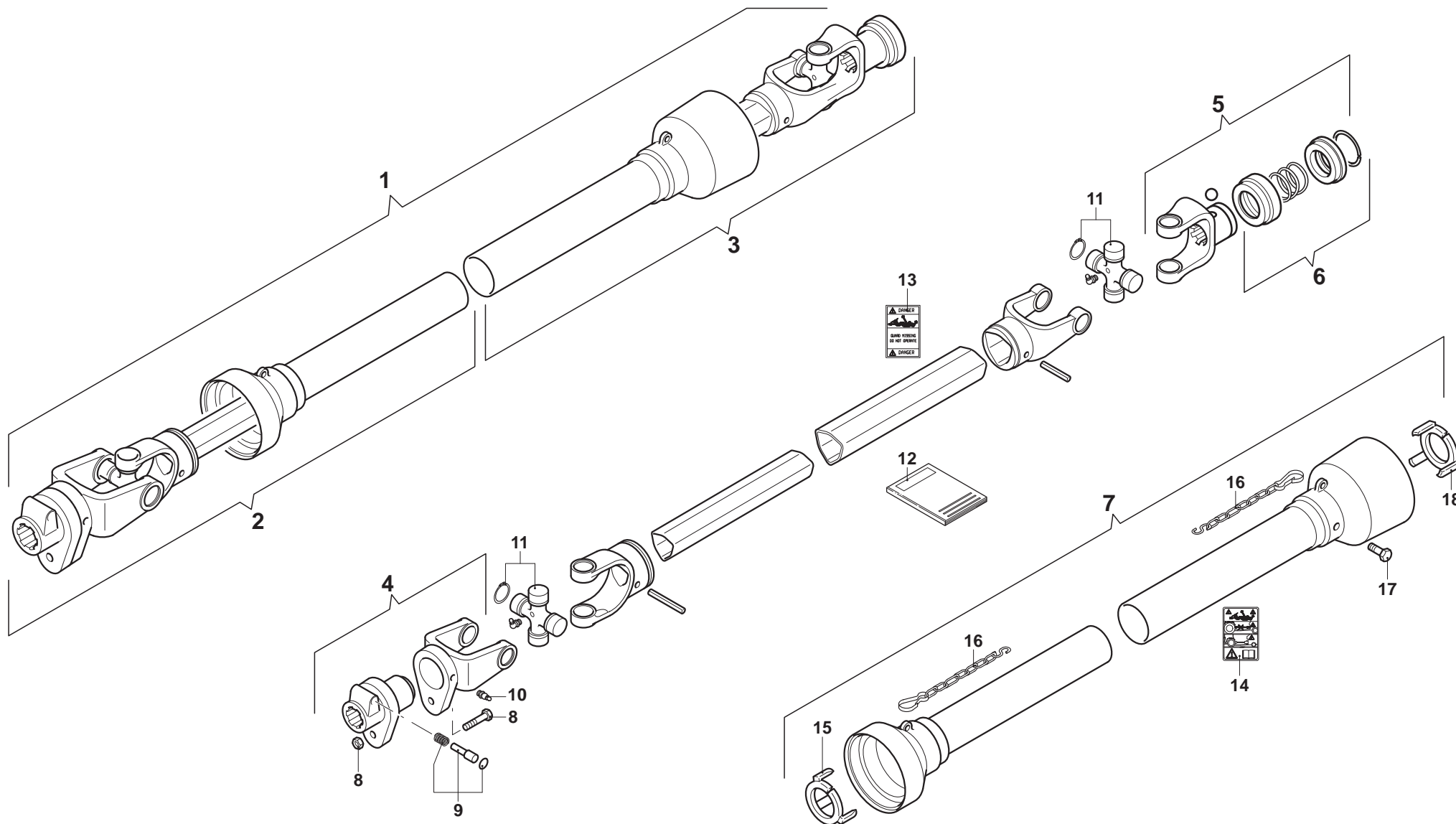

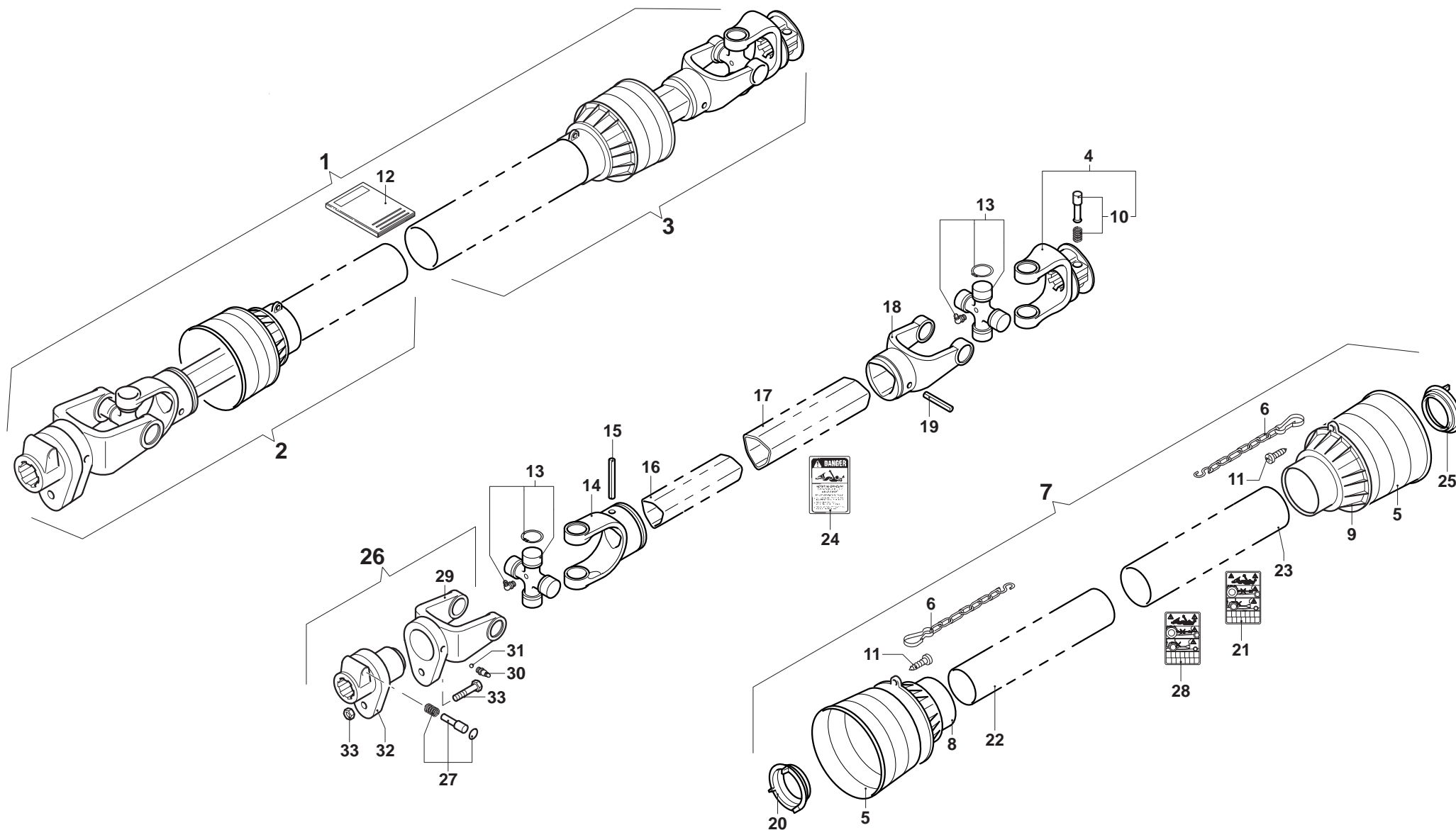

MURATORI MZ2S

TAV. 6.1

POS.	N° CODICE	Q	DESCRIZIONE	DESIGNATION	BENENNUNG	DESCRIPTION	DESIGNAZIONE	Da matr. De nr. serie Vom Seriennr. From serial nr.	Fino matr Jusqu'au nr. serie Bis Seriennr. Up to serial nr.
1	AB207FSBDO	1	ALBERO CARDANICO COMPLETO	ARBRE A JOINTS DE CARDAN	KARDANWELLE	PTO SHAFT		131570	
2	B2N051CE1098	1	SEMIALBERO INTERNO	DEMI-ARBRE INTERIEUR	INNENHALBWELLE	INTERNAL HALF SHAFT		131570	
3	B2N051CE2001	1	SEMIALBERO ESTERNO	DEMI-ARBRE EXTERIEUR	AUSSENHALBWELLE	EXTERNAL HALF SHAFT		131570	
4	0800203	1	FORCELLA	FOURCHE	GABEL	YOKE		131570	
5	021902C001	2	CUFFIA	CAPOUCHON	HAUBE	GUARD		131570	
6	0252000001	2	CATENA	CHAINE	KETTE	CHAIN		131570	
7	083CE02051	1	PROTEZIONE	PROTECTION	SCHUTZ	GUARD		131570	
8	025402C002	1	PROTEZIONE INTERNA	PROTECTION INTERIEURE	INNENSCHUTZ	INTERNAL GUARD		131570	
9	025402C001	1	PROTEZIONE ESTERNA	PROTECTION EXTERIEURE	AUSSENSCHUTZ	EXTERNAL GUARD		131570	
10	0986014042	1	PULSANTE	BOUTON	DRUCKKNOPF	PUSH BOTTON		131570	
11	0998052242	6	VITE	VIS	SCHRAUBE	SCREW		131570	
12	09872101	1	MANUALE ISTRUZIONI	MANUEL D'UTILISATION ET D'ENTRETIEN	BETRIEBS- UND WARTUNGSANLEITUNG	USE AND MAINTENANCE MANUAL		131570	
13	08202	2	CROCIERA	CROISILLON	KREUZSTÜCK	SPIDER		131570	
14	08002011	1	FORCELLA	FOURCHE	GABEL	YOKE		131570	
15	098700850	1	SPINA ELASTICA	GOUPILLE ELASTIQUE	SPANNSTIFT	ELASTIC PIN		131570	
16	09881294100	1	TUBO INTERNO	TUBE INTERIEUR	INNENROHR	INTERNAL TUBE		131570	
17	09881363100	1	TUBO ESTERNO	TUBE EXTERIEUR	AUSSENROHR	EXTERNAL TUBE		131570	
18	08002021	1	FORCELLA	FOURCHE	GABEL	YOKE		131570	
19	098700855	1	SPINA ELASTICA	GOUPILLE ELASTIQUE	SPANNSTIFT	ELASTIC PIN		131570	
20	025502C002	1	GHIERA	FRETTE	NUTMUTTER	RING NUT		131570	
21	09872010	1	ETICHETTA	ETIQUETE	ETIKETT	LABEL		131570	
22	0988955NB051	1	TUBO INTERNO	TUBE INTERIEUR	INNENROHR	INTERNAL TUBE		131570	
23	0988961NB051	1	TUBO ESTERNO	TUBE EXTERIEUR	AUSSENROHR	EXTERNAL TUBE		131570	
24	09872006	1	ETICHETTA	ETIQUETE	ETIKETT	LABEL		131570	

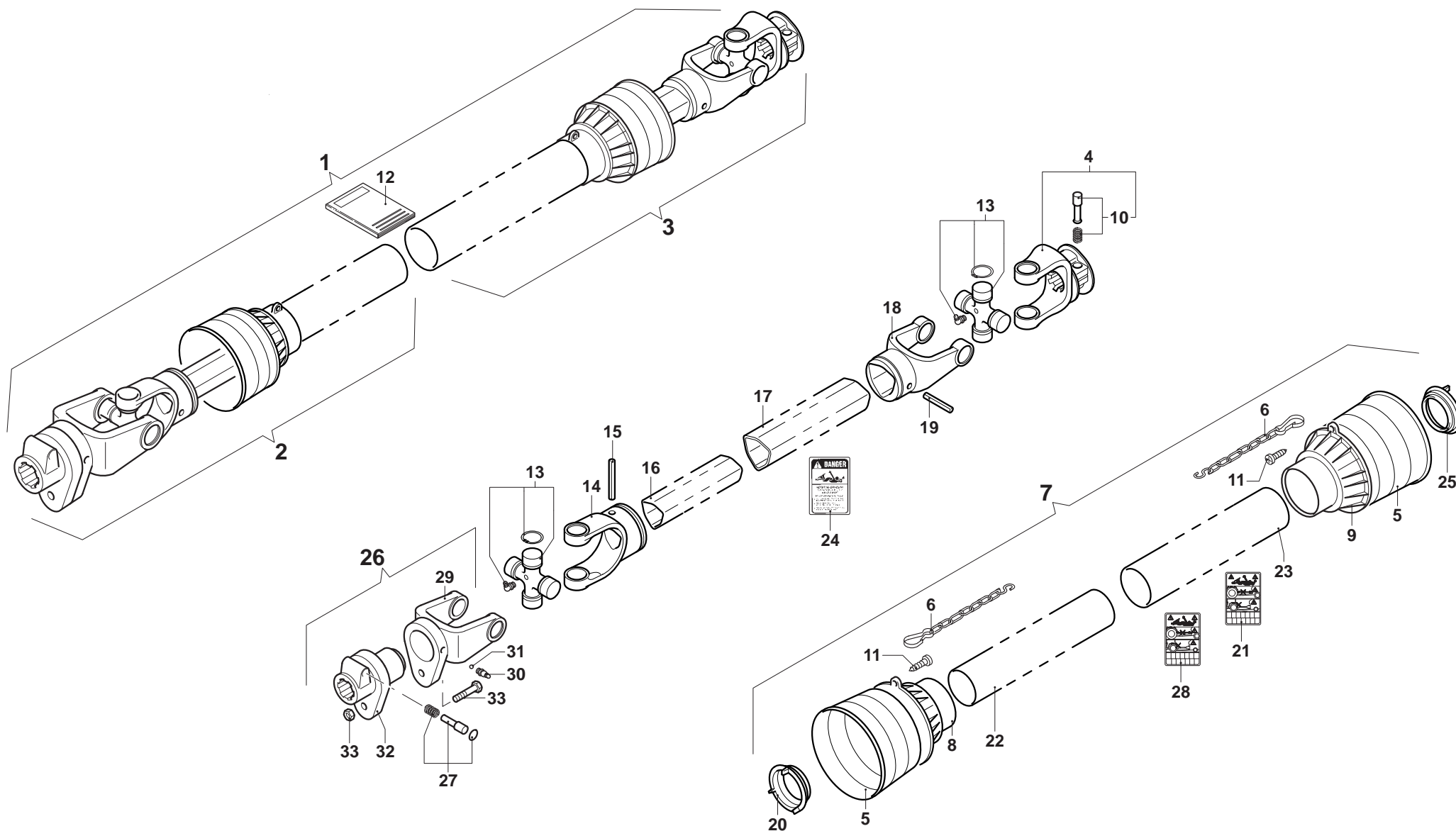

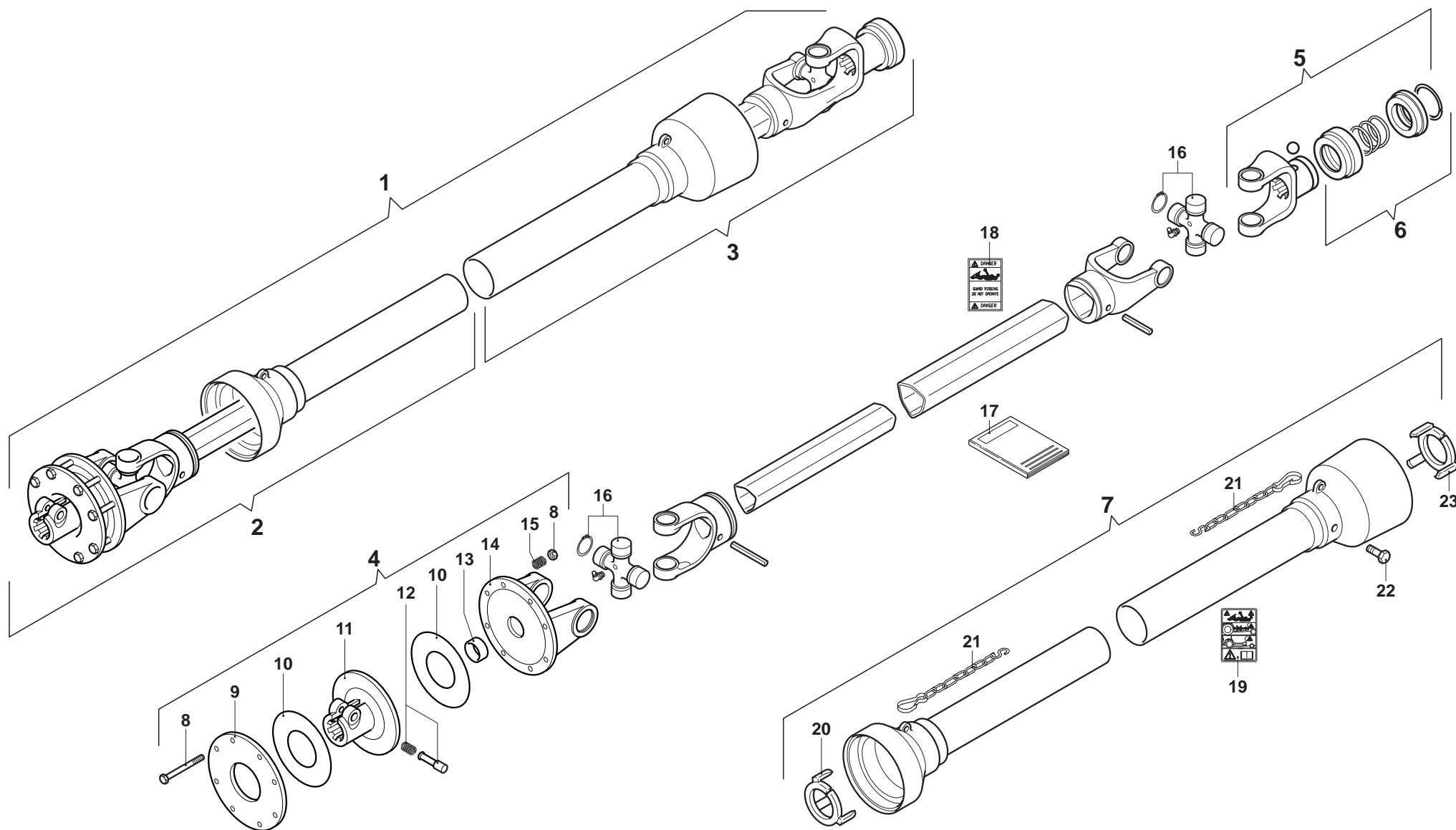

MURATORI MZ2S

TAV. 7.0

POS.	N° CODICE Q	DESCRIZIONE	DESIGNATION	BENENNUNG	DESCRIPTION	DESIGNAZIONE	Da matr.	Fino matr
							De nr. serie Vom Seriennr. From serial nr.	Jusqu'au nr. serie Bis Seriennr. Up to serial nr.
1	AE207FF138DO 1	ALBERO CARDANICO COMPLETO	ARBRE A JOINTS DE CARDAN	KARDANWELLE	PTO SHAFT			
2	8123.420.171.11 1	SEMIALBERO INTERNO	DEMI-ARBRE INTERIEUR	INNENHALBWELLE	INTERNAL HALF SHAFT			
3	8123.320.176.11 1	SEMIALBERO ESTERNO	DEMI-ARBRE EXTERIEUR	AUSSENHALBWELLE	EXTERNAL HALF SHAFT			
4	8146.221.004.1 1	FRIZIONE	EMBRYAGE	KUPPLUNG	CLUTCH			
5	141.022.324.1 1	FORCELLA	FOURCHE	GABEL	YOKE			
6	165.000.628 1	KIT COLLARE	KIT COLLIER	ROHRSCHELLESATZ	COLLAR KIT			
7	142.220.287.72311	PROTEZIONE	PROTECTION	SCHUTZ	GUARD			
8	165.000.501 8	BULLONE	BOULON	BOLZEN	BOLT			
9	180.014.020.1 1	DISCO	DISQUE	SCHEIBE	DISC			
10	180.014.019 2	DISCO	DISQUE	SCHEIBE	DISC			
11	151.014.018.1 1	MOZZO	MOYEU	NABE	HUB			
12	165.000.502 1	PULSANTE	BOUTON	DRUCKKNOPF	PUSH BOTTON			
13	180.015.020 1	ANELLO	BAGUE	RING	RING			
14	151.012.139.1 1	FORCELLA	FOURCHE	GABEL	YOKE			
15	180.014.022 8	MOLLA	RESSORT	FEDER	SPRING			
16	180.012.130 2	CROCIERA	CROISILLON	KREUZSTÜCK	SPIDER			
17	190.000.371 1	MANUALE ISTRUZIONI	MANUEL D'UTILISATION ET D'ENTRETIEN	BETRIEBS- UND WARTUNGSANLEITUNG	USE AND MAINTENANCE MANUAL			
18	190.000.098 1	ETICHETTA	ETIQUETE	ETIKETT	LABEL			
19	190.000.099 1	ETICHETTA	ETIQUETE	ETIKETT	LABEL			
20	8180.012.183 1	GHIERA	FRETTE	NUTMUTTER	RING NUT			
21	180.016.025 1	CATENA	CHAINE	KETTE	CHAIN			
22	8180.014.240 6	VITE	VIS	SCHRAUBE	SCREW			
23	8180.012.184 1	GHIERA	FRETTE	NUTMUTTER	RING NUT			

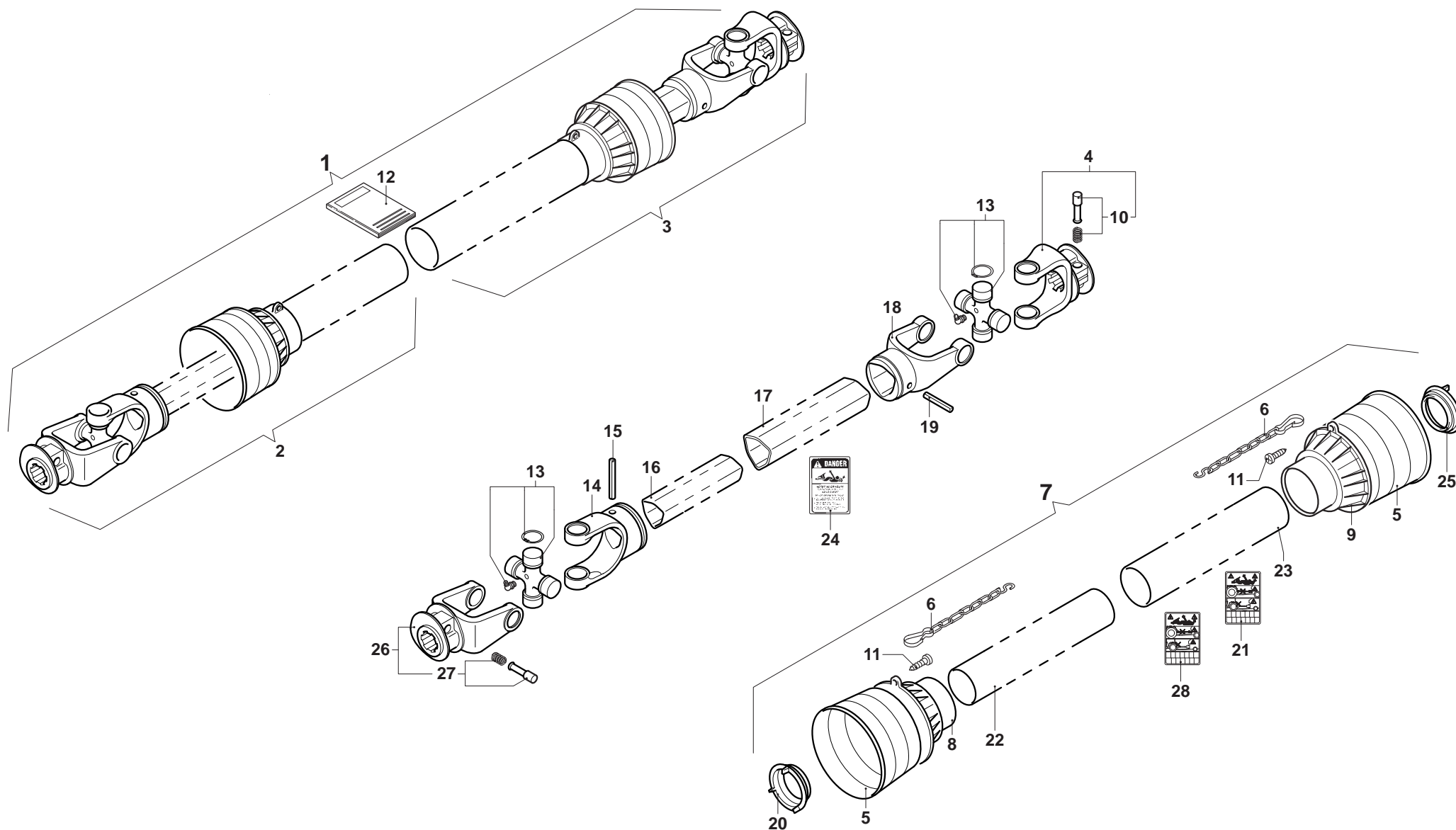

MURATORI MZ2S

TAV. 8.0

POS.	N° CODICE	Q	DESCRIZIONE	DESIGNATION	BENENNUNG	DESCRIPTION	DESIGNAZIONE	Da matr. De nr. serie Vom Seriennr. From serial nr.	Fino matr Jusqu'au nr. serie Bis Seriennr. Up to serial nr.
1	AB207SFDO	1	ALBERO CARDANICO COMPLETO	ARBRE A JOINTS DE CARDAN	KARDANWELLE	PTO SHAFT			
2	B2N061CE1001	1	SEMIALBERO INTERNO	DEMI-ARBRE INTERIEUR	INNENHALBWELLE	INTERNAL HALF SHAFT			
3	B2N051CE2001	1	SEMIALBERO ESTERNO	DEMI-ARBRE EXTERIEUR	AUSSENHALBWELLE	EXTERNAL HALF SHAFT			
4	0800203	1	FORCELLA	FOURCHE	GABEL	YOKE			
5	021902C001	2	CUFFIA	CAPOUCHON	HAUBE	GUARD			
6	0252000001	2	CATENA	CHAINE	KETTE	CHAIN			
7	083CE02051	1	PROTEZIONE	PROTECTION	SCHUTZ	GUARD			
8	025402C002	1	PROTEZIONE INTERNA	PROTECTION INTERIEURE	INNENSCHUTZ	INTERNAL GUARD			
9	025402C001	1	PROTEZIONE ESTERNA	PROTECTION EXTERIEURE	AUSSENSCHUTZ	EXTERNAL GUARD			
10	0986014047	1	PULSANTE	BOUTON	DRUCKKNOPF	PUSH BOTTON			
11	0998052242	6	VITE	VIS	SCHRAUBE	SCREW			
12	09872101	1	MANUALE ISTRUZIONI	MANUEL D'UTILISATION ET D'ENTRETIEN	BETRIEBS- UND WARTUNGSANLEITUNG	USE AND MAINTENANCE MANUAL			
13	08202	2	CROCIERA	CROISILLON	KREUZSTÜCK	SPIDER			
14	08002011	1	FORCELLA	FOURCHE	GABEL	YOKE			
15	098700850	1	SPINA ELASTICA	GOUPILLE ELASTIQUE	SPANNSTIFT	ELASTIC PIN			
16	09881294100	1	TUBO INTERNO	TUBE INTERIEUR	INNENROHR	INTERNAL TUBE			
17	09881363100	1	TUBO ESTERNO	TUBE EXTERIEUR	AUSSENROHR	EXTERNAL TUBE			
18	08002021	1	FORCELLA	FOURCHE	GABEL	YOKE			
19	098700855	1	SPINA ELASTICA	GOUPILLE ELASTIQUE	SPANNSTIFT	ELASTIC PIN			
20	025502C002	1	GHIERA	FRETTE	NUTMUTTER	RING NUT			
21	09872010	1	ETICHETTA	ETIQUETE	ETIKETT	LABEL			
22	0988955NB051	1	TUBO INTERNO	TUBE INTERIEUR	INNENROHR	INTERNAL TUBE			
23	0988961NB051	1	TUBO ESTERNO	TUBE EXTERIEUR	AUSSENROHR	EXTERNAL TUBE			
24	09872006	1	ETICHETTA	ETIQUETE	ETIKETT	LABEL			

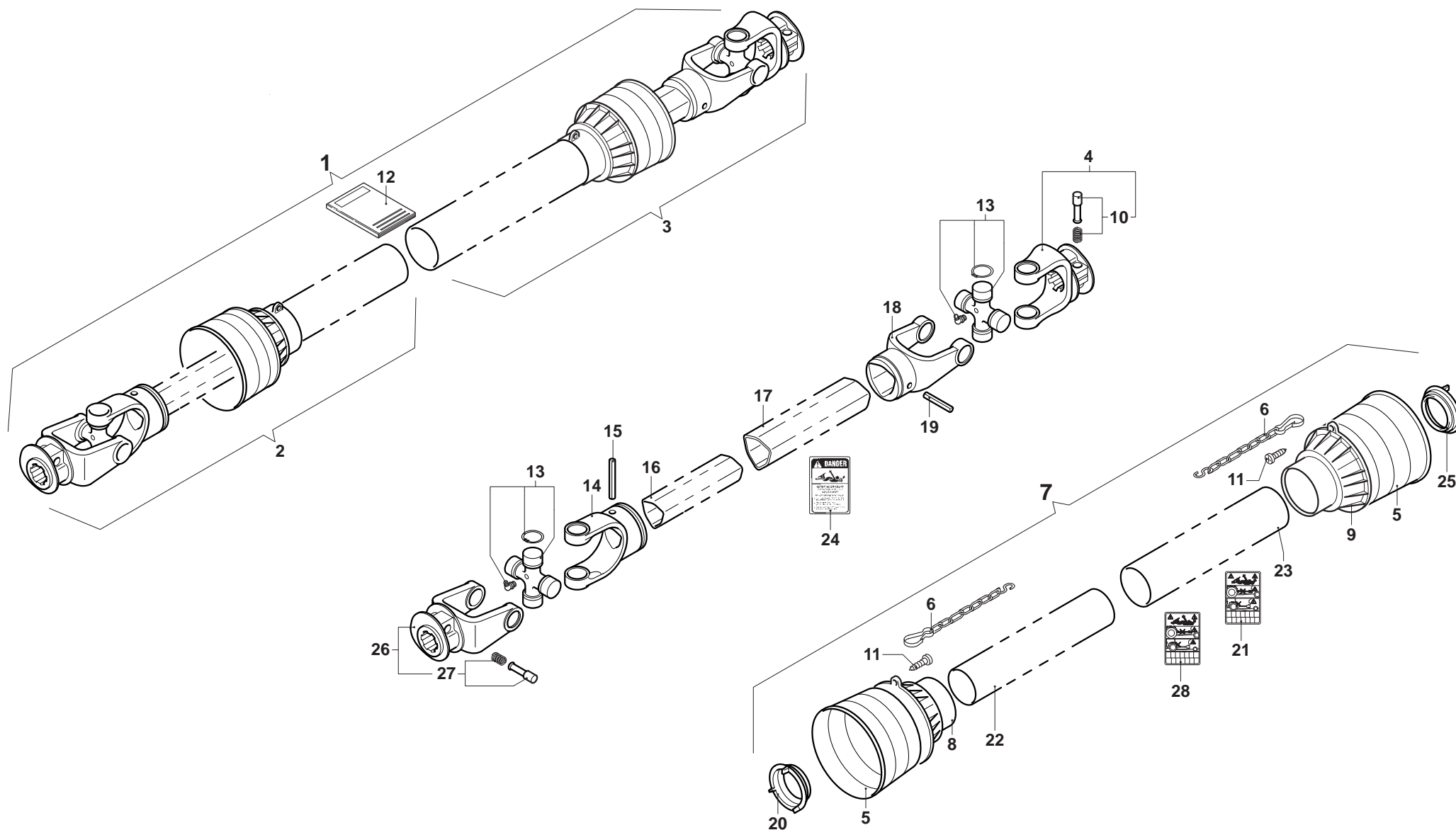



MURATORI S.p.A.

Via Pavarello, 21 - 41051 Castelnuovo Rangone (MO) Italy - Tel. 059.5330611 Fax 059.537259

www.muratoriequip.it *info@muratoriequip.it*

Capitale sociale Euro 480.000 interamente versato

Registro Imprese di Modena

Codice fiscale e numero d'iscrizione: 00708860366